

1

1 1 가 ;
 2 1 가 ;
 3 1 가 ;
 4 2 - ' ;
 5 2 2 - ' ;
 6 3 가 ;
 7 6 - ' ;
 8 5 ;
 9 6 ;
 10 9 가 ;
 11 7 ;
 12 8 가 ;
 13 9 ;
 14 13 가 ;
 15 10 가 ;
 16 15 ;
 17 가 ;
 18 가 .

- *
 1 : (burner body)
 2 : (burner cap)
 3 : 2 (secondary air supply path)
 7 : (flame slits)
 10 :
 13 : (ring)
 14 : (seal portion)
 16 : (hole)
 17 : (protrusion portion)
 18 : 가
 21 : (plane seal portion)
 23 : 2 가
 23a : 2
 23b : 2
 24 :
 25 :
 26 :
 28 :
 29 :
 30 :

17 가 가 가 (52) 가 (51) . 가

가

,가

,가

,가

가

가

가

가

가

가

가

,가

가

1가

2

2

가

2가

, 2

가

2

, 2

가

, 1

가

(

2

2가

가

가

1

가

/

2가

가

.가

.가

가

,가

2

, 2

, 2

(el

ectromotive force)

(1)

1

1

가

가

(circular head portion)(1a) 가

(gas

mixer tube)(1b)

(1a)

(1)

(1c)

가

가

가 (1)

(2)

(2)

(1a) 가

가 (1a)

(inner hollow chamber)(1d)가

(1a)

.가

(1b)

가 (1b)

(supply port)(1e)가

가

(1d)

가

(conically circular upper surface portion)(2a)

(4)

(2a)

(2a)

(4),

(5),

(6)

(5)

(2a)

(6)

(5)

(2)

(1a)

(2)

(6)가

(1c)

(6)

(1c)

(4)

(1c)

(1d)

가

가

(2)

(6)

(1c)

가

(4)

(1c)

가

가

2

(2)

(3)

, 3

2

가

5 가 (ring)(13) (13) (12) (13) (12)가 (13) (13) (1) (1c) (13) (1c) 가 (13) (13) (step portion)(15) (13) (13) (seal portion)(14) (1) (1c) (2M) 가 (1) (1c) 가 (5) 가 (2M) (14) (13) (1) (2M) (6) (9) (2N) 6 (caulking) 10 9 가 (13A) 6 가 1 5 가 가 9 10 (11A)가 (1) (1c) (1d) (16) (13A) (16) (17) (13A)가 (12) (16) (17)가 (17) (16) (13A) 6 가 (17) (16) (play)(18) (17) (16) (caulked). (2N) (13A) 가, (13A) (1) (1c) (1c) (13A) (13A) (14) (13A) (1) (1c) 가 (13A) (15) (2M) 가 (1) (1c) 가 () (14) (17) (1) (1c) 가 (14) (1) (18) (1c) () (17) (16) (17) (16) (17) (16) (17) (16) (7) (7) 가 1 6 가 가 11 7 (13B) (outer peripheral groove)(19) () (2P) 가 (13B) (19) (20) (2P) (13B) (21) (21) (13B) (19) (1) (1c) (21) (13B) (1d) 가 (21) (13) (22) 가 (1c) 가 () (2P) 가 (13B) 가 () (21) (21)가 (13B) (2P) (21)가 (13B) (2P) (8) (8) 가 1 7 가 가 12 8 가 (concentric structure) () (1) (12) (1) (2) 1 가 2 (23) (23) (23) (1b) (23a) 가 , 2 (23a) 1 (23a) 2 가 (second gas mixer tube)(23b)[가 (1b)]

2 (23) 2 (23a) 2 (23c) 2 (3) 2 (23c) 2 (2)

3a) 2 (23c) 2 (3) , 2 가

8 가 , 1 [(1) (2)] 2 (23)

(9) , 1 / 2 (23)

13 9 (24)가 , 14 13

9 가 1 8 가

13 14 (2Q) (opening portion)(2)

6) 가 (cylindrical portion)(25) (24) (24) (26)

9 가 (2a) 가 , (2Q) 가

9 가 (air supply holes)(27)가 (27)

(2Q) (1d) 2 (2Q) (24) 2 , 2

(10) (27) (26) , 16 15

15 16 , 가 (4) ((4b)) (concave groove)

(28) 가 (2R) (28) (7) (1) (4b)

(electromotive force) , (flame slit for ignition)(30) (side surface)(29)

(30) (32) , (burner safety device)(31)

(57)

1. 가 , 가 가 가 ;
2. 가 가 , 2 , 2 , 가 , 가 ,
3. 1 , 가 가 , 2

15 ,
가 ,
가 ,가

가 ,
가 ,가
가 ,가
가 .

24.
15 ,
2 ,

가 .

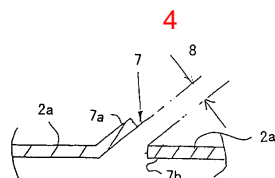
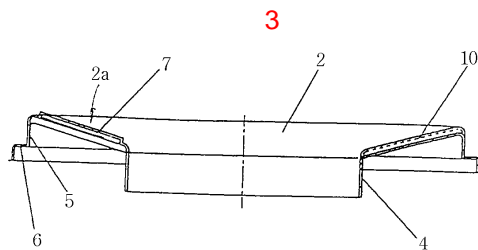
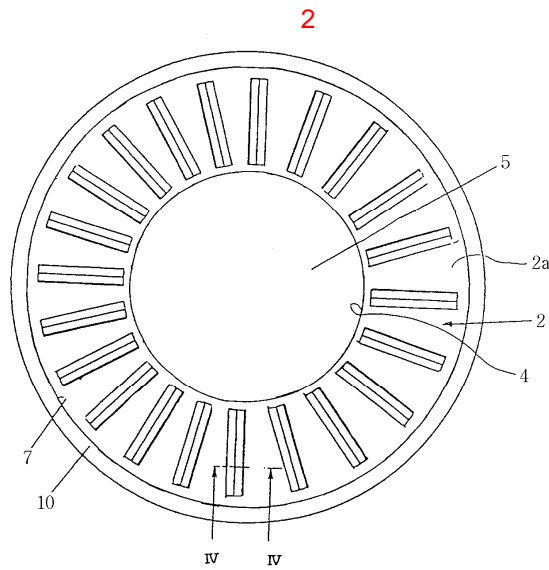
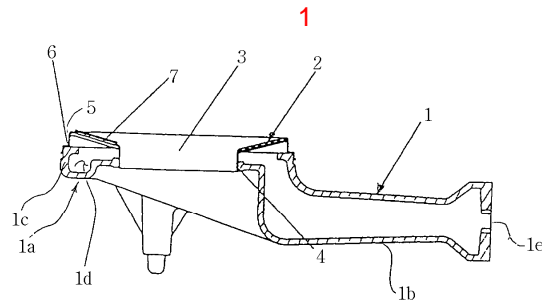

5

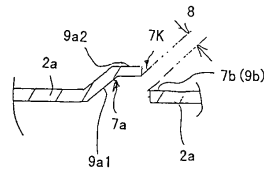

6

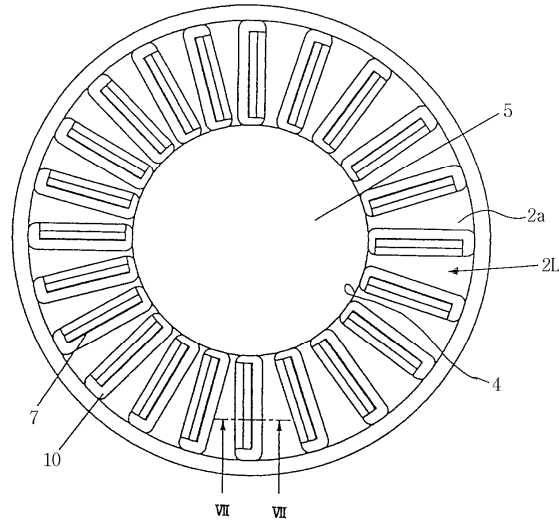

7

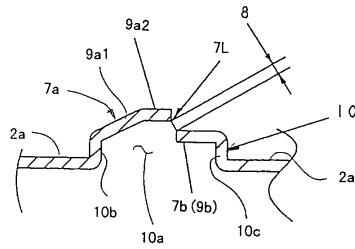

8

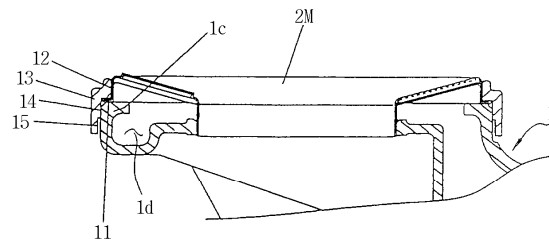

9

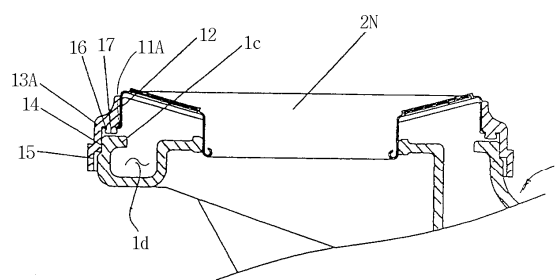

10

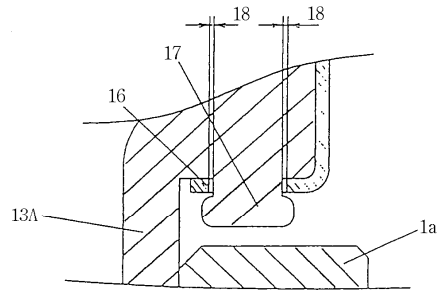

11

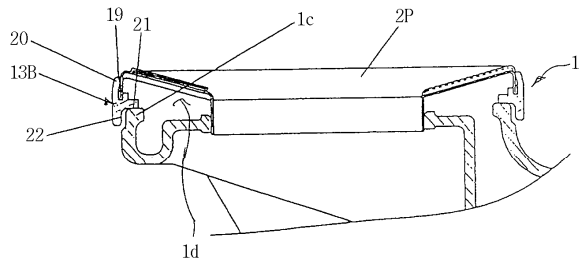

12

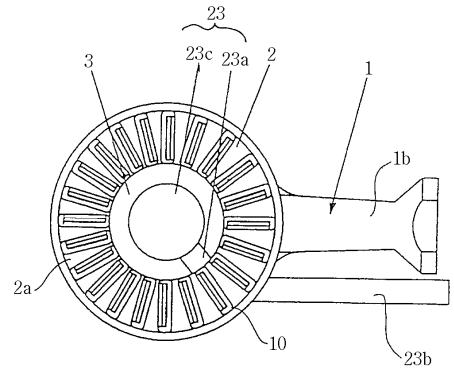

13

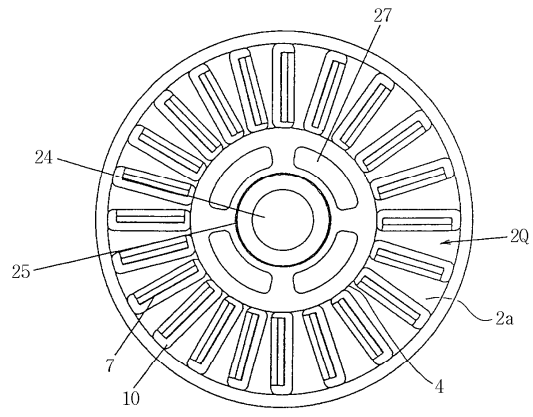

14

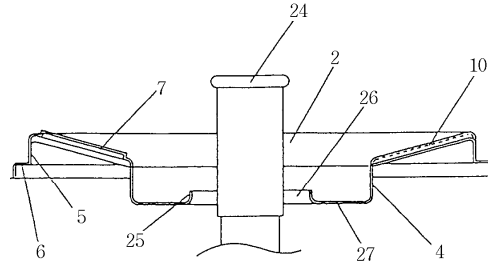

15

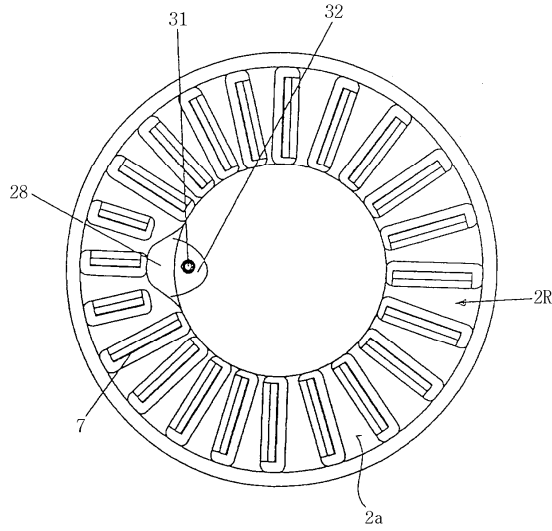

16

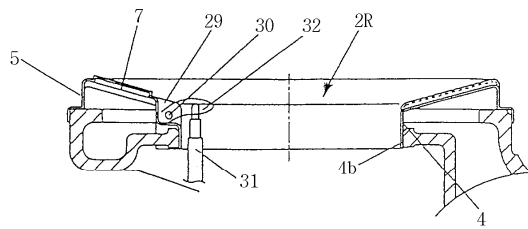

17

종래기술

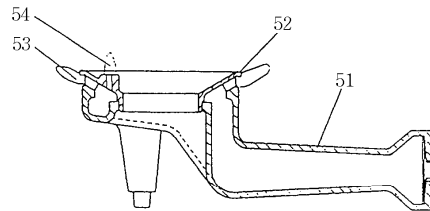

18

종래기술

