



INTERNATIONAL APPLICATION PUBLISHED UNDER THE PATENT COOPERATION TREATY (PCT)

(51) International Patent Classification ⁵ : H04R 25/00, A61F 11/04	A1	(11) International Publication Number: WO 94/17645 (43) International Publication Date: 4 August 1994 (04.08.94)
---	----	--

(21) International Application Number: PCT/US94/00853

(22) International Filing Date: 24 January 1994 (24.01.94)

(30) Priority Data:
08/008,663 25 January 1993 (25.01.93) US(71) Applicant: AUDITORY MICROMACHINES, INC. [US/US];
629 Oak Street, Suite 201, Cincinnati, OH 45206 (US).(72) Inventors: LESINSKI, S., George; 629 Oak Street, Suite 201,
Cincinnati, OH 45206 (US). HENDERSON, H., Thurman;
629 Oak Street, Suite 201, Cincinnati, OH 45206 (US).(74) Agents: EVANS, Richard, H. et al.; Wood, Herron & Evans,
2700 Carew Tower, Cincinnati, OH 45202 (US).(81) Designated States: AT, AU, BB, BG, BR, BY, CA, CH, CN,
CZ, DE, DK, ES, FI, GB, HU, JP, KP, KR, KZ, LK, LU,
LV, MG, MN, MW, NL, NO, NZ, PL, PT, RO, RU, SD,
SE, SK, UA, UZ, VN, European patent (AT, BE, CH, DE,
DK, ES, FR, GB, GR, IE, IT, LU, MC, NL, PT, SE), OAPI
patent (BF, BJ, CF, CG, CI, CM, GA, GN, ML, MR, NE,
SN, TD, TG).**Published***With international search report.**Before the expiration of the time limit for amending the
claims and to be republished in the event of the receipt of
amendments.*

(54) Title: IMPLANTABLE AUDITORY SYSTEM WITH MICROMACHINED MICROSENSOR AND MICROACTUATOR

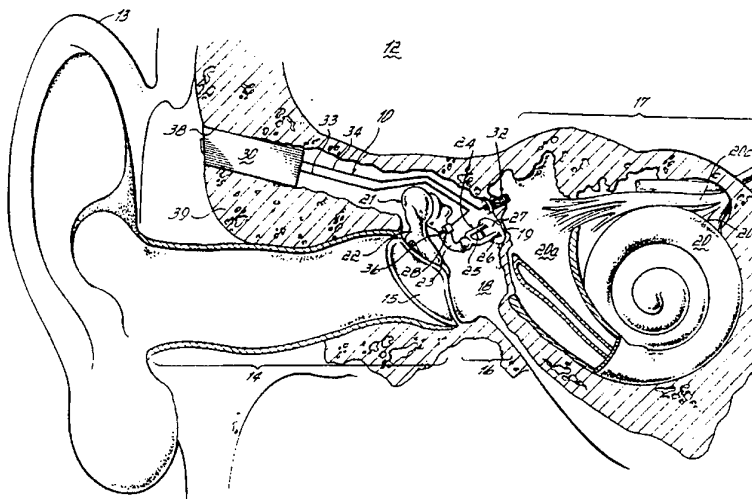

(57) Abstract

An implantable auditory system (10) for a human subject (12) includes a microsensor (28), a processor (30) and a microactuator (32). The microsensor (28) is implanted in the middle ear (16) to transduce sound waves into electrical signals. The processor (30) is implanted in a hole (38) surgically sculpted in the skull (39) and controls amplification and processing of the electrical signals. The microactuator (32) is micromachined from a single crystal (80) and acts as a parallel plate capacitor, with a diaphragm (88) spaced from the rest of the crystal (80) by an extremely small void (90) therebetween. The microactuator (32) is implanted in the middle ear (16), and it may extend into the inner ear (17) through a surgically formed fenestration (83) or be mounted to the ossicular chain (21). Electrical signals conveyed to the microactuator (32) set up electric fields across the narrow void (90) and the diaphragm (88) to produce electrostatic forces that cause the diaphragm (88) to vibrate, thereby directly or indirectly vibrating fluid (20a) in the inner ear (17). Use of electrostatic forces to vibrate inner ear fluid (20a) reduces electrical current requirements, resulting in increased battery (44) life.

FOR THE PURPOSES OF INFORMATION ONLY

Codes used to identify States party to the PCT on the front pages of pamphlets publishing international applications under the PCT.

AT	Austria	GB	United Kingdom	MR	Mauritania
AU	Australia	GE	Georgia	MW	Malawi
BB	Barbados	GN	Guinea	NE	Niger
BE	Belgium	GR	Greece	NL	Netherlands
BF	Burkina Faso	HU	Hungary	NO	Norway
BG	Bulgaria	IE	Ireland	NZ	New Zealand
BJ	Benin	IT	Italy	PL	Poland
BR	Brazil	JP	Japan	PT	Portugal
BY	Belarus	KE	Kenya	RO	Romania
CA	Canada	KG	Kyrgystan	RU	Russian Federation
CF	Central African Republic	KP	Democratic People's Republic of Korea	SD	Sudan
CG	Congo	KR	Republic of Korea	SE	Sweden
CH	Switzerland	KZ	Kazakhstan	SI	Slovenia
CI	Côte d'Ivoire	LI	Liechtenstein	SK	Slovakia
CM	Cameroon	LK	Sri Lanka	SN	Senegal
CN	China	LU	Luxembourg	TD	Chad
CS	Czechoslovakia	LV	Latvia	TG	Togo
CZ	Czech Republic	MC	Monaco	TJ	Tajikistan
DE	Germany	MD	Republic of Moldova	TT	Trinidad and Tobago
DK	Denmark	MG	Madagascar	UA	Ukraine
ES	Spain	ML	Mali	US	United States of America
FI	Finland	MN	Mongolia	UZ	Uzbekistan
FR	France			VN	Viet Nam
GA	Gabon				

- 1 -

**IMPLANTABLE AUDITORY SYSTEM
WITH MICROMACHINED MICROSENSOR
AND MICROACTUATOR**

Field of the Invention

This invention relates to an implantable auditory system for improving the hearing capability of a human subject with conductive and/or sensorineural hearing deficiency.

Background of the Invention

In normal human hearing, acoustical energy in the form of sound waves is directed into the ear canal of a human by the outer ear. The sound waves impinge upon a tympanic membrane, i.e. the eardrum, located at the inner end of the outer ear canal. The pressure of the sound waves causes tympanic vibrations in the eardrum, thereby producing mechanical energy.

Three interconnected bones referred to as the ossicular chain transfer these tympanic vibrations of the eardrum across the middle ear and into the inner ear. The ossicular chain includes three major bones, the malleus, the incus and the stapes. The stapes terminates at a membrane referred to as the oval window, which serves as the outer boundary for the inner ear.

- 2 -

Mechanical vibrations conducted to the oval window generate fluidic motion within the inner ear. A spiral shaped portion of the inner ear, referred to as the cochlea, includes auditory receptor cells connected to the ends of auditory nerve fibers. Fluid vibrations within the inner ear actuate the receptor cells, thereby causing the nerve fibers to transmit signals to the brain which are perceived by the subject as sound.

Generally, hearing difficulties fall into one of two categories. Conductive hearing loss relates to the inability, or inefficiency, in mechanically conveying the vibrations caused by sound waves through the outer ear, the middle ear and the oval window to the fluid of the inner ear. Sensorineural hearing impairment relates to deterioration of the receptor cells and/or nerve fibers within the inner ear, so that fluidic vibrations within the inner ear are not sensed at all, or are sensed at a lower magnitude.

Over the years, various devices or aids have been developed to improve the hearing of hearing impaired individuals. One such device is generally referred to as an externally worn hearing aid. This device amplifies processed sound waves in the external ear canal. While it has been estimated that 20% of hearing-impaired individuals have purchased a hearing aid, it is also reported that less than one-half of these individuals wear their hearing aids regularly.

- 3 -

Externally worn hearing aids suffer from several inherent problems which result in distorted hearing and a poorly tolerated device. First, the amplifying of sound waves in the external ear canal while the external canal is obstructed with a hearing aid produces constructive and destructive acoustical wave interference. This interference results in resonance of some frequencies, cancellation of other frequencies and distortion of the remaining acoustical waves.

Second, because of the relative proximity of the hearing aid microphone and speaker, acoustical feedback is a constant problem, producing "whistling and screeching" of the hearing aid when amplification is turned up. The more amplification required, the worse this problem becomes. While some hearing aids employ a tight-fitting mold to reduce this feedback, such a mold is usually uncomfortable, and often ulcerates the skin of the ear canal or produces autophony, i.e. the hearing by a patient of his or her own voice in that ear. Moreover, radiation of acoustical output back into the microphone via the hearing aid case or the hearing aid internal components further limits the gain/output of an externally worn hearing aid.

Third, these hearing aids provide only limited amplification, due primarily to the limited power from a hearing aid battery. Commercially available in-the-ear and behind-the-ear hearing aids amplify sound by a magnitude of about 30-70 dB.

- 4 -

Fourth, distortion of hearing aids is high. Compared with radios, stereo sets and other electronic devices, the electronic distortion of hearing aids is enormous. Average commercially available hearing aids have a total harmonic distortion of 2-25%. Transient and intermodulation distortion produce further acoustical problems. The signal-to-noise ratio of commercially available hearing aids is vastly inferior to even inexpensive sound systems.

Because of this acoustical and electronic distortion, signal processing is usually required in the form of band pass filters, noise suppression circuits, etc. These electronic circuits further drain the power source and limit amplification.

Fifth, externally worn hearing aids cannot be safely worn by a significant number of individuals whose hearing is impaired by diseases which affect the external ear canal or middle ear, such as congenital aural atresia with absent ear canal, external otitis, chronic otitis media, mastoiditis, eardrum preformation, etc.

Sixth, externally worn hearing aids cannot be effectively worn when playing contact sports, perspiring excessively, swimming, showering, working in excessive noise and in many other conditions.

Finally, externally worn hearing aids often carry a social stigma, particularly in children. This social distinction can adversely affect a child's positive self esteem.

- 5 -

As a result of these problems, a number of semi-implantable hearing devices have been developed. These hearing devices actuate the inner ear either electromagnetically or by a piezoelectric bimorph lever. However, after nearly thirty years of attempts to develop a practical electromagnetically or piezoelectrically actuated hearing aid, to applicant's knowledge, none of these devices have yet been approved in the United States by the FDA. This lack of success is the result of problems inherent in each of these approaches, problems which have not yet been solved.

Electromagnetic actuation devices have been unsuccessful for several reasons. First, the strength of the magnetic field which actuates the ear is directly dependent on the amount of current flowing through the magnetic coil and the number of turns in the coil. Thus, high current and/or a coil with an extremely large number of turns is required. For a conventionally sized coil, this high current requirement rapidly drains battery power, exhausting a conventionally sized battery source within several hours.

Second, the amount of amplification produced in the core magnet is approximately inversely proportional to the square of the distance between the induction coil and the core magnet. Third, these electromagnetic actuation devices may be susceptible to stray magnetic fields. Finally, in clinical trials in the United States, optimum amplification of electromagnetic

- 6 -

actuation devices has been in the range of only about 30-40dB.

The inherent flaw with piezoelectric bimorph lever relates to size. More specifically, a lever of
5 unrealistic length is necessary to attain adequate amplitude of sound vibrations to stimulate the middle ear ossicles. The middle ear is simply too small to accommodate the necessary piezoelectric lever length.

Presently, in Japan, surgeons are attempting to
10 inertially anchor a piezoelectric bimorph lever in the mastoid. However, these procedures require major destructive otologic surgery, including radical mastoidectomy and closure of the ear canal. To the extent that the implanting of such devices requires
15 destructive procedures, these devices are not likely to be approved in the United States by the Food and Drug Administration.

Perhaps more importantly, to the extent that implantable devices or procedures of this type do not
20 result in improved hearing, the situation is irreversible, and the subject will most likely have lost any opportunity for hearing improvement by other implantable devices or surgical procedures.

It is an objective of this invention to
25 overcome the present problems associated with commercially available, externally worn hearing aids via an auditory system which is sufficiently safe and reliable to achieve F.D.A. approval.

- 7 -

It is another objective of the invention to develop an implantable auditory system, and particularly an actuation device, with reduced electrical power requirements, better acoustical amplification, and which is small enough to eliminate the need for major and/or destructive surgical procedures.

It is still another object of the invention to develop an implantable auditory system with a high probability of success in overcoming a subject's conductive and/or sensorineural hearing deficiency, but which does not cause irreversible hearing loss in the subject if the system should wear out or prove to be unsuccessful.

The above-stated objectives are achieved by an implantable auditory system which comprises a micromachined microsensor and a micromachined microactuator which are very small, yet which provide up to 100dB of amplification. Because of the small size, surgical implanting of these components within the middle ear of a subject requires no destructive and/or irreversible surgical procedures.

To the contrary, present surgical techniques, including laser surgery, may be used to implant these micromachined components. In fact, according to one embodiment of the invention, the micromachined actuator employed by this auditory system may be incorporated into the bottom of a piston-like prostheses which is extended

- 8 -

through the stapes footplate in present stapedotomy techniques.

The auditory system of this invention is an integrated, fully implantable micro system which improves hearing in patients with conductive and/or sensorineural deafness. This auditory system utilizes silicon semiconductor microfabrication and micromachining techniques to produce integrated components which amplify hearing by electrostatically stimulating the fluid of the inner ear. Because of the size and configuration of the micromachined components, particularly the microactuator, which acts as a parallel plate capacitor, small voltage changes produce large electric fields which are used to vibrate the fluid of the inner ear.

According to the invention, the major components of this auditory system include a microsensor and a microactuator implanted in the middle ear of the subject and a signal processor, amplifier, and power source implanted subcutaneously in the cortical mastoid bone.

The microsensor is either a micromachined piezoresistive vibration sensor, a micromachined parallel plate capacitor, or a micromachined acoustical microphone designed and produced using microfabrication techniques and having a mass of less than about 30 grams. The microsensor senses acoustical pressure waves produced in the middle ear by mechanical vibrations of the eardrum or mechanical vibrations of one of the bones of the

- 9 -

ossicular chain, and it converts the sensed waves or vibrations into electrical signals. The microsensor may be secured to one of the bones of the ossicular chain, preferably the incus. Alternatively, particularly for
5 those individual subjects who suffer from congenital aural atresia, wherein the external canal is absent, the microsensor may be planted subcutaneously in the mastoid cortical bone behind the ear. If desired, the microsensor may be combined as an integral piece with the
10 micromachined microactuator. As yet another alternative, the sensor may be inserted into the incudostapedial joint, i.e. the joint between the incus and the stapes, and used to sense the pressure therebetween.

15 After the microsensor converts sensed mechanical vibrations into electrical signals, the electric signals pass from the microsensor through the facial recess to a signal processor, which includes a signal conditioner, an amplifier, and a power source.
20 The conditioned and amplified signal is then transmitted back to the microactuator located in the middle ear, which includes a flexible dielectric or semiconductive diaphragm on a semiconductor substrate that transduces the electrical signals back into mechanical vibrations to
25 directly stimulate the perilymph fluid of the cochlea through a fenestration in the promontory or the stapes footplate. Alternatively, the diaphragm of the microactuator mounts to a piston which resides in contact

- 10 -

with the incus or the stapes so that vibrations of the diaphragm and piston amplify the vibrations of the incus or the stapes, respectively, thereby indirectly stimulating the perilymph fluid. This latter alternative avoids the necessity of surgically entering the inner ear. This implanted auditory microsystem does not rely on amplification of sound waves in the external ear canal, and thus eliminates the substantial acoustical and electronic distortion created by present day externally worn hearing aids.

The microactuator is preferably a micromachined parallel plate capacitor with a major portion of a semiconductor crystal serving as one stationary plate and a flexible monolithic dielectric or semiconductive diaphragm spaced about 1-5 microns away from the major portion, with the spacing or void therebetween formed by etching. A metallized coating deposited on the exterior surface of the diaphragm may serve as the other "plate". Alternatively, if mounted in a fenestration in the promontory or stapes footplate and in contact with the perilymph, which is inherently electrically conductive, the perilymph may serve as the other "plate". The crystal may be doped. The doping of the crystal will dictate the etchants to be used in micromachining this capacitor.

Because of the extremely small thickness of the diaphragm and the void, voltage changes conveyed to the microactuator produce extremely high electric fields

- 11 -

across the "plates" of the micromachined capacitor. The resultant electrostatic forces acting upon the plates cause the diaphragm to flex. By locating the microactuator in a position where the diaphragm movements can vibrate the fluid of the inner ear, voltage changes conveyed to the micromachined microactuator actuate the auditory receptor cells to cause the associated nerve fibers to signal the brain to perceive sound.

According to one approach, the flexible diaphragm is a dielectric which resides in direct contact with the perilymph fluid of the inner ear. According to this approach, the microactuator is housed within a screw which is threaded through a promontory fenestration formed via laser or other surgery techniques. The diaphragm is located at the end of the screw. The external surface of the screw serves as one electrode, and contact between the inserted end of the screw and the ionic perilymph fluid causes the perilymph fluid to act as one conductive plate which resides in direct contact with the flexible dielectric diaphragm.

An electrical lead extended through the screw conveys electrical voltage signals to the stationary plate of the microactuator, i.e., the major portion of the semiconductor crystal, which is spaced from the flexible diaphragm. When using this approach, it is important to electrically insulate the doped semiconductor material, which serves as the stationary plate of the microactuator, from the electrically

- 12 -

conductive portions of the screw. This may be accomplished via a glass coating on the inside of the metal screw, or the use of a teflon screw coated on its external surface with an electrically conductive and biocompatible material such as gold.

This approach may also be used with a piston, rather than a screw, and by forming the fenestration in the stapes footplate, as in present stapedotomy techniques. In this present stapedotomy technique, passive sound transmission to the inner ear is achieved via mechanical vibration of a prosthesis surgically extending through the fenestration in the footplate. One embodiment of the present invention modifies this prosthesis by housing a micromachined capacitor in a piston extending into a fenestration in the footplate. Electronic actuation of the capacitor vibrates the diaphragm to amplify the vibrations of the piston. In this approach, if the electronics should happen to fail, the subject is no worse off because the mechanical piston, similar to presently used prostheses, is still in place.

Alternatively, the microactuator may be located in a micromachined semiconductor housing which is tapered to fit within a tapered fenestration in the promontory. In this approach, the flexible diaphragm may carry a conductive coating to serve as one of the plates, but preferably this perilymph is again used as the outer plate.

- 13 -

As another alternative, which is most applicable to a fenestration formed in the promontory, the diameter of the diaphragm may be increased and/or the diameter of the fenestration may be reduced by connecting
5 the flexible diaphragm to a piston and locating the diaphragm outside of the inner ear and the piston inside the inner ear.

As yet another approach, the microactuator may be mounted to the incus or the stapes, and inertially
10 grounded to the promontory if desired, so that movement of the flexible semiconductive diaphragm amplifies movement of the ossicular chain and thereby indirectly vibrates the perilymph fluid of the inner ear.

This inventive auditory system is made possible
15 only because of the small geometries attainable with the revolutionary "micromachining" processes which may be applied to single crystalline <100> oriented semiconductor silicon. With a microactuator formed by micromachining and having dimensions and geometries that
20 are this small, i.e. in the micrometer range, a relatively small voltage of a few volts can produce an enormous electrical field intensity which is entirely contained within the microactuator. As a result, strong electrostatic forces are generated which achieve a high
25 degree of acoustical actuation in the very small spaces available in the middle ear and inner ear of a subject. Moreover, because this acoustical actuation is achieved via electrostatic forces produced by a micromachined

capacitor, which uses only minimum electrical current, battery life for this auditory system is much longer than prior implantable systems. Preliminary studies indicate that an implanted five or six volt battery used to electrically drive the components of this auditory system can last up to four to five years.

Moreover, unlike implanted devices which rely upon electromagnetic actuation, stray magnetic fields can be expected to have virtually no effect on this auditory system. Likewise, stray electrical fields will have absolutely no effect on this system because the intensity of such stray electric fields will be several orders of magnitude lower than the intensity of the electric field produced in the electric fields generated in the microactuator used in this auditory system.

These and other features of the invention will be more readily understood in view of the following detailed description and the drawings.

Brief Description of the Drawings

Fig. 1 is a schematic sectional view through a portion of the skull of a human subject adjacent the ear and showing the relative positions of the components of an implantable auditory system constructed in accordance with the invention.

Fig. 1A is a schematic side view of the subject depicted in Fig. 1.

Fig. 2 is a block diagram which schematically depicts the electrical components of an auditory system constructed in accordance with the invention.

5 Fig. 3 is a cross-sectional schematic which depicts a first preferred embodiment of a microsensor used in an auditory system constructed in accordance with the invention.

Fig. 3A is a top schematic view of the microsensor of Fig. 3.

10 Fig. 4 is a cross-sectional schematic which depicts a second preferred embodiment of a microsensor used in an auditory system constructed in accordance with the invention.

Fig. 4A is a top elevational view of Fig. 4.

15 Fig. 5 is an enlarged schematic perspective view which depicts securement to the incus of a microsensor used in an auditory system constructed in accordance with the invention.

20 Fig. 6 is a cross-sectional schematic view which depicts a first preferred embodiment of a microactuator for vibrating fluid in the inner ear in accordance with the invention.

Fig. 7 is a cross-sectional schematic view of the actuator taken along lines 7-7 of Fig. 6.

25 Fig. 8 is a cross-sectional schematic which depicts a second preferred embodiment of a microactuator for vibrating fluid in the inner ear in accordance with the invention.

- 16 -

Fig. 8A is a bottom view of Fig. 8.

Fig. 9 is a cross-sectional schematic which depicts a third preferred embodiment of a microactuator for directly vibrating the fluid of the inner ear in accordance with the invention.

Fig. 9A is a cross-sectional schematic which depicts a variation of the embodiment of the microactuator shown in Fig. 9.

Fig. 10 is schematic perspective which depicts a fourth preferred embodiment of the microactuator for directly vibrating the fluid of the inner ear, wherein the microactuator connects to the incus and the stapes bones of the subject.

Fig. 11 depicts a fifth preferred embodiment of the invention wherein a microactuator indirectly vibrates the fluid of the inner ear through the stapes footplate but is not inertially grounded to the promontory of the subject.

Fig. 12 depicts a variation of the fifth embodiment of the invention shown in Fig. 11, wherein a microactuator for indirectly vibrating the fluid of the inner ear is inertially grounded to the promontory of the subject so as to contact the stapes footplate.

Fig. 13 depicts still another variation of the embodiment shown in Fig. 11 and 12, wherein the microactuator which indirectly vibrates the fluid of the inner ear is mounted to the incus, and the microactuator

- 17 -

is also inertially grounded to the promontory of the subject.

Fig. 14 is a cross sectional view of a microactuator in accordance with another embodiment of the invention.

Detailed Description of the Drawings

I. The General System

Fig. 1 shows the relative locations of the components of an implantable auditory system 10 constructed in accordance with this invention and implanted in the body of a human subject 12. Fig. 1 shows an external ear 13 of the subject 12 located at the outer end of the outer ear 14. The outer ear 14 terminates at the ear drum 15. The ear drum 15 is a tympanic membrane which mechanically vibrates in response to sound waves that travel through the outer ear 14. The ear drum 15 serves as a barrier between the outer ear 14 and the middle ear 16. The inner ear 17 is located inside the middle ear 16. A relatively large bone referred to as the promontory 18 separates the inner ear 17 from the middle ear 16. The promontory 18 includes an oval shaped window 19. The inner ear 17 includes a shell-shaped organ called the cochlea 20.

A labyrinth of bones referred to as the ossicular chain 21 spans the middle ear 16 to inner-connect the ear drum 15 with the middle ear 17, at the oval window 19. The ossicular chain 21 conveys the mechanical vibrations of the ear drum 15 to the inner ear

- 18 -

17, thereby causing fluidic vibrations in the perilymph fluid 20a contained in the cochlea 20. Vibrations in the perilymph fluid of the cochlea 20 actuate receptor cells 20b which cause nerve fibers 20c to signal the brain (not shown) of the subject 12 to perceive the vibrations as sound. The ossicular chain 21 includes the malleus 22, the incus 23 and the stapes 24. The stapes 24 includes leg portions 25 and 26 shaped similar to a wishbone and a footplate 27 which covers the oval window 19.

10 Fig. 1 also shows the three major components of auditory system 10, a microsensor 28, a processor 30 and a microactuator 32. A miniaturized electrical cable 33 interconnects the microsensor 28 with the processor 30, and a miniaturized electrical cable 34 interconnects the processor 30 with the microactuator 32. The microsensor 15 28 is mounted adjacent the eardrum 15 and is preferably secured to the incus 23 by a crimped wire or hook 36. The microsensor 28 senses mechanical vibrations of the eardrum 15 and/or one of the bones of the ossicular chain 20 21 and converts the sensed vibrations into electrical signals which are conveyed along cable 33 to processor 30.

The processor 30 is implanted subcutaneously behind the external ear 13 within a hole 38 surgically 25 sculpted in the mastoid cortical bone 39 of the subject 12. The processor 30 conditions the electrical signals. More specifically, the processor 30 separates the electrical signals into a predetermined number of

- 19 -

bandwidths, translates the electrical signals plus or minus one hundred and eighty degrees into proper phase, amplifies the electrical signals and then conveys the conditioned electrical signals along cable 34 to the
5 microactuator 32. The microactuator 32 transduces the electrical signals to mechanical vibrations to directly or indirectly vibrate the perilymph fluid 20a in the inner ear 17, thereby actuating the receptor cells 20b to cause the nerve fibers 20c to signal the brain of the
10 subject 12 to perceive the initial mechanical vibrations in the outer ear 14 as sound.

Fig. 1a is a side-view of the subject 12 which depicts the relative positions of the microsensor 28, the processor 30 and the microactuator 32 with respect to the
15 external ear 13. The processor 30 is located subcutaneously so that instructions for operating the controls of this auditory system 10 may be signaled from outside of the subject 12. The microsensor 28 and the microactuator 32 are micromachined components and
20 therefore are of such a small size as to require little or no destruction of human tissue of the subject 12 during surgical implantation. In fact, the micromachined microactuator 32 may be implanted via a presently used laser stapedotomy technique.

25 II. The Electrical System

Fig. 2 schematically depicts the electrical interconnections among the components of this auditory

- 20 -

system 10. More specifically, Fig. 2 shows that processor 30 includes a graphic equalizer 40, a delay filter 41 and a power amplifier 42. The graphic equalizer 40 preferably separates the electrical signals into three or more bandwidths of predetermined audio frequency ranges and also provides gain control of 0-32 dB for those bandwidths which include signals in the audio frequency range of 500-3500 Hz or more. The delay filter 41 performs phase shifting of the electrical signals, if necessary, by plus or minus 180 degrees to avoid constructive or destructive interference. The power amplifier 42 receives the phase shifted signals and amplifies these signals before they are transmitted via cable 34 to microactuator 32. The graphic equalizer 40, the delay filter 41 and a power amplifier 42 interconnect with the power source 44, which is preferably a five to six volt lithium battery, although simulated studies indicate that this voltage may eventually be reduced to three volts.

Each of these components also interconnects with a command interpreter 45 which is located close to the undersurface of the skin of the subject 12. The command interpreter 45 controls operations of the other components of the system 10. For instance, the command interpreter 45 controls the settings for the gain of the different bandwidths separated by the graphic equalizer 40. An initial setting may be made by "burning in" a ROM prior to surgical implantation, with the initial setting

- 21 -

determined by the particular hearing characteristics and/or deficiencies of the subject 12. If desired, these settings may be made variable by a physician or an audiologist, preferably by using an EPROM to minimize surgical procedures. The command interpreter 45 also controls the power amplifier 42 and the power source 44 to increase or decrease the volume or to turn electrical power to the auditory system 10 off or on, respectively.

The command interpreter 45 controls the other components in response to instructions received from outside the subject 12. These instructions may be input via receipt of coded RF signals by a RF receiver 46, receipt of coded light signals by a photodetector 47 or receipt of a coded sequence of applied forces by a pressure sensor 48. If coded RF signals or coded light signals are used to instruct the command interpreter 45, a hand held RF transmitter (not shown) or an infrared transmitter (not shown) may be carried in the pocket of the subject 12, respectively. If the command interpreter 45 is instructed via pressure, the subject 12 instructs the command interpreter 45 by applying a coded sequence of forces, as with a finger, to the skin residing just outside of the pressure sensor 48.

Coding of the input signal reduces the possibility of inadvertent instructing of the command interpreter 45, as may occur, for example, via stray RF signals, stray light signals or forces applied to the head, such as the force of a tight fitting hat.

- 22 -

Preferably, the command interpreter 45 and the other components of the processor 30 operate on lower power CMOS to eliminate the need for a standby current. Also, the processor 30 is preferably encapsulated in a bio-compatible material such a silicone polymer.

III. The Microsensor

Figs. 3 and 3a depict a microsensor 28 constructed in accordance with a first preferred embodiment of the invention. More particularly, Fig. 3 depicts a microsensor 28a which comprises a piezoresistive vibration sensor micromachined out of a single semiconductor crystal or substrate 50 of n-type material. The crystal 50 is most likely silicon, though gallium arsenide may also be suitable. The crystal 50 is etched from a top surface 51 and from a bottom surface 52 to provide an inertial or seismic mass 54 cantilevered by two parallel support arms 55, as shown in Fig. 3a. Five conductive metallic electrodes 57 are deposited on the top surface 51 of crystal 50 by electron beam evaporation or any other suitable deposition or metallization technique. Preferably, four p-doped piezoresistive regions 58 reside beneath the ends of the conductors 57, at the support arms 55, to form an integrated Wheatstone bridge for sensing vibration of the seismic mass 54. Electrical leads 59 connect to electrodes 57 to provide power and to convey a generated electrical signal to and along cable 33. Preferably, a

- 23 -

passivation layer 60 resides adjacent the top surface 51 of the crystal 50.

If desired, additional trimming resistors 58a for temperature compensation may be deposited on crystal 50. Additional metallization, designated generally by reference numeral 57a, may be used to vary or control the steady state current through piezoresistors 58 via interconnection with resistors 58a. Contacts 57b enable the crystal 50 to be tested for diffusion, and electrical contact 57b connects directly with the crystal 50.

With this microsensor 28 mounted to one of the bones of the ossicular chain 21, mechanical vibrations of the ossicular chain 21 and/or the eardrum 15 also cause movement of the seismic or inertial mass 54. Forces applied to the support arms 55 by movement of the inertial mass 54 generate changes in the resistance of the piezoresistors 58, thereby resulting in change in current along the conductors 57.

Preferably, the microsensor 28a is hermetically sealed between upper and lower caps 62 and 63, respectively. Each of the caps 62 and 63 includes an etched depression, 64 and 65, respectively, which permits the inertial mass 54 some freedom of movement but also act as an air damper. The depressions 64 and 65 each include raised centers 66 and 67, respectively, which limit movement of the inertial mass 54 to prevent breakage. Because of the extremely small sizes which may be achieved through micromachining techniques of the type

- 24 -

used to form this microsensor 28a, the mass of this microsensor 28a may be as low about 20 mg. This microsensor 28a is more completely described in a Doctoral Dissertation entitled "DEVELOPMENT OF A FULLY
5 INTEGRATED MICROMACHINED PIEZORESISTIVE ACCELEROMETER/VIBRATION SENSOR WITH INTEGRAL AIR DAMPING FOR CONDITION MONITORING", and presented in 1992 by Kevin M. Walsh, which is expressly incorporated herein by reference, in its entirety.

10 Figs. 4 and 4a depict a microsensor 28 constructed in accordance with a second preferred embodiment of the invention. More particularly, Fig. 4 depicts a micromachined capacitive microsensor 28b for sensing mechanical vibrations and converting the
15 mechanical vibrations to electrical signals. The microsensor 28b is micromachined out of a single semiconductor crystal 70 such as silicon with a <100> orientation. A top surface 71 of the crystal 70 is passivated to form an electrically insulative layer 73
20 of either silicon dioxide, SiO_2 , or silicon nitride, Si_3N_4 , and a central portion of a bottom surface 72 is etched all the way through to remove all but the top layer 73 and a central inertial mass 75 or hillock.

A substrate 74 is bonded to the bottom surface
25 72 to enclose the etched space of the crystal 70. If made of glass, the substrate 74 is electrostatically bonded to surface 72. A conductive capacitor electrode layer 78 of aluminum or gold is deposited on the inside

- 25 -

surface of the substrate 74. Alternatively, layer 78 may be polycrystalline silicon on glass or the substrate 74 may be single crystalline silicon electrostatically bonded across a glass or silicon dioxide SiO_2 surface to the base crystal 70. Preferably, the conductive layer 78 covers the area that was etched from bottom surface 72. The conductive layer 78 ultimately connects to a lead 81b electrically connected to the bottom surface 72 of the crystal 70, similar to the electrical connection shown for the sensor in Fig. 3.

A metallization film 79 covers top surface 71, and another electrical lead 81a is bonded to the metallization film 79, which serves as the upper capacitive electrode. The leads 81a and 81b are aluminum or preferably gold, which is biocompatible. The leads 81a and 81b connect to electrical wires carried within cable 33 (not shown). The hillock 75 may be electrically connected to the conductive layer 79, via region 79a, as shown in Fig. 4, or the hillock 75 may be isolated from layer 79 by extending layer 73 all the way across crystal 70.

With a voltage applied to leads 81a and 82b, this microsensor 28b acts as a parallel plate capacitor, with layer 78 acting as one plate and film 79 and hillock 75 acting as the other plate. When mounted to one of the bones of the ossicular chain 21, mechanical vibrations of the ossicular chain couple into the hillock 75 as an inertial or seismic mass which will cause relative

- 26 -

movement between hillock 75/electrode 79 and substrate 74 to produce capacitance fluctuations. These capacitance fluctuations are detected by conductive leads 81a and 81b and may be converted to voltage signals to be conveyed to the processor 30 via cable 33.

Compared to a piezoresistive sensor, a micromachined capacitive microsensor 28b of this type requires less electrical current. This results in extended life for the battery 44 for this implanted auditory system 10.

The particular microsensor 28b shown in Fig. 4 works best when mounted to the ossicular chain 21 and used as a vibration sensor for detecting mechanical vibrations thereof. Alternatively, the microsensor 28b may be micromachined without a hillock 75 and mounted anywhere in the middle ear 16 to act as an acoustical microphone, rather than as a vibration sensor. When used as an acoustical microphone for sensing air pressure waves, performance is optimized if the plates are as thin and uniform as possible, thereby to maximize relative movement therebetween.

Fig. 5 shows microsensor 28a or 28b secured to the incus 23 via crimped wires 36a and 36b.

IV. The Microactuator

Figs. 6 is a cross-sectional schematic view which depicts a microactuator 32 implanted in the subject 12 in accordance with a first preferred embodiment of the

- 27 -

invention. More particularly, Fig. 6 depicts a microactuator 32a located within an externally threaded screw 82 which is threaded into a surgically formed fenestration 83 in the promontory bone 84 of the subject 12. The screw 82 preferably has an outside diameter of about 2mm. Alternatively, the fenestration 83 may be formed in the footplate 27 of the stapes 24. The fenestration 83 may be formed by present surgical laser techniques or by drilling, depending upon whether the fenestration is formed in the footplate 27 or the promontory 84, respectively. The threads are unnecessary if the fenestration is formed in the footplate 27.

Preferably, the screw 82 is made of gold alloy or of gold so as to be biocompatible, and the screw 82 has an insulative layer 86 coated along the inside surface of a bore 85 formed therethrough. The microactuator 32a is preferably formed from a single semiconductor crystal 80 of silicon with a crystalline orientation of $\langle 100 \rangle$ and doped to a resistivity of 10 ohm-cm or less and then mounted within a forward end of the bore 85.

The crystal 80 is micromachined through a top surface 87 thereof to form a flexible diaphragm 88 with an outer surface 89 which is in direct contact with the fluid 20a of the inner ear 17 after surgical implanting. The flexible diaphragm 88 is spaced from a remainder or major portion 80a of the crystal 80, with a space 90 located therebetween. The space 90 is actually an etched

void having a thickness of about one to five microns, and this etched void 90 is etched via access holes 93 (Fig. 7) which extend from top surface 87 and through portion 80a.

5 The void 90 represents the volume previously occupied by a sacrificial layer formed on the bottom of crystal 80 prior to formation of a passivation layer. The sacrificial layer must be formed of a material which is susceptible to an etchant which does not etch the
10 major portion 80a and the diaphragm 88. The actual material used to form the sacrificial layer or the etchant may vary, depending upon the characteristics of the starting material, i.e. the crystal 80.

 The flexible diaphragm 88 is actually one
15 section of a passivation layer 94 of silicon dioxide or silicon nitride which extends completely around the external surface of the crystal 80. This passivation layer is electrically nonconductive. Diaphragm 88 is preferably 0.10 to 1.0 microns in thickness and has
20 length and width dimension of about 1.0-1.5 millimeters x 1.0-1.5 millimeters.

 In one approach for micromachining microactuator 32a, the spacing or void 90 between the electrodes may be formed by a sacrificial layer etch-away
25 technique. First, silicon dioxide is thermally grown on the surface of the silicon wafer 80 to a thickness on the order of one to several microns (micrometers). Then circular silicon dioxide islands are photolithographically

- 29 -

formed by ordinary semiconductor patterning techniques, and the complete surface is coated with a layer 94 of silicon nitride (typically by reactive ion sputtering or low-pressure chemical-vapor-deposition) to a thickness on the order of one half to two microns. Part of this layer 94 serves as the lower vibrating membrane 88 of the micromachined capacitive microactuator 32a. The surfaces of the <100> silicon crystal 80 are processed using an appropriate combination of anisotropic (KOH, EDP or hydrazine) or isotropic etching (typically nitric, hydrofluoric, acetic acid combination) to provide the access holes 93 for subsequently etching away the sacrificial silicon dioxide layer near the bottom side. For selectively removing the silicon dioxide sacrificial layer, the etchant will typically be a hydrofluoric acid solution. The access holes 93 take advantage of the nonetching <111> crystallographic planes using silicon anisotropic micromachining technology (or a plasma RIE may be used).

Several other combinations may be used for the sacrificial layer, such as n or n+ doped silicon surface (ion-implanted, pre-deposition thermally diffused or epitaxially grown) on top of a p+ silicon substrate which serves as an etch stop as well as a highly conductive electrode. In the latter case, an etchant access hole must be provided to the n or n+ layer, such as by reactive ion etching (RIE) through the p+ region. The lab experiences of one of the inventor's has revealed

- 30 -

that an aqueous solution of hydrazine will preferentially etch the n+ region away, leaving the narrow space or void 90 necessary for movement of the diaphragm 88, even if the remaining body of the crystal is n type rather than p+.

The outer area of the screw 82 may contain slots for an insertion tool, flats or similar means for tapping the screw 82 through the bony tissue of the promontory 84. The screw 82 electrode may be soldered, welded or may consist of a contacting metal washer. The bottom of the screw 82 will extend below the delicate actuator membrane 88 to protect it during installation.

The diaphragm 88 may also comprise an electrochemically etch-stopped epitaxial layer of silicon (n on p or p on n). However, because of the small area required in this case, it is difficult to achieve the thinness necessary, i.e., 0.5 to 2 microns, for low voltage actuation without using silicon nitride or silicon dioxide membranes.

Fig. 6 shows a degeneratively doped (n+ or p+) region 95 near top surface 87 to assure good ohmic contact between the silicon of portion 80a and an above metallized region 96 of aluminum, gold or copper, but this region 95 is not necessary if crystal 80 is highly doped. If the silicon crystal 80 is highly p+, it will also serve as an effective etch stop for ordinary anisotropic etchants (such as KOH or EDP). This region 96 is ultrasonically or thermocompression wire bonded to

- 31 -

an aluminum or gold wire 98 which extends through the bore 85 and is interconnected to an electrical terminal 100, which is in turn connected to an electrode 102 which extends into cable 34. Preferably, the terminal 100 is made of copper or gold, and the electrode 102 is a gold wire or another electrically conductive material coated with teflon so as to be biocompatible. Preferably, as shown in Fig. 7, two electrical connection wires 98 are extended through screw 82 to assure electrical voltage transmission in the event that one of the wire 98 should fail. Fig. 7 also shows that two etched holes 93 are accessed to etch the void 90. The remainder of the inside of the screw 82 is encased within an encapsulant 105, such as silicone polymer.

This microactuator 32a acts as a very small parallel plate capacitor. The processor 30 conveys electrical voltage signals along electrode 102, via electrical terminal 100, wires 98 and connection regions 96 and 95 to the major portion 80a of crystal 80, which acts as one of the conductive plates of the parallel plate capacitor.

One important aspect of this microactuator 32 relates to the use of the ionic nature of the fluid 20a of the inner ear 17 as the other plate of the micromachined capacitor, with the spacing between "plate" 80a and the other "plate", i.e. the inner ear fluid 20a, defined by the combined thickness of the diaphragm 88 and the etched void 90 residing therebetween. The body of

- 32 -

the screw 82 itself serves as an electrode for supplying electrical voltage signals to the fluid of the inner ear 17. A first electrode 106 extends into the bore 85 of the screw 82 and is soldered or welded thereto. If
5 desired, an alternative electrode 107 may be soldered or welded to a washer 108 residing between the head of the screw 82 and the promontory 84. If no washer 108 is used, the alternative electrode 107 may be soldered directly to the head of the screw 82. If desired, a
10 mount 109 may also extend from screw 82 for mounting the microsensor 28 thereon for acoustical pickup from the structure or the surrounding air of the middle ear.

Electrical voltage signals applied to portion 80a and the fluid 20a of the inner ear 17 generate
15 electric fields across space 90 and diaphragm 88. Because of the very small dimensions of space 90 and diaphragm 88, i.e. six microns at most, relatively small applied voltages will generate large electric fields. The magnitude of the generated electric fields causes
20 electrostatic forces to act on the diaphragm 88, resulting in mechanical vibrations. These diaphragm 88 vibrations directly stimulate or vibrate the fluid of the inner ear 17. The vibrations of the fluid 20a of the inner ear 17 actuate the receptor cells 20b to cause the
25 nerve fibers 20c to signal the brain of the subject 12 to perceive the electrical voltage signals as sound.

For this approach, it is important to maintain good electrical isolation between portion 80a and screw

- 33 -

82, which acts as one of the electrodes and conveys electrical signals to the fluid of the inner ear 17. To accomplish a bond while maintaining this electrical isolation, an additional layer 110 of low melting point glass or another sealant material is preferably deposited between the passivation layer 94 and the screw 82 at a point 112 where the bore 85 has a slightly increased diameter for receiving the microactuator 32a. The glass film 110 may be deposited by chemical vapor deposition. The passivation layer 94 also provides electrical isolation. It is believed that the passivation layer 94 and the layer 112 will sufficiently isolate portion 80a from the fluid 20a of the inner ear 17. Other polymeric sealing methods can be used, if necessary. It is desirable for the silicon crystal 80 to be as highly conductive as possible (e.g. p+) because it serves as the inner or upper capacitive electrode.

If it is necessary to assure better electrical isolation, the screw 82 may be made of teflon, an electrically insulative material, with an external coating of electrically conductive material such as gold deposited thereon. According to this alternative approach, one or both of the electrodes 106 and 107 are then bonded to the external surface of the screw 82.

Although the diaphragm 88 could, in principle, be electrically insulated from the perilymph 20a by utilizing electrical contacts anisotropically etched through the crystal 80, this would be difficult because

- 34 -

of the limited space. As stated previously, the outside diameter of the screw 82 is about 2mm in diameter, and the actuator 32a must fit within the body of the screw 82.

5 Fig. 8 is a cross-sectional schematic which depicts a microactuator 32 implanted in the subject 12 in accordance with a second preferred embodiment of the invention. More particularly, Figs. 8 and 8a depict a microactuator 32b which is mounted within a tapered hole or fenestration 115 formed in the promontory 84, as by
10 drilling.

 The microactuator 32b includes a semiconductive crystal 120 of 10 ohm-cm resistivity or less which is <100> crystalline orientation and micromachined, i.e.
15 etched, in this case, to form a tapered, twelve sided shape which may be further rounded by a final isotropic etch if necessary. This shape is dictated or defined by etching a crystal with a <100> orientation. Fenestration 115 is circular and tapered, and is formed by a circular tapered drill. Because the fenestration 115 is circular,
20 it is desirable to shape the crystal 120 so that it closely approximates a circle. The microactuator 32b includes a flange portion 122 which is integral with crystal 120, and the flange shape 122 is formed by
25 selectively etching from the top and the bottom. Miniaturized screws 123 secure the flange 122 to promontory 84 around the outside of the fenestration 115. The crystal 120 is selectively etched from a bottom

- 35 -

surface 125 to leave an outer protective rim 121 which surrounds a recess 121a. A sacrificial layer of selectively unformed thin dimension, i.e., one to five microns, is then formed within the bottom of the recess 121a (or the top, as viewed in Fig. 8), and the crystal 120 is then passivated around its entire external surface.

At least one access hole 126 is then etched from the top surface 124 to the bottom surface 125 of the crystal 120, and then the access hole 126 is used to etch away the sacrificial layer, in much the same manner that void 90 was formed in microactuator 32a, thereby leaving a flexible diaphragm 128 and a major portion 120a of crystal 120 separated by a space or void 129 which is one to five microns thick. The diaphragm 128 preferably has the same thickness as diaphragm 88 and the diameter of the diaphragm 88 is about the same dimension as the diagonal span of rectangular diaphragm 128. Void 129 occupies the volume formerly occupied by the sacrificial layer. Electrical interconnection can then be made between internal major portion 120a and cable 34, so that portion 120a acts as one "plate" of a micromachined parallel plate capacitor.

The bottom surface 125 of the diaphragm 128 resides in direct contact with the perilymph fluid 20a of the inner ear 17. An outer passivation layer 120b or surface of crystal 120 may be coated with a metallization layer 120c in selected regions. Thus, the fluid 20a of

- 36 -

the inner ear 17 may serve as the other "plate" of the micromachined parallel plate capacitor, if layer 120c does not cover layer 120b at diaphragm 128. Alternatively, if the layer 120c does cover the diaphragm 5 128, this portion of layer 120c acts as the other "plate". For either approach, the electrical interconnection of the fluid 20a to cable 34 may be via an electrical lead 107 attached beneath screw 123 or bonded to a washer (not shown) located beneath screw 123.

10 Alternatively, a throughhole may be etched through crystal 120 from top surface 124 to bottom surface 125 and then a microactuator of the type depicted in Fig. 6 may be physically located inside the throughhole. In this manner, the crystal 120 would 15 simply serve as a housing for the microactuator, similar to the function formed by the screw 82 depicted in Fig. 6.

Figs. 9 and 9A are schematic cross-sections which depict two variations of a third embodiment of a 20 microactuator 32 in accordance with the invention. More particularly, Fig. 9 depicts a microactuator 32c which utilizes electrostatic actuation for directly vibrating the fluid in the inner ear 17, and microactuator 32c is a micromachined parallel plate capacitor similar to 25 microactuators 32a and 32b, but microactuator 32c does not utilize the perilymph fluid 20a as one of the "plates".

- 37 -

A semiconductor crystal 130 of $\langle 100 \rangle$ crystalline orientation and 10 ohm-cm or less resistivity is selectively micromachined to form a parallel plate capacitor with a conductive diaphragm 132 which is preferably made of polysilicon film. The flexible diaphragm 132 is located in the middle ear 16, outside of a fenestration 131 formed in the promontory 84. A piston 134 connects to the diaphragm 132, as by a screw 135. The head of the screw 135 is eutectically bonded to diaphragm 132, or by a direct gold silicon bond 136 formed therebetween. Piston 134 is preferably gold plated metal, silicon dioxide fiber or teflon. The diameter of the fenestration 131 and the piston 134 must be close enough to prevent leakage of fluid 20a. The conductive diaphragm 132 is supported by a flange-shaped portion of crystal 130 which includes an electrically insulating region or interior shell 138 which is selectively coated, i.e., metallized, on its outside surface by a conductive region 140 which conveys electrical signals to the conductive diaphragm 132. Vibration of the flexible diaphragm 132 causes piston 134 to vibrate, thereby directly stimulating the fluid 20a of the inner ear 17.

In this approach, compared to microactuators 32a and 32b, the diameter of fenestration 131 may be reduced, which may be advantageous medically. Moreover, the cross-sectional area of the two plates is also increased, which promotes stronger electrostatic

- 38 -

actuation forces. This embodiment of the invention is advantageous in instances where access to promontory 84 is limited, or for one reason or another it is desirable to surgically form a fenestration 130 with a reduced diameter and/or to enlarge diaphragm area. The piston 134 will be sealed from leakage of perilymph fluid by employing standard techniques presently used for mechanical prostheses.

Fig. 9a shows another variation of this approach. In Fig. 9a, a diaphragm comprises an electrically conductive outer layer 142, which is preferably polysilicon but may be gold, and on interior electrically insulating layer 138, as in Fig. 9.

Fig. 10 depicts a microactuator 32 constructed in accordance with the fourth embodiment of the invention. More particularly, Fig. 10 depicts a microactuator structure 32d housed within a piston 145 which extends through a fenestration 146 surgically formed in the stapes footplate 27.

Present stapedotomy techniques, including laser surgery stapedotomy, include passive stimulation of the fluid 20a of the inner ear 17 via movement of a piston extended through fenestration in the stapes footplate and anchored to one of the bones of the ossicular chain. In this presently used technique, as described previously, vibrations of the ossicular chain 21 passively vibrate the fluid 20a of the inner ear 17. Fig. 10 shows a wire

- 39 -

crimp attachment 148 formed in the shape of a hook connected to the incus 23, and with upper portions of legs 25 and 26 removed from the stapes 25 to make room for the piston 145.

5 This aspect of the invention utilizes present stapedotomy techniques by incorporating a microactuator of the type depicted in Fig. 6 or Fig. 8 into the piston 145, which is shown in Fig. 10, so that in addition to passive transmission of mechanical vibrations to the
10 fluid 20a of the ear 17, this microactuator structure 32d also amplifies these mechanical vibrations. The components of microactuator structure 32d which are housed inside of piston 145 are encapsulated therein with a coating of biocompatible material such as silicone
15 polymer 150. As with microactuators 32a and 32b, for microactuator structure 32d the housing, i.e., the surfaces of the piston 145, may be used as an electrode to convey electrical signals to the ionic fluid 20a of the inner ear 17.

20 The primary advantage of this approach relates to the fact that it utilizes a surgical technique which has been approved by the FDA of the United States Government and is currently used by a number of audiologists presently practicing in the United States.

25 The previous four embodiments of the microactuator 32 rely upon direct vibration of the fluid 20a of the inner ear 17 via direct contact between the fluid 20a and a diaphragm or a piston secured to a

- 40 -

diaphragm. Figs. 11, 12 and 13 depict another approach of this invention which relies upon indirect stimulation or vibration of the fluid 20a of the inner ear 17. With indirect stimulation, the microactuator 32 includes a flexible diaphragm which vibrates in contact with one of the bones of the ossicular chain 21, thereby amplifying the normal mechanical vibrations of the ossicular chain 21. This approach is less surgically invasive than the other approaches which require the surgical forming of a fenestration.

Fig. 11 shows a microactuator 32e secured in contact with the stapes footplate 27 via wire retainers formed in the shape of hooks 152 connected to legs 25 and 26. Microactuator 32e is almost identical to microactuator 32d, but of a smaller length. Microactuator 32e includes a cylindrical housing 155 which houses the actuation components of the type depicted in Fig. 6. These components are located so that the diaphragm or a piston connected thereto is in contact with the footplate 27, and preferably spring-loaded into contact therewith. Vibration of the diaphragm will vibrate the footplate 27, thereby indirectly vibrating the fluid 20a. Encapsulative material 156 fills the remaining portion of the cylinder 155, and an outer coating 158 is sealed thereabout and may by itself be used as an alternate mounting technique. Electrical leads 159 and 160 supply electrical signals from cable 34 to microactuator 32e.

- 41 -

Fig. 11 depicts microactuator 32e in a non-inertially grounded condition because the microactuator 32 is simply connected to one of the bones of the ossicular chain 21. Figs. 12 and 13 show variations of the fifth embodiment of this invention wherein
5 microactuator 32e is inertially grounded to the promontory 84. More specifically, Fig. 12 shows microactuator 32e attached or bonded via a hole 162 to one end of a plate 164. Screws 165 anchor the other end
10 of the plate 164 to the promontory 84. In this variation of the fifth embodiment, vibrations of the diaphragm of the microactuator 32e vibrate a piston 167 which is secured thereto, thereby vibrating the footplate 37 and stimulating the fluid 20a of the inner ear 17.

15 Fig. 13 shows microactuator 32e inertially grounded to the promontory via plate 164, using screws 165. A wire 168 formed in the shape of a hook encircles a portion of the incus 23 and connects the diaphragm to the incus 23 via piston 167. Again, vibrations of the
20 diaphragm of the microactuator 132e vibrate the piston 167. Vibrations of the piston 167 are translated to the incus 23 via the wire 168, thereby to amplify the natural vibrations of the incus 23, which vibrations are then transmitted via the stapes 24 to the fluid 20a of the
25 inner ear 17.

With the variation of the invention depicted in Fig. 13, the incus 23 and the stapes 24 must be interconnected in normal fashion. For the variation of

- 42 -

the invention depicted in Fig. 11, while it is desirable that the other bones of the ossicular chain 21 remain intact, it is not absolutely necessary because the microactuator 32e is mounted directly to the stapes 24.

5 For the variation of the invention depicted in Fig. 12, one of the legs 26 of the stapes 24 must be surgically removed.

Fig. 14 shows a microactuator 32f formed from two crystals 200 and 201. Crystal 201 is passivated with silicon nitride on its bottom surface 203. Both crystals

10 200 and 201 are etched on respective top surfaces, 204 and 205, to leave a diaphragm 208 of crystal 201 located above a void 209 in crystal 200. The crystals 200 and 201 are then bonded together. Electrical connection is

15 made to crystal 200, which acts as one of the plates, and the crystal 201 is mounted so that diaphragm 208 is in contact with the perilymph 20a.

These various approaches of this invention provide a wide range of versatility for the surgeon in

20 implanting the microactuator 32 in a subject 12 to overcome a hearing deficiency, for almost any type of ear anatomy, whether normal or abnormal.

While several preferred embodiments have been described, it is to be understood that applicant does not

25 wish to be limited thereby. Numerous variations of the components of the invention may be possible, depending upon the type of hearing deficiency and the anatomy of the ear of a particular subject. The invention in its

- 43 -

broader aspects is therefore not limited to the specific details of the representative apparatus, methods and examples shown and described. Accordingly, departures may be made from such details without departing from the spirit or scope of applicants' general inventive concept.

5

- 44 -

What is claimed is:

1. An auditory system adapted to be implanted into a human subject comprising:

5 a microsensor adapted to be implanted in the middle ear of the patient, the microsensor adapted to sense sound waves in the middle ear and to generate electrical signals in response to said sound waves.

10 processing means operatively connected to the microsensor and adapted to receive and process the electrical signals generated by the microsensor, the processing means adapted to be implanted subcutaneously in the subject and including a battery to supply electrical power to the system; and

15 a microactuator adapted to be implanted in the middle ear and operatively connected to the processing means, the microactuator adapted to receive the processed signals and in response thereto to generate electrostatic forces which vibrate the fluid of the inner ear, thereby to actuate auditory nerve fibers which signal the brain of the subject to perceive the fluid vibrations as sound.

- 45 -

2. The auditory of claim 1 wherein the microsensor is micromachined from a semiconductor crystal.

3. The auditory system of claim 2 wherein the micromachined microsensor comprises a piezoresistive vibration sensor adapted to sense said sound waves by sensing mechanical vibrations of the ossicular chain.

4. The auditory system of claim 2 wherein the micromachined microsensor comprises a capacitive vibration sensor adapted to sense said sound waves by sensing mechanical vibrations of the ossicular chain.

5. The auditory system of claim 4 wherein the micromachined microsensor comprises a capacitive acoustical microphone adapted to sense said sound waves by sensing acoustical pressure waves in the inner ear.

6. The auditory system of claim 2 and further comprising:

means for attaching the microsensor to one of the bones of the ossicular chain.

7. The auditory system of claim 2 wherein the microsensor has a mass of less than 30 mg.

8. The auditory system of claim 1 wherein the processing means is adapted to be implanted subcutaneously in the mastoid cortical bone behind the ear of the subject, the invention further comprising:

means for instructing the subcutaneously located processing means to connect and disconnect the battery to the processing means, thereby to turn electrical power "on" and "off" for the system, respectively, the instructing means further adapted to receive an input from outside the body of the subject.

9. The auditory system of claim 8 wherein the instructing means comprises an RF receiver for receiving RF signals transmitted from outside the subject's body.

10. The auditory system of claim 8 wherein the instructing means comprises a photodetector for receiving signals transmitted from outside the subject's body.

11. The auditory system of claim 8 wherein the instructing means comprises a pressure sensor adapted to respond to forces applied from outside the body of the subject.

12. The implanted auditory system of claim 8 wherein the means for processing further comprises:

means for amplifying the electrical signals, the instructing means operatively connected to the amplifying means to enable the subject to selectively increase or decrease the magnitude of amplification of the electrical signals.

13. The implanted auditory system of claim 12 wherein the processing means further comprises:

means for separating the electrical signals into a predetermined number of bandwidths, each bandwidth representing a particular audible frequency range; and

the amplifying means adapted to amplify each of the bandwidths to a preferred setting.

14. The implanted auditory system of claim 13 wherein the processing means further comprises:

means for selectively varying the preferred settings of the bandwidths.

15. The auditory system of claim 1 wherein the microactuator comprises a micromachined semiconductor crystal with a flexible diaphragm spaced across a void from a major portion of the crystal, wherein the diaphragm vibrates in response to said generated electrostatic forces to vibrate the fluid of the inner ear.

16. The auditory system of claim 15 and further comprising:

means for mounting the micromachined microactuator in a fenestration so that the diaphragm directly contacts and vibrates the fluid of the inner ear.

17. The auditory system of claim 16 wherein the mounting means further comprises:

a threaded screw adapted to be threadably extended into a fenestration formed in the promontory, the micromachined microactuator located inside the screw.

18. The auditory system of claim 16 wherein the mounting means is integrally formed with the crystal and the crystal is tapered.

19. The auditory system of claim 16 wherein the diaphragm is a dielectric and the means for mounting includes means for electrically connecting the processing means to the fluid of inner ear, whereby the fluid of the inner ear and said major portion of the crystal act as the plates of a parallel plate capacitor to generate said electrostatic forces across the void and the diaphragm.

20. The auditory system of claim 15 and further comprising:

a piston connected to the flexible diaphragm and adapted to extend through a fenestration in the stapes footplate; and

means for mounting the micromachined microactuator so that the diaphragm directly contacts and vibrates the fluid of the inner ear.

21. The auditory system of claim 20 and wherein the diaphragm is a dielectric and the means for mounting includes means for electrically connecting the processing means to the fluid of inner ear, whereby the fluid of the inner ear and said major portion of the crystal act as the plates of a parallel plate capacitor to generate said electrostatic forces across the void and the diaphragm.

22. The auditory system of claim 21 wherein the mounting means further comprises:

means for connecting the microactuator to the incus.

23. The auditory system of claim 15 and further comprising:

means for mounting the micromachined microactuator so that the diaphragm contacts the stapes footplate so that vibrations of the flexible diaphragm amplify mechanical vibrations thereof, thereby to indirectly vibrate the fluid of the inner ear.

24. The auditory system of claim 15 and further comprising:

a piston having a first end and a second end, the first end connected to the diaphragm; and

means for mounting the second end of the piston in contact with one of the bones of the ossicular chain so that vibrations of the diaphragm correspondingly vibrate the piston to amplify the mechanical vibrations of the ossicular chain, thereby to indirectly vibrate the fluid of the inner ear.

25. An auditory system for implanting into a human subject comprising:

means for sensing sound waves in the inner ear of the subject and converting the sensed waves to electrical signals;

signal conditioning means operatively connected to the sensing means and adapted to condition the electrical signals;

electrical power supply means operatively connected to the sensing means and the conditioning means to provide electrical power thereto; and

a micromachined microactuator operatively connected to the conditioning means and adapted to receive the conditioned electrical signals and to convert the signals into electric fields for electrostatically causing vibrations in the fluid of the inner ear when the auditory system is implanted in the subject, whereby the vibrations actuate receptor cells and nerve fibers to signal the brain of the subject to perceive the acoustic pressure waves as sound.

26. The auditory system of claim 25 wherein the micromachined microactuator is formed from a single crystal and includes a diaphragm spaced across a narrow void from a major portion of the crystal, the diaphragm being sufficiently thin to vibrate in response to changes in the magnitudes of said electric fields, thereby to cause the fluid of the inner ear to vibrate.

27. The auditory system of claim 22 and further comprising:

means for mounting the microactuator in a fenestration to place the diaphragm in direct contact with the fluid of the inner ear to directly vibrate said fluid, and

means for electrically connecting the fluid of the inner ear with the signal conditioning means, whereby the major portion of the crystal and the fluid of the inner ear act as the spaced plates of a parallel plate capacitor to establish the electric fields which vibrate the diaphragm and thereby cause the fluid of the inner ear to vibrate.

28. The auditory system of claim 26 and further comprising:

means for mounting the diaphragm in contact with one of the bones of the ossicular chain of the subject to amplify mechanical vibrations thereof and thereby indirectly vibrate the fluid of the inner ear.

29. The auditory system of claim 28 and further comprising:

a piston having a first end rigidly connected to the diaphragm; and,

means for mounting a second end of the piston in contact with one of the bones of the ossicular chain, whereby vibration of the diaphragm vibrates the piston and amplifies the normal vibrations of the ossicular chain, thereby to indirectly vibrate the fluid of the inner ear.

30. The auditory system of claim 29 and further comprising:

means for inertially grounding the microactuator to the promontory bone.

31. A method for reducing conductive and/or sensorineural hearing deficiency in a human subject comprising the steps of:

conveying electrical signals to a micromachined microactuator implanted in the middle ear of a subject, the micromachined microactuator including a major portion and a flexible diaphragm spaced therefrom, with a void therebetween; and

generating electrostatic forces across the void in response to the electrical signals, whereby changes in the electrostatic forces vibrate the diaphragm and said diaphragm vibrations stimulate the fluid of the inner ear of the subject to signal the brain of the subject to perceive said diaphragm vibrations as sound.

32. The method of claim 31 wherein said vibrations of the diaphragm directly stimulate the fluid of the inner ear of the subject.

33. The method of claim 32 wherein the diaphragm resides in contact with the fluid of the inner ear of the subject to directly stimulate said fluid.

34. The method of claim 31 wherein the vibrations of the flexible diaphragm indirectly stimulate the fluid of the inner ear.

35. A method for reducing conductive and/or sensorineural hearing deficiency in a human subject comprising the steps of:

micromachining a single crystal to form a microactuator with a conductive portion spaced away from a flexible diaphragm by an etched void;

implanting said micromachined microactuator in the subject; and

electrically connecting the micromachined microactuator to a source of electrical signals, whereby changes in electrical signals conveyed from the source to the microactuator and applied across the void generate electrostatic forces which cause the diaphragm to vibrate, thereby to stimulate the fluid of the inner ear to reduce the hearing deficiency of the subject.

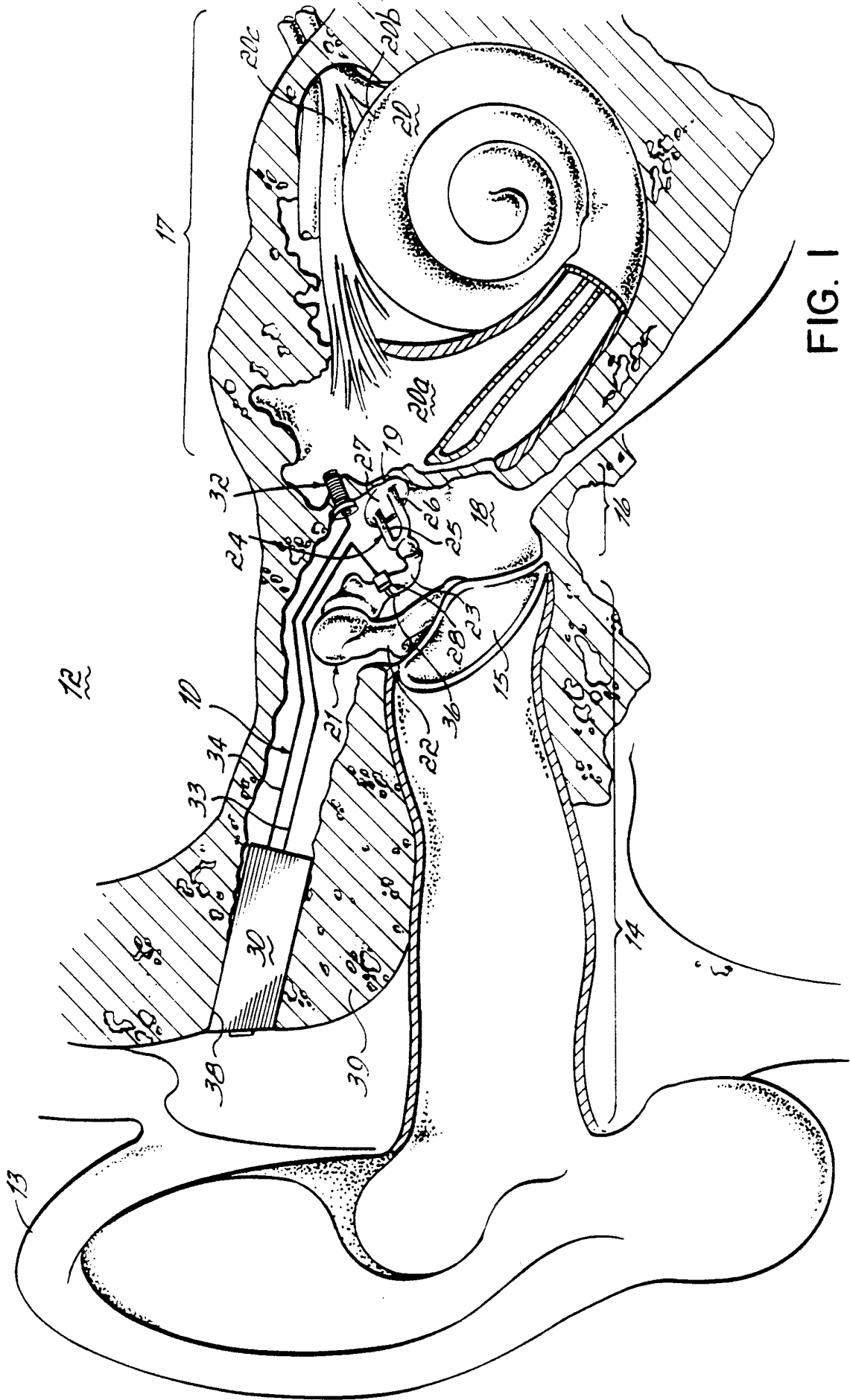

FIG. 1

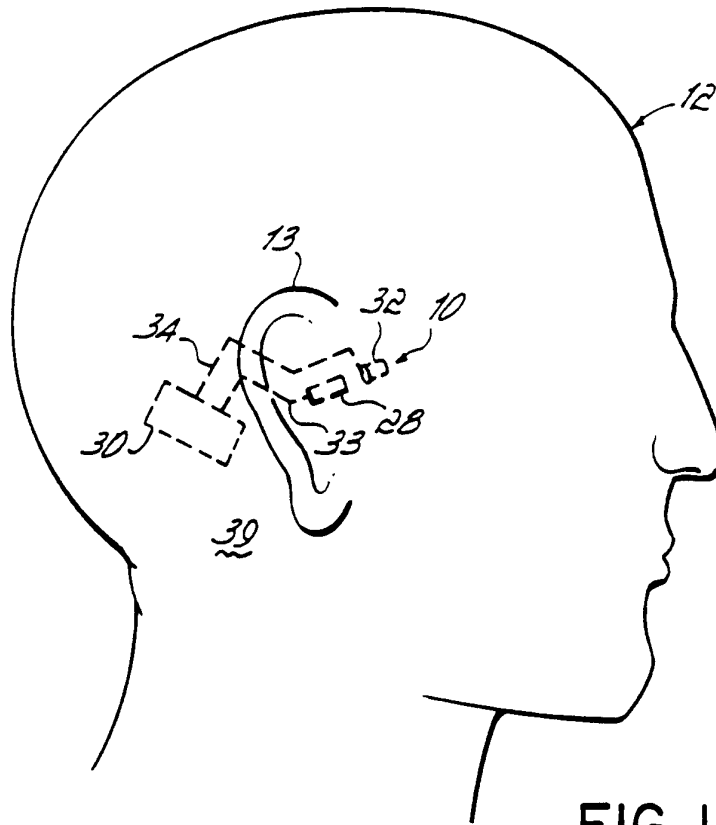

FIG. 1A

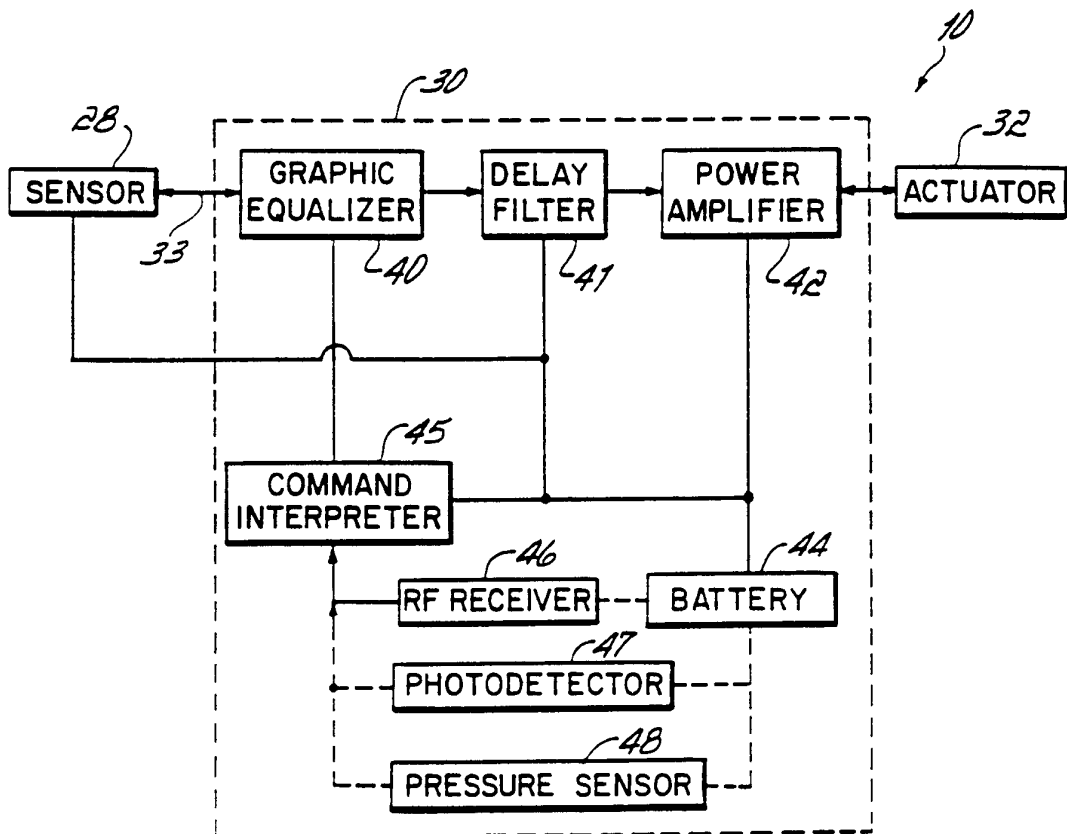

FIG. 2

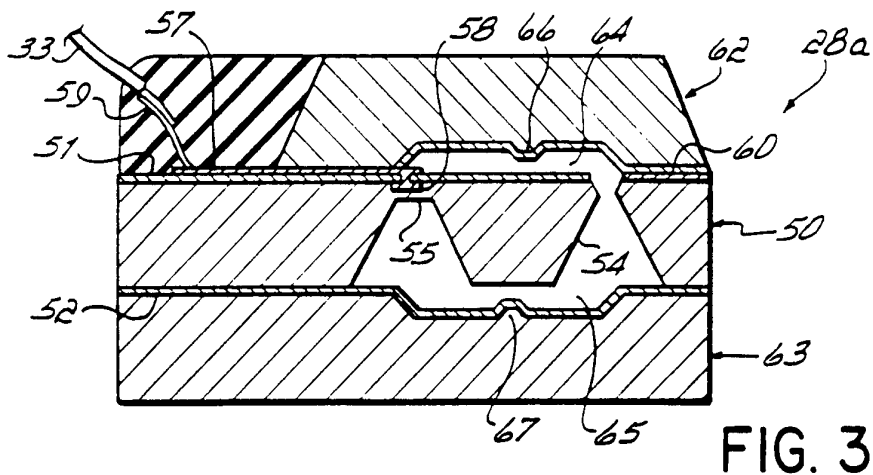

FIG. 3

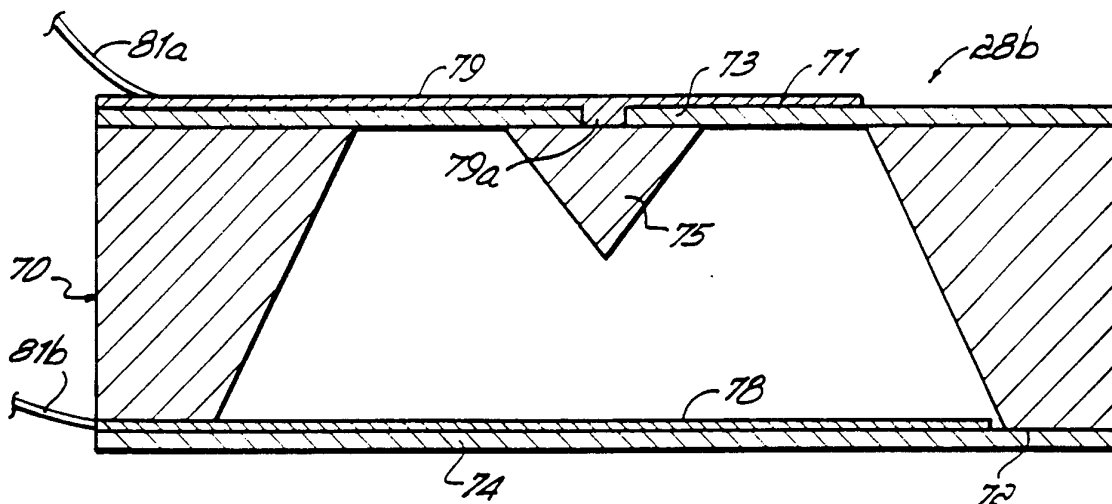

FIG. 4

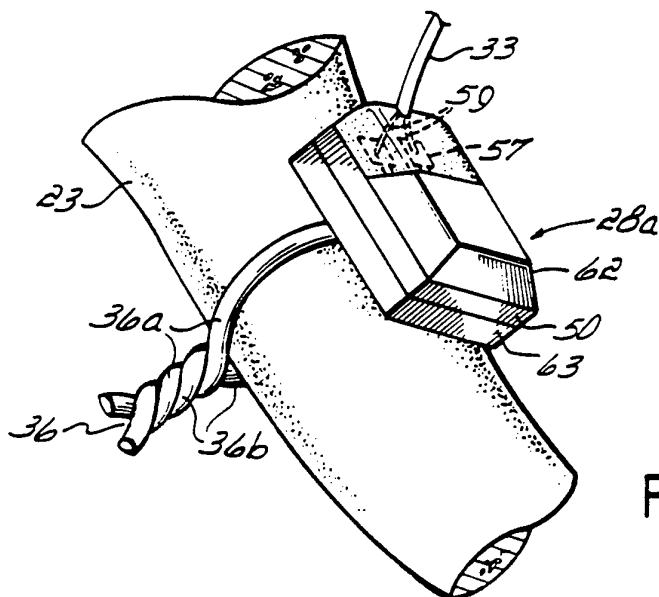

FIG. 5

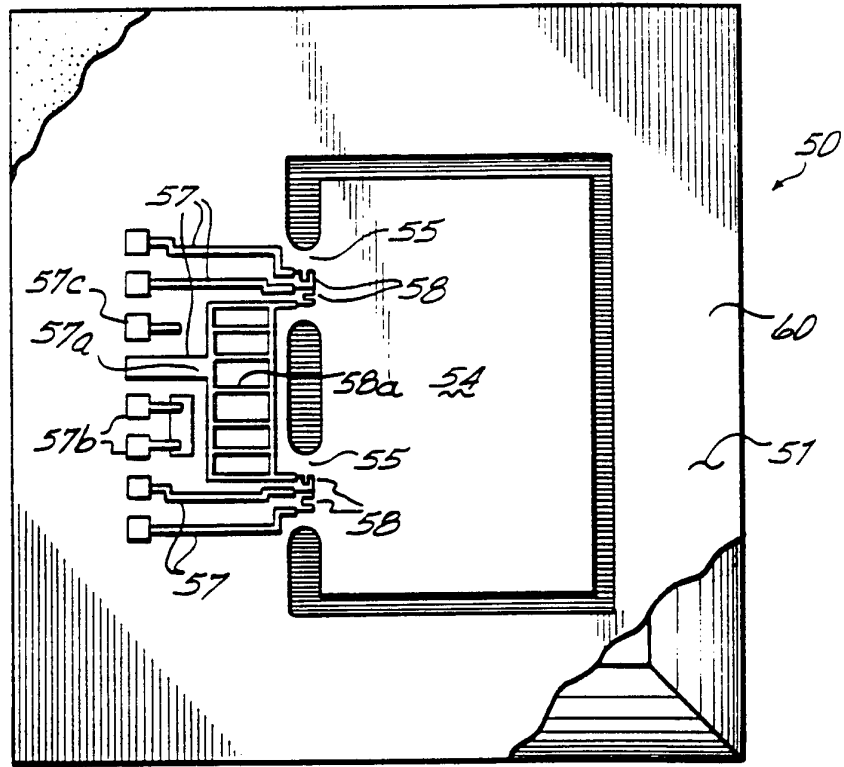

FIG. 3A

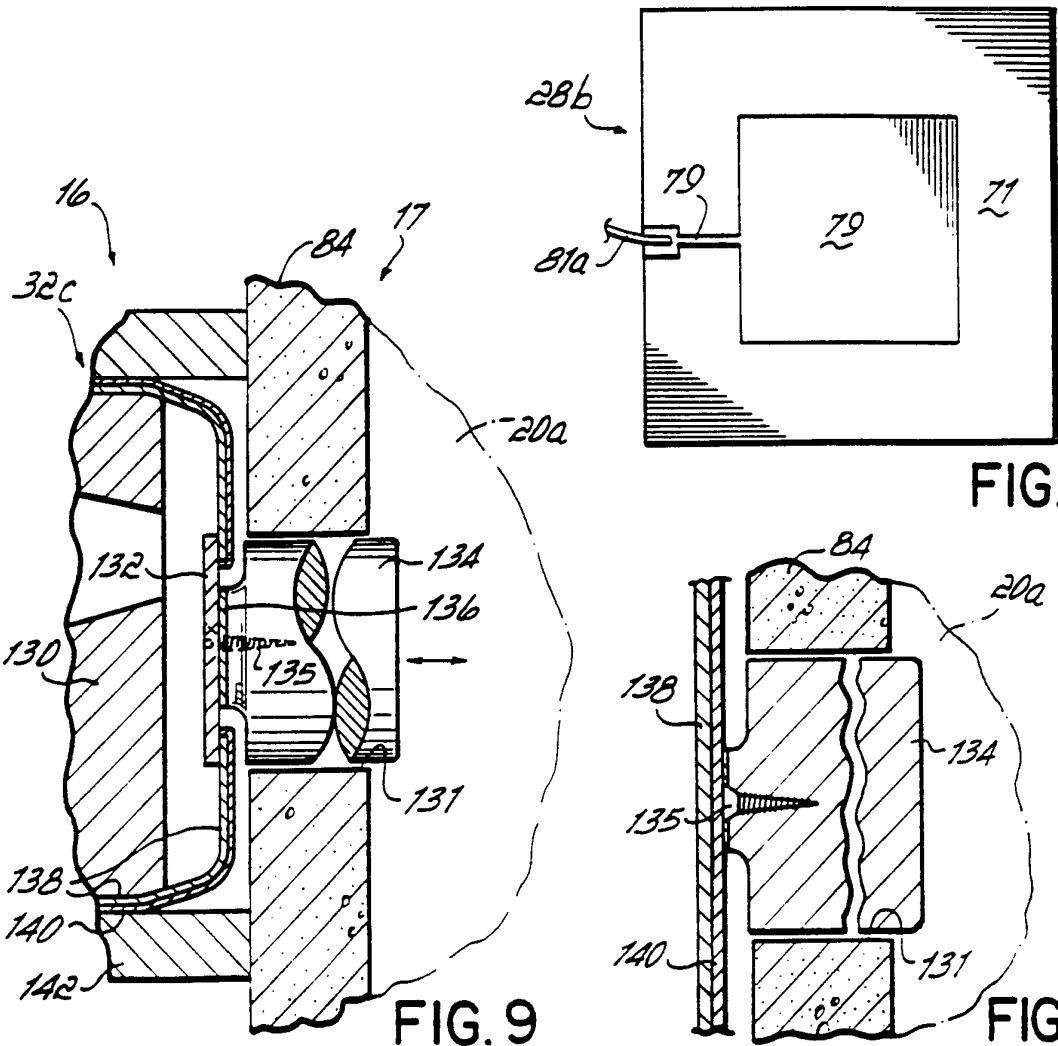

FIG. 9

FIG. 4A

FIG. 9A

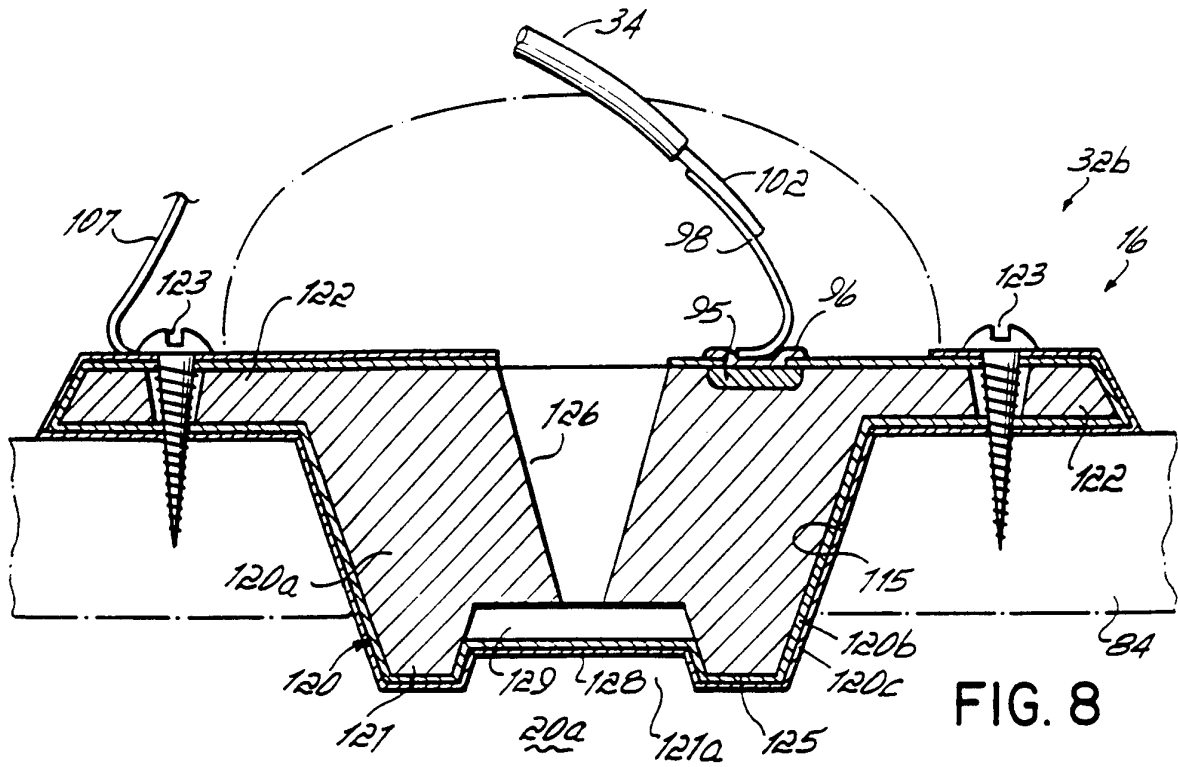

FIG. 8

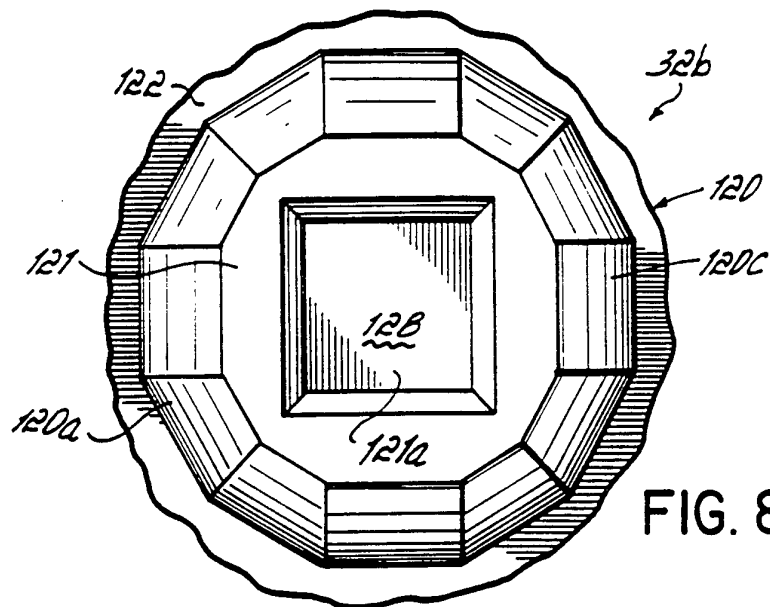

FIG. 8A

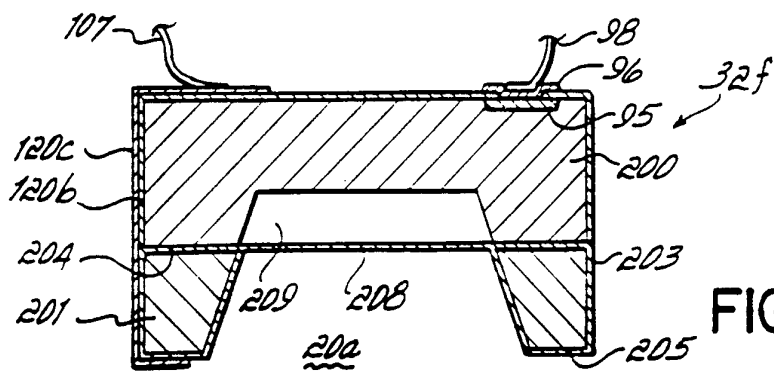

FIG. 14

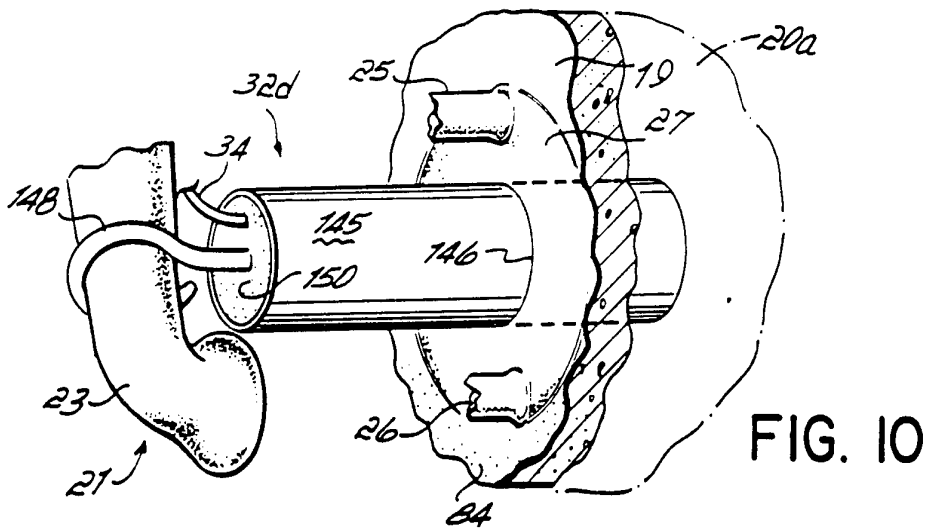

FIG. 10

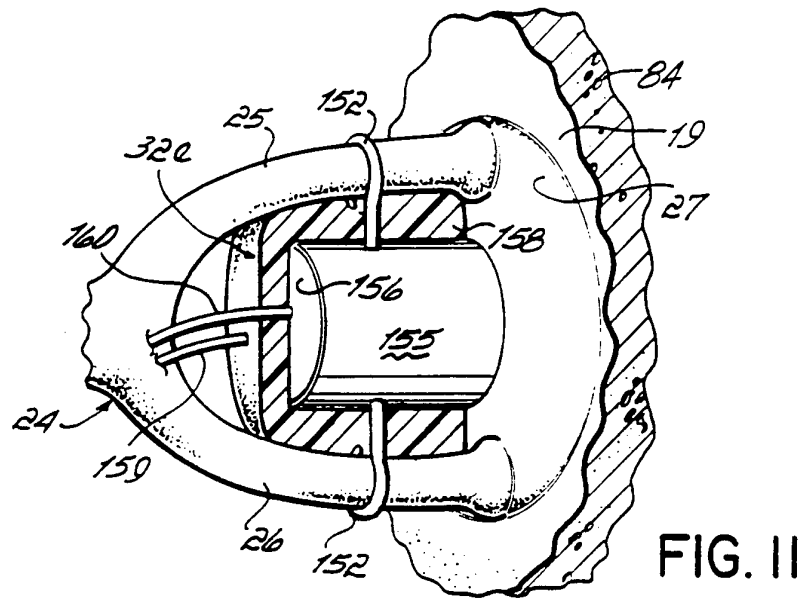

FIG. 11

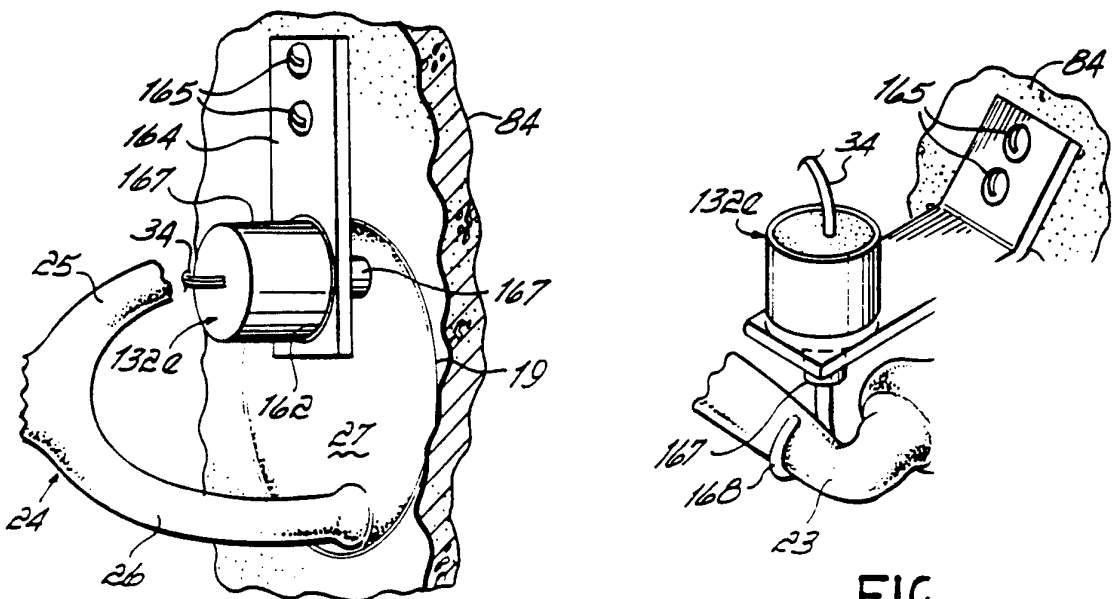

FIG. 12

FIG

INTERNATIONAL SEARCH REPORT

Internat. Application No.
PCT/US 94/00853

A. CLASSIFICATION OF SUBJECT MATTER
IPC 5 H04R25/00 A61F11/04

According to International Patent Classification (IPC) or to both national classification and IPC

B. FIELDS SEARCHED

Minimum documentation searched (classification system followed by classification symbols)
IPC 5 H04R A61F H02N G01L A61N G01N

Documentation searched other than minimum documentation to the extent that such documents are included in the fields searched

Electronic data base consulted during the international search (name of data base and, where practical, search terms used)

C. DOCUMENTS CONSIDERED TO BE RELEVANT

Category*	Citation of document, with indication, where appropriate, of the relevant passages	Relevant to claim No.
A	US,A,4 988 333 (ENGBRETSON ET AL.) 29 January 1991 see column 1, line 7-12 see column 2, line 57 - column 3, line 26 see column 3, line 45 - column 7, line 2 ---	1,6,8,9, 11,12, 15,16, 19-35
A	US,A,4 908 509 (SENTURIA) 13 March 1990 see column 1, line 35-42 see column 3, line 45 - column 6, line 63 ---	1-7
A	US,A,4 943 750 (HOWE ET AL.) 24 July 1990 see column 1, line 8-48 see column 4, line 7 - column 5, line 42 see column 7, line 39 - column 13, line 46 see column 15, line 52 - column 16, line 68 ---	1,15-35
-/--		

Further documents are listed in the continuation of box C.

Patent family members are listed in annex.

* Special categories of cited documents :

- "A" document defining the general state of the art which is not considered to be of particular relevance
- "E" earlier document but published on or after the international filing date
- "I" document which may throw doubts on priority claim(s) or which is cited to establish the publication date of another citation or other special reason (as specified)
- "O" document referring to an oral disclosure, use, exhibition or other means
- "P" document published prior to the international filing date but later than the priority date claimed

- "T" later document published after the international filing date or priority date and not in conflict with the application but cited to understand the principle or theory underlying the invention
- "X" document of particular relevance; the claimed invention cannot be considered novel or cannot be considered to involve an inventive step when the document is taken alone
- "Y" document of particular relevance; the claimed invention cannot be considered to involve an inventive step when the document is combined with one or more other such documents, such combination being obvious to a person skilled in the art.
- "&" document member of the same patent family

Date of the actual completion of the international search

19 May 1994

Date of mailing of the international search report

06.06.94

Name and mailing address of the ISA
 European Patent Office, P.B. 5818 Patentlaan 2
 NL - 2280 HV Rijswijk
 Tel. (+ 31-70) 340-2040, Tx. 31 651 epo nl,
 Fax: (+ 31-70) 340-3016

Authorized officer

Zanti, P

INTERNATIONAL SEARCH REPORT

International Application No.

PCT/US 94/00853

C.(Continuation) DOCUMENTS CONSIDERED TO BE RELEVANT		
Category	Citation of document, with indication, where appropriate, of the relevant passages	Relevant to claim No.
A	EP,A,0 259 906 (FORELEC) 16 March 1988 see column 2, line 4 - column 4, line 34 ---	1,8-10
A	US,A,4 617 913 (EDDINGTON) 21 October 1986 see column 1, line 5-9 see column 2, line 64 - column 4, line 41 see column 6, line 6-46 ---	1,12-14
A	EP,A,0 076 069 (HOCHMAIR) 6 April 1983 see page 4, line 5 - page 5, line 17 -----	1,8,9, 17,30

INTERNATIONAL SEARCH REPORT

Information on patent family members

International Application No

PCT/US 94/00853

Patent document cited in search report	Publication date	Patent family member(s)	Publication date
US-A-4988333	29-01-91	US-A- 5085628	04-02-92
US-A-4908509	13-03-90	NONE	
US-A-4943750	24-07-90	US-A- 4997521	05-03-91
EP-A-0259906	16-03-88	NL-A- 8602043 DE-D- 3787944 DE-T- 3787944 US-A- 4932405	01-03-88 02-12-93 17-02-94 12-06-90
US-A-4617913	21-10-86	NONE	
EP-A-0076069	06-04-83	US-A- 4419995 AU-B- 552033 AU-A- 8833382 AU-B- 558108 AU-A- 8954082 BE-A- 894422 CA-A- 1194552 WO-A- 8300999 JP-B- 3036538 JP-T- 58501535	13-12-83 22-05-86 24-03-83 15-01-87 08-04-83 17-03-83 01-10-85 31-03-83 31-05-91 16-09-83