



## INTERNATIONAL APPLICATION PUBLISHED UNDER THE PATENT COOPERATION TREATY (PCT)

<p>(51) International Patent Classification<sup>6</sup> : G01N 27/327, 31/22, C12Q 1/00</p>	<p>A1</p>	<p>(11) International Publication Number: <b>WO 95/22051</b> (43) International Publication Date: 17 August 1995 (17.08.95)</p>
<p>(21) International Application Number: PCT/US95/01500 (22) International Filing Date: 6 February 1995 (06.02.95) (30) Priority Data: 08/194,652 9 February 1994 (09.02.94) US (71) Applicant: ABBOTT LABORATORIES [US/US]; CHAD 0377/AP6D-2, 100 Abbott Park Road, Abbott Park, IL 60064-3500 (US). (72) Inventors: HANAGAN, Ted, J.; 156 West Austin, Libertyville, IL 60048 (US). SAFFORD, Lance, K.; 4116 Graceleaf Court #305, Park City, IL 60085 (US). SCHULTZ, Steven, G.; 2204 Funderburk Drive, Winthrop Harbor, IL 60096 (US). FORD, Jay, R.; 1200 E. Kensington Road, Mt. Prospect, IL 60056 (US). MARCINIEC, Edmund, T.; 1010 Sunrise Road, Libertyville, IL 60048 (US). JOHNSON, Kenneth, S.; 1170 Parker Lane, Buffalo Grove, IL 60089 (US). NORLIE, John, D., Jr.; 5388 Virginia Court, Gurnee, IL 60031 (US). (74) Agents: GORMAN, Edward, H., Jr. et al.; Abbott Laboratories, CHAD-0377/AP6D-2, 100 Abbott Park Road, Abbott Park, IL 60064-3500 (US).</p>	<p>(81) Designated States: AU, CA, JP, European patent (AT, BE, CH, DE, DK, ES, FR, GB, GR, IE, IT, LU, MC, NL, PT, SE). <b>Published</b> <i>With international search report.</i> <i>Before the expiration of the time limit for amending the claims and to be republished in the event of the receipt of amendments.</i></p>	

(54) Title: DIAGNOSTIC FLOW CELL DEVICE

(57) Abstract

The present invention provides a diagnostic flow cell for determining the presence or amount of an analyte which may be contained in a test sample. The flow cell comprises a spacing layer having a longitudinal void disposed between a pair of opposed substrates. The spacing layer and the opposed substrates define a flow channel wherein reagent means can be immobilized. When the immobilized reagent means is contacted with an analyte, the reagent means can produce an electrically, optically, or electrically and optically detectable response to the analyte. Hence, the reagent means that is immobilized within the flow channel can comprise (i) a counter electrode, a reference electrode and a working electrode, (ii) an optically sensitive dye or (iii) a counter electrode, a reference electrode and a working electrode and an optically sensitive dye. The flow cell can be interfaced with means for introducing a test sample into and out of the flow cell's flow channel and detection means for detecting a signal generated by the immobilized reagent means. The present invention also provides methods for detecting the presence or amount of an analyte which may be contained in a test sample.

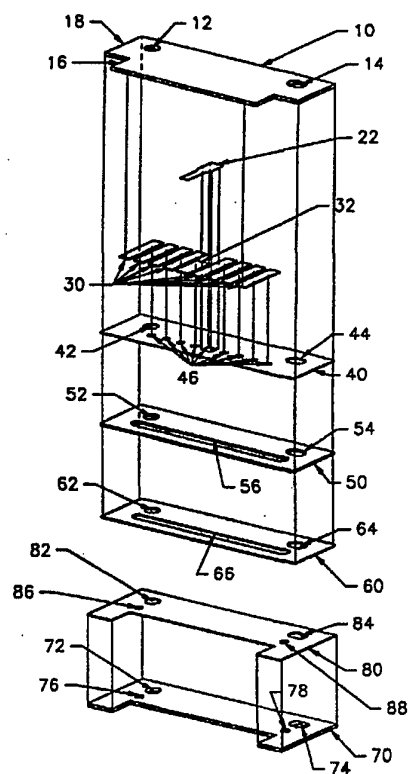

**FOR THE PURPOSES OF INFORMATION ONLY**

Codes used to identify States party to the PCT on the front pages of pamphlets publishing international applications under the PCT.

<b>AT</b>	Austria	<b>GB</b>	United Kingdom	<b>MR</b>	Mauritania
<b>AU</b>	Australia	<b>GE</b>	Georgia	<b>MW</b>	Malawi
<b>BB</b>	Barbados	<b>GN</b>	Guinea	<b>NE</b>	Niger
<b>BE</b>	Belgium	<b>GR</b>	Greece	<b>NL</b>	Netherlands
<b>BF</b>	Burkina Faso	<b>HU</b>	Hungary	<b>NO</b>	Norway
<b>BG</b>	Bulgaria	<b>IE</b>	Ireland	<b>NZ</b>	New Zealand
<b>BJ</b>	Benin	<b>IT</b>	Italy	<b>PL</b>	Poland
<b>BR</b>	Brazil	<b>JP</b>	Japan	<b>PT</b>	Portugal
<b>BY</b>	Belarus	<b>KE</b>	Kenya	<b>RO</b>	Romania
<b>CA</b>	Canada	<b>KG</b>	Kyrgystan	<b>RU</b>	Russian Federation
<b>CF</b>	Central African Republic	<b>KP</b>	Democratic People's Republic of Korea	<b>SD</b>	Sudan
<b>CG</b>	Congo	<b>KR</b>	Republic of Korea	<b>SE</b>	Sweden
<b>CH</b>	Switzerland	<b>KZ</b>	Kazakhstan	<b>SI</b>	Slovenia
<b>CI</b>	Côte d'Ivoire	<b>LI</b>	Liechtenstein	<b>SK</b>	Slovakia
<b>CM</b>	Cameroon	<b>LK</b>	Sri Lanka	<b>SN</b>	Senegal
<b>CN</b>	China	<b>LU</b>	Luxembourg	<b>TD</b>	Chad
<b>CS</b>	Czechoslovakia	<b>LV</b>	Latvia	<b>TG</b>	Togo
<b>CZ</b>	Czech Republic	<b>MC</b>	Monaco	<b>TJ</b>	Tajikistan
<b>DE</b>	Germany	<b>MD</b>	Republic of Moldova	<b>TT</b>	Trinidad and Tobago
<b>DK</b>	Denmark	<b>MG</b>	Madagascar	<b>UA</b>	Ukraine
<b>ES</b>	Spain	<b>ML</b>	Mali	<b>US</b>	United States of America
<b>FI</b>	Finland	<b>MN</b>	Mongolia	<b>UZ</b>	Uzbekistan
<b>FR</b>	France			<b>VN</b>	Viet Nam
<b>GA</b>	Gabon				

## DIAGNOSTIC FLOW CELL DEVICE

### Field of the Invention

5 The present invention relates to a flow cell device for  
detecting the presence or amount of an analyte in a test sample.  
In particular, the present invention relates to a flow cell device  
having immobilized reagent means which produce an electrically  
or optically detectable response to an analyte which may be  
contained in a test sample.

10

### Background of the Invention

Immobilized catalytically-active-molecules such as enzymes  
have been used as binding participants to determine the presence  
or amount of the immobilized enzyme's substrate that may be  
15 present in a test sample. Commercial chemistry analyzers use  
enzymes, which have been bound to porous surfaces, for the  
conversion of enzyme substrates to optically or electrochemically  
detectable products. For example, electrochemical sensors utilize  
the ability of an immobilized enzyme to form an electrochemically  
20 active molecule as a result of the action of the enzyme on its  
substrate. Such sensors employ a potentiostat and amperometric  
electrodes that typically consist of an enzyme or working electrode,  
a reference electrode and a counter electrode. The enzyme  
electrode is typically made of platinum and is supplied with an  
25 overlaying oxidase enzyme layer. When the surface of an electrode  
is immersed in a sample containing an oxidizable substrate and  
molecular oxygen, both molecules diffuse into the enzyme layer  
where the substrate reacts with the enzyme resulting in reduction  
of the enzyme. The reduced enzyme is oxidized by the molecular  
30 oxygen which, in turn, is reduced to peroxide. At a sufficiently  
high electrode potential (maintained via the reference electrode),  
the platinum portion of the enzyme electrode oxidizes the peroxide  
to regenerate oxygen and transfer two electrons to the counter  
35 electrode. The potentiostat measures the current generated by the  
transferred electrons and the amount of current is related to the  
amount of oxidizable substrate in the sample. Hence, the presence

- 2 -

and/or amount of an oxidizable substrate in the sample can be determined.

Prior to the present invention, devices which electrochemically or optically detect the presence or amount of an  
5 analyte which may be present in a test sample are generally single use disposable devices which are incapable of analyzing a plurality of circulating test samples.

#### Summary of the Invention

10 According to the present invention, a diagnostic flow cell for determining the presence or amount of an analyte in a test sample is provided. The diagnostic flow cell comprises (i) a spacing layer disposed between a first and a second opposed substrate, wherein the spacing layer has a longitudinal void and wherein the spacing  
15 layer and opposed substrates define a flow channel; (ii) fastening means for coupling the spacing layer and the opposed substrates; (iii) inlet means for permitting a sample to enter the flow channel; (iv) outlet means for permitting the sample to exit the flow channel; and (v) immobilized reagent means for producing a  
20 detectable signal, wherein the reagent means is at least partially contained within the flow channel. Using methods well known in the art, the flow cell can be interfaced with detection means for detecting a signal generated by the immobilized reagent means. Additionally, methodologies are well known in the art for placing  
25 the flow cell in fluid communication with flow means for introducing a test sample into the flow cell's flow channel.

The immobilized reagent means can comprise (i) a counter electrode, a reference electrode and a working electrode or (ii) an optically sensitive dye. Advantageously, combinations of the  
30 reagent means can be employed.

The present invention also provides methods for detecting the presence or amount of an analyte which may be contained in a test sample. According to one embodiment of the invention, the flow cell device can generate an electrically detectable response to  
35 an analyte that may be present in a test sample.

- 3 -

According to another embodiment of the invention, the assay device can generate an optically detectable response to an analyte that may be present in a test sample.

5 According to still another embodiment of the invention, the assay device can generate optically and electrochemically detectable responses to analytes which may be present in a test sample.

10 Due to the low costs associated with the manufacture of the flow cell, it can be used as a disposable assay unit. However the present invention provides an assay device that can be used for multiple assays and is thereby reusable.

#### Description of the Drawings

15 Figure 1 illustrates an expanded view of an electrochemical flow cell.

Figure 2 illustrates a partially completed electrochemical flow cell.

Figure 3 illustrates an assembled electrochemical flow cell which is interfaced with detection means.

20 Figure 4 illustrates a cross sectional view of an assembled electrochemical flow cell.

Figure 5 illustrates an expanded view of an optical flow cell.

Figure 6 illustrates an assembled optical flow cell.

25 Figure 7 illustrates a cross sectional view of an assembled optical flow cell.

Figure 8 graphically illustrates an electrochemical flow cell's working electrode response to varying concentrations of glucose.

30 Figure 9 graphically illustrates an optical flow cell's response to varying concentrations of dissolved oxygen.

- 4 -

Detailed Description of the Invention

The following definitions are applicable to the invention:

## I. DEFINITIONS

5           The term "analyte", as used herein, refers to the compound or composition to be detected or measured and which initiates the generation of a detectable response. Analytes include, but are not intended to be limited to, enzymes or enzyme substrates, metal ions, blood gases, toxins, organic compounds, proteins, peptides,  
10 amino acids, carbohydrates, nucleic acids, hormones, steroids, vitamins, drugs (including those administered for therapeutic purposes as well as those administered for illicit purposes), and metabolites of any of the above substances. For example, such analytes include, but are not intended to be limited to, alanine  
15 aminotransferase (ALT), aspartate aminotransferase (AST), creatinine kinase (CK), creatinine kinase MB (CK-MB), lactate dehydrogenase (LDH), gamma glutamyl transpeptidase (GGTP), alkaline phosphatase, glucose, fructose, galactose, sucrose, lactose, lactate, cholesterol, urea, creatinine, triglycerides, uric  
20 acid, bilirubin, glutamate, potassium, sodium, chloride, calcium, magnesium, lithium, oxygen, carbon dioxide, hydrogen ions (pH), hemoglobin, glycated hemoglobin (Gly. Hb), C-reactive protein, serum lipoproteins, serum albumin, deoxyribonucleic acid (DNA), ribonucleic acid (RNA), bile acids, salicylates, acetaminophen,  
25 theophylline, phenytoin and the like.

          The term "test sample", as used herein, refers to a material suspected of containing the analyte. The test sample can be used directly as obtained from the source or following a pre-treatment to modify the character of the sample. The test sample can be derived  
30 from any biological source, such as a physiological fluid, including, blood, saliva, ocular lens fluid, cerebral spinal fluid, sweat, urine, milk, ascites fluid, mucous, synovial fluid, peritoneal fluid, amniotic fluid and the like, and fermentation broths cell cultures, and chemical reaction mixtures and the like.  
35 The test sample can be pretreated prior to use, such as preparing plasma from blood, diluting viscous fluids, and the like. Methods

- 5 -

of treatment can involve filtration, distillation, concentration, inactivation of interfering components, and the addition of reagents. In addition to biological or physiological fluids, other liquid samples can be used such as water, food products and the like for the performance of environmental or food production assays. In addition, a solid material suspected of containing the analyte can be used as the test sample. In some instances, it may be beneficial to modify a solid test sample to form a liquid medium or to release the analyte.

10

## II. FLOW CELLS

The present invention is directed to a diagnostic flow cell comprising two opposed substrate layers and a spacing or gasket layer disposed between the two opposed substrate layers. The spacing or gasket layer has a longitudinal void which, in combination with the substrates, defines the flow cell's flow channel. A substrate layer, or the substrate layers, can be supplied with apertures which, when the flow cell is assembled, can serve as inlet and outlet means for introducing sample into the flow channel and allowing sample to exit the flow channel. Preferably, the apertures are supplied to one substrate and are located near the ends of the flow channel defined by the substrates and the spacing layer.

Reagent means that can generate a detectable signal when contacted with an analyte can be immobilized on a substrate or the substrates. Typically, the immobilized reagent means is substantially insoluble. Consequently, the reagent means can be contacted with multiple test samples thereby making the flow cell reusable. Depending upon the analyte to be detected, the opposed substrates can have a single or multiple reagent means immobilized thereon. Thus, by immobilizing the appropriate reagent means, a single flow cell can, for example, electrically and optically detect analytes which may be present in a test sample. Additionally, by immobilizing a multiplicity of the same reagent means to a substrate or the substrates, a single flow cell can detect the presence or amount of an analyte in replicates.

- 6 -

The various layers that can comprise the flow cell herein provided can be applied to the opposed substrates, and the substrates can then be coupled with a gasket layer to thereby form the flow cell taught herein. Due to the design of the flow cell and the manner in which it can be manufactured, the diagnostic flow cell is reusable, inexpensive to produce, easily stored in a complete or incomplete form, capable of being patterned with immobilized reagent means, and, as compared to previous technology, the number of machined parts is greatly reduced. Moreover, signal to noise ratios which are generated by the reagent means are increased and electromagnetic interferences are reduced.

The opposed substrates can be made of any chemically inert, non-conductive and physically durable material which is capable of supporting the various materials applied thereon. Examples of such materials include, but are not intended to be limited to film plastics such as polyester, polycarbonate, polystyrene, polyetherimide, and the like; molded plastics such as acrylic, phenolic, polyolefin, and the like; ceramics such as alumina ( $\text{Al}_2\text{O}_3$ ), zirconia ( $\text{ZrO}_2$ ), magnesia ( $\text{MgO}$ ), and the like; glass; silicon wafers; and the like; preferably the substrate material comprises a polyester film.

The spacing or gasket layer materials are typically chemically and electrochemically inert as well as substantially non-absorbent and impervious to water. Examples of materials that have these properties include, but are not intended to be limited to printing inks, painted inks, sprayed inks, latexes, urethanes, vinyls, polyesters, film plastics and the like, preferably the spacing layer comprises a dielectric printing ink. The thickness of the flow cell's spacing layer is largely responsible for the volume of the flow channel. Thus, for example, when it is desirable to have large amounts of sample contained within the flow channel, the thickness of the spacing layer can be increased. The amount of sample contained in the flow channel, in relation to the exposed substrate surface area, is preferably in the range of between about  $1.0 \mu\text{l}/\text{cm}^2$  and about  $500 \mu\text{l}/\text{cm}^2$ , more preferably



- 7 -

between about 2  $\mu\text{l}/\text{cm}^2$  and about 250  $\mu\text{l}/\text{cm}^2$  and most preferably between about 2.5  $\mu\text{l}/\text{cm}^2$  and about 100  $\mu\text{l}/\text{cm}^2$ .

The diagnostic flow cell can further comprise a mask layer immobilized between the two substrate layers. Similarly to the  
5 spacing layer, the mask layer is typically chemically and electrochemically inert as well as non-absorbent and impervious to water. Examples of suitable mask layer materials have been described with reference to the spacing layer. When multiple  
10 analytes are to be detected, or replicates of the same analyte are to be detected, the mask layer is particularly preferred and serves as a barrier between the various immobilized reagent means.

The opposed substrates, and the various layers that can be disposed between the substrates, can be secured or coupled to one another to form a flow cell using fastening means such as, for  
15 example, lamination, solvent bonding, nuts and bolts, rivets and the like, preferably an adhesive layer secures the substrates, and the various layers thereon, to each other. An adhesive layer is preferably inert chemically and electrochemically as well as being capable of retaining its adherent quality in saline solutions.  
20 Examples of such materials include, but are not limited to ultraviolet cured pressure sensitive adhesives, heat cured pressure sensitive adhesives, vinyl based pressure sensitive adhesives, and the like, preferably a polyurethane based ultravioletly cured adhesive.

25

#### A. ELECTROCHEMICAL FLOW CELLS

In the case where the diagnostic flow cell is capable of electrochemically detecting an analyte that may be contained in a test sample, the substrates can have reagent means immobilized  
30 thereon which form a reference electrode, a counter electrode and a working electrode. The reference electrode can comprise (i) a material or a combination of materials capable of stabilizing a test sample's potential or otherwise providing a constant potential within a test solution; and (ii) a conductive trace material which is  
35 capable of being interfaced with a detection means and which is substantially inert at the assay device's operating potential.

- 8 -

Materials capable of developing a stable potential include oxidation/reduction pairs (variably referred to as "redox couples") including, but not intended to be limited to, silver/silver chloride/graphite blends, mercury/mercurous chloride blends, 5 silver/silver iodide blends and the like, preferably silver/silver chloride blends which can be dispensed using screen printing techniques. Examples of materials that can be used as conductive trace material include, but are not intended to be limited to gold, carbon, nickel, silver, palladium, ruthenium, rhodium, tin oxide, 10 indium tin oxide and the like, preferably carbon that has been dispersed in a screen printing ink.

The counter electrode can comprise an electrochemically conductive material which is relatively inert at the assay device's operating potential. Examples of materials having these 15 properties include, but are not intended to be limited to gold, carbon, nickel, silver, palladium, ruthenium, rhodium, tin oxide, indium tin oxide and the like, preferably carbon that has been dispersed in a screen printing ink.

The working electrode can comprise (i) a conductive trace 20 material and ii) an enzyme or enzymes immobilized to or in contact with the conductive trace. Preferably, the enzyme is immobilized on the conductive trace such that when the flow cell is assembled, the enzyme will remain efficacious for multiple uses. A particularly preferred method of immobilizing an enzyme to the 25 conductive trace material employs an immobilization medium disclosed in co-owned and co-pending application Serial No. \_\_\_\_\_ (Atty Docket No. 5488.US.01), entitled BIOREAGENT IMMOBILIZATION MEDIUM, filed on even date herewith and incorporated herein by reference.

30 The bioreagent immobilization medium comprises i) an enzyme which is immobilized to a solid phase and ii) a binding reagent comprising a latex resin, wherein the immobilized enzyme is evenly dispersed. The binding reagent may also include optional ingredients which enhance the immobilization medium's 35 chemical and physical properties. The enzyme can be immobilized to the solid phase by methods well known in the art such as, for

- 9 -

example, covalent, ionic or adsorptive bonding of the enzyme to the solid phase. By way of example and not of limitation, the various enzymes, solid phases, resins and optional ingredients that can be employed in the bioreagent immobilization medium can be found  
5 below in Table 1.

Table 1

ENZYMES	SOLID PHASES	RESINS	OPTIONAL INGREDIENTS
glucose oxidase, glutamate oxidase, lactate oxidase, glycerol phosphate oxidase, cholesterol oxidase, cholesterol esterase, lipase, glycerol kinase, glutamate dehydrogenase, creatinine deaminase, and uricase	agarose and derivatives thereof, polyacrylamide and derivatives thereof, silicas, aluminosilicates, aluminum oxides, carbon or graphite particles, and platinum group metal oxides	acrylic latex, styrene acrylic latexes, vinyl acetate latex and polyurethane latex	plasticizers, film forming agents, thickeners, stabilizers, dispersing agents, and defoaming agents

10 In order to allow easy interface with detection means for detecting a signal generated by the immobilized reagent means, it is preferred that a portion of the immobilized reagent means is contained within the flow channel and a portion of the immobilized reagent means extends out of the flow cell's flow channel.

15 It will be understood, of course, that the present invention is not limited to flow cells having three electrode systems, and that two electrode systems are contemplated. For example, a two

- 10 -

electrode configuration can comprise a working electrode and a combination reference/counter electrode.

#### B. OPTICAL FLOW CELLS

5 In cases where the diagnostic flow cell optically detects the presence or amount of an analyte which may be contained in a test sample, the immobilized reagent means generates an optically detectable signal when it is contacted with an analyte which may be contained in a test sample. The immobilized reagent means  
10 that can be used in optically based flow cells are generally compounds or mixtures of compounds that, when contacted with an analyte, emit a signal which is optically detectable. Examples of such immobilized reagent means include, but are not intended to be limited to pH sensitive dyes; oxygen sensitive dyes; dyes or  
15 chelating agents which are sensitive to ions such as calcium and magnesium ions; and the like; preferably platinum tetra(pentafluorophenyl)porphyrin which is an oxygen sensitive dye that changes its fluorescence lifetime in the presence of dissolved oxygen. Such an optically sensitive dye is disclosed in  
20 U.S. Pat. No. 4,810,655 and U.S. Pat. No. 5,043,286 both of which are herein incorporated by reference.

Optical flow cell devices preferably have the immobilized reagent means entirely contained within the flow cell's flow channel, and such a flow cell is configured to be interfaced with a  
25 detection means using optical fibers, optical wave guides, incident beams of light, and the like.

#### C. MULTIPLE APPLICATION FLOW CELLS

As it will be understood by one skilled in the art, multiple  
30 reagent means can be immobilized to the substrate or substrates. Consequently, a single flow cell can optically and electrochemically detect the presence or amount of an analyte or multiple analytes which may be contained in a test sample.

- 11 -

## III. FLOW CELL PRODUCTION

The flow cell can be manufactured by layering the opposed substrates with the various layers that may comprise the cell. The various layers applied to the opposed substrates are largely  
5 dependent upon the type of flow cell desired (i.e.. electrochemical, optical or combination electrochemical and optical). After the various layers have been applied, the substrates can be coupled to each other to form the flow cell which then can be interfaced with detection means for detecting a signal generated by the  
10 immobilized reagent means and flow means for introducing sample into the flow cell's flow channel. The substrates can be layered with the various layers described herein using any means capable of applying a consistently thick layer. Examples of such means include, but are not intended to be limited to stenciling,  
15 spray painting, tampo printing, photolithography, and the like, preferably screen printing. For example, in the case of an electrochemical flow cell, it has been found advantageous to screen print the following successive layers to one substrate: a reference electrode, a working electrode, a mask layer, a spacing layer and  
20 an adhesive layer; while applying a counter electrode layer to a second substrate. The two substrates and their respective layers can then be, for example, laminated to each other to form the flow cell. It will be understood, of course, that many variations, in terms of the possible order of layers and combinations of layers,  
25 are possible.

Advantageously, the flow cell can be mass produced by layering, for example, sheets or rolls of substrate material with the various layers described herein. The sheets or rolls of layered substrate can be stored at any of the stages of the layering process.  
30 For example, in the case of an electrochemical flow cell, sheets of substrate material can be layered with a reference electrode and a working electrode and stored before subsequent layers, for example a mask layer and an adhesive layer, are applied thereon. After all of the desired layers have been applied to the substrate material,  
35 they can be, for example, cut from the rolls or sheets of substrate

- 12 -

material and assembled to form the diagnostic flow cell herein provided.

#### IV. DETECTION MEANS

5           Detection means for detecting an electrochemical response to the presence of an analyte that may be contained in a test sample include, but are not intended to be limited to potentiostats, potentiometers, and the like. Such detection means can be placed in communication with the flow cell using methodologies well  
10 known in the art. For example, an electrochemical flow cell can be placed in communication, or interfaced, with the detection means using electrical connectors such as wires and clamps.

          Detection means for detecting an optical response to the presence of an analyte that may be contained in a test sample  
15 include, but are not intended to be limited to luminometers, spectrophotometers, and the like. Such detection means can be interfaced with suitable detection means using methodologies well known in the art. For example, an optically based flow cell can be interfaced with detection means using fiber optic cables.

20           It will be understood, of course, that the detection means employed is largely dependent upon the analyte being detected and therefore, the immobilized reagent means employed. It will also be understood that multiple detection means can be interfaced with the flow cell.

25

#### V. FLOW MEANS

          Additionally, it will be obvious to one of skill in the art, that the flow cell can be connected to flow means which can transport samples into and out of the flow cell's flow channel. Examples of  
30 suitable flow means include, but are not intended to be limited to syringes, syringe pumps, reciprocating pumps, diaphragm pumps, pressure or vacuum sources and the like, preferably peristaltic pumps.

## VI. EMBODIMENTS

While many types of devices fall within the scope of the present invention, particularly preferred embodiments will be described in conjunction with the drawings. Referring now to the drawings, Figure 1 shows an expanded view of an electrochemical flow cell. Figure 1 shows substrate **10** and the several layers that can be applied thereon to form one part of an electrochemical flow cell. Specifically, the layers that can be applied to the substrate **10** include: the reference electrode including redox couple **22** and conductive trace **32**; the conductive traces **30** which form part of the working electrodes; a mask layer **40**; a spacing layer **50**; and an adhesive layer **60**. Figure 1 also shows a second substrate **70** and a counter electrode **80** which can be layered on substrate **70** to form the other half of an electrochemical flow cell. To assist in coupling the substrates to form the electrochemical flow cell, opposed substrates **10** and **70** are provided with alignment apertures **12** and **14**, and **72** and **74**; the mask layer **40** is provided with alignment apertures **42** and **44**; the spacing layer is provided with alignment apertures **52** and **54**; the adhesive layer is provided with alignment apertures **62** and **64**; and the counter electrode is provided with alignment apertures **82** and **84**.

Adhesive layer **60** and spacing layer **50** are supplied with longitudinal voids **66** and **56** which partially define the flow cell's flow channel when the adhesive and spacing layers are sandwiched between substrates **10** and **70**. Substrate **70** and counter electrode layer **80** are supplied with port apertures **76**, **78**, **86** and **88**. When the substrates, and their respective layers, are assembled or coupled to each other, the port apertures align near the ends of the longitudinal voids **56** and **66**, and serve as inlet and outlet ports for the flow channel.

As seen best in Figure 1, mask layer **40** is supplied with a plurality of apertures **46** equal to the number of conductive traces. When the flow cell is assembled, these apertures allow portions of the conductive traces **30** and redox couple **22** to remain exposed. Prior to coupling the substrates, an enzyme can be immobilized on

- 14 -

the exposed portions of the conductive traces **30** to complete the working electrodes.

Figure 2 shows substrate **10** with the layers comprising the reference electrode (**22** and **32**) and the conductive traces **30**  
5 immobilized thereon. A portion of the redox couple **22** is exposed such that when the flow cell is assembled and a test sample is contained within the flow channel, the exposed portion of the redox couple can contact the test sample and maintain its potential.

Figure 3 shows an assembled electrochemical flow cell  
10 which is interfaced with potentiostat **400**. As shown in Figure 3, the flow cell is interfaced with the potentiostat via a series of electrical connections leading from the counter electrode, working electrodes and reference electrode to the potentiostat. Specifically, connections **330** and wires **340** interface the counter electrode and  
15 the potentiostat, connections **350** and wires **360** interface the working electrodes and the potentiostat, and connection **380** and wire **370** interface the reference electrode and the potentiostat. All connections are made with the conductive traces comprising the various electrodes.

20 Figure 3 also shows a complete working electrode comprising immobilized enzyme **100** and conductive trace **30**. Additionally inlet and outlet ports **300** and **310** are shown near the ends of flow channel **320**.

Figure 4 shows a cross-sectional view of an electrochemical  
25 flow cell as taken through segment A-A of Figure 3. As shown from that view, several of the layers which can form an assembled electrochemical flow cell can be seen. Included in the layers observable from this view are the substrates **10** and **70**; redox couple **22**; the working electrode including conductive traces **30**  
30 and the enzyme immobilized thereon **100**; and the counter electrode **80**. The flow channel **320** is also illustrated by Figure 4.

The various layers that can comprise an optical flow cell can be seen best in Figure 5. Figure 5 shows two substrate layers **110** and **140** and the layers that can be placed therebetween. Substrate  
35 **110** is supplied with apertures **112** which, when the flow cell is assembled, are located near the ends of longitudinal voids **122** and



- 15 -

132, and serve as inlet and outlet ports for the assembled optical flow cell's flow channel. Adhesive layer 120 is shown between substrate 110 and spacing layer 130 but would be equally effective between substrate 140 and spacing layer 130. The adhesive layer  
5 120 and the spacing layer 130 have longitudinal voids, 122 and 132, respectively which help define the flow cell's flow channel when sandwiched between substrates 110 and 140. Also shown in Figure 5 are a plurality of dye spots 142 which are immobilized on substrate 140. The substrates 110 and 140, the adhesive layer 120  
10 and the spacing layer 130 are also supplied with alignment apertures 114, 144, 124 and 134 which assist in aligning the flow cell during assembly.

Figure 6 illustrates an assembled optical flow cell including substrate 110; dye spots 142; and apertures 112 which serve as inlet  
15 and outlet ports for the flow channel 150.

Figure 7 shows a cross sectional view, as taken through section B-B of Figure 6, of an optical flow cell that is interfaced with detection means 500. As shown by Figure 7, the dye spots 142 are contained in the flow channel 150 which is defined by substrates  
20 110 and 140; and the longitudinal void in the spacing layer (not observable from this perspective). As shown in Figure 7, the detection means 500 can comprise a light source 510, a light detector 520 and a intensity reader 530.

## 25 VII. ASSAY METHODS

The flow cell device can be used to detect the presence or amount of an analyte which may be present in a test sample. A test sample can be introduced into the flow cell's flow channel wherein it contacts the immobilized reagent means. The presence  
30 or amount of the analyte can be determined as a result of the analyte contacting the immobilized reagent means. When contacted with the test sample, the immobilized reagent means generates a detectable signal that is detected by detection means and is indicative of the presence or amount of analyte that may be  
35 contained in the test sample. It will be understood, of course, that the test sample can be, for example, introduced into the flow cell's

- 16 -

flow channel and stopped therein, it can be continuously flowed through the flow channel or it can be recirculated through the flow channel.

5 The following examples are not intended to limit the invention herein provided but are intended to illustrate the invention.

### Example 1

#### Production of an Bioreagent Immobilization Medium Using 10 Glucose Oxidase Adsorbed to Platinized Carbon

The enzyme binding resin (see below) was selected from the commercial paint industry formulations designed to be fast drying, adherent and able to emulsify pigments. The mixing procedure was designed to generate high shear rates, thus  
15 producing a very highly dispersed pigment and small particle size. In order to obtain this smooth emulsion, the formulation components were mixed in a WIG-L-BUG (Crescent Dental Manufacturing, Lyons, IL) which is a device designed to mix dental amalgams. The mixer mechanically agitates the  
20 formulation in a 2 ml stainless steel vial containing a ball bearing, thus allowing 0.5 to 1 ml coating preparations to be blended.

#### Materials

1. Platinized Vulcan XC 72 (carbon black) containing 10%  
25 platinum
2. Glucose Oxidase (GOD: Grade I from *Aspergillus niger*,  
Boehringer Mannheim Biochemicals, Indianapolis, IN)
3. Phosphate Buffered Saline (PBS: 100 mM sodium Phosphate,  
100 mM NaCl, pH 6.0)
- 30 4. Acrylic resin mix (31.6% non-volatile solids formulated as  
shown below)

- 17 -

<u>Acrylic Resin Mix Component</u>		<u>% by</u>
<u>weight</u>		
	Joncryl 537 acrylic emulsion (Johnson Wax, Racine, WI)	54
	Joncryl 56 acrylic resin (Johnson Wax, Racine, WI)	27
5	DMAMP 80 (Angus Chemical Co., Northbrook, IL)	1
	Ektasolve EP ( Eastman Chemicals, Kingsport, TN)	9
	Distilled water	9

Procedure

- 10 Enzyme was adsorbed to platinized carbon by adding a solution of GOD in PBS buffer to suspensions of platinized carbon in PBS buffer. One suspension contained 101 mg of platinized carbon in 0.44 ml of PBS plus 0.2 ml of a 50 mg/ml solution of GOD, while the other suspension contained 51 mg of platinized carbon in
- 15 0.2 ml of PBS plus 0.1 ml of a 50 mg/ml solution of GOD. The mixtures were allowed to statically incubate for 1.5 hours at an ambient temperature before they were centrifuged at 2000 rpm. The supernatants were discarded and the resulting wet GOD/carbon pellets were resuspended in 0.8 gm of the resin mix
- 20 and blended in a WIG-L-BUG for 10 minutes. A WIG-L-BUG (Crescent Dental Manufacturing, Lyons, IL) is a device designed to mix dental amalgams. The mixer mechanically agitates the formulation in a 2 ml stainless steel vial containing a ball bearing, thus allowing 0.5 to 1 ml coating preparations to be blended. The
- 25 resulting coating solutions were hand dispensed onto separate electrodes and tested electrochemically. The formulation for the coating solution is shown below in Table 2.

Table 2

Formula	mg carbon	mg Resin Mix	mg Resin Solids	Resin solids/ Carbon ratio
1	101	800	253	2.50

- 18 -

Example 2  
Electrochemical Flow Cell

Materials:

- 5       1. ICI ST505 Heat Stabilized Polyester Film (Tekra Corporation, Milwaukee, WI)
2. Acheson SS24950 Silver/Silver Chloride Ink (Acheson Colloids, Port Huron, MI)
3. Acheson 423SS Carbon Ink (Acheson Colloids, Port Huron, MI)
- 10       4. Acheson ML25198 Insulating Dielectric (Acheson Colloids, Port Huron, MI)
5. Acheson UV 8002 Adhesive (Acheson Colloids, Port Huron, MI)
- 15       6. Bioreagent Immobilization Medium (from Example 1)
7. Potentiostat - an eight channel potentiostat was assembled at Abbott Laboratories (Abbott Park, IL) to accommodate the flow cell described herein

20   Manufacturing Procedure:

A 0.007 inch thick polyester film was used as substrate support material for both halves of the flow cell. A working electrode, reference electrode, mask layer, spacing layer and adhesive were applied to one substrate and a counter electrode was applied to the other substrate. The manufacturing process will be explained with references to Figure 1. A layer of silver/silver chloride ink **22** was screen printed in a pattern to form the redox couple portion of a single reference electrode. Next, a layer of carbon ink was screen printed on the redox couple and substrate in a pattern to form eight working electrode conductive traces **30** and the conductive trace portion **32** of the reference electrode. The redox couple layer and conductive trace layers were printed with quantities of the respective materials that were sufficient to provide an end to end resistance of less than 100 ohms.

35       On top of both the silver/silver chloride ink and carbon ink layers a layer of dielectric **40** was screen printed in a pattern to

- 19 -

mask all of the working conductive traces **30** and redox couple **22** except for a small circular area **46** which was 0.066 inches in diameter. The masking layer of dielectric was applied in a quantity sufficient to become water impermeable. A layer of dielectric was then applied to the mask layer in a pattern to form the spacing layer **50** having longitudinal void **56**. The spacing layer of dielectric was applied using a quantity sufficient to give the flow cell's flow channel a 10  $\mu\text{l}/\text{cm}^2$  volume. A 0.001 inch layer of adhesive **60** was then printed on top of the spacing layer. The adhesive layer also had longitudinal void **66**. A paper release liner was added to the surface of the adhesive to protect it during handling. A steel ruled dye was then used to cut this part of the device from the sheet of polyester film. A steel ruled dye was also used to simultaneously cut alignment apertures **12**, **14**, **42**, **44**, **52**, **54**, **62** and **64** from all layers printed on the polyester film.

Again, with reference to Figure 1, the second substrate of the flow cell was prepared by screen printing a layer of carbon ink **80** (counter electrode) onto a sheet of polyester film. The quantity of carbon ink used was sufficient to provide an end to end resistance of less than 100 ohms. The outline of this part of the flow cell, the alignment apertures and the fluid inlet and outlet ports were cut from the sheet of polyester film with a steel-ruled die.

After the substrates and the layers immobilized thereon were cut from the polyester film, 0.35  $\mu\text{l}$  of bioreagent immobilization medium (from Example 1) was dispensed onto the circular area of the eight working electrode traces **30**. The bioreagent was allowed to cure at room temperature for one hour. Using a jig and alignment pins, the two substrates were aligned and laminated together.

30

#### Testing Procedure:

The testing procedure will be described with reference to Figure 3. The assembled flow cell was placed on a stand and connected to a peristaltic pump (not shown) via fluid connections to the inlet and outlet ports **300** and **310**. Electrical connections (between the flow cell and potentiostat **400**) to all eight of the

35

- 20 -

working electrodes 30, the counter electrode (not shown) and the reference electrode 54 were made using clamps and wires 350 and 360; 330 and 340; and 360 and 370 respectively. Liquids were drawn through the cell with a peristaltic pump and the potential of the electrodes relative to one another was controlled by a three electrode potentiostat with eight separate current monitoring channels.

The working electrode potential was set at 350mV versus the on board Ag/AgCl reference electrode. Solutions of differing glucose concentrations were then successively drawn through the cell and the current which passed at each of the eight working electrodes was monitored and recorded. The graph shown in Figure 8 illustrates the current response of one of the working electrodes to 0 mM, 2.5 mM, 6.5 mM and 11.4 mM glucose solutions in pH 7.5 aqueous phosphate buffer (PBS - 40.5 mM Na<sub>2</sub>HPO<sub>4</sub>, 9.5 mM NaH<sub>2</sub>PO<sub>4</sub>, 50 mM NaCl). Also shown in Figure 8 is the linear regression through the four data points.

As shown by Figure 8 the electrode response varies linearly with the glucose concentration in the test sample.

20

### Example 3

#### Preparation of an Oxygen Sensitive Dye

Free base tetra(pentafluorophenyl)porphyrin [H<sub>2</sub>(TFPP)] was made by adding 2.0 ml of pentafluorobenzaldehyde, 1.5 ml pyrole and 2.0 ml of boron trifluoride etherate to 1500 ml dichloromethane to form a reaction mixture. All materials comprising the reaction mixture are available from Aldrich Chemical Co., Inc., Milwaukee, WI. The reaction mixture was stirred for 1 hour before 2.5 grams of 2,3-dichloro-5,6-dicyano-1,4-benzoquinone (Sigma, ST. Louis, MO) was added and the resulting mixture was heated to 40°C for 1 hour. Then, the solvent was flash dried and the crude solid H<sub>2</sub>(TFPP) product was chromatographed over silica gel using dichloromethane as the eluting solvent. 1.0 gram of the purified H<sub>2</sub>(TFPP) and a 10 times molar excess of PtCl<sub>2</sub> (Aldrich Chemical Co.Inc.) were refluxed for 24 hours in 500 ml of

35

- 21 -

benzonitrile to synthesize crude platinum  
tetra(pentafluorophenyl)porphyrin [Pt(TFPP)]. The product was  
purified on a neutral alumina column using CH<sub>2</sub>Cl<sub>2</sub> as the eluant.  
An oxygen sensitive dye solution was prepared by dissolving 100  
5 mg of the purified Pt(TFPP) in a 25 ml of a silicone polymer stock  
solution. The polymer stock solution was made by dissolving 10.0  
grams of a dimethylsiloxane-bisphenol (General Electric Inc.,  
Waterford, NY) in 100 ml tetrahydrofuran.

10

Example 4  
Optical Flow Cell

Materials:

1. ICI ST505 Heat Stabilized Polyester Film (Tekra  
15 Corporation, Milwaukee, WI)
2. Acheson ML25198 Insulating Dielectric (Acheson Colloids,  
Port Huron, MI)
3. Acheson SU459 Adhesive (Acheson Colloids, Port Huron,  
MI)
- 20 4. Platinum tetra(pentafluorophenyl)porphyrin from Example  
3.

Manufacturing Procedure:

The manufacturing procedure will be described with  
25 reference to Figure 5. A layer of dielectric ink 130 was screen  
printed onto a substrate 140, which comprised a sheet of polyester  
film, to form the spacing layer of the flow cell. The spacing layer of  
dielectric was applied using a quantity sufficient to give the flow  
cell's flow channel a 10  $\mu\text{l}/\text{cm}^2$  volume. A .001 inch layer of  
30 adhesive 120 was then screen printed on top of the dielectric layer  
in the pattern shown in Figure 5. A release liner was then applied  
onto the surface of the adhesive to protect it during handling. The  
outline of the cell and alignment apertures 114, 134 and 144 were  
then cut from the polyester sheet using a steel-ruled die. The other  
35 substrate was formed by cutting the cell outline, alignment

- 22 -

apertures 114 and inlet and outlet ports 112 from a 0.007 inch thick sheet of polyester film.

After removing the release liner, 1.0  $\mu$ l aliquots of the oxygen sensitive dye 142 (from Example 3) were then applied to substrate 140 such that the dye spots were aligned within the longitudinal voids 122 and 132. The dye was allowed to dry for one hour at room temperature and the polyester substrates were then positioned using an alignment jig and alignment pins before being laminated together.

5  
10

Testing Procedure:

The assembled flow cell was fixed on a stand and fluid tubes were connected to the inlet and outlet ports. Tonometered solutions were then moved into and out of the cell using a peristaltic pump. Tests were performed by positioning a 250  $\mu$ m optical fiber (Ensign-Bickford Optics Co.; Avon, CT) above the dye spots 142 and illuminating the dye with light emitted from a pulsed light emitting diode (Hewlet Packard Co., Cupertino, CA) while a solution of tonometered oxygen buffer was flowing through the flow channel. Using an avalanche photodetector (Hamamatsu Corp., Bridgewater, NJ), phosphorescent intensity measurements were recorded in 2 time regions (3-17  $\mu$ seconds and 3-200  $\mu$ seconds) after each excitation pulse. The phosphorescent intensity ratio was calculated and plotted as a function of oxygen concentration.

15  
20  
25

As shown by Figure 9, a reproducible non-linear relationship between the intensity ratio and oxygen partial pressure is observed.



- 23 -

Claims

What is claimed is:

1. A diagnostic flow cell for determining the presence or amount of an analyte in a test sample, said flow cell comprises:
  - 5 i) a spacing layer disposed between a first and a second opposed substrate, wherein said spacing layer has a longitudinal void and wherein said spacing layer and said opposed substrates define a flow channel;
  - 10 ii) fastening means for coupling said spacing layer and said opposed substrates;
  - iii) inlet means for permitting said sample to enter said flow channel;
  - iv) outlet means for permitting said sample to exit said flow channel; and
  - 15 iv) immobilized reagent means for producing a detectable signal, wherein said reagent means is at least partially contained within said flow channel.
2. The flow cell of claim 1 further comprising a mask  
20 layer disposed between said substrates.
3. The flow cell of claim 1 wherein said fastening means is selected from the group consisting of a rivet, a nut and a bolt, a sonic weld and an adhesive.  
25
4. The flow cell of claim 1 wherein said reagent means comprises a reference electrode, a counter electrode and a working electrode.
- 30 5. The flow cell of claim 4 wherein said reference electrode comprises:
  - (a) a redox couple selected from the group consisting of silver/silver chloride/graphite, mercury/mercurous chloride, silver/silver iodide and silver/silver chloride; and
  - 35 (b) a conductive trace comprising graphite and screen printed ink.

- 24 -

6. The flow cell of claim 4 wherein said counter electrode comprises graphite and screen printed ink.

5 7. The flow cell of claim 4 wherein said working electrode comprises a conductive trace and an enzyme immobilized to said trace.

8. The flow cell of claim 7 wherein said enzyme  
10 comprises a bioreagent immobilization medium.

9. The flow cell of claim 1 wherein said reagent means comprises an optically active dye selected from the group consisting of a pH sensitive dye, an oxygen sensitive dye and an ion  
15 sensitive dye.

10. The flow cell of Claim 4 wherein said reagent means further comprises an optically active dye selected from the group consisting of a pH sensitive dye, an oxygen sensitive dye and an ion  
20 sensitive dye.

11. The flow cell of claim 1 wherein said flow cell further comprises flow means for introducing said test sample into said flow channel wherein said flow means is interfaced with said inlet  
25 and outlet means; and detection means for detecting a detectable signal wherein said detection means is interfaced with said immobilized reagent means.

12. A method of determining the presence or amount of  
30 an analyte in a test sample, said method comprising the steps of:

I) contacting an assay device with said test sample, wherein said assay device comprises

a) a flow cell wherein said flow cell comprises

i) a spacing layer disposed between a first  
35 and a second opposed substrate, wherein said spacing layer has a longitudinal void

- 25 -

and wherein said spacing layer and said opposed substrates define a flow channel,

- 5                   ii) fastening means for coupling said spacing layer and said opposed substrates,
- iii) inlet means for permitting said sample to enter said flow channel,
- iv) outlet means for permitting said sample to exit said flow channel, and
- 10                  iv) immobilized reagent means for producing a detectable signal, wherein said reagent means is at least partially contained within said flow channel,
- b) detection means for detecting said detectable signal wherein said detection means is interfaced with said immobilized reagent means, and
- 15                  c) flow means for introducing said test sample into said flow channel wherein said flow means is interfaced with said inlet and outlet means;
- 20                  and
- II) detecting said measurable signal.

13. The method of claim 12 further comprising a mask layer disposed between said substrates.

25

14. The method of claim 12 wherein said reagent means comprises a reference electrode, a counter electrode and a working electrode.

30                  15. The flow cell of claim 14 wherein said reference electrode comprises:

- (a) a redox couple selected from the group consisting of silver/silver chloride/graphite, mercury/mercurous chloride, silver/silver iodide and silver/silver chloride; and
- 35                  (b) a conductive trace comprising graphite and screen printed ink.

- 26 -

16. The method of claim 14 wherein said counter electrode comprises graphite and screen printed ink.

5 17. The method of claim 14, wherein said working electrode comprises a conductive trace and a bioreagent immobilization medium.

10 18. The method of claim 12 wherein said reagent means comprises an optically active dye selected from the group consisting of a pH sensitive dye, an oxygen sensitive dye, and an ion sensitive dye.

15 19. The method of claim 14 wherein said reagent means further comprises an optically active dye.

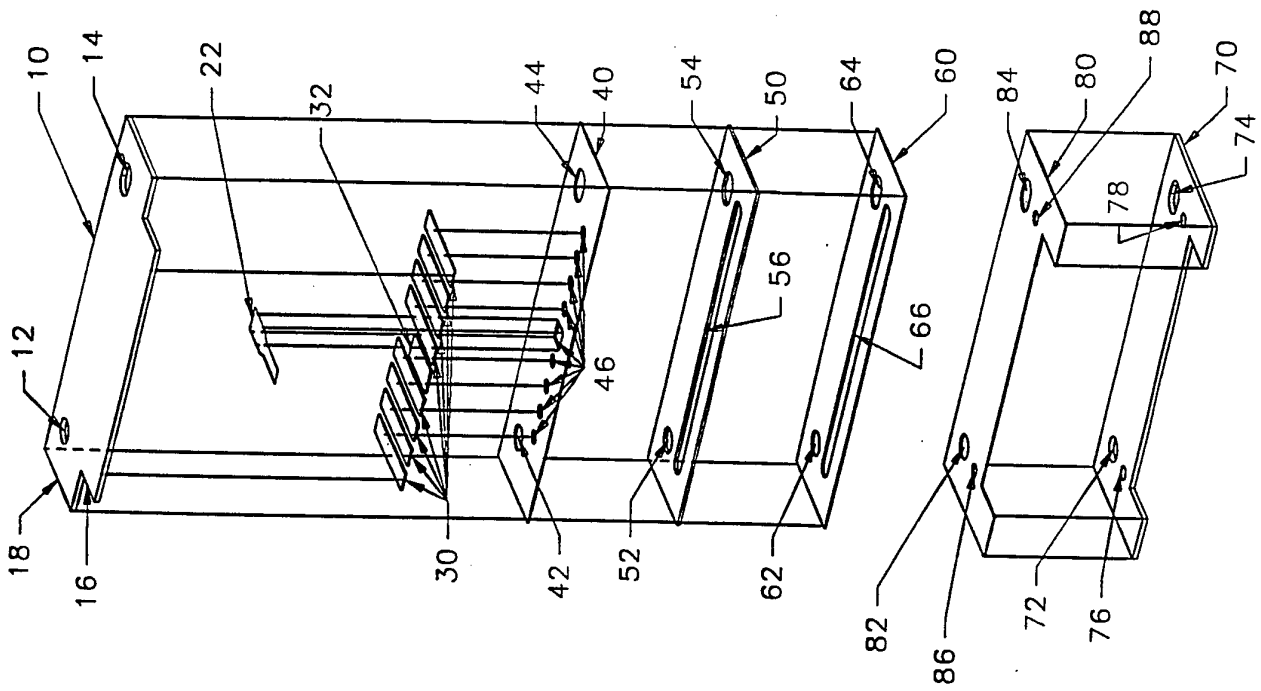

Figure 1

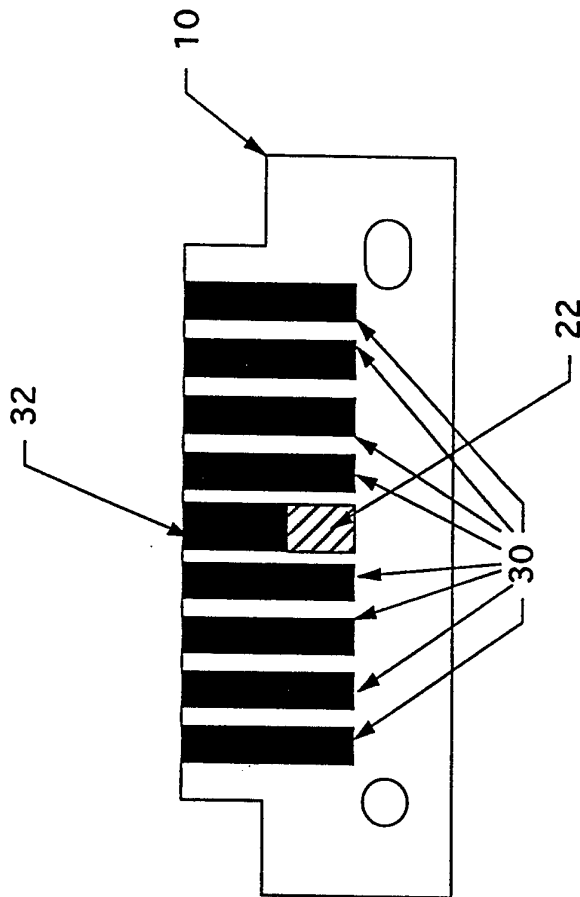

Figure 2

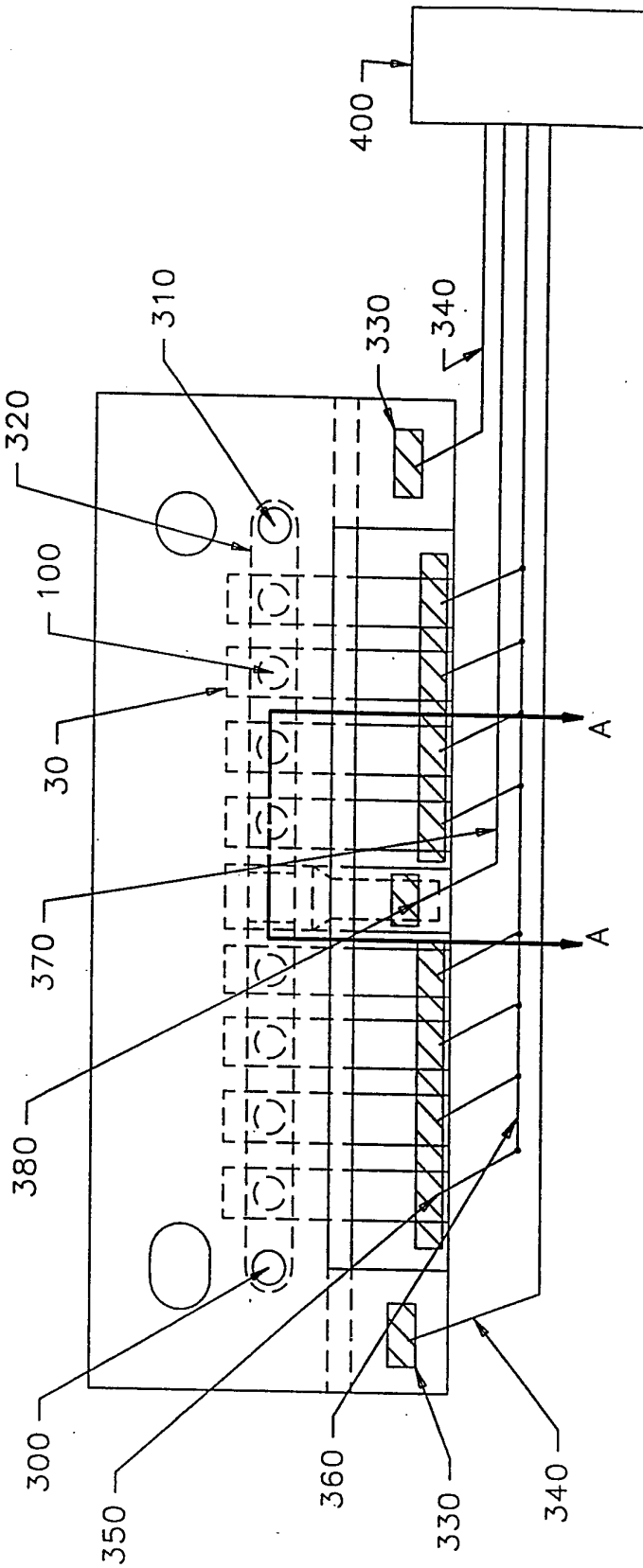

Figure 3





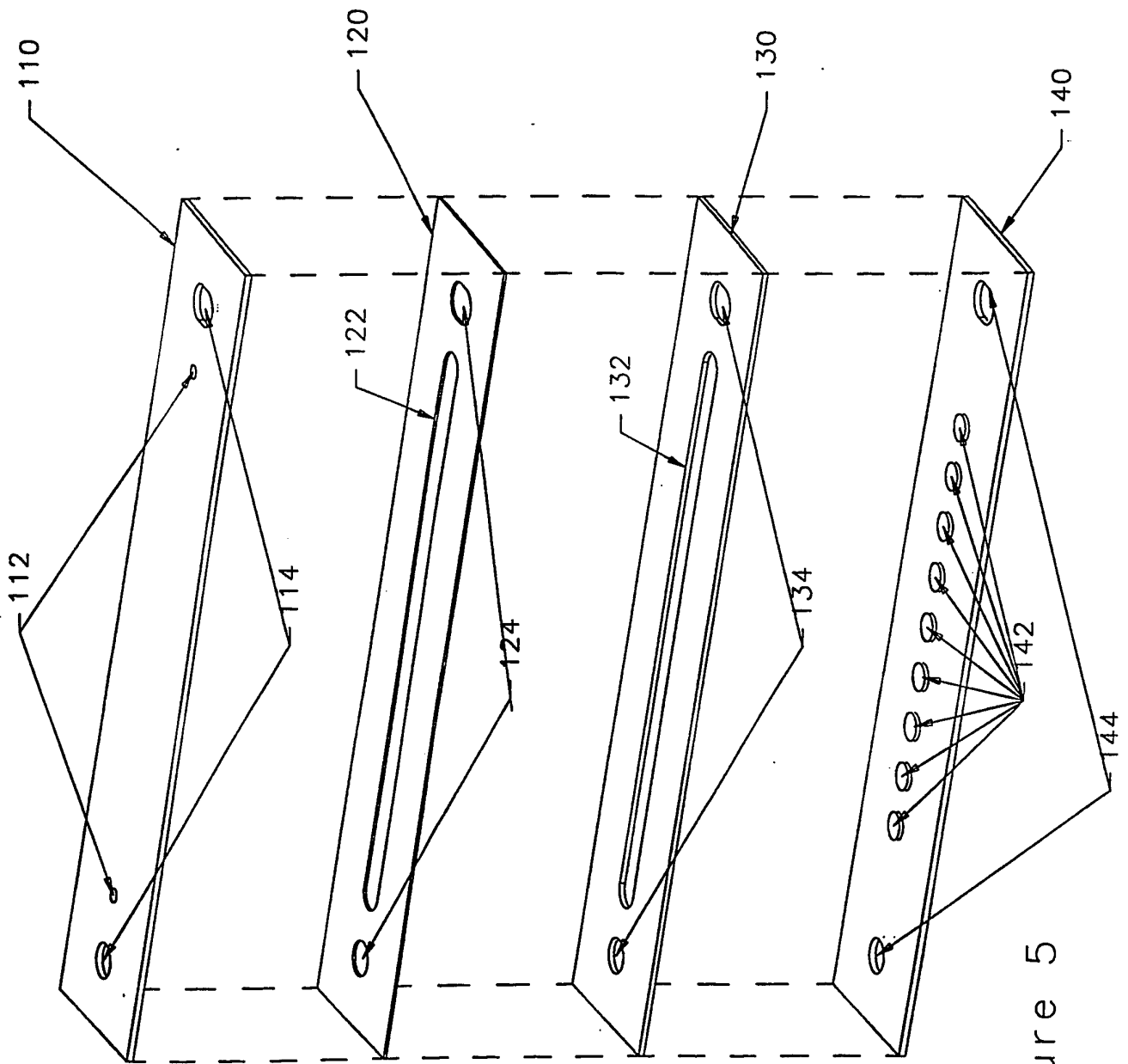

Figure 5

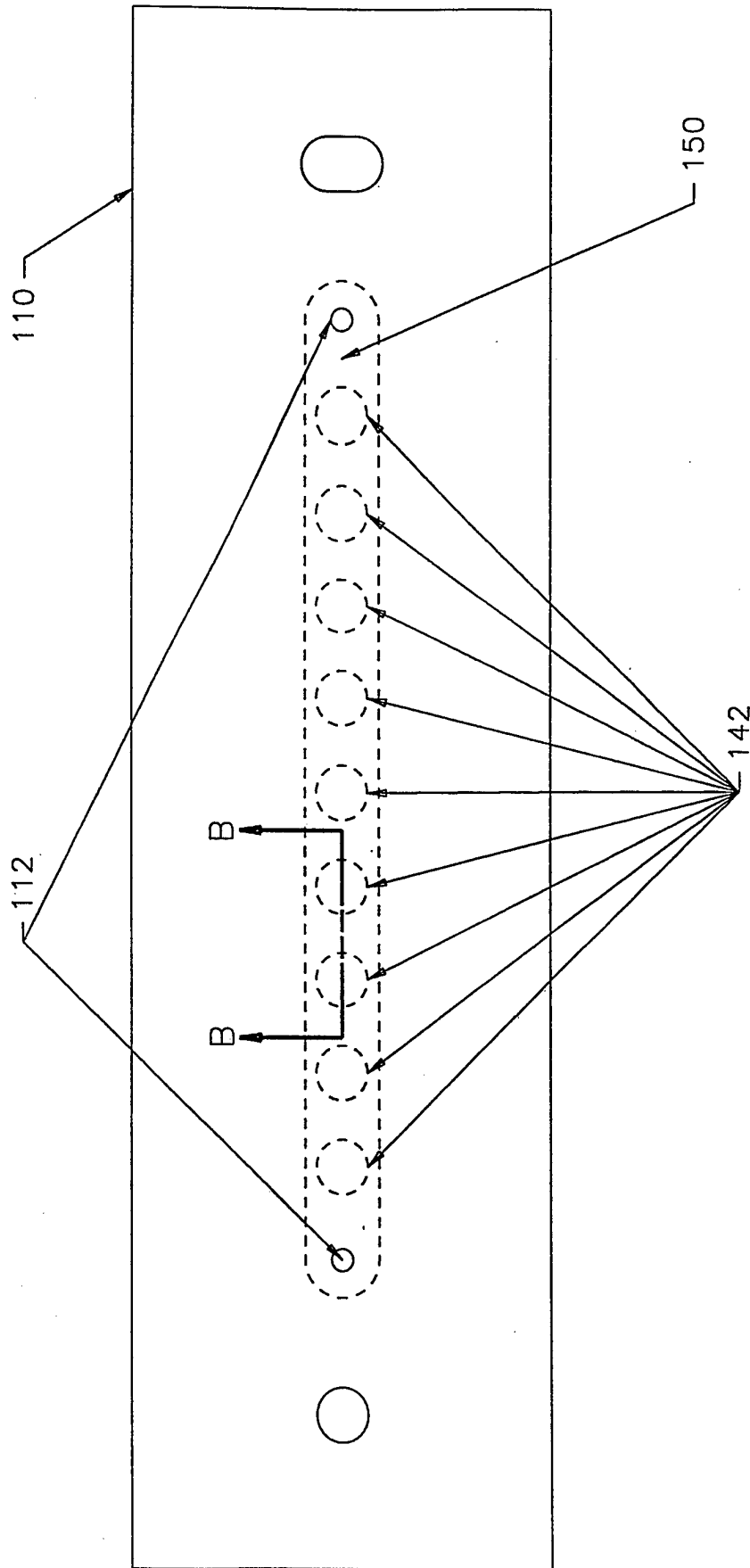

Figure 6

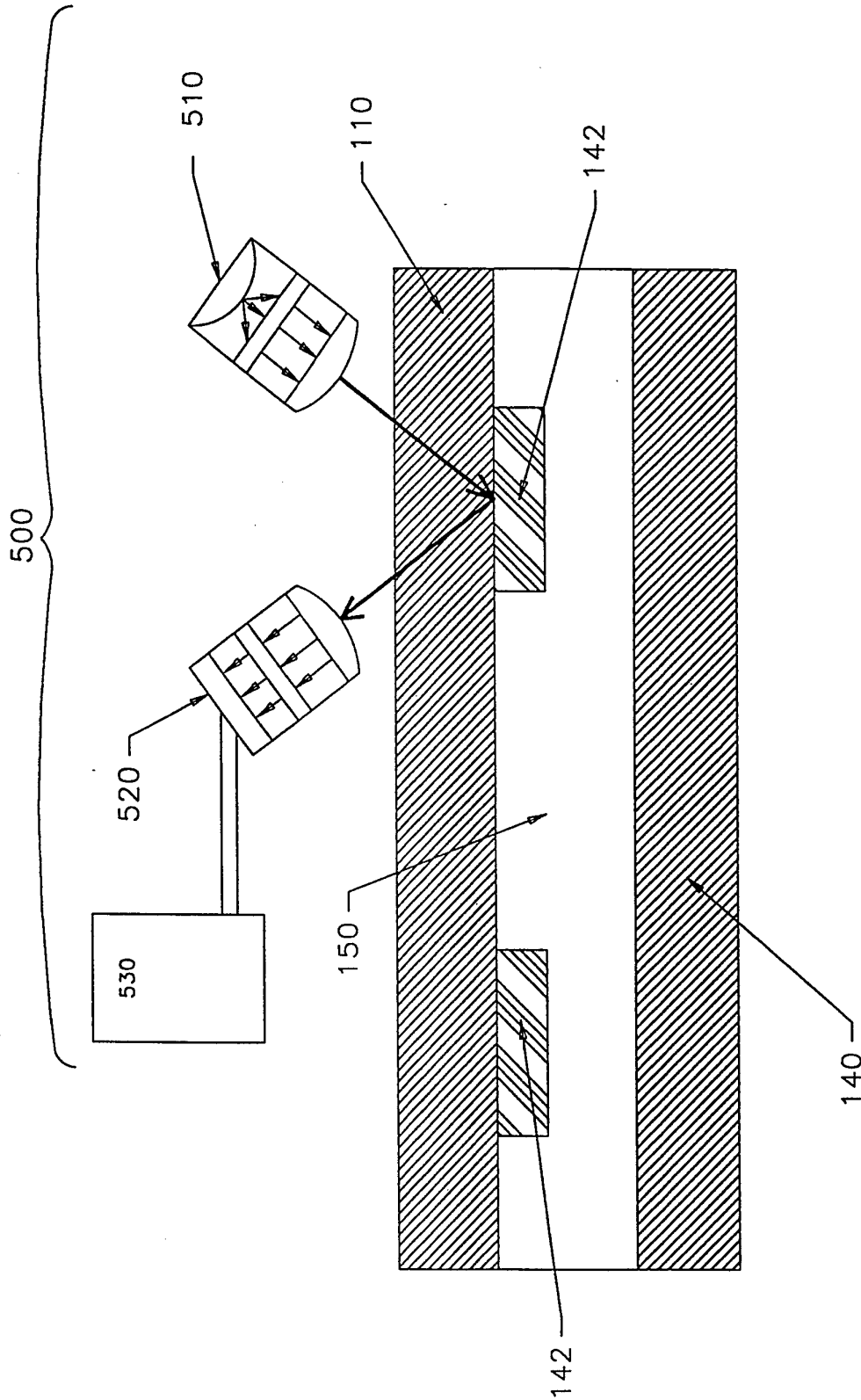
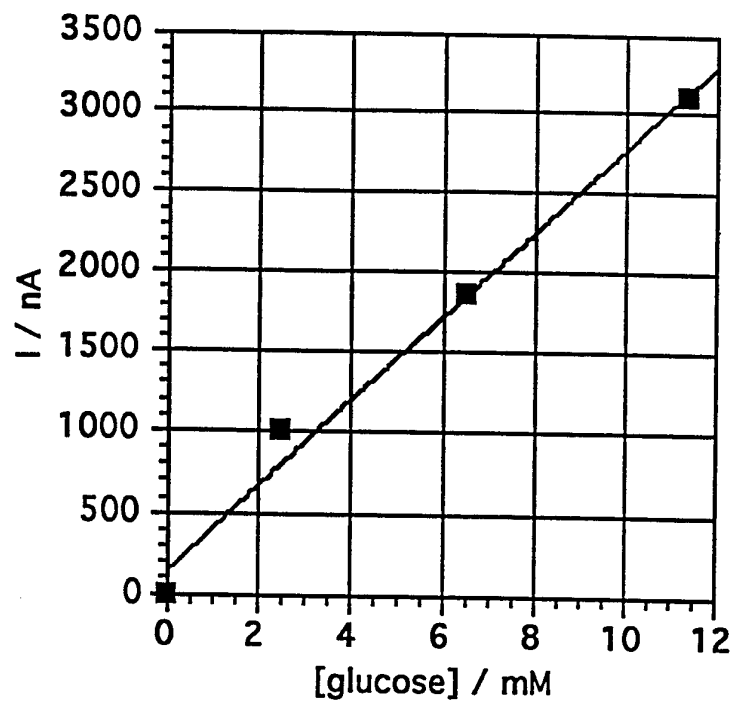

Figure 7

8 / 9



$$f(x) = 2.622951E+2 * x + 1.497951E+2$$
$$R^2 = 9.880593E-1$$

Figure 8.

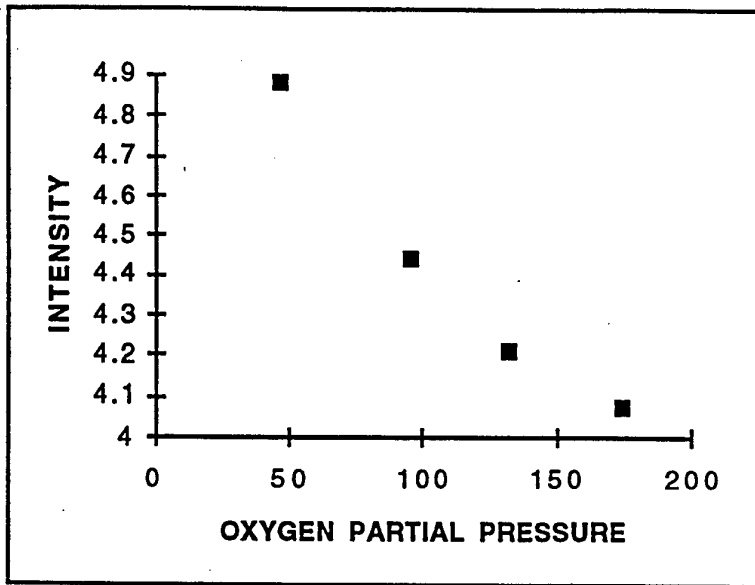

Figure 9

**INTERNATIONAL SEARCH REPORT**

Internal Application No  
PCT/US 95/01500

<b>A. CLASSIFICATION OF SUBJECT MATTER</b> IPC 6 G01N27/327 G01N31/22 C12Q1/00		
According to International Patent Classification (IPC) or to both national classification and IPC		
<b>B. FIELDS SEARCHED</b> Minimum documentation searched (classification system followed by classification symbols) IPC 6 C12Q G01N		
Documentation searched other than minimum documentation to the extent that such documents are included in the fields searched		
Electronic data base consulted during the international search (name of data base and, where practical, search terms used)		
<b>C. DOCUMENTS CONSIDERED TO BE RELEVANT</b>		
Category *	Citation of document, with indication, where appropriate, of the relevant passages	Relevant to claim No.
X	FR,A,2 643 150 (CHROMATOFIELD) 17 August 1990 see the whole document ---	1-4
A	EP,A,0 359 831 (MATSUSHITA ELECTRIC IND CO LTD) 28 March 1990 ---	
A	GB,A,1 412 001 (RADIOMETER AS) 29 October 1975 see page 2, line 91 - line 103; claims ---	5, 10, 15, 18
A	DATABASE WPI Section Ch, Week 9019 Derwent Publications Ltd., London, GB; Class A12, AN 90-143716 & JP,A,02 090 052 (TOYOBO KK) , 28 September 1988 see abstract --- -/--	5, 6
<input checked="" type="checkbox"/> Further documents are listed in the continuation of box C. <input checked="" type="checkbox"/> Patent family members are listed in annex.		
* Special categories of cited documents :		
"A" document defining the general state of the art which is not considered to be of particular relevance "E" earlier document but published on or after the international filing date "L" document which may throw doubts on priority claim(s) or which is cited to establish the publication date of another citation or other special reason (as specified) "O" document referring to an oral disclosure, use, exhibition or other means "P" document published prior to the international filing date but later than the priority date claimed		"T" later document published after the international filing date or priority date and not in conflict with the application but cited to understand the principle or theory underlying the invention "X" document of particular relevance; the claimed invention cannot be considered novel or cannot be considered to involve an inventive step when the document is taken alone "Y" document of particular relevance; the claimed invention cannot be considered to involve an inventive step when the document is combined with one or more other such documents, such combination being obvious to a person skilled in the art. "&" document member of the same patent family
Date of the actual completion of the international search  <p align="center">9 June 1995</p>		Date of mailing of the international search report  <p align="center">22.06.95</p>
Name and mailing address of the ISA European Patent Office, P.B. 5818 Patentlaan 2 NL - 2280 HV Rijswijk Tel. (+ 31-70) 340-2040, Tx. 31 651 epo nl, Fax (+ 31-70) 340-3016		Authorized officer  <p align="center">Cartagena y Abella,P</p>

# INTERNATIONAL SEARCH REPORT

International Application No  
PCT/US 95/01500

C.(Continuation) DOCUMENTS CONSIDERED TO BE RELEVANT		
Category *	Citation of document, with indication, where appropriate, of the relevant passages	Relevant to claim No.
P,A	US,A,5 312 590 (GUNASINGHAM HARI) 17 May 1994 see example 1 -----	5,6

# INTERNATIONAL SEARCH REPORT

Information on patent family members

International Application No

PCT/US 95/01500

Patent document cited in search report	Publication date	Patent family member(s)	Publication date
FR-A-2643150	17-08-90	NONE	
EP-A-0359831	28-03-90	JP-A- 1253648	09-10-89
		JP-A- 2062952	02-03-90
		JP-A- 1291153	22-11-89
		JP-B- 6058338	03-08-94
		WO-A- 8909397	05-10-89
		US-A- 5120420	09-06-92
GB-A-1412001	29-10-75	NONE	
US-A-5312590	17-05-94	NONE	