

D. Newton,

Edging Sheet-Metal.

N^o 12,282.

Patented Jan. 23, 1855.

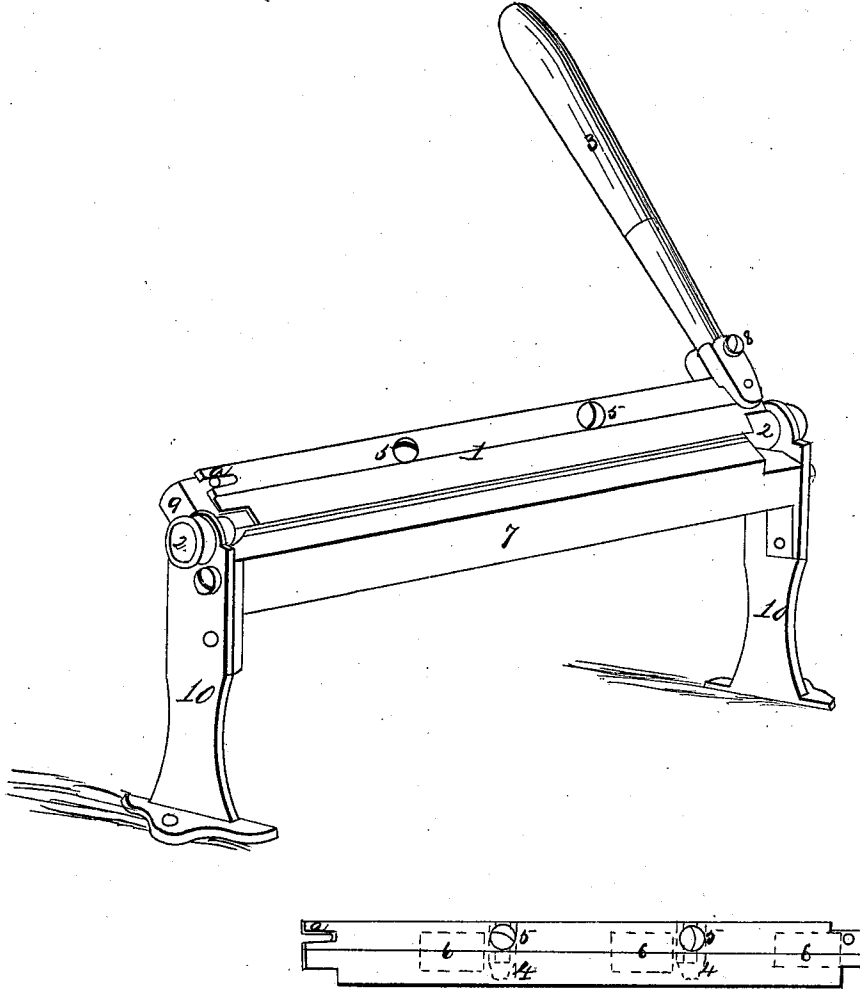

Witnesses:
Walter D. Merrill
Henry Way.

Inventor:
Daniel Newton

UNITED STATES PATENT OFFICE.

DANIEL NEWTON, OF SOUTHTINGTON, CONNECTICUT.

IMPROVEMENT IN METAL-FOLDING MACHINES.

Specification forming part of Letters Patent No. 12,282, dated January 23, 1855.

To all whom it may concern:

Be it known that I, DANIEL NEWTON, of Southington, in the county of Hartford and State of Connecticut, have invented new and useful Improvements in a Folding-Machine for Sheet Iron, Tin, Copper, &c.; and I do hereby declare that the following is a full and exact description thereof, reference being had to the accompanying drawings, and to the letters of reference marked thereon.

The nature of my invention consists in the application of three or more pairs of steel fingers by which the plate is drawn down and firmly held to the metal on which the fold is to be turned, also the gages attached to the plate by which the width of the fold is regulated.

To enable others skilled in the art to make and use my invention, I will proceed to describe its construction and operation.

I construct my folder of any suitable size and length according to the work it is designed to do. The most common length is about twenty-nine or thirty inches.

The movable part of the body of the machine is represented at Figure 9. It is a piece of cast-iron about thirty inches long and one inch and three-fourths square, with one side circled over; and the other side contains a hollow one inch wide and three-eighths deep, with bearings at each end, as shown at Fig. 2, which bearings are supported by passing through end pieces of any suitable size and shape, as shown at Fig. 10, which are bolted to the bench. The other part of the body is shown at Fig. 7, and is a straight piece of cast-iron about one and one-fourth inch thick, one and one-half deep, with the upper front corner beveled off, and a projection down at each end on the under side for the convenience of bolting it to the end pieces. In the hollow of Fig. 9 is fastened three or more steel fingers about one inch wide and one-fourth thick, beveled about one inch in length, and bent on a few degrees angle, so as to vary about one-eighth of an inch from a parallel line to every half inch in length. The plate, as shown at

Fig. 1, is a flat piece of steel about the whole length of the machine, and beveled off at the front edge suitable for turning the fold. On the under side of the plate is fastened three or more fingers exactly the same in every respect as those fastened in the hollow of Fig. 9, with the ends reversed, so as to go under those in the hollow and bear alike on each other. In the hollow of Fig. 9 is attached two springs, which bear against the plate, Fig. 1, to raise it when it is drawn back. On the under side of the plate is fastened two or more gages, (shown at Fig. 4,) to regulate the width of the fold. They are secured each by a screw. (Represented at Fig. 5.) In the left end of the plate is a short slot, in which a pin is inserted to secure a parallel motion of the plate, as shown at letter *a*. At the opposite end is a handle, Fig. 3, hung by a bolt or screw, Fig. 8. The end over the plate contains a steel pin, which passes through the handle and plate, by means of which on moving the handle to the left the plate is raised by the aid of two springs, before described, under the plate, and by reversing the motion of the handle the plate is drawn firmly to the metal while the fold is turning, then by again reversing the handle and opening the folder the metal can be removed, thus completing the operation.

What I claim as my invention, and desire to secure by Letters Patent, is—

1. The application to folders (for sheet iron, tin, copper, &c.) of three or more pairs of steel fingers, all of the same shape, one half of which are fastened to the plate which turns the fold, and the other half secured in a hollow underneath the same, the whole acting together, thereby drawing and holding the plate firmly on the metal while the fold is turning.

2. The gages attached to the plate by which the width of the fold is regulated, substantially as herein described.

DANIEL NEWTON.

In presence of—
WALTER I. MERRELL,
HENRY WAY.