



US 20060288541A1

(19) **United States**

(12) **Patent Application Publication**

Neder et al.

(10) **Pub. No.: US 2006/0288541 A1**

(43) **Pub. Date: Dec. 28, 2006**

(54) **PSEUDO-CUFFLINK ACCESSORY FOR GARMENT**

(30) **Foreign Application Priority Data**

Jun. 24, 2005 (AR) P050102593

(76) Inventors: **Camilo Jose Neder**, Ciudad de Cordoba (AR); **Diego Gustavo Jolodenco**, Ciudad de Buenos Aires (AR)

Publication Classification

(51) **Int. Cl.**

A44B 1/00 (2006.01)

(52) **U.S. Cl.** 24/90.1

Correspondence Address:

**ROGER PITT
KIRKPATRICK & LOCKHART NICHOLSON
GRAHAM LLP
599 LEXINGTON AVENUE
33RD FLOOR
NEW YORK, NY 10022-6030 (US)**

(57) **ABSTRACT**

An accessory (11) for a blouse or shirt cuff which simulates a cufflink because it is held at the same height as the cuff. The decorative element (15) is joined to an attacher element (21) which passes through the buttonhole of the cuff and is anchored beneath the unbuttoned button (27).

(21) Appl. No.: 11/426,169

(22) Filed: Jun. 23, 2006

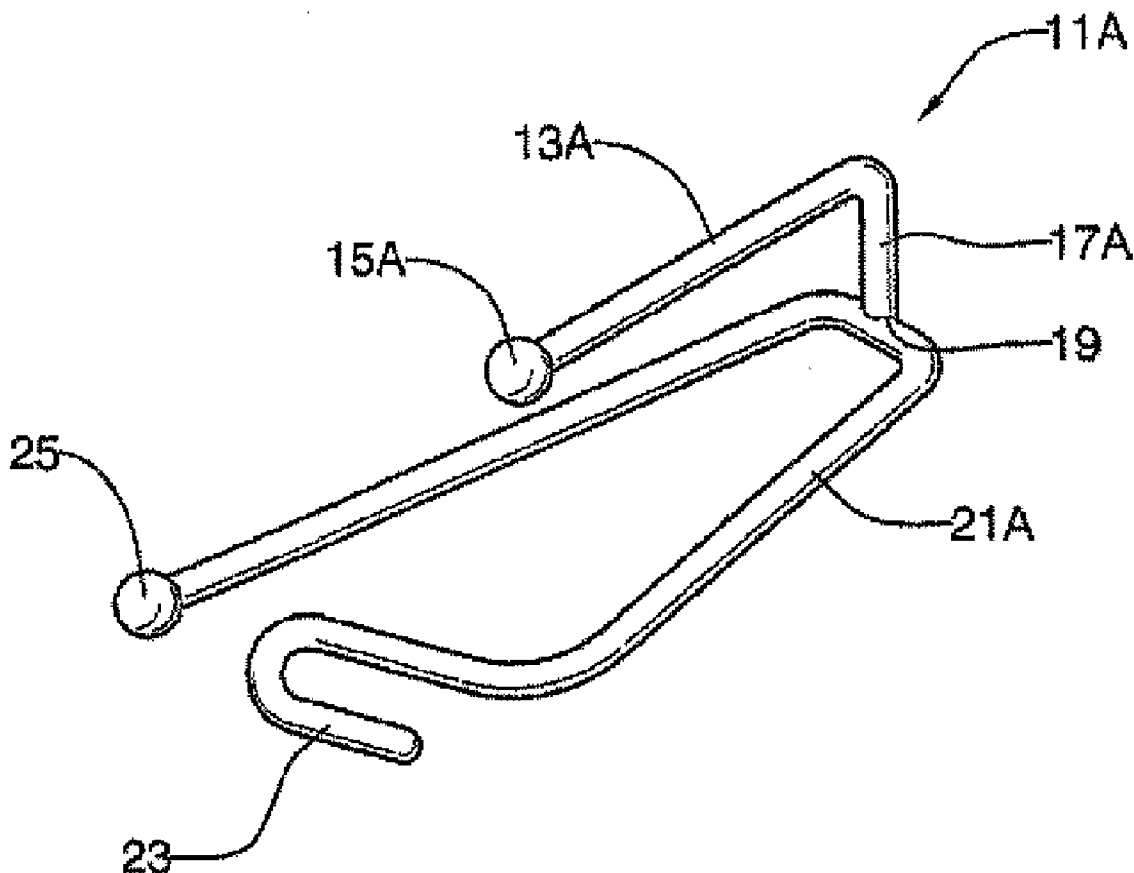

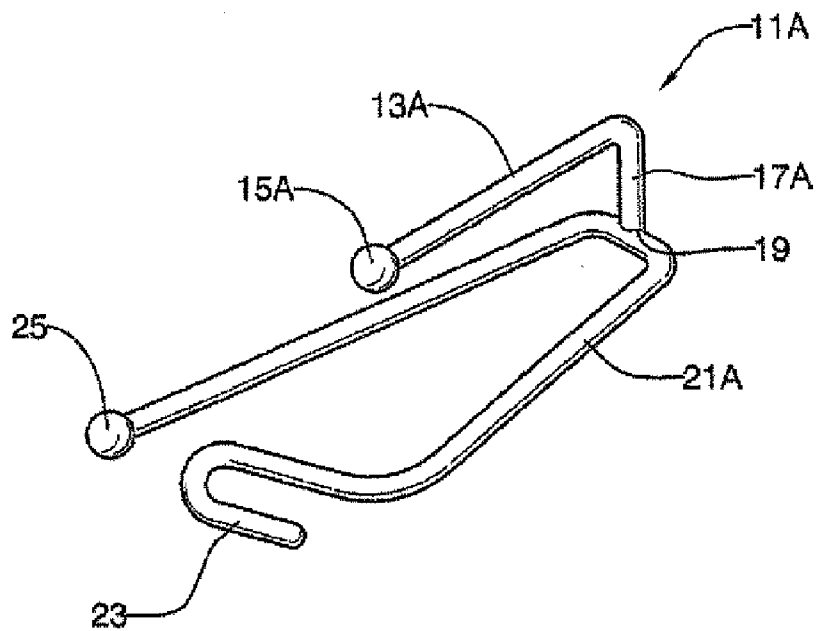

Fig. 1A

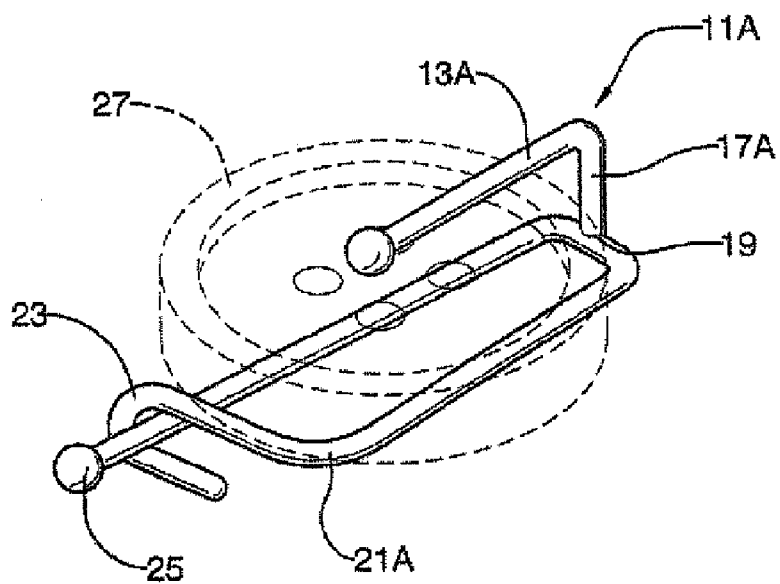

Fig. 1B

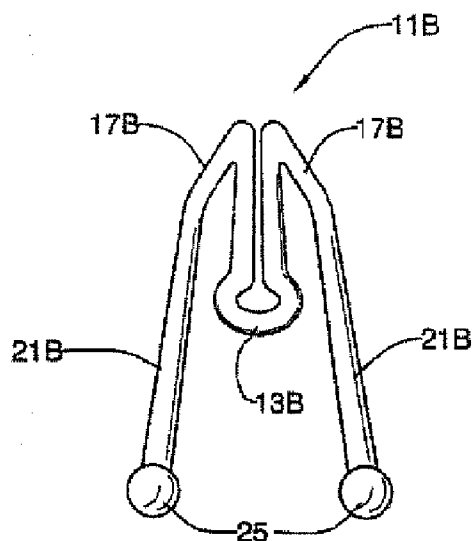

Fig. 2A

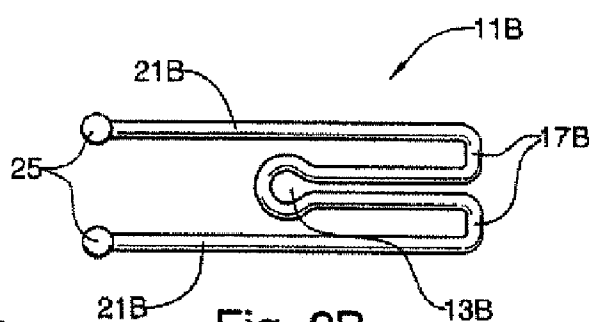

Fig. 2B

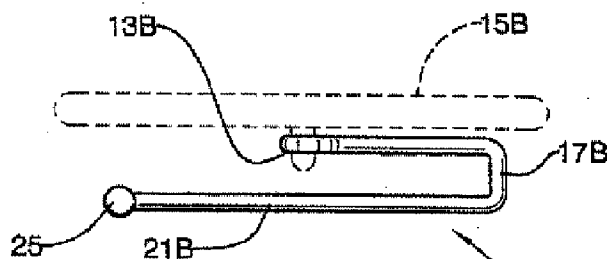

Fig. 2C

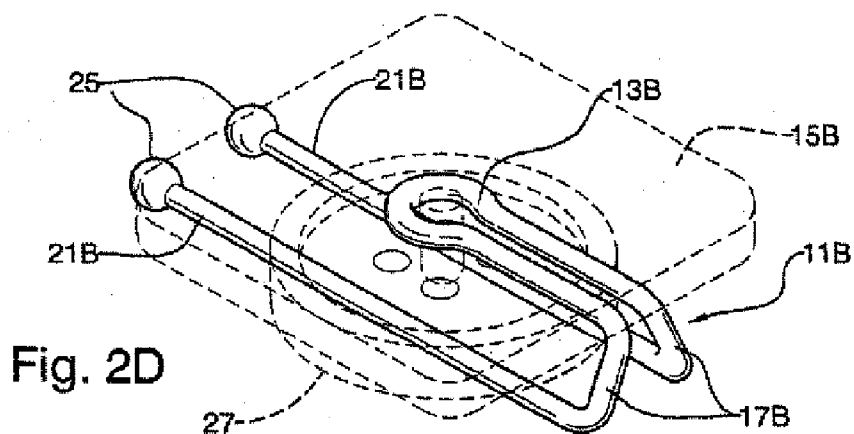

Fig. 2D

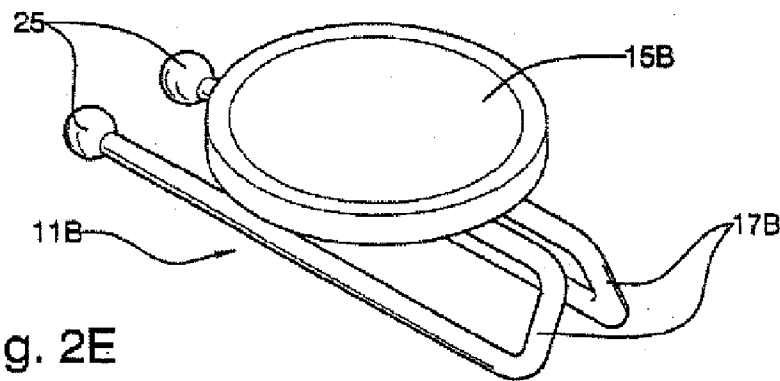

Fig. 2E

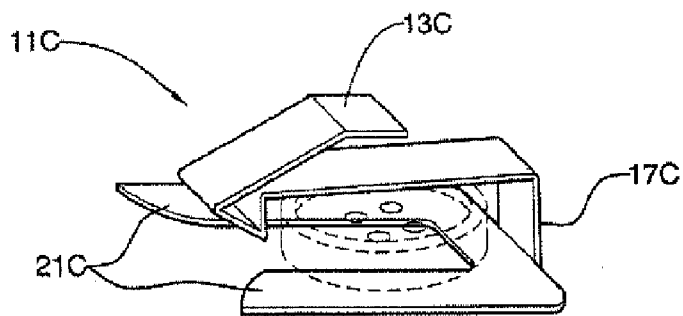

Fig. 3A

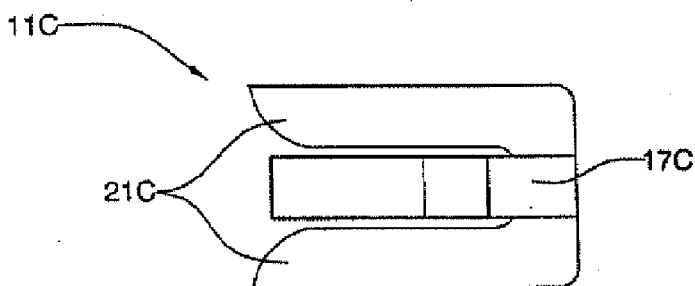

Fig. 3B

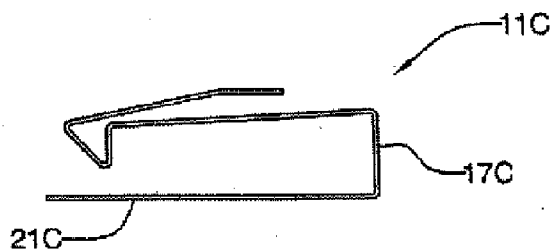

Fig. 3C

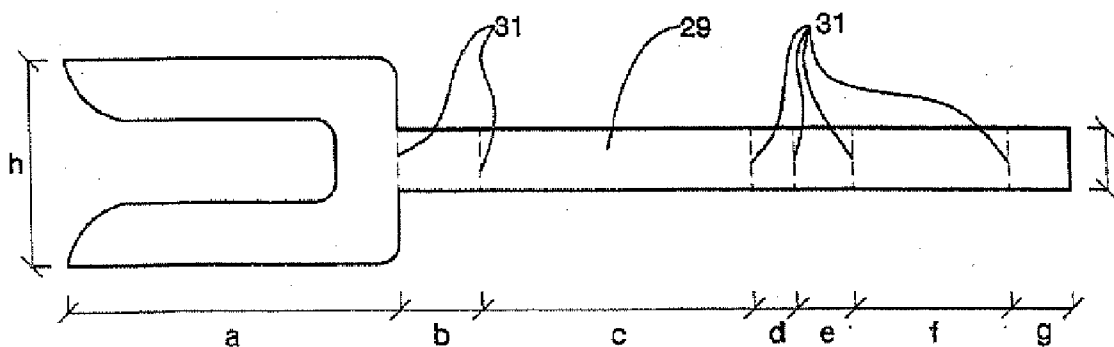

Fig. 3D

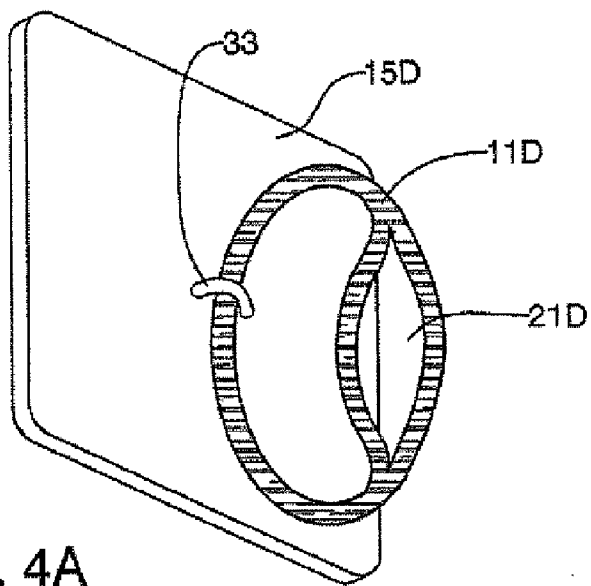

Fig. 4A

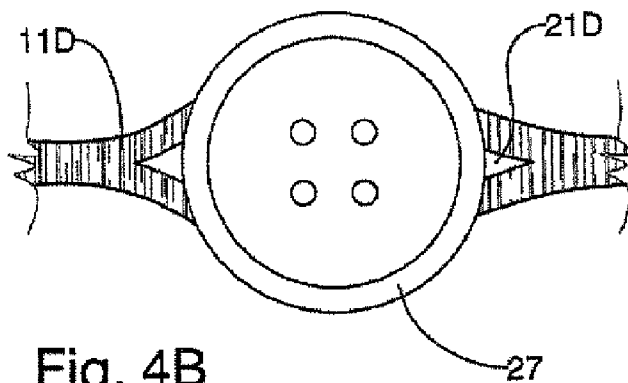

Fig. 4B

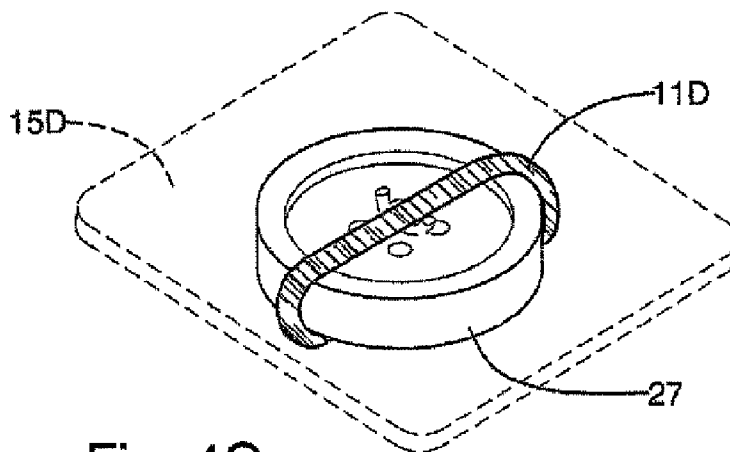

Fig. 4C

PSEUDO-CUFFLINK ACCESSORY FOR GARMENT

STATEMENT REGARDING FEDERALLY
SPONSORED RESEARCH OR DEVELOPMENT

[0001] (not applicable.)

FIELD OF THE INVENTION

[0002] This invention has an application in garments for both women and men, especially for garments which use buttons to close dress shirts and in particular for persons or occasions which may require the use of cufflinks. Though the invention herein is developed with reference to the accessory's use in cuffs of blouses and shirts as a cufflink to adorn buttonholes, its application in any other part of the garment which has a button and buttonhole closing arrangement is envisioned.

BACKGROUND OF THE INVENTION

[0003] The button and buttonhole closing arrangement is the one most widely used in shirts and other garments. It is easy and economical and it is a part of the garment. However, it is a common element which generally attracts no attention and whose only function is to provide closing, but does not serve as an ornament for the garment.

[0004] On the other hand, cufflinks have existed in the market for a long time. They can be viewed as adornments which perform the closing function, especially in cuffs, but which require the latter to have a special design with holes on both sides of the cuff and no buttons. Garments designed specifically for cufflinks are usually more formal and more expensive, since the use of adornments and accessories is not always appropriate for all occasions. Their cuffs are made with a second hole instead of a button and their ends converge to meet each other in such a way as to align the holes, unlike the button and buttonhole arrangement in which the end with the hole overlaps the end which bears the button in order to close the cuff.

[0005] In between these two closing and ornamentation systems, there is also the idea of disguising ordinary buttons with detachable elements designed to simulate cufflinks. Different kinds of these button covers have been designed, as is described in U.S. Pat. No. 3,342,250, which shows a button cover with a clip on the back to be hooked under a button previously passed through a buttonhole, or U.S. Pat. No. 4,539,731 and No. 4,817,249, for button covers whose back is comprised of a box or chest into which to insert the button that previously passed through the hole. In addition, U.S. Pat. No. 5,161,285 is related to a button cover which has a safety device to prevent its accidentally falling off and being lost.

[0006] Finally, U.S. Pat. No. 6,618,908 alludes to a cufflink for a sports shirt which is actually attached like a button cover. However, a button cover is not the same as a cufflink, nor does it perform the closing function—which is performed by the button. It is a simple adornment that is hooked onto the button once the union between the hole and the button has been made, concealing the button underneath the box or chest on which the adornment is hooked. In the aesthetic sphere as well, there are substantial differences between cufflinks and button covers, most importantly the

fact that the former are more attractive because the adornment is almost at the height of the garment while button covers are inevitably raised by the height of the button.

SUMMARY OF THE INVENTION

[0007] This invention's purpose is to meet the functional needs of cuff closure and combine the economic advantages of buttons with the aesthetic and formal benefits of cufflinks in a practical and innovative way.

[0008] According to this invention, this as well as other objectives and advantages are achieved with a garment accessory that has a button and buttonhole and also has a decorative element resembling a cufflink, joined to an attacher element that passes through the buttonhole and is then anchored in the button, with the special feature that the button is not closed. This makes it possible to maintain the decorative element almost at the same height as the garment and to close the cuff while giving the appearance and impression of its being a cufflink, except if attention is paid to the fact that the cuff's ends do not converge face-to-face but overlap each other.

BRIEF DESCRIPTION OF THE DRAWINGS

[0009] The form in which these and other objectives and advantages of the invention are achieved in practice is more clearly envisioned by making reference to the following detailed description, taking it as an example—which is in no way limiting—of the invention's preferred results, as well as to the drawings that accompany it, in which:

[0010] **FIG. 1A** is a sketch in perspective of a pseudo-cufflink accessory according to a first realization of the invention, in open form. **FIG. 1B** is a sketch in perspective analogous to **FIG. 1A** for the same accessory, but showing how it is anchored in a button.

[0011] **FIGS. 2A, 2B,** and **2C** are perspective, flat and elevated views of a pseudo-cufflink accessory according to a second realization of the invention, in open form. **FIG. 2D** is a lateral perspective view of the same accessory as in **FIG. 2A**, anchored to a button, and **FIG. 2E** is a perspective view of the accessory, in finished form complete with the decorative part.

[0012] **FIG. 3A** is a lateral perspective view of a pseudo-cufflink accessory according to a third realization of the invention, anchored to a button. **FIGS. 3B and 3C** are flat and elevation views of the same accessory as in **FIG. 3A**, anchored to a button. **FIG. 3D** is a flat sketch of a cut-off flat piece, indicating the sections to be folded to make up the accessory shown in **FIGS. 3A, 3B** and **3C**.

[0013] **FIG. 4A** is a lower perspective view of a pseudo-cufflink accessory according to a fourth realization of this invention. **FIGS. 4B and 4C** are lower flat and perspective views of the accessory in **FIG. 4A**, anchored to a button.

DETAILED DESCRIPTION OF THE
INVENTION

[0014] Given the nature of this invention, the drawings are effective to show many of the innovative features which come together and reinforce each other to confer true structural and functional relevance to the pseudo-cufflink accessory for shirt or blouse cuffs.

[0015] **FIGS. 1A and 1B** provide an example of a piece similar to a cufflink (11A) of the hook or clip type, made of a wire material which has a decorative portion (13A) 12 mm in length that comes to an ornamental protuberance (15A) at its free end. The other end of the wire decorative portion (13A) consists of a vertical part (17A) 4 mm long, designed to pass through the hole, and continuing in a union (19) with an attacher (21A) made of a wire clip with a hook (23) 14 mm long at one end which hooks into the other end of the same wire (21A) of the clip, ending in a second protuberance (25). This attacher portion (19A) forms an anchor underneath the button (27) as is shown in **FIG. 1B**.

[0016] The wire material can be $\phi 9$ mm of any kind of metal with memory, such as gold, silver, bronze, copper, aluminum, etc., or of any alloy containing at least one of them, or of any plastic material which is strong and flexible.

[0017] The realization illustrated in **FIGS. 2A to 2E** refers to a piece similar to a cufflink (11B) in the form of a folded bar which can be made of the same type and size of bar as the one described above. This is a single piece of bar, first bent over in its middle section almost 360° around a circular shape (13B) to trap an adornment (15B) which can be round, square, or have any other decorative shape, as is shown in these drawings. After a circular portion (13B), the bar continues as two continuous and parallel sections which are bent together at 90° to form the vertical section (17B) 4 mm in length, which passes through the hole before being again bent 90° to form a fork (21B) 14 mm long that ends in a pair of protuberances (25) and is simply attached by sliding it beneath the button (27), with the protuberances (25) cooperating to prevent its getting caught in the thread with which the button is sewn (27).

[0018] **FIGS. 3A, 3B and 3C** show a new realization of the accessory, obtained by folding a flat plate (29) made of a metal such as gold, silver, bronze, copper, aluminum, etc., or an alloy with memory, preferably laminated, and previously cut as shown in **FIG. 3D** which also indicates the sections (31) that are folded, having the following measurements: a=16 mm, b=4 mm, c=13 mm, d=2 mm, e=2.5 mm, f=7.5 mm, g=3 mm, h=10 mm, and i=3 mm. Alternatively, piece (11C) can be made of strong and flexible molded plastic.

[0019] As in the other realizations, the pseudo-cufflink accessory (11C) has a tongue (13C) on which a decorative piece similar to a cufflink is mounted, a perpendicular section (17C) which will pass through the hole, and a fork (21C) designed to easily pass beneath the button (27) without getting caught in the thread with which the button is sewn onto the shirt or blouse.

[0020] Finally, the accessory comprising the invention can be manufactured with a textile or analogous material, such as thread, shoelace, elastic or mix, as is illustrated in **FIGS. 4A, 4B and 4C**. This piece (11D) has a looped shape 28 mm in circumference, which is passed through an eye (33) on the underside of an adornment similar to a cufflink (15D). A lengthwise slit (21D) is made in a segment of the loop (11D) 10 mm long to emulate a buttonhole through which the button (27) of the shirt or blouse passes.

[0021] Some realizations thereof have been described for illustrative purposes, clearly showing the innovative com-

ination of features such as the anchoring mechanism attached to the button, passing through the anchor of the buttonhole and not the button, which is unbuttoned, while the decorative element is sustained at the same height on the other side of the buttonhole as in a cufflink. That is the origin of the "pseudo-cufflink" or "similar to a cufflink" terminology used to describe the accessory comprising this invention. It is expected that experts in the field will be able to think of changes and variations in the forms described above without departing from the invention's spirit and scope.

1. A pseudo-cufflink accessory for garments which has a button and a buttonhole, with a decorative element and an attacher element included in the pseudo-cufflink accessory, the attacher being joined to the decorative element and able to keep said decorative element in place at approximately the same height as the garment; wherein the fact that said attacher element is made of an anchor in said button and an intermediate portion between its union with said decorative element and said anchor which passes through said buttonhole.

2. An accessory in accordance with claim 1, wherein the fact that said anchor has a fork that is inserted beneath said button.

3. An accessory in accordance with claim 2, wherein the fact of being made of a single piece with multiple folds which define said decorative and attacher elements.

4. An accessory in accordance with claim 3, wherein the fact that said piece is a bar or pin.

5. An accessory in accordance with claim 2, wherein the fact that said fork is made of two sections of bar whose length is on the order of a button's diameter and which end in protuberances.

6. An accessory in accordance with claim 2, wherein the fact that said fork is made of two sections of bar whose length exceeds the diameter of a button and which end in a hook which closes around the button.

7. An accessory in accordance with claim 3, wherein the fact that said piece is a cut-off flat piece.

8. An accessory in accordance with claim 2, wherein the fact that said fork ends in two rounded points (to facilitate its being slid underneath the button and keep it from getting caught in the button's thread).

9. An accessory in accordance with claim 1, wherein the fact that said anchor includes a hook or clip capable of closing underneath said button.

10. An accessory in accordance with claim 2, wherein the fact that said attacher element is welded to said decorative element.

11. An accessory in accordance with claim 2, wherein the fact that said attacher element is molded in a single piece with said decorative element.

12. An accessory in accordance with claim 1, wherein the fact that said attacher element is made of a metal with memory.

13. An accessory in accordance with claim 12, wherein the fact that said metal is one chosen from the group comprised of gold, silver, bronze, copper, or their alloys.

14. An accessory in accordance with claim 1, wherein the fact that said attacher element is made of a strong and flexible plastic.

15. An accessory in accordance with claim 1, wherein the fact that said attacher element is a loop of ribbon having a lengthwise slit in a segment thereof capable of anchoring said button by emulating a buttonhole.

16. An accessory in accordance with claim 15, wherein the fact that said loop of ribbon is made of a material chosen from the group comprising of thread, shoelace, elastic, or any of their combinations.

17. An accessory in accordance with claim 1, wherein the fact that said anchor is a button which remains unbuttoned after passing through the buttonhole which overlaps the button.

* * * * *