

12

EUROPEAN PATENT APPLICATION

21 Application number: 83303246.9

51 Int. Cl.³: H 01 R 31/02

22 Date of filing: 06.06.83

30 Priority: 17.06.82 FR 8210575

43 Date of publication of application:
04.01.84 Bulletin 84/1

84 Designated Contracting States:
BE DE FR GB IT NL

71 Applicant: AMP INCORPORATED
Eisenhower Boulevard
Harrisburg Pennsylvania(US)

72 Inventor: Allais, Bernard
8 Chemin des Jonquilles
F-95520 Osny(FR)

72 Inventor: Fruchard, Charles
9 Allée Paul Valéry
F-78700 Conflans Sainte Honorine(FR)

74 Representative: Gray, Robin Oliver et al,
BARON & WARREN 18 South End Kensington
London W8 5BU(GB)

54 **Electrical tab connector and tab plate therefor.**

57 An electrical connector and a tab plate therefor.

The connector comprises a first tab plate (4) in the form of a metal sheet (5) from which a plurality of tabs (18) has been struck out so as to be upstanding from the sheet (5) and so as to leave openings (26) therein and an insulating housing (2) secured to the tab plate (4) and surrounding the tabs (18) thereof.

A second and similar tab plate (4), also secured to the housing (2), is arranged in superposition with the first tab plate (4), the tabs (18) of the second tab plate (4) extending into the housing (2) through the openings (26) in the first tab plate (4).

The tabs of each tab plate may be arranged in rows, the numbers of tabs (18) in each row, being unequal and the first tab plate (4) housing at least one sheet (28) for receiving a tab of the second tab plate (4').

EP 0 097 445 A1

./...

ELECTRICAL TAB CONNECTOR AND TAB PLATE THEREFOR

There is disclosed in US-A-2,985,861 and US-A-3,670, 295, an electrical connector comprising a tab plate in the form of a metal sheet from which upstands a plurality of
5 tabs, and an insulating housing secured to the tab plate and surrounding the tabs thereof. The invention also relates to a tab plate for the connector.

Such connectors are commonly used for grounding electrical leads, which can be connected to the tabs
10 of the connector by means of electrical tab receptacles.

It is desirable in the interests of economy of space and of the housing material that the housing should accommodate as many tabs as possible.

15 The present invention is intended to enable this advantage, and to provide a connector which is nevertheless most economical to produce.

According to one aspect of the invention an electrical connector according thereto is characterised
20 in that a second and similar tab plate is also secured to the housing and is arranged in superposition with the first tab plate, tabs of the second tab plate extending into the housing through openings in the first tab plate, left by the striking out of the tabs
25 thereof.

A tab plate for a connector according to the invention comprises a first row of equally spaced,

0097445

upstanding tabs struck out from a metal sheet, and is characterised by a second row of upstanding tabs also struck out from the sheet and comprising one less tab than the first row, each tab of the second row, a through slot dimensioned to allow a tab to be passed therethrough being formed in the metal sheet at an end of the second row and in alignment with an end tab of the first row, the slot being adjacent to an end tab of the second row.

An embodiment of the invention will now be described by way of example, with reference to the accompanying drawings which is an exploded perspective view of an electrical grounding connector.

The connector consists of an insulating housing 2, and two similar tab plates 4 and 4'.

The housing 2 is in the form of a substantially rectangular frame consisting of opposed end walls 6, opposed side walls 8 which are of greater length than the walls 6 and are formed integrally with the walls 6, and a central partition 10 also formed integrally with the end walls 6 and extending parallel to the side walls 8. Each side wall 8 is formed, internally of the housing 2, with five grooves 12 which run perpendicularly to the length of the wall 8 and each of which opens at one end into one longitudinal edge 14 of the wall 8. Each groove 12 terminates, in a shoulder 16, short of the opposite longitudinal edge of the wall 8, a portion 17 of the wall 8 thus extending between such edge and the shoulder 16. The housing 2 can be very simply moulded in one piece.

Each tab plate 4 and 4' has five upstanding electrical tabs 18 arranged in two juxtaposed rows 20 and 22, respectively, the row 20 consisting of three tabs and the row 22 of only two tabs. Each tab of the row 22 is coplanar with a tab of the row 20, the planes of the tabs being mutually parallel.

Mounting lugs 24 provided with holes 25 for bolts or other fasteners (not shown) extend centrally from opposite edges of each tab plate 4 and 4' at right angles to the rows 20 and 22 of tabs 18.

5 In the manufacture of each tab plate 4 and 4' by means of a progressive die forming operation, the tabs 18 were struck out from a metal sheet 5, thereby leaving an opening 26 therein adjacent to each tab, and there being an opening 26 between each pair of
10 adjacent tabs of each row. Each plate 4 and 4' was also formed with a tab-receiving through slot 28 at one end of the row 22 of tabs, in alignment with an end tab of the row 20 and opposite to an end tab of the row 22.

15 The tabs 18 of the tab plate 4' were made longer than those of the tab plate 4 by the thickness of the metal sheet 5.

Adjacent to its junction with the sheet 5, each tab 18 has a pair of laterally projecting stops 30 and 30', for limiting the insertion of the tab into a tab receptacle (not shown) to be mated therewith. The stop 30', which is directed outwardly of the tab plate 4 or 4', is formed with a notch 32 providing a retention lug 33.

25 When assembling the grounding connector, the tab plates 4 and 4' are arranged, as shown, in superposed relationship, with the lugs 24 of the two plates 4 and 4' in precise alignment and with each of the openings 26 between the tabs of the row 20 of
30 the upper (as seen in the drawing) plate 4, in alignment with a tab of the row 22 of the lower (as seen in the drawing) plate 4', each opening 26 of the row 22 of the upper plate 4 being aligned with a tab of the row 20 of the lower plate 4' and the slot 28
35 of the upper plate 4 being aligned with the rearmost

(as seen in the drawing) tab of the row 20 of the lower plate.

5 The upper plate 4 is then nested with the lower plate 4' in the direction of the arrow A so that the two plates are interengaged with their lugs 24 contiguous and in precise alignment. The rearmost tab 18 of the row 20 of the lower plate projects through the slot 28 of the upper plate and each of the remaining tabs 18 of the lower plate projects through an immediately superposed
10 opening 26 of the upper plate.

15 With the plates 4 and 4' so nested with their tabs 18 interdigitated, the housing 2 is lowered onto the plates 4 and 4' in the direction of the arrow B, so that each retention lug 33 snaps into the adjacent groove 12 and engages against the shoulder 16 at the base thereof, the portion 17 of the wall 8 between the shoulder 16 and the lower edge of such wall, engaging
20 in the notch 32 below the lug 33. The housing 2 is thereby secured to the plates 4 and the plates 4 are secured together in their superposed relationship, the tabs being surrounded by the housing 2 and projecting thereinto to an equal extent, since the tabs 18 of the plate 4' are longer than those of the plate 4, as mentioned above.

25 In order to facilitate their snap engagement in the grooves 12, the lugs 33 have end faces 35 which are inclined with respect to the vertical so as to cam the walls 8 of the housing 2 slightly outwardly as it is assembled to the plates 4, whereafter these walls
30 return by virtue of the natural resilience of the walls 8.

35 In the connector, when so assembled, the central partition 10 of the housing 2 extends between the two rows of tabs 18 therein, each of which rows consists of five tabs, that is to say, two tabs of one of the tab plates and three tabs of the other.

0097445

The assembled connector can be secured to an electrically conductive support e.g. the chassis of an automobile, or of an electrical appliance, by means of bolts or other fasteners passed through the holes
5 25. Leads (not shown) can be connected to the tabs 18 by means of tab receptacles (not shown).

Since the number of tabs that can be struck out from a metal sheet is limited by the area thereof, the connector has the advantage that a double density of
10 tabs can be provided in the same housing as compared with the case where a single tab plate is used. Since the plates 4 are similar, they can be made by means of the same forming dies, simple conversion means being
15 Thus, both of the tab plates are preferably provided with a slot 28. The housing 2 is uncomplicated and is therefore simple to mould in one piece.

The tab plates may, if desired be provided with only one row of tabs or with more than two such rows,
20 and more than one slot may be provided in each plate; such slot may open into an adjacent edge of the plate. Instead of, or additionally to, the lugs 24, each tab plate may have a central mounting hole for receiving a bolt. These central holes being in register when the
25 tab plates are assembled to the housing. The lower tab plate is preferably provided with means, which may be in the form of lances struck out therefrom, for making electrical contact with the support through paint thereon.

Claims:

1. An electrical connector comprising a first tab plate (4) in the form of a metal sheet (5) from which upstands a plurality of tabs (18), and an insulating housing (2) secured to the tab plate (4) and surrounding the tabs (18) thereof; characterised in that the tabs (18) have been struck out from the sheet (5) in such a way as to leave openings (26) therein; and in that a second and similar tab plate (4') is also secured to the housing (2) and is arranged in superposition with the first tab plate (4), tabs (18) of the second tab plate (4') extending into the housing (2) through the openings (26) in the first tab plate (4).

2. A connector according to Claim 1, characterised in that the tabs of the first and second tab plates are identically arranged, each tab plate (4 and 4') having a plurality of juxtaposed rows (20 and 22) of tabs (18), a tab (18) of the second tab plate (4') at an end of one (20) of the rows of tabs thereof, which row (20) comprises one tab (18) more than an adjacent row (22) of tabs of the second tab plate (4'), extending into the housing (2) through a slot (28) formed in the first tab plate (4).

3. A connector according to Claim 2, characterised in that the planes of the tabs (18) of each tab plate (4) are parallel, each tab of the adjacent row (22) being coplanar with a tab (18) of the one row (20), the slot (28) being positioned at an end of the adjacent row (22) of tabs of the first tab plate (4), in line with a tab (18) at the end of the one row (20) of tabs thereof and opposite to a tab (18) at the end of the adjacent row (22) of tabs thereof.

4. A connector according to Claim 1, 2 or 3, characterised in that each tab plate (4 and 4') is

provided with a mounting lug (24) the mounting lugs (24) of the two tab plates (4 and 4') being arranged in superposed relationship and in precise alignment with one another.

5 5. A connector according to any one of the preceding claims, characterised in that the housing (2) is in the form of a frame having side walls (8) formed with grooves (12) receiving retention lugs (33) projecting laterally of the tabs (18) and
10 engaging shoulders (16) at the ends of the grooves (12).

 6. A connector according to Claim 5, characterised in that the housing (2) consists of
15 opposed end walls (6) formed integrally with the side walls (8) and a central partition (10) formed integrally with the end walls (6) and extending between two rows of tabs (18) of the tab plates (4 and 4').

 7. A connector according to Claim 5 or 6, characterised in that the retention lugs (33) are formed
20 with cam surfaces (35) for camming the side walls (8) resiliently apart, as the housing (2) is assembled to the tab plates (4 and 4'), so that the retention lugs (33) engage in the grooves (12) with a snap action.

25 8. A connector according to Claim 7, characterised in that portions (17) of the side walls (8), between the shoulders (16) and the adjacent edges of the side walls (8), are received in notches (32) in stops (30') on the tabs (18), from which stops
30 (30') the retention lugs (33) project.

 9. A connector according to any one of the preceding claims, characterised in that the tabs (18) of the second tab plate (4') are longer than the tabs (18) of the first tab plate (4) by the thickness of
35 the metal sheet (5).

10. A tab plate for a connector according to Claim 1, comprising a first row (20) of equally spaced, upstanding tabs (18) struck out from a metal sheet (5), characterised by a second row (22) of upstanding tabs (18) also struck out from the sheet (5) and comprising one less tab (18) than the first row (20), each tab (18) of the second row (22) being coplanar with a tab (18) of the first row (20), a through slot (28) dimensioned to allow a tab (18) to be passed therethrough being formed in the metal sheet (5) at an end of the second row (22) and in alignment with an end tab (18) of the first row (20), the slot (28) being adjacent to an end tab (18) of the second row (22).

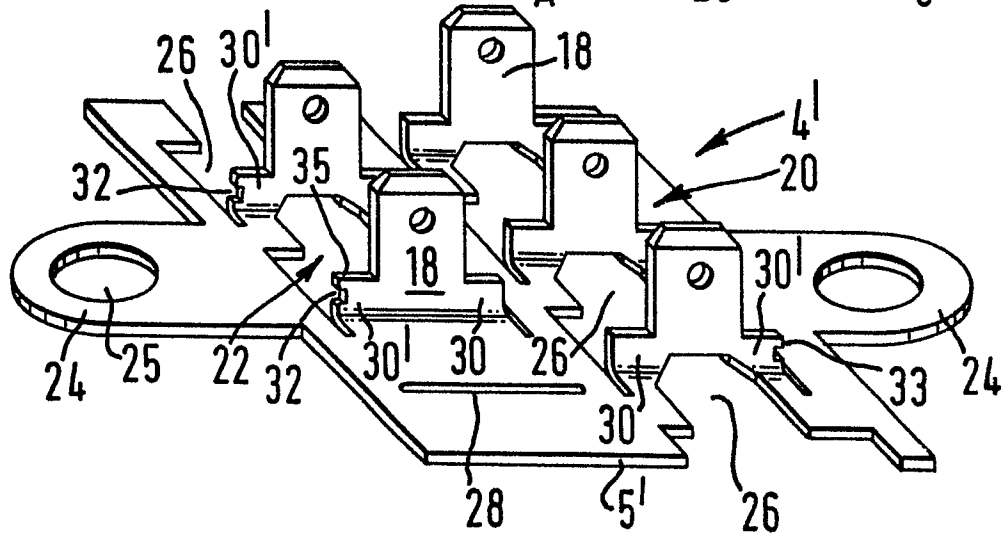
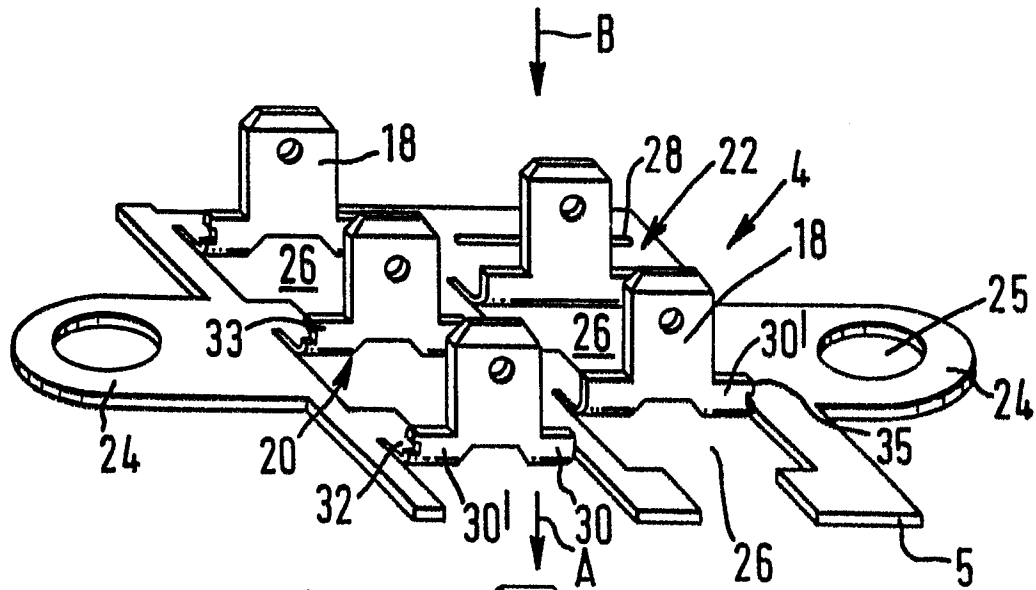
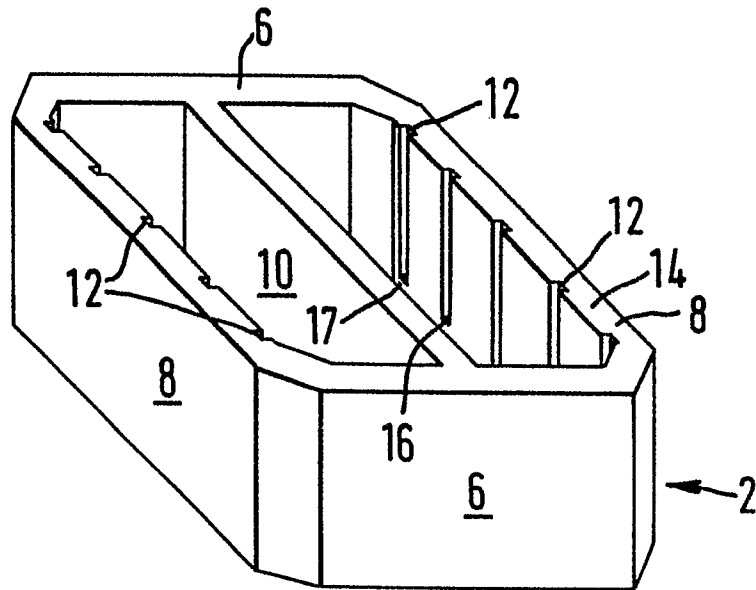



DOCUMENTS CONSIDERED TO BE RELEVANT			
Category	Citation of document with indication, where appropriate, of relevant passages	Relevant to claim	CLASSIFICATION OF THE APPLICATION (Int. Cl. *)
A	DE-C- 913 191 (JUNG) * Figure 1; page 2, lines 37-102 *	1	H 01 R 31/02
A	--- US-A-3 064 224 (BRYANT ELECTRIC COMPANY) * Figures 1-3; column 2, line 67 - column 3, line 55 *	1,4	
D,A	--- US-A-3 670 295 (UNDERWRITERS SAFETY) * Figures 11,12; column 2, line 65 - column 3, line 10; column 5, lines 25-44 *	1,5,7,8	
D,A	--- US-A-2 985 861 (BURNDY CORP.) * Figure 1; column 2, lines 4-16 *	1,3,9	
A	--- FR-A-1 574 163 (ATELIERS DE CONSTRUCTIONS ELECTROMECHANIQUES) * Figure 9; page 2, lines 34-39 *		TECHNICAL FIELDS SEARCHED (Int. Cl. *) H 01 R 13/00 H 01 R 25/00 H 01 R 31/00
The present search report has been drawn up for all claims			
Place of search THE HAGUE		Date of completion of the search 28-07-1983	Examiner WAERN G.M.
CATEGORY OF CITED DOCUMENTS		T : theory or principle underlying the invention E : earlier patent document, but published on, or after the filing date D : document cited in the application L : document cited for other reasons & : member of the same patent family, corresponding document	
X : particularly relevant if taken alone Y : particularly relevant if combined with another document of the same category A : technological background O : non-written disclosure P : intermediate document			