



INTERNATIONAL APPLICATION PUBLISHED UNDER THE PATENT COOPERATION TREATY (PCT)

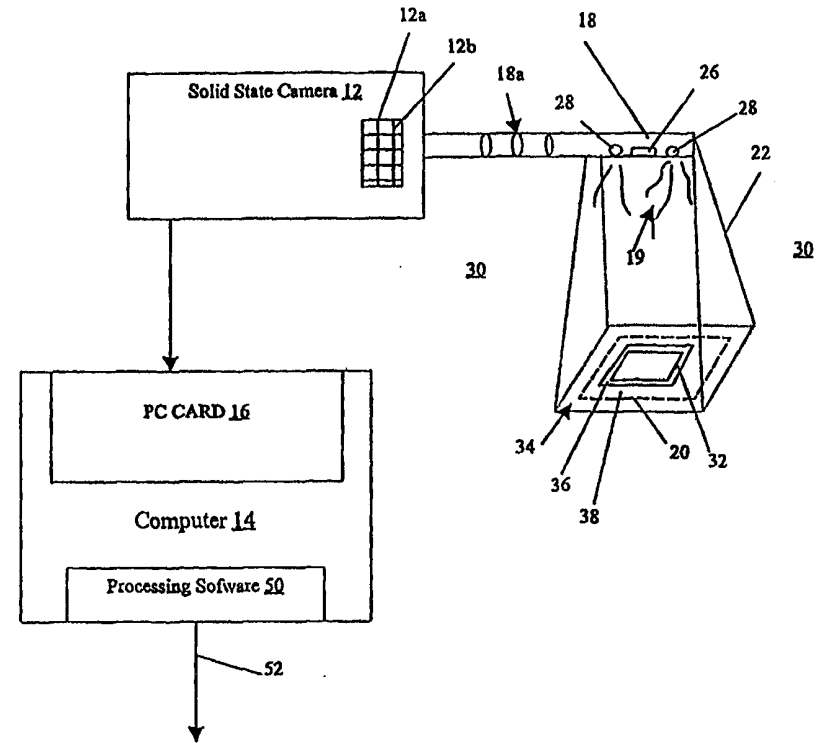
<b>(51) International Patent Classification</b> <sup>7</sup> : <b>A61C 5/00</b>	<b>A1</b>	<b>(11) International Publication Number:</b> <b>WO 00/25696</b> <b>(43) International Publication Date:</b> 11 May 2000 (11.05.00)
--	-----------	--

<p><b>(21) International Application Number:</b> PCT/US99/22857</p> <p><b>(22) International Filing Date:</b> 4 October 1999 (04.10.99)</p> <p><b>(30) Priority Data:</b></p> <table border="0"> <tr> <td>60/106,920</td> <td>3 November 1998 (03.11.98)</td> <td>US</td> </tr> <tr> <td>60/109,299</td> <td>19 November 1998 (19.11.98)</td> <td>US</td> </tr> <tr> <td>60/120,596</td> <td>18 February 1999 (18.02.99)</td> <td>US</td> </tr> <tr> <td>60/120,612</td> <td>18 February 1999 (18.02.99)</td> <td>US</td> </tr> </table> <p><b>(71) Applicant (for all designated States except US):</b> SHADE ANALYZING TECHNOLOGIES, INC. [US/US]; 5 Brook Street, Darien, CT 06820 (US).</p> <p><b>(72) Inventors; and</b></p> <p><b>(75) Inventors/Applicants (for US only):</b> LEHMANN, Maryann [US/US]; 6 Joseph Street, Darien, CT 06820 (US). YOUNGS, Perry [GB/GB]; Back Lane, Burgh End, Mat-tishal, Dereham, Norfolk NR20 3QX (GB). VOCK, Curtis, A. [US/US]; 1279 Elder Avenue, Boulder, CO 80304 (US).</p> <p><b>(74) Agents:</b> FANUCCI, Allan, A. et al.; Pennie &amp; Edmonds LLP, 1155 Avenue of the Americas, New York, NY 10036 (US).</p>	60/106,920	3 November 1998 (03.11.98)	US	60/109,299	19 November 1998 (19.11.98)	US	60/120,596	18 February 1999 (18.02.99)	US	60/120,612	18 February 1999 (18.02.99)	US	<p><b>(81) Designated States:</b> AE, AL, AM, AT, AU, AZ, BA, BB, BG, BR, BY, CA, CH, CN, CU, CZ, DE, DK, EE, ES, FI, GB, GD, GE, GH, GM, HR, HU, ID, IL, IN, IS, JP, KE, KG, KP, KR, KZ, LC, LK, LR, LS, LT, LU, LV, MD, MG, MK, MN, MW, MX, NO, NZ, PL, PT, RO, RU, SD, SE, SG, SI, SK, SL, TJ, TM, TR, TF, UA, UG, US, UZ, VN, YU, ZA, ZW, ARIPO patent (GH, GM, KE, LS, MW, SD, SL, SZ, TZ, UG, ZW), Eurasian patent (AM, AZ, BY, KG, KZ, MD, RU, TJ, TM), European patent (AT, BE, CH, CY, DE, DK, ES, FI, FR, GB, GR, IE, IT, LU, MC, NL, PT, SE), OAPI patent (BF, BJ, CF, CG, CI, CM, GA, GN, GW, ML, MR, NE, SN, TD, TG).</p> <p><b>Published</b> <i>With international search report.</i> <i>Before the expiration of the time limit for amending the claims and to be republished in the event of the receipt of amendments.</i></p>
60/106,920	3 November 1998 (03.11.98)	US											
60/109,299	19 November 1998 (19.11.98)	US											
60/120,596	18 February 1999 (18.02.99)	US											
60/120,612	18 February 1999 (18.02.99)	US											

**(54) Title:** INTERACTIVE DENTAL RESTORATIVE NETWORK

**(57) Abstract**

An interactive dental restoration method, a system for use between a dentist, and a dental restoration laboratory. The method includes identifying a dental restoration need in a patient; designing a preliminary treatment plan that includes design criteria for preparation of a dental prosthesis to be placed in the patient to satisfy the dental restoration need; transmitting the preliminary treatment plan via a communications network to a dental restoration laboratory; and communicating a final treatment plan, including modifications to the preliminary treatment plan where necessary, to the dentist. The system includes a computer-based dental restoration system of a network server (1610) having a database (1630), a network (1620), and at least one local computer (14). The database stores information about materials, procedures, and preparations concerning dental prostheses.



**FOR THE PURPOSES OF INFORMATION ONLY**

Codes used to identify States party to the PCT on the front pages of pamphlets publishing international applications under the PCT.

AL	Albania	ES	Spain	LS	Lesotho	SI	Slovenia
AM	Armenia	FI	Finland	LT	Lithuania	SK	Slovakia
AT	Austria	FR	France	LU	Luxembourg	SN	Senegal
AU	Australia	GA	Gabon	LV	Latvia	SZ	Swaziland
AZ	Azerbaijan	GB	United Kingdom	MC	Monaco	TD	Chad
BA	Bosnia and Herzegovina	GE	Georgia	MD	Republic of Moldova	TG	Togo
BB	Barbados	GH	Ghana	MG	Madagascar	TJ	Tajikistan
BE	Belgium	GN	Guinea	MK	The former Yugoslav Republic of Macedonia	TM	Turkmenistan
BF	Burkina Faso	GR	Greece			TR	Turkey
BG	Bulgaria	HU	Hungary	ML	Mali	TT	Trinidad and Tobago
BJ	Benin	IE	Ireland	MN	Mongolia	UA	Ukraine
BR	Brazil	IL	Israel	MR	Mauritania	UG	Uganda
BY	Belarus	IS	Iceland	MW	Malawi	US	United States of America
CA	Canada	IT	Italy	MX	Mexico	UZ	Uzbekistan
CF	Central African Republic	JP	Japan	NE	Niger	VN	Viet Nam
CG	Congo	KE	Kenya	NL	Netherlands	YU	Yugoslavia
CH	Switzerland	KG	Kyrgyzstan	NO	Norway	ZW	Zimbabwe
CI	Côte d'Ivoire	KP	Democratic People's Republic of Korea	NZ	New Zealand		
CM	Cameroon			PL	Poland		
CN	China	KR	Republic of Korea	PT	Portugal		
CU	Cuba	KZ	Kazakstan	RO	Romania		
CZ	Czech Republic	LC	Saint Lucia	RU	Russian Federation		
DE	Germany	LI	Liechtenstein	SD	Sudan		
DK	Denmark	LK	Sri Lanka	SE	Sweden		
EE	Estonia	LR	Liberia	SG	Singapore		

## INTERACTIVE DENTAL RESTORATIVE NETWORK

### TECHNICAL FIELD

The invention is directed to methods, systems and devices for dental restoration  
5 wherein communication between the dentist and restoration laboratory are held in real time  
to discuss, finalize and optimize a treatment plan for a patient. More specifically, the  
invention is directed to an interactive computer-based system and method to enable the  
dentist and restoration laboratory to analyze color images of one or more teeth and teeth  
preparation so that a replacement tooth or crown can be particularly designed to precisely  
10 match the tooth that is to be replaced in certain clinical or cosmetic procedures.

### BACKGROUND OF THE INVENTION

Restorative dentistry is the art and science of replacing or restoring lost tooth  
structure. The amount of tooth structure to be replaced determines what path the operator  
15 takes - whether the restoration will be a crown, bridge, inlay, onlay or direct restoration  
(i.e., a filling). The choice of that path in the past was more simple, due to the limited  
number of materials and techniques available. For example, U.S. Patents 5,766,006 and  
5,961,324 describe methods and systems for determining tooth color information based  
upon digital images provided by a camera and then matching the color of the restoration  
20 article (i.e., dental prosthesis) with the determined tooth color. In recent years, however,  
with the advent of new materials and concepts, treatment choices have expanded in a  
phenomenal way. Dentists are now facing an overload of information in trying to decide  
which materials and procedures are the best suited for their particular cases. What the state-  
of-the-art practitioner needs is a source to be able to go to, at a moment's notice, that will be  
25 able to aid him and his lab if necessary in treatment planning and delivering the best  
restorative dentistry possible, utilizing the most appropriate materials available today. The  
present invention now satisfies this need.

### SUMMARY OF THE INVENTION

30 The invention relates to an interactive dental restoration method between a dentist  
and a dental restoration laboratory. The basic steps of this method include identifying a  
dental restoration need in a patient; designing a preliminary treatment plan that includes  
design criteria for preparation of a dental prosthesis to be placed in the patient to satisfy the  
dental restoration need; transmitting the preliminary treatment plan via a communications  
35 network to a dental restoration laboratory; and communicating a final treatment plan,  
including modifications to the preliminary treatment plan where necessary, to the dentist.

Typically, the final treatment plan includes information about materials for preparing a dental prosthesis that satisfies the design criteria, and the dental prosthesis is then prepared for placement in the patient. This method enables optimization of the dental restoration with significant savings in time and effort for the dentist, dental technician and the patient.

5 Generally, the dentist prepares the preliminary treatment plan and the design criteria include digital image representations of the dental restoration need. Thereafter, the preliminary treatment plan can be forwarded to and evaluated by the laboratory before a final treatment plan is formulated and communicated to the dentist. The step of transmitting and evaluating the plan are codirected over the communications network. Thus, the final  
10 treatment plan is not implemented in the patient until after interim preparation information is transmitted to the laboratory and confirmed, thus avoiding rework or revision after the plan has been implemented.

Advantageously, the design criteria or the modifications thereto include proposed decay excavation, tooth preparation, or dental prosthesis color. When a dental prosthesis  
15 such as a crown, bridge or replacement tooth is needed, the method includes verifying that the dental prosthesis is prepared according to the final treatment plan prior to placement of the dental prosthesis in the patient. In order to obtain the best color match of the dental prosthesis with the patient's teeth, the digital image representations include REAL IMAGE and REFERENCE IMAGES and the modifications include correlation of a color selection  
20 for the dental prosthesis to match the REAL IMAGE. Furthermore, the design criteria can include tooth preparation and proposed decay excavation, and the method further comprises a communication of a confirmation or modification, from the laboratory, of the acceptability of one or more of the proposed design criteria.

The invention also relates to a computer-based dental restoration system comprising  
25 a network server having a database storing information about materials, procedures and preparations concerning dental restoration prosthesis; a communications network providing access to the network server; and one or more computers at a dental office accessing information stored at the database over the communications network and displaying the information in a humanly readable format. Preferably, the communications network is the  
30 Internet, and the information stored in the database comprises preparation diagrams, reduction dimensions, margin design and burs for specific dental restoration prostheses.

Advantageously, the database further stores information concerning one or more patients having dental restoration needs. Also, the network server further comprises application programs for enabling users to query the database regarding specific materials  
35 or procedures concerning dental restoration prostheses for confirmation, verification, modification or evaluation of the same, with the one or more computers at the dental office

receiving answers from the database to such queries. If desired, a printer located at the dental office can be used to print these answers for use by the dentist in carrying out the treatment plan.

5 The dental restoration laboratory also includes at least one computer that has access to the network server and the computer(s) at the dental office over the communications network. Preferably, the system includes a digital camera for taking digital images of the patient's teeth that are in need of dental restoration and a communication link for transmitting the digital images to the computer(s) at the dental office. Also, the computer(s) at the dental office store these digital images and the communications network  
10 forwards the digital images to the database for storage therein.

#### BRIEF DESCRIPTION OF THE DRAWINGS

These and other aspects of the invention should be more apparent from the following detailed description and drawings in which:

15 FIG. 1 illustrates a shade analyzer system for capturing images in accord with a specific embodiment of this invention;

FIG. 2 shows a representative image captured by the system of FIG. 1;

FIG. 3 shows a representative image made up of pixels as captured by detector elements of the system in accord with the invention;

20 FIG. 4 illustrates processing of the image of FIG. 3 using pseudo-pixels, in accord with one preferred embodiment of the invention;

FIG. 5 shows an end piece constructed for use with the system in FIG. 1, for simultaneous processing of an actual tooth image and various reference tooth shades;

25 FIG. 6 illustrates a compression sleeve constructed according with a specific embodiment of the invention for capturing high-quality tooth images;

FIG. 7 illustrates a source-to-tooth illumination, for improved image capturing in accord with one embodiment of the invention;

FIG. 8 illustrates baffling and stray-light rejection within a sleeve in a specific embodiment of the invention;

30 FIG. 9 illustrates different pseudo-pixel imaging mechanisms, optionally dependent upon tooth shape characteristics, used in accord with the invention;

FIG. 10 illustrates a non-contact tooth imaging system, with stray light rejection, constructed according to a specific embodiment the invention;

35 FIG. 11 illustrates another embodiment of a non-contact tooth imaging system in accordance with the present invention;

FIG. 12 illustrates a digital image of a tooth;

FIG. 13 illustrates a system for reimagining a tooth;

FIG. 14 illustrates various tooth decay patterns and restorations that can be addressed in accordance with the present invention;

FIG. 15 is a schematic representation of the interactive network system of the invention.

FIG. 16 is a block-diagram of the configuration of the interactive network system of the invention.

#### DETAILED DESCRIPTION OF THE INVENTION

10 The present invention now provides an enhanced dental restoration network as a service for dentists. This network would be established via a computerized link between the dentist, the lab, and, optionally, the lab's databank of the most current information regarding materials, procedures, and other services such as preparation design and surveying for dental restoration prostheses such as caps, crowns, bridges, fillings and the  
15 like.

In a typical case, initial steps of complete examination and diagnosis of the patient's dental condition is by the dentist. This generally includes a basic periodontal examination, clinical exam, radiographs, screening for TMD, etc.. The dentist also creates a preliminary treatment plan for addressing the dental needs of the patient. When tooth capping or  
20 replacement is required, clinical pictures which can be taken and captured on a program and are forwarded to the lab. These pictures can be of the color of the patient's teeth, the preparation of a tooth for further treatment, or even of a temporary treatment which can be modified or enhanced before being finalized. The pictures can be taken in any one of a number of ways, as described in more detail below.

25 In this invention, an on-site advanced restorative system is provided where the dentist takes one or more digital images of the tooth prior to restoration, eliminates areas of decay in the image, and matches the shade of material to be used to restore the tooth based upon the digital images of the tooth prior to removal. In another aspect, the dentist takes digital images of the tooth after preparation and matches the shade of the material to be used  
30 in restoration based upon the remaining parts of tooth. These pictures can be forwarded by facsimile, direct computer link, or by e-mail to the lab for evaluation, along with the dentist's preliminary treatment plan.

After preliminary treatment plans are designed, and areas such as periodontal needs, decay excavation, endodontic concerns are addressed, the restorative needs are considered.  
35 If the treatment plan may include fixed prosthodontics (crowns and bridges), the clinical pictures are then forwarded to the lab. The doctor and technician assess the case together

prior to accessing the interactive dental restorative network ("the site"). An illustration of such a network is shown in Fig. 16 and described in more detail below. If the case involves only direct restorations, the dentist can go directly to the site.

If the dentist does not have access to the site but his lab does, the doctor could send  
5 pictures to the lab, the technician in turn could access the site, and consult back to the doctor giving restorative options as given by the site. This service would be rendered by the labs for dentists that are not comfortable or familiar enough with computers to do their own electronic processing and communication with the site.

The site would provide access for users to information on materials, procedures  
10 involved in using such materials such as preparation design, recommended burs to achieve such a preparation, recommended temporization materials, cements that should be used with that given material, instructions on how to use such a cement (i.e., conditions such as whether one should etch or prime, for how long, whether to dry it or not, to pre-cure it or not, etc.), and where to buy such materials. Alternatively, the lab could explain how it  
15 would provide such a service or who the dentist could contact to obtain such service. Beyond this, once the treatment is underway, the dentist could verify his preparation with the technician, if necessary, by sending digital images electronically for review prior to final impressions. For a more precise evaluation of the case in treatment, the dentist would scan his preparations and go to part of the site that would survey the teeth and assess reduction  
20 amount. This would typically be used in larger and more complex cases.

The site would offer a number of features for communicating dental restoration data to the dentist and technician. One of the most unique features of the site is that it is interactive. Rather than just being a databank of information for the dentist to review, the dentist would be led through a step by step procedure to determine the most appropriate  
25 restorative path to take. The site could be visited periodically to consider alternative procedures, different options or to just confirm that the previous recommendations are clear and are being followed. Although many dentists read articles and reports, and attend seminars to obtain the latest information, until there is a case in hand, a lot of that information is not applicable. By the time a given case corresponds to a case presented at a  
30 previous seminar, the dentist may have already forgotten the information. The present method and system provides immediate feedback of the most up-to-date information in real time for the specific need of the current patient.

As the dentist accesses the site, he can immediately be asked certain questions regarding the patient's history. Typical questions under consideration for dental restoration  
35 procedures include: Are esthetics a main concern? Is the patient a bruxer (i.e., heavy grinder)? What is the extension of the patient's smile - give the teeth numbers of the limits

of what is visible on their widest smile? Does the patient have a high lip line, i.e., does their lip lie below the incisal edge, midtooth, at the cervical margin, above the cervical margin? Do they show mandibular (lower) teeth when they smile? Is the opposing occlusion natural? If not, is it metal, porcelain, amalgam, composite or denture teeth? By providing  
5 the restoration lab with this additional information, all factors can be considered so that a sound, tailored treatment plan can be confirmed or recommended.

The laboratory then would consider the teeth in question: Are they anterior or posterior? Endodontically treated or vital? What shade are they initially? What is the desired shade? What is the prepared tooth shade? (Information on how to obtain the color  
10 of the teeth is disclosed in the other application - please insert here) What are the dimensions of the tooth - is it a short clinical crown, or average to larger than average in size? Are there any implants involved? The process would operate like an "elimination tree" - if the first question of esthetic concern was a "no", the site would not go on to ask smile dimensions and such. All questions would be answered to a point to compile a  
15 profile, and any given patient may require their case to be divided into more than one profile depending on the scope of their needs, say corresponding to sections of their mouth in quadrants.

Another issue to be addressed is that of materials. This would give the material name, its characteristics and properties, and why it was suggested. Suggested is the  
20 operative word here because it should be understood that ultimately it is the dentist's choice of treatment modality that is used and not that of the technician or the site. After the dentist chooses the material, he would need to know where to obtain it, if he didn't already have access to it. This would entail the dentist purchasing a direct material, either through the site to an ordering area, or being referred to a lab in his area that uses such a system.

25 The issue of preparation design when planning to use that given material is also addressed by the site. Different materials demand different substructures and margins. There are not a tremendous number of different designs needed. Within the site, there is a file of preparation diagrams, which could be printed out by the dentist, if necessary, to provide reduction dimensions, margin design and the burs needed to do this. This would  
30 include bur name and number, type and where to obtain them. Once again, the dentist may order this through the site or obtain information or where it could be purchased in his area. The dentist could simply obtain all materials from the site compile a shopping list for this particular procedure and go out and obtain the materials on his own.

Once the case is underway, and the initial preparations are completed, the dentist  
35 could go back to the site and scan the preparations to assure compliance. Alternatively, digital representations of the preparations could be sent back to the site or lab for their



further review. A of the preparations can also be made by accessing a survey area of the site. This would evaluate the preparation for undercuts, under-reduction, margin extension, and highlight areas that needed to be modified for optimum results.

5 Communication with the site in real time would save a great amount of time and effort. By first confirming that the preparations and recommended dental restoration procedures are correct, the lab would not have to be pouring and working on models of a case that were not useable because the preparations required changing. Also saved would be the time of having the patient return to the office on multiple occasions for refining preparations. This is a significant benefit for both dentist, patient and laboratory. By 10 providing the laboratory operator with such information without taking an impression, pouring up models and surveying them with a traditional surveyor, both time, materials and expenses due to re-work are saved.

Another advantage of real time evaluation is reduction. One of the most common errors in preparation is under-reduction (i.e., not removing enough tooth structure to allow 15 room for the materials that will make up the crown or restoration), which causes either too thin of restoration in that area which can lead to future failure, or repreparation (i.e., more wasted chair time) and new impressions or reduction copings. Within the survey site, the dentist would be able to more accurately scan the preparation with the teeth in occlusion so as to measure the amount of reduction to the tenth of a millimeter. Then, the dentist would 20 compare this measurement to the given specifications of the preparation he had retrieved earlier from the preparation design area of the site to confirm compliance.

Another use of the present interactive dental restoration network is the verification of the final dental prosthesis before it is permanently placed in the patient's mouth. For example, when a crown is finally prepared, digital images can be taken and compared to the 25 digital images of the patient's teeth that were previously obtained to assure that the closest color match has been achieved. Any necessary color corrections can be made by the laboratory or the technician before permanent placement of the crown. This again saves time by avoiding rework when the patient returns to the dentist's office for the installation of the crown.

30 A number of different aspects of determining tooth shade color are disclosed. For clarity of presentation, these aspects are organized and described below in sections which are not intended to be limiting in any way.

### **The Color Determination Method**

With reference to Fig. 1, a solid state camera 12 (e.g., a CCD camera coupled to a PC board, or an intra-oral camera) is utilized to capture one or more images of each known conventional tooth shade. Tooth shades used to this end may correspond, for example, to the VITA™ Shade guide, or a shade guide corresponding to a porcelain by another dental products manufacturer. By way of example, a first series of images taken in accordance with the invention corresponds to sequential images of the A1 shade by Vita, a second series of images corresponds to sequential images of the A2 shade by Vita, and so on. In accordance with the invention, captured image series of the known 7 tooth shade guides are properly labeled and then stored onto the hard disk of the computer, or other suitable storage device for further analysis. FIG. 2 illustrates a representative digital image 30 captured by the camera 12.

As known in the art, each digital image has a plurality of picture elements, i.e., “pixels”, corresponding to the elements of the solid state camera and representing the light intensity and color properties of a given spatial location on the tooth. The distance between adjacent pixels in the image is determined by the spatial resolution of the camera. For example, an image of a tooth shade (or a human tooth) can be made up of 300 pixels in width across the tooth and 350 pixels in height. In human teeth, any given tooth is approximately the same size, give or take a couple of millimeters, for all people. For example, most central incisors usually measure between 9 - 11 mm in width, and somewhat greater in length. It is clear therefore that for a given spatial resolution of the camera, in accordance with this invention an image of a tooth can be taken knowing the approximate number of pixels corresponding to the tooth in the image. Thus, in the example above, 1 mm of the tooth width may be represented by 30 pixels. It will naturally be appreciated that the tooth image is typically not rectangular, and that pixels at the corners of an image may correspond to the background (i.e., the region outside of the tooth) and not of the tooth or tooth shade. See FIG. 2 for further illustration.

As indicated above, a single digital image can be captured for each tooth shade or actual tooth. Those skilled in the art will appreciate, however, that taking a series of images per shade is preferable, since it reduces the risk of image anomalies, as explained in further detail below.

Next, each image or each image in a series is processed into a “pseudo” reference image (hereinafter PSEUDO IMAGE) made up of pseudo-pixels. As used in this disclosure, pseudo-pixels correspond to groups of pixels covering specific areas (i.e., rectangular or square) of the image plane. FIG. 3 shows a blow up image of the pixels (only representative pixels are shown) which make up the tooth image 40 of FIG. 2. In

accord with the invention, these pixels are transformed into pseudo-pixels 44, as shown in FIG. 4. In the embodiment illustrated in FIG. 4 each pseudo-pixel 44 is made up of all real pixels within the area of the associated pseudo-pixel. Pseudo-pixels 44b shown in the figure illustrate, for example, how a pseudo-pixel can be generated from nine real pixels 42.

5 FIG. 4 also illustrates that an image can be made from either a real tooth 40 (resulting in a REAL IMAGE) or a reference shade 40 (resulting in a REFERENCE IMAGE).

FIG. 9 shows how pseudo-pixels can be arranged in a preferred embodiment in different patterns, automatically, depending upon which tooth is imaged. For example, an incisor 200 can have an arrangement of pseudo-pixels 202, as shown in the left-hand  
10 example, while a molar 204 can have an arrangement of pseudo-pixels 206, as shown in the right-hand example. With further reference to FIG. 1, such arrangements can be made automatically in the system of this invention by informing the computer 14, and hence the software 50, to apply pseudo-pixels in the appropriate pattern. Such arrangements assist in overall processing by ensuring appropriate pseudo-pixel placement. As illustrated in FIG.  
15 9, pseudo-pixels need not be contiguous, or aligned, such as shown by the arrangement of pseudo-pixels 206.

In a preferred embodiment, the intensity and color associated with a pseudo-pixel are computed or otherwise formed as an average (or other statistical measure) of the actual pixels forming the pseudo-pixel. By way of example, if an actual image taken in the first  
20 step of the method corresponds to a rectangular tooth that is digitized at 300W by 350H resolution, i.e., having a total of 300x350 elements, in accordance with this embodiment one can create pseudo-pixels such as 6W by 7H, with each pseudo-pixel being formed as a statistical measure of the 50x50 pixels within the pseudo-pixel (resulting in 42 pseudo-pixels representing the entire tooth).

25 As noted above, in accordance with a preferred embodiment, pseudo-pixels are generated by data derived from the actual pixels located within the pseudo-pixel. For example, in a specific embodiment one can average the red, green and blue (RGB) components for each of the 2500 pixels within each pseudo-pixel to determine a reference RGB for that pseudo-pixel. Those skilled in the art will appreciate that other statistical  
30 measures or characteristics can be used, such as the mean "hue" measure of the pixels within a pseudo-pixel, or others. For example, the RGB pixel values may be converted into the Hue, Saturation and Intensity ("HSI") color space by using known algorithms, such as the Gonzalez and Woods method, as follows:

R = Red value for pixel

G = Green value for pixel

B = Blue value for pixel

Intensity =  $1/3 (R + G + B)$

5 Saturation =  $1 - (3 / (R + G + B)) * \text{Min}(R, G, B)$

Hue =  $\text{Cos}^{-1} ( (0.5 * ((R - G) + (R - B))) / ((R - B) * (G - B))^{0.5} )$

If S = 0, Hue is meaningless

If  $(B/\text{Intensity}) > (G/\text{Intensity})$  then Hue =  $360 - \text{Hue}$

Since Hue is an angle in degrees values were normalized to 0.1 with Hue = Hue/360

10 As known in the art, the RGB color space can be represented as a simple cube, with R, G and B emanating from one corner along three perpendicular edges. The origin corner (0,0,0) is black, and the opposite corner (1,1,1) is white. All points along this line from corner to corner are shades of grey. The HSI color space is this same cube stood on the origin corner, with the Black White line being vertical. The black - white line is the  
 15 intensity axis, the hue is given by an angle from the intensity axis and the saturation is the distance from the intensity axis to the color point (i.e., the radius). The new VITAPAN 3D-Master Shade system uses an L\*a\*b\* Color Sphere to determine tooth shades based on Value, Chroma and Hue. It is possible to convert the RGB values to this color system, if necessary or desired.

20 In accordance with a preferred embodiment, PSEUDO IMAGES corresponding to series of images are processed then into a "REFERENCE IMAGE". By way of example, the REFERENCE IMAGE is generated as an average (or other statistical measure) of the PSEUDO IMAGE series of images of the VITA™ A2 shade guide. The measure in this example is obtained by averaging the R, G, B components for each pseudo-pixel of the A2  
 25 PSEUDO IMAGE series to determine an average RGB value for a pseudo-pixel of the REFERENCE IMAGE. In alternative embodiments operating in the HSI color space, the corresponding average values can also be determined for each pseudo-pixel of the PSEUDO IMAGE series; and, for example, an average hue (or other statistical measure of hue) can also be associated with each pseudo-pixel in the REFERENCE IMAGE. Those skilled in  
 30 the art will appreciate that other color characteristics can be used alternatively or in conjunction with the measure of RGB and/or hue. It will be appreciated that if only one PSEUDO IMAGE is made per shade, than that PSEUDO IMAGE defaults as the REFERENCE IMAGE since no other statistical combination is available.

It should be noted that forming of pseudo-pixels is not a requirement for practicing  
 35 this invention. However, pseudo-pixels are used in a preferred embodiment because they may reduce the processing load of the system, minimize storage requirements and also

because they can simplify the task of aligning corresponding pixels from different images. Proper pixel alignment is important in order to ensure the integrity and accuracy of the statistical averages used in the formation of REFERENCE IMAGES. In this regard it will be appreciated that it is generally difficult to precisely align all pixels in several images  
5 taken from the shades of the same shade guide, unless there is extremely good control utilized in the image capture sequence. Using pseudo-pixels in accordance with the preferred embodiment reduces the total number of pixels per image and thus simplifies the task of aligning different images accurately.

Pseudo-pixels are even more important in later steps of the processing method of  
10 this invention. That is, although one has complete freedom to set up the optics and the camera, which together determine the magnification of a captured tooth shade (or tooth) image, when trying to "match" a REFERENCE IMAGE to an actual digital image of a patient's tooth, the actual image (hereinafter referred to as a SNAPSHOT) may be quite different in shape and size (either real size or apparent size due to magnification differences  
15 in the optics or camera CCD element size). As such, a "one-to-one" comparison between the SNAPSHOT and the REFERENCE IMAGE is difficult. Pseudo-pixels help in this respect because the SNAPSHOT can be scaled to approximate the REFERENCE IMAGE size, or vice versa; and the SNAPSHOT can also be processed into pseudo-pixels. The scaled and pseudo-pixel version of the SNAPSHOT image is denoted as the "REAL  
20 IMAGE" hereinafter. Pseudo-pixels used in a preferred embodiment thus permit a convenient mechanism for comparing a REFERENCE IMAGE to a REAL IMAGE.

In accordance with a preferred embodiment, the generation of each REFERENCE IMAGE preferably includes a "bad pixel" routine where each pseudo-pixel in the PSEUDO IMAGE series is analyzed for bad pixels. A "bad pixel" means any real pixel  
25 corresponding to a defective CCD element or corresponding to an area with an unwanted artifact, e.g., reflection, in the digital image, or an area that contains "background" imagery (e.g., any pixel image not corresponding to the tooth or tooth shade). Any pseudo-pixel in the PSEUDO IMAGE which contains a bad pixel is preferably not utilized in the generation of the REFERENCE IMAGE. That is, if for example a REFERENCE IMAGE is made up  
30 as an average of three PSEUDO IMAGES, and yet one pseudo-pixel in one of the PSEUDO IMAGES contains a bad pixel, then in a specific embodiment the resulting pseudo-pixel of the REFERENCE IMAGE is either discarded, or computed only as an average of the other two associated pseudo-pixels of the PSEUDO IMAGES.

Note that the bad pixel routines are particularly important at the edges of the image  
35 of the tooth or tooth shade. Consider, for example, the shape of the tooth 40 in FIG. 3 or the irregular shapes illustrated in FIG. 14. Clearly, such shapes are not rectangular, and

thus creating pseudo-pixels in accordance with the preferred embodiment will result in certain pseudo-pixels having bad pixels at the image edge. FIG. 4 illustrates bad pseudo-pixels 44a that contain pixels 42a, which are not part of the tooth image 40. Bad pixel routines used in accordance with a preferred embodiment to detect such pixels and

5 disqualify them from further processing. For example, if 5% or more of the pixels within a pseudo-pixel are "bad" (e.g., containing reflections or other unwanted data), then such pseudo-pixels are disqualified. Though not shown, other pseudo-pixels might be disqualified if for example reflections from the light ports cause unwanted reflections in the other pseudo-pixels image 40. In a preferred embodiment, such pseudo-pixels are deleted

10 from inclusion in the REFERENCE IMAGE.

In a specific embodiment, the bad pixel routine need only be implemented when capturing and generating REAL IMAGES. In that process, conditions such as lighting and other variables can create unwanted artifacts that should be eliminated from processing. In addition, when cameras are used in the field, one pixel might become defective over time;

15 and REAL IMAGES later generated from the defective camera should be adjusted so that the pseudo-pixel which contains the bad pixel is not counted or utilized.

In another aspect, areas of the tooth for which the color is to be evaluated are predefined, allowing the analyzer program operating in accordance with this invention to batch-process the images. For example, a sample image can be loaded into an Area

20 Selection Editor program module, where adjustments can be made to user-selected (or predefined) areas of the tooth image. These defined areas are then applied to each image in turn, and the pixel colors within each area are analyzed. In operation, following the image capture in one embodiment the method of this invention proceeds to automatically select the area(s) of the sample for analysis, for example, by applying a general rule to locate the

25 edges of the tooth in the image, and apply a predefined segmentation of the remaining area for analysis. Preferably, the user is allowed to manually select an area of interest in the image, for example, using a computer mouse, as known in the art.

In accordance with one embodiment, following the detection of the correct areas for analysis (i.e., excluding edges, light reflections and others), the selected area is divided by

30 using, for example a grid overlay, as shown in Fig. 9. As known, each shade has a varying color content from top to bottom. Therefore, in accordance with this embodiment a more accurate analysis of the entire surface of interest can be made if color determination and matching is applied to the individual cells of the grid, as compared with corresponding area cells of the stored color reference model for each shade guide.

35 Following this stage, in a preferred embodiment before analyzing the area, various filtering operations can be applied to the image, as known in the art. For example, filtering

is applied to eliminate abnormalities such as lamp reflections or dark spots. In addition, maximum, minimum and average values for the R, G and B components can be determined over the area of interest and used to, for example, limit the variation from the average value to half way to the maximum and minimum values. This simple filtering operation has  
5 shown satisfactory results in actual testing, although alternative or additional filtering operations can be applied, as known in the art in order to obtain a standard image.

In the next step of the method, a SNAPSHOT of a patient's tooth is taken by the camera. Next, the digital image of the SNAPSHOT is scaled, if necessary, to approximate the size of the corresponding REFERENCE IMAGE. In the preferred embodiment using  
10 pseudo-pixels SNAPSHOT pixels are next processed into pseudo-pixels resulting in a REAL IMAGE containing pseudo-pixels, which substantially correspond to REFERENCE IMAGE pseudo-pixels. A bad pixel routine preferably processes the REAL IMAGE to delete REAL IMAGE pseudo-pixels containing a bad pixel. As above, the bad pixel routine is particularly important at the edges of the tooth image within the SNAPSHOT, where  
15 some pixels will certainly contain background (unless the camera and optics are arranged to capture only the tooth; however this is not efficient since effective matching between the REAL IMAGE and the REFERENCE IMAGE occurs when a larger area of the tooth is used in the comparison algorithms, which are defined in further detail below.

In a subsequent step, the REAL IMAGE is compared (i.e., correlated) to each  
20 REFERENCE IMAGE in the database (e.g., there could be sixteen REFERENCE IMAGES corresponding to the A1-A4, B1-B4, C1-C4 and D2-D4 Vita Shades) via the correlation algorithm (hereinafter "Correlation Algorithm") described below. In this step, each pseudo-pixel of the REAL IMAGE is compared to each pseudo-pixel of the REFERENCE IMAGE; and a composite match number ("CMN") is created indicating how well the REAL IMAGE  
25 matches to that REFERENCE IMAGE. The composite match numbers are compared to one another and one of the REFERENCE IMAGES is selected as the "best fit" match to the REAL IMAGE.

There is potentially a problem associated with the bad pixel routine and subsequent correlation between REAL IMAGES and the series of REFERENCE IMAGES. As  
30 described above, in a specific embodiment, when there is a bad pixel in any pseudo-pixel, all other pseudo-pixels of the same spatial location are discarded. This can become a problem in a case when every (or even most) pseudo-pixel is disqualified, resulting in a situation where no meaningful comparison can be made. Accordingly, in a preferred embodiment, images are correlated on the basis of mathematical measure, i.e., an average,  
35 that is functionally dependent upon how many pseudo-pixels remain in an image (REAL or REFERENCE). That is, for any given correlation between a REAL IMAGE and a

REFERENCE IMAGE, the number of pseudo-pixels for that comparison are used as a ratio for comparison to other correlation. This aspect of the invention is described in more detail below.

In an alternative embodiment, the averaging technique discussed above is used only when, for example, more than 20-25% of the pseudo-pixels are disqualified for all comparisons. Accordingly, so long as there is a sufficient number of remaining pseudo-pixels for comparison, a direct comparison of these pixels can be made without resorting to averages. In a specific embodiment, a sufficient number is deemed to be about 75-80% of the total number of pseudo-pixels available for comparison. Other ratios can be used in alternate embodiments.

Bad pixel routines are generally known in the art and thus need not be described in much detail. It is sufficient to note that in accordance with this invention a pixel is determined to be "bad" if its light intensity or color values deviate by more than a certain predefined percentage from adjacent pixels known to be "good". For example, if a pixel deviates by more than 30% from the light intensity of the neighboring 8 pixels, there is a good likelihood that this deviation is anomalous, i.e., due to a bad camera element or corresponding to an image border, and has to be discarded.

In a preferred embodiment, a pseudo-pixel is validated only when it contains less than a certain percentage, i.e., about 5%, bad pixels of the total pixels making up the pseudo-pixel. Preferably, bad pixels are also not used in the statistical characterization (e.g., RGB) of the pseudo-pixel. Accordingly, in this embodiment if more than about 5% bad pixels exist for a pseudo-pixel, the pseudo-pixel is not used in further processing.

#### Correlation Algorithms

In a preferred embodiment, the Correlation Algorithm of the present invention operates as follows. Each REFERENCE IMAGE is actually a matrix of vectors, each vector corresponding to a pseudo-pixel. By way of example, the REFERENCE IMAGE corresponding to the Al Vita Shade can be assigned as vector  $Z_{A1}$ . For the sixteen Vita Shade guide, the remaining fifteen shades for example each have a REFERENCE IMAGE too, e.g.,  $Z_{A2}$ ,  $Z_{A3}$ , etc.

Each REFERENCE IMAGE vector "Z" - corresponding to shade guide or porcelain "X" - thus has data similar to the following matrix:



5

$$Z_x = \begin{vmatrix} PP_{x,1} \\ PP_{x,2} \\ PP_{x,3} \\ \dots \\ PP_{x,n} \end{vmatrix} = \begin{vmatrix} R_{x,1} & G_{x,1} & B_{x,1} \\ R_{x,2} & G_{x,2} & B_{x,2} \\ R_{x,3} & G_{x,3} & B_{x,3} \\ \dots & \dots & \dots \\ R_{x,n} & G_{x,n} & B_{x,n} \end{vmatrix}$$

10 where each of the pseudo-pixels "PP" has three values for each of R, G and B values of the pseudo-pixel (actually, the RGB values are the statistically computed (e.g., averaged) composition of the images in the series for that REFERENCE IMAGE, if available). The subscript "x" refers to the appropriate shade, e.g., "A1". Subscripts 1-n define separate pseudo-pixels in the REFERENCE IMAGE. Those skilled in the art will appreciate that  
 15 additional, other or different data can make up each vector, including hue data for each pseudo-pixel. Additionally, other vectors can be considered and processed in the correlation, such as hue and RGB values.

In a typical example, each REFERENCE IMAGE might have 20x20 pseudo-pixels which define the REFERENCE IMAGE. Therefore, "n" in the above matrix is 400.

20 When a REAL IMAGE "I" is generated, in accordance with this invention it too is arranged as a matrix of similar form, with each pseudo-pixel "PI" of the REAL IMAGE being a vector of RGB form (or, like above, containing other or additional factors such as hue):

25

$$I = \begin{vmatrix} PI_{x,1} \\ PI_{x,2} \\ PI_{x,3} \\ \dots \\ PI_{x,n} \end{vmatrix} = \begin{vmatrix} R_{i,1} & G_{i,1} & B_{i,1} \\ R_{i,2} & G_{i,2} & B_{i,2} \\ R_{i,3} & G_{i,3} & B_{i,3} \\ \dots & \dots & \dots \\ R_{i,n} & G_{i,n} & B_{i,n} \end{vmatrix}$$

30

In a specific embodiment, the Correlation Algorithm used in accordance with the present invention computes a measure of closeness, i.e., a composite match number  
 35 ("CMN") through the following relationship:

$$CMN_x = \sum_{q=1}^n \sqrt{(Z_{x,q} - I)^2} = \sum_{q=1}^n \sqrt{(PP_{x,q} - PI_q)^2}$$

or

5

$$CMN_x = \sum_{q=1}^n \sqrt{(R_{x,q} - R_{i,q})^2 + (G_{x,q} - G_{i,q})^2 + (B_{x,q} - B_{i,q})^2}$$

Once the CMN number is computed for each tooth shade, as shown in the example  
 10 above, a search is then conducted for the lowest  $CMN_x$  to find the best fit REFERENCE  
 IMAGE for the REAL IMAGE. That is, the tooth shade or porcelain "X" is identified for  
 the lowest associated value of CMN. As noted above, if there is more than a certain  
 percentage of bad pixels in any pseudo-pixel q for either the REFERENCE IMAGE or the  
 REAL IMAGE, in a preferred embodiment that pseudo-pixel is not used in the valuation of  
 15 CMN. For example, in accordance with the present invention it is acceptable to determine  
 CMN without the q-th pseudo-pixel; however, every other concurrent q-th pseudo-pixel  
 valuation of  $CMN_x$  in identifying the composite match number is also discarded, so that  
 CMNs for all tooth shades can be compared correctly.

As noted, the Correlation Algorithm of the embodiment illustrated above preferably  
 20 uses a bad pixel routine to disqualify bad pseudo-pixels. It was noted already that this can  
 create problems in certain situations. Accordingly, in a preferred embodiment, the  
 following alternative algorithm can instead be used:

25

$$CMN_x = \sum_{q=1}^n \sqrt{\left(\frac{R_{x,q} - R_{i,q}}{Pcount_x}\right)^2 + \left(\frac{G_{x,q} - G_{i,q}}{Pcount_x}\right)^2 + \left(\frac{B_{x,q} - B_{i,q}}{Pcount_x}\right)^2}$$

In this embodiment for the computation of  $CMN$   $Pcount_x$  corresponds to the number  
 of common pseudo-pixels found between the REAL IMAGE and the vector  $Z_x$ . Note that  
 $Pcount_x$  can be different for each CMN correlation. For example, if the REAL IMAGE has  
 30 400 pseudo-pixels, all good, and REFERENCE IMAGE for A1 has 399 pseudo-pixels (e.g.,  
 one bad pseudo-pixel identified in the bad pixel routine), then  $Pcount_{A1}$  is 399. If however  
 the REFERENCE IMAGE for B4 has 256 pseudo-pixels, then  $Pcount_{B4}$  is 256. If in the  
 same example the REAL IMAGE has 256 valid pseudo-pixels - and in the unlikely event  
 that the disqualified REAL IMAGE pseudo-pixels overlap with the coordinates of  
 35 disqualified pseudo-pixels in the REFERENCE IMAGE - then  $Pcount_{B4}$  is still 256;  
 however  $Pcount_{A1}$  is also 256 (assuming that the one bad pixel of REFERENCE IMAGE A1

corresponds to one of the disqualified pseudo-pixels in the REAL IMAGE. If the one bad pseudo-pixel in REFERENCE IMAGE A1 does not correspond to coordinates of one of the disqualified pseudo-pixels of the REAL IMAGE, a more likely event, then  $Pcount_{A1}$  is also 255.

5 Those skilled in the art will appreciate that isolating the measure of closeness CMN in one of the above equations can also be determined without the square root operation - as a minimum composite match number will still be identified for the same functional conditions and/or data.

In accordance with the specific embodiment described above, the process of  
10 determining  $Pcount_x$  can be made at any point. In a preferred embodiment, this process is initiated only after a certain percentage of pseudo-pixels are disqualified. For example, if after the completion of the bad pixel routine there remain 300 pseudo-pixels for comparison (in the example that 400 pseudo-pixels exist in each of the REFERENCE and REAL IMAGES), then a straight comparison can be made without the use of the  $Pcount_x$   
15 adjustment, because a significant percentage of the images can be compared (defining 75% as "significant"; other percentages can be used). Note that it is likely that many of the bad pixel areas in images will overlap, such as at the edge of the image, where tooth shape variations occur often, and at locations such as reflection areas (e.g., areas which specularly reflect light energy to the camera), which are likely to be similar given that the illumination  
20 source is generally fixed for each image acquisition.

Those skilled in the art will appreciate that variations to the above-described methodology may occur without departing from the scope of the invention. For example, other color detection techniques can be used to characterize tooth color within a pseudo-pixel. In one example, colorimetric "laser-diode" measurements can be used to generate a  
25 reflection trace for each pseudo-pixel. In such measurements, a laser diode is "scanned" in wavelength so that a laser beam, scanned through a range of wavelengths, reflects off of each pseudo-pixel. This spectrophotometric-like trace information (for example containing reflectance per wavelength) can be collated with other such traces for other pseudo-pixels to generate a vector of such information. As above, correlation between real and reference  
30 vectors is used to determine a best-fit color match.

In accordance with another embodiment of the present invention, the camera used for capturing images has a focal plane array with fewer detector elements as compared to typical high resolution arrays (for example those arrays with 640x480 elements, or megapixel digital cameras). For example, in one embodiment of the invention an array has  
35 a relatively small number of detectors, i.e., 20x20, 60x40 or others. Such a camera can alleviate the need for pseudo-pixels, as defined above, since each real pixel generated from

each detector covers a relatively large area of the tooth image. In effect, such a camera generates "pseudo-pixels" in each digital frame image. Since fewer detector elements are used in this embodiment, it will be appreciated that the camera's overall cost can be reduced. Those skilled in the art will appreciate that a similar effect may be obtained in an alternative embodiment by using magnification optics that only utilizes a small portion of the camera's array in obtaining the image; however such an approach wastes pixel information which has already been collected.

Those skilled in the art will appreciate that other closeness measures can be used instead of the algorithms described above to achieve a similar result. By way of example, other techniques of measuring similarity between two data sets can be used in determining a measure of how similar or close two data sets are. For example, one can arrange a data set as a vector so that the correlation coefficient is determined as the cosine of the angle between data vectors. Cross-correlation functions or matched filtering can also be used beneficially. The interested reader is directed to any number of books on digital image and signal processing, such as, for example, Netravali and Haskell, "Digital Pictures, Representation and Compression," Plenum Press, 1988. Sections 1.1; 1.2; 1.3; 1.8; 1.9; 2.2; 3.2; and 3.3 of this book are incorporated herewith by reference for background purposes.

In still another embodiment, the shape of the grid of pseudo-pixels defining each tooth is selected in a manner dependent upon how the tooth is positioned in the mouth. For example, an incisor tooth very nearly maps to a shade guide; however, with reference to Fig. 14, a posterior tooth does not, particularly relative to the image capture position of the camera. Further, it will be appreciated that for purposes of improving the appearance of a smile, anterior teeth are considerably more important than those in the posterior of the mouth. Thus, in a preferred embodiment it is desirable to provide more close matches, and correspondingly more dense and accurate grid patterns for the anterior teeth. Accordingly, in a specific embodiment, grid shapes and correlation algorithms can depend upon tooth orientation within the mouth and/or upon generalized tooth shape. In particular, anterior teeth will have a (proportionately) larger number of pseudo-pixels than teeth in the back of the mouth for the same surface area.

An image of a tooth or tooth shade may be analyzed by a flood fill algorithm to find the edges of the target tooth or tooth shade. Using this algorithm, from a point in the image (e.g., in the SNAPSHOT) known to be in the tooth or tooth shade, adjacent pixels are considered only if that pixel is in a valid color range. The maximum extent is then recorded for the search in the X and Y directions, forming the outer limits of the grid. In addition, contrast changes in groups of pixels can be considered and used to determine the extent; but a black border is easy to find.

In accordance with another important embodiment, "tooth shades", as used above, are not used per se in defining a patient's tooth color. Rather, in a specific embodiment, a grid of pseudo-pixels is generated for the patient's tooth; and these (pseudo-)pixels define the porcelain for respective regions of the tooth. Pseudo-pixels are not actually required; and actual pixels can also be used in this manner to define porcelain characteristics for each spatial location in the mouth. Reconstructive tooth material is then specified per pixel or pseudo-pixel. A data file generated from the SNAPSHOT or REAL IMAGE is then processed to specify reconstructive materials with spatial precision, as defined by pixels or pseudo-pixels. An acceptable quantification of RGB values, for example, can be used to tolerance both the measurement and materials specification. For example, by associating error bars with each measure - e.g.,  $R \pm \Delta R$ ,  $G \pm \Delta G$ ,  $B \pm \Delta B$ , where the  $\Delta$  quantities are defined within certain practical tolerance limits - reasonable tolerances can be achieved. Tooth shades operate similarly in that each shade results in a quantized color difference from every other shade; and thus the aforementioned tolerancing technique provides similar accuracy to the above-described correlation algorithm. Unlike the tooth shade approach, however, spatial accuracy for any given reconstructive tooth is generally determined only by the number of pixels or pseudo-pixels used in the reconstructive tooth manufacture; whereas a tooth shade has predefined color gradients defining the tooth shade regardless of the numbers of pixels or pseudo-pixels used. It will be appreciated that this approach avoids the use of tooth shades at all, along with the possible confusion created by the existence of alternate tooth shade guides.

### **The Color Measuring System and its Components**

Cameras of the type required for use with this invention are generally known in the art and include, for example: INSIGHT™, manufactured in San Carlos, California; CYGNASCOPE™ offered by Cygnus Instruments, Inc., Goleta, California; VISTACAM™ and others. In a preferred embodiment, the system of this invention uses a Welch-Allyn brand camera. Generally, it is desired to use camera systems offering full-color imagery, which are capable of capturing a range of sizes, i.e., from the size of a typical patient's tooth preferably to images of the patient's whole smile.

In the preferred embodiment, it is advantageous for the camera to supply a minimum 640 x 480 pixel image to the PC software 24 bits per pixel (i.e., 8 bits for each of the red, green and blue (RGB) components), or preferably 30 bits per pixel. In a specific example, the system of this invention uses ALARIS QUICK VIDEO TRANSPORT frame grabber, providing digitized images with at least 24 bits resolution. More specifically, the software can use a Twain protocol interface, as known in the art, which allows other cameras and

frame grabbers to be tested without the need for a change of software. Preferably, images captured by the camera are displayed on a monitor screen to provide instantaneous feedback to the system operator.

In another preferred embodiment, the resolution of the camera is specified in terms of the Minimum Resolvable Color Difference that the complete system is able to achieve. This can be specified, for example, as the two RGB values of the two closest shades the system is required to differentiate. For example, the Chromoscop Shades 430 and 440 can be used to this end. In general, it is envisioned that the system should be able to differentiate between about 80 or more different shades. Another requirement is that the system should be able to produce repeatable images. That is to say that images of the same tooth taken at the same session should not have a  $\Delta i$  of not more than 0.1, which is the amount needed for the eye to perceive a difference. In a specific embodiment, the camera used in the system of this invention is a CMOS imager.

In terms of its physical setup, a stand-alone camera containing its own light source can be used, as explained below. A number of alternate embodiments are available in this regard. For example, in one embodiment the camera can be battery powered. In this embodiment, the camera can sit on a holder containing an inductive battery charger when it is not in use. In another embodiment, when mounted on the charger the camera can be coupled via an isolation sleeve (to be explained below) to a calibration target, for example, made of porcelain.

In a specific embodiment the output of the camera is supplied to a digitizer (such as a Sony digitizer) enabling convenient digital storage of the image. As noted above, the output of the camera can also be supplied to a frame grabber in a PC. Both options can be used in a specific embodiment. In another embodiment, the output of the camera can be supplied directly to a monitor (preferably positioned close to a surgery chair) and provide a digital output to a PC, which then need not be close to the patient. As known in the art, the output could be USB-type, or IEEE 1394.

In accordance with a preferred embodiment the digital output of the camera also provides the opportunity to control the camera from a PC. Finally, in a preferred embodiment it is desirable to control the camera so as to use it in two modes, i.e., normal image – for the mouth and full face shots; and analysis image – in which color balance and automatic functions are disabled for tooth and calibration image, as described below.

Turning now to the drawings, FIG. 1 shows a system constructed according to a preferred embodiment of the invention. A solid state (or intra-oral) camera 12 connects to a computer 14 via a PC card 16 to capture images through a wand 18. The solid state camera

12 includes a detector array 12a including an array of detector elements 12b, which generate pixels in the digital images (e.g., SNAPSHOTS) captured by the camera 12.

Through one of several known mechanisms, internal optics within the wand 18 and/or camera 12 permit the capture of an image of a target object 20 (for purposes of illustration, target object 20 is shown grossly over-sized as compared to other elements in FIG. 1) by the array 12a. By way of example, relay optics 18a within the wand relays an image to the array 12a. A protection sleeve 22, discussed in further detail below (also grossly oversized for purposes of illustration), preferably extends from the wand 18. As shown, the optics provide an optical conjugate between the array 12a and the target object 20 through well-known imaging techniques. Light captured from the target object 20 enters the wand 18 for transfer to the camera 12 through an entrance aperture window 26.

The wand 18 generates light 19 to illuminate the target object 20 through light ports 28. Preferably, light from the outside 30 of a sleeve 22 is not permitted to illuminate the object 20 so that control is maintained; and thus the sleeve 22 shields the target area 20 from illumination by outside sources 30 (e.g., ambient room lighting).

An aperture 32 within the center of the end piece 34 of the sleeve 22 is where the tooth or tooth shade are placed so that a SNAPSHOT (i.e., a digital image of the tooth or tooth shade) can be made. As discussed above, these SNAPSHOTS are processed to form REAL IMAGES (from real teeth) or REFERENCE IMAGES (from tooth shades or porcelains, etc.).

A black border 36 around the aperture 23 provides a good reference around which the tooth or tooth shade are discernible within the digital image of the target area 20. The remaining area 38 about the border 36 and within the end piece 34 is preferably a white reference sample, equally reflecting all light 19 from the light ports 28.

Finally, again with reference to FIG. 1, digital images from the camera 12 are sent to the computer 14; and processing software 50 within the computer 14 processes these images to generate, i.e., a CMN for each REAL IMAGE relative to the REFERENCE IMAGES. As discussed above, the software 50 processes the CMNs to locate the lowest value CMN, indicating a match; and communicates the associated shade of that lowest CMN to the user via signal line 52. As mentioned, other processing algorithms can be developed to determine a best-fit match without departing from the scope of the invention.

A representative digital image 30 captured by the camera 12 is illustrated in FIG. 2, showing an image 36' of the border 36, an image 38' of the reference sample 38, and a tooth image 40. The entire image 30 covers the target area 20 of FIG. 1. FIG. 2 also illustrates obvious regions 41 of the image 30 that would generate bad pixels since such

regions do not contain tooth imagery but rather other background imagery (e.g., the patient's gum).

FIG. 3 shows a blow up image of the pixels 42 (only representative pixels 42 are shown), which make up the tooth image 40 of FIG. 2. In accord with the invention, these  
5 pixels are transformed into pseudo-pixels 44 of FIG. 4. Each pseudo-pixel 44 is made up of all real pixels within the area of the associated pseudo-pixel 44. Two pseudo-pixels 44b illustrate, for example, how a pseudo-pixel can be generated from nine real pixels 42. FIG. 4 also illustrates that an image can be made from either a real tooth 40 (resulting in a REAL IMAGE) or a reference shade 40 (resulting in a REFERENCE IMAGE). REAL IMAGES  
10 and REFERENCE IMAGES are correlated to find the composite match number (CMN) as described above.

FIG. 5 shows another embodiment of an end piece 98 used in accordance with a specific embodiment, that mounts to, or is made integrally with, the end of the sleeve (e.g., the sleeve 22, FIG. 1) and which has a series of tooth shades 100 disposed in the end plate  
15 98, so that for each target 102 (e.g., the tooth or tooth shade), all relevant manufacturing shades are provided in the same digital image, thereby preventing color contamination or other anomalies caused by time delay. As discussed above, when using the end piece 98 of this embodiment each shade 100 is processed as a REFERENCE IMAGE and the tooth 102 is processed as a REAL IMAGE relative to those REFERENCE IMAGES to find a CMN.  
20 Preferably, a black border 104 surrounds the tooth aperture 106 and tooth 102. Also preferably, the remaining area 106 about the border 104 and in the end piece 98 is a reference area. By way of example, the reference area 106 is a white reflecting region with can be sampled by detectors that image that region 106. Further examples of the use of reference area are discussed below.

25

### Isolation Sleeve

In a preferred embodiment, an isolation sleeve is used to reduce variations in the images captured and processed by the system, and in particular to eliminate light contamination from external sources. In addition, the isolation sleeve preferably keeps the  
30 reference shade and the actual tooth at a set distance from the illumination source and the camera optics. The sleeve also preferably sets the angle of illumination between the source and the tooth so as to reduce reflections. More particularly, the REFERENCE IMAGES and the REAL IMAGE are preferably taken at the same illumination intensities, at approximately the same distance, and without substantial specular reflections from the  
35 source. To this end, in a preferred embodiment the sleeve shields the camera detector from imaging outside light and instead utilizes internally generated light (i.e., internal to the



camera, for example, or associated with an intra-oral wand attached to the camera) that can be controlled. The sides (or side) of the sleeve are coated in a specific embodiment with a black material (e.g., a paint or a black mat paper, or black felt), which reduces reflections along the sleeve to the tooth or reference shade. As used herein, "target area" refers to the image gathering location that the system of the invention (i.e., that region captured by the camera's detectors), including the REAL or REFERENCE IMAGE, as defined above.

FIG. 6 shows one end of wand 130 and a sleeve 132 constructed according to a specific embodiment of the invention. As in the example shown in FIG. 1 above, the wand 103 connects to a solid state camera (not shown, for purposes of illustration) to collect digital images of the target region 134 at the end of the sleeve 132. By way of example, the target region 134 includes an aperture (not shown) for imaging a tooth therein. Light 135 from the camera or wand 130 exits the wand 130 at optical aperture 136 to illuminate the target region 134.

In a specific embodiment illustrated in FIG. 6, the sleeve 132 used in the camera system of the present invention includes an accordion-like exterior, which permits soft placement of the end of the sleeve onto the patient's tooth. Preferably, such a sleeve is not entirely rigid so that the sleeve 132 can make contact without concerns about damaging the tooth. The outer portion of the sleeve 132 in this embodiment thus acts similar to a spring, and an inner structural member within the sleeve sets the final source-to-tooth distance once the outer sleeve/spring compresses to the desired location.

As shown in FIG. 6, the accordion-like sleeve 132 compresses between the target region 134 and the wand 130, as shown by compression arrow 138. In operation, a user of the wand/sleeve 130/132 pushes the sleeve 132 to the patient's tooth, and the sleeve 132 compresses to provide comfortable (i.e., non-rigid contact). In a preferred embodiment, the sleeve 132 is spring-like to provide some force opposing to compression. This force increases until there is an interaction between the sleeve 132, and/or the end piece of the sleeve 132 (i.e., the part of the sleeve at the target region 134), and the rigid structural member 140 within the sleeve 132. The member 140 stops compression at a fixed location so that a set distance is achieved from the aperture 136 and the target region 140; and so that a repeatable image size is attained.

### Illumination

As noted, in a preferred embodiment, the camera system of this invention includes a light source that illuminates the target area. In a specific embodiment the sleeve 132 can be made to rotate so that images are gathered from difficult locations in the mouth. Preferably, the light source is tied to fiber optics which rotate with the sleeve so that regardless of

sleeve position the source-to-target area remains approximately fixed. In another aspect, the camera includes optics, such as image collection optics and/or an entrance window. In system embodiment including this feature, the camera optics is tied to fiber optics, so that images are captured effectively regardless of the position of the sleeve.

5 In another aspect, the sleeve used with the dental camera system of the present invention incorporates imaging optics which relay the tooth image through a Lyot stop, to prevent passage of unwanted light energy to the camera detectors. In a specific embodiment, the sleeve incorporates baffling - such as "two-bounce" optical stray light baffling - to reduce or substantially eliminate stray light from external sources to the desired  
10 tooth image area.

FIG. 7 shows illumination arrangement wherein the source 150 of the illuminating wand 152 (connected to the solid state camera, not shown) is angled from the target area 154. As shown, the sleeve 156 connected to the wand 152 is arranged adjacent to a patient's tooth 158, so that digital images can be taken of the tooth 158 (according to the  
15 practices discussed herein) through the wand's optical entrance aperture 160.

For purposes of illustration, FIG. 7 also shows how light 162 emitting from the source 150 travels in a generally specular direction 164, reflecting off the tooth 158 into a direction 166 that is away from the aperture 160. Those skilled in the art will appreciate that scattering does occur off the tooth 158 and into the aperture 160, but that the  
20 arrangement eliminates some unwanted reflections into the aperture. Light captured through the aperture 160 is relayed by optics (e.g., fibers and/or relay lenses) to the camera's focal plane (not shown) to generate digital images of the tooth 158.

FIG. 8 shows another embodiment of a sleeve 168 constructed according to the invention to reduce passage of light 171 into the wand's entrance aperture 169 from sources  
25 170 away from the target object (e.g., the tooth 172). The sleeve 168 is especially useful in imaging the tooth 172 without adjacent proximity to the sleeve 168, as illustrated in FIG. 8. The sleeve 168 includes baffles 168a known in the art, which require at least one "bounce" and preferably two bounces of the light 171 prior to gaining access to the entrance aperture 169, thereby significantly attenuating "out of field" sources 170 (i.e., those unwanted  
30 sources which might influence the color measure, e.g., room lighting). For simplicity, in this illustration the wand and solid state camera are not shown. Baffles 168a can be placed within other sleeves shown herein to improve out-of-field stray light rejection.

As noted above, in order to ensure high-quality images which do not depend on the specific lightning conditions at the time the pictures are taken, in accordance with this  
35 invention it is important to minimize the influence of such factors. Accordingly, in another specific embodiment, the sleeve used in the dental camera system of this invention includes

a reference sample disposed at the end of the sleeve, near the target area, so that: (a) color comparison information can be obtained; and/or (b) the camera has sufficient reflective surfaces from which to effectively trigger the camera's auto-brightness and/or auto-color features. Specifically, as to feature (b), certain cameras available on the market include electronics and software which automatically adjust brightness and/or color in a digital image. Preferably, in this embodiment such features are disabled. In the event they are operating, however, the reference sample is sized so that a sufficient reflection area is generated at the end of the sleeve, whereby the camera can operate to capture good color images. By way of example, as to feature (b) above, the sample should be sized so that RGB values vary in a controlled or calibrated manner throughout the reasonable tooth shade reflections (e.g., throughout all VITA Shades).

As to feature (a) above, one preferred embodiment utilizes the reference sample to obtain a color reference used to reduce variations in the digital image. "Color" is based on "reflection" - that is, what the camera sees at the target area is based on reflection of whatever source illuminates the target. With the sleeve used in a preferred embodiment, the source is limited to the camera's illuminating source, thereby eliminating other sources and color variations that are not controllable (e.g., the ambient lighting in a building). It is well known that a black body absorbs visible light; and a white reflects the light. In one embodiment, therefore, the reference sample is as white as possible so that it exhibits very little color (and particularly, the sample reflects light equally in the visible light range from between about 400nm to 800nm). When using a white reference sample in accordance with this embodiment of the invention, the following process occurs:

- 1) Compute average RGB values (and/or other image variables such as hue) for several or all pixels imaged of the reference sample. This computed average is referred to as REF RGB.
- 2) For each digital image (i.e., for both REFERENCE IMAGES and REAL IMAGES), subtract REF RGB from RGB pixel values for that image. Keep track of the sign (i.e., positive or negative) of the result. The result is referred to as "REF RELATIVE RGB" (i.e., image RGB - REF RGB).
- 3) Utilize a correlation algorithm, such as described above, (i.e., for the CMN) on REF RELATIVE RGBs as opposed to absolute RGB values (for the pseudo-pixels). Note that when the RSS (i.e., subtract and square) of the CMN algorithm is computed, the sign of the REF RELATIVE RGB matters. For example, if the REFERENCE IMAGE RGB is -.1,-.5,-.6, and the REAL IMAGE RGB is .1, .7, .9, then this REAL IMAGE has quite a bit more color difference (compared to the REF

IMAGE, which is the important quantity) than, e.g., a REAL IMAGE with -.05, .2, .1. Afterwards, the square of the RSS destroys the sign importance.

The reference sample compensation algorithm described above is used in a specific embodiment to compensate for certain variations. Thus, the auto-brightness feature of certain cameras changes the color of the light emitted from the camera (this is sometimes referred to in the art as the color temperature). Unfortunately, the emitted RGB is not known except for the reference sample, which reflects the source light back to the camera detectors. A good reference sample will thus reflect nearly all colors equally. Since one is interested in differences between REAL IMAGES and REFERENCE IMAGES, the real concern involves differences and not absolute colors.

The reference sample compensation thus also compensates for image acquisition changes which occur over time. For example, the source may emit more or less light, over time, even over several minutes or hours; and it would be desirable to eliminate such variations to increase the sensitivity to color comparisons. The passage of time during an image acquisition sequence only adds to the variability in the measurement: the source color temperature may change, the detector sensitivity or gain may change, etc. With the above reference sample adjustment, if for example one has a perfect white tooth, then its REF RELATIVE RGB is 0,0,0. Assuming that a tooth shade exists that was also perfectly white, it would have a REF RELATIVE RGB of 0,0,0 - creating a match.

In another embodiment, the white reference is integrated to find REF RGB, per frame. REF RGB is then subtracted from each pixel RGB in the image (or the other way, i.e., image RGB subtracted from REF RGB, as long as consistent throughout every measurement). In another embodiment, REF RGB is subtracted from pseudo-pixels; but preferably REF RGB is subtracted from real pixel RGBs.

In another embodiment, the sleeve used with the dental camera system of the present invention is formed in the following way. At the end of the sleeve, a central aperture exists preferably in the middle of the target area (e.g., an object such as a tooth or shade is placed at the aperture). Surrounding the central aperture is a black border, to provide high contrast at the edges of the target object. A target object such as a tooth is thus readily defined and discerned within the black border. The aperture also fixes the size of the image for the tooth or tooth shade. Some or all of the remaining area at the end of the sleeve (captured by the camera detectors) in the target area is a white reference sample.

The amount of white reference sample in the target area can be chosen experimentally. By way of example, the average mid point in the auto-brightness (if operating) is obtained so that on average REF RGB changes little. The size of the white sample in the target area is adjusted in area until REF RGB is minimized for all shade

values, e.g., A1-A4, B1-B4 and so on. With more black in the image due to less reference sample area, the auto brightness control on the camera (if applicable) adjusts to higher gain to 'balance' the intensity of the image, causing the reference and sample parts to saturate in the red and green.

5 As noted above, in a specific embodiment, the walls of the sleeve are selected mat black to eliminate reflections, but the facing plate containing the target area is bright to force the camera gain downwards, out of non-linear color operability. In this embodiment preferably the camera's auto features are turned off (and at least any white balance is set to manual). In one specific embodiment, the reference sample is made of a light colored felt  
10 material. In alternative embodiments, the sleeve walls are made of a felt material. In these embodiments, the felt material has elements which extend away from the material producing more of a lambertian surface. Such surfaces are preferred as they reduce unwanted specular reflections. Also, the sample reference produces an excellent image when it is not specular. Alternatively, a black velour paper can be used in the sleeve, such  
15 as by JL Hammett Co.

FIG. 10 illustrates a non-contact re-imaging system 250 used in accordance with another embodiment of the present invention to image a target tooth 252 without contact between the tooth 252 and a sleeve 254. Optics 255 reimage the tooth 252 internal to the sleeve 254, at internal image 256, and a Lyot stop 258 is used to reduce unwanted stray  
20 light entering the aperture 260 to the camera (not shown).

FIG. 11 illustrates a non-contact re-imaging system 300 used to image a target tooth 302 to a digital camera 304, and without contact between the tooth 302 and the system 300 or camera 304. Although this reimaging system 300 can be made in several forms, in one embodiment the system 300 includes a sleeve 306 that permits hand-held manipulation into  
25 a patient's mouth to capture the digital image of the tooth 302. By way of example, optics 308 reimage the tooth 302 internal to the sleeve 306, at internal image 310, and a stop 312 is used for color referencing in analyzing the tooth color. Stop 312 forms an aperture defined by edge 312a. FIG. 12 illustrates one digital image 320, as taken by camera 304, of the tooth 302 and the inside view of stop 312. The region 322 defines that region inside the  
30 patient's mouth that is not the patient's tooth 310. Region 324 consists of a color reference which is used as described herein to relate and compare to color pixels of the digital image of the tooth image 310, so as to better define tooth color.

Those skilled in the art will appreciate that a reimaging system such as in FIG. 11 can be made in several ways. By way of example, system 350 of FIG. 13 shows one system  
35 of the invention to reimage a tooth 352 to an internal image 354 for reimaging into a digital camera 356. As above, camera 356 takes SNAPSHOTS of the tooth 352, for color analysis.

Optical element 358 images the tooth into optical fiber bundle 360, which relays the image from one side 360a to the other side 360b of the bundle 360, as known in the art. Optical elements 362 provide for reimaging to form the internal image 354 at the stop 364. As above, the stop 364 has a reference color disposed thereon, facing camera 356, so that a reference color image is attained such as in FIG. 12. Fiber optic bundle 366 relays the image 354 from side 366a to 366b, and exit optics 368 provides for relaying the tooth image to the camera 356. One convenient feature of system 350 is that fibers 366, 360 can be flexible; and a sleeve 370 can support these elements to provide a hand-held wand that can be inserted into a patient's mouth to acquire the image. Camera 356 can provide its own light source 356a which generates light 356b back along the optical path taken by tooth image 354. The advantage of this is that source 356a can be carefully selected for its color characteristics to facilitate tooth color detection; and further light 356b can illuminate stop 364 inside the sleeve or wand 370 so that the camera 356 can detect and compare its color to the tooth's color image 354.

#### 15 **Tooth Restorative Processing**

FIG. 14 shows certain tooth restorations and decays, which illustrations can help understand more fully aspects of the invention discussed above. A healthy tooth, free from any decay with no current restoration ("restoration" is any part of a tooth that is replaced with a material that allows the tooth to remain in the mouth as a functioning and whole structure) is referred to as a "virgin" tooth. Despite advances in preventative treatment and services (fluoridated water, fluoride treatments, sealants - which are unfilled resins that are bonded into deep grooves of posterior or back teeth to prevent decay in those areas), 50% of American children by age 12 have occlusal decay (decay in the top, or biting surface) in permanent molars which erupted or came into their mouths at age 6.

25 Typical progression of decay in a tooth is as follows: Following C.V. Black's classifications, a tooth can require a restoration in the following positions:

CLASS 1 - occlusal area, that is, within only the top or biting surface of the tooth, usually beginning in the groove or crevice. This term is used only for posterior (back) teeth, i.e., molars and premolars.

30 CLASS 2 - area made up of occlusal and one or more sides of the tooth, either mesial (wall towards front) and/or distal (wall towards back) and or buccal (wall towards cheek) and or lingual (wall towards tongue) so that a class 2 restoration may be termed "MO" (mesial-occlusal), "MOD", "OB", etc.

CLASS 3 - area of an anterior, or front, tooth involving only an interproximal wall, that is mesial or distal, areas that face neighboring teeth.

CLASS 4 - area of an anterior tooth involving the incisal (bottom) edge and an interproximal wall.

CLASS 5 - area of any tooth on only the buccal or lingual wall

CLASS 6 - area of a tooth involving the cusp tip ( cusp being the highest point of the tooth , like the mountain peak; this would apply to canines, premolars, and molars)

Once decay is detected, through clinical examination, radiographs, etc., the decayed portion of the tooth needs to be removed. This is achieved through the use of a handpiece (drill). Once excavation of decay is complete, the remaining tooth structure is evaluated for restoration possibilities. A "filling" is placed if 50% or more of the tooth remains, with the stress-bearing areas of the tooth remaining intact (such as cusps and walls of the tooth which are active in biting and chewing process). If these areas of the tooth are compromised, a laboratory-processed restoration is required.

Consider a specific example, in which it is assumed that the tooth needs a restoration, which will be placed right in the office, say a MO on a molar. The choice of materials is made, which could be either amalgam (silver, not done much anymore), or composite or ceromer, which are tooth-colored direct materials (Matrix of ground plastic and /or glass in a bis- GMA resin). A shade needs to be selected for the material, such as described herein in accord with the invention. The tooth is cleaned and isolated from saliva and blood by use of cotton rolls, matrix bands, possibly a rubber dam. The tooth surface is etched with a cleanser (typically 37% hydrophosphoric acid), rinsed, and treated with an adhesive, which is bonded to the tooth by use of a curing light - a light with a wand attachment that is about 11 - 13 cm in width and emits a light in the range of 400-500 nanometers. The material is then placed into the cavity by hand instruments or via dispensing through a carpule/cartridge system in a syringe. The material is somewhat condensed into place at 2-3 mm intervals, and light cured in between. Upon final filling, the restoration is polished and contoured using finishing burs (tips) on the handpiece (drill).

If the tooth requires a lab fabricated restoration, such as an inlay, onlay or crown, further steps need to be taken (Inlay being a Class 2 restoration NOT including cusps, onlay being a Class 2 restoration including cusps, crown being full, or total coverage of the tooth). The tooth is shaped to make the final shape not have any undercuts, with walls as parallel as possible for retention purposes.

Then an impression, or mold is taken of the tooth, which is in a material that remains accurate despite temperature changes, moisture, pouring stone into the mold and removing it several times. An impression of the opposite arch of teeth, or opposing arch, is taken also so that the technician can articulate, or put together the two arches and simulate the patient's mouth or bite. A registration of such a bite can be taken also and sent with the

case. So that the things sent to the lab for such a case are: impression of the tooth to be restored and adjacent teeth, model or impression of opposing teeth, and possibly a bite registration.

Those skilled in the art should appreciate that the invention to determine the appropriate color shades of the tooth as illustrated in FIG. 14 can be accomplished by the methods herein, and/or by systems disclosed in the several figures. Using a wand of the invention, furthermore, various teeth (as in FIG. 14) can be acquired for digital evaluation. In accord with the invention, digital files of patients' teeth can be stored in memory of computer 14, FIG. 1, for a permanent record. A patient can then be evaluated over time for color changes.

#### MISCELLANEOUS ASPECTS

Although the VITA™ Shade guide is often discussed herein, it should be apparent that other shade guides and porcelains can be stored as REFERENCE IMAGES and compared to REAL IMAGES in alternative embodiments of this invention. Computer memory can store a large number of images, even from different manufacturers, so as to provide the optimum color fit to a patient's tooth. By way of example, IVOCCLAR has one suitable shade guide, as well as various materials of porcelains, ceromers, polymers, and others. In accord with the invention, a database can store REFERENCE IMAGES for match correlation to REAL IMAGES. Alternatively, in one aspect, the invention performs a conversion to other manufacturer shades and or porcelains so that alternative laboratories can be used without undue concern for manufacturer alliance. Specifically, in accord with one aspect of the invention, a conversion between known shade guides is provided for increased lab selectivity. It will be appreciated that the conversion of digital images involves mapping from one set of color coordinates to another, which procedure is well known in the art and need not be considered in further detail.

As described, one major problem due to auto brightness is that if there is not enough light material in the image, the auto brightness turns the gain up too high, and the R and G values saturate in the sample. By adding sufficient light colored reference area, the balance of light to dark is better, but the reference can saturate in places. This can be compensated some by using an end plate at the end of the sleeve that will be all white but with the black border round the sample aperture. A reference color area can be included in one corner so that the camera adjusts brightness for the constant white area leaving the reference and sample somewhere in the middle of the operable RGB ranges.

In still another aspect, instead of subtracting the RGB from the reference sample, an average of the reference sample is used. Specifically, over the range of images taken, an



average REF RGB (denoted "AVE REF RGB") is determined for the reference sample. For each individual image, the difference is calculated between the REF RGB and the AVE REF RGB. This delta RGB is then added to the image RGB to correct for any compensation in the camera. Thus if the image is brighter than the average image, the difference is subtracted from the sample values and vice versa.

In still another aspect, the reference sleeve has an end plate which contains all tooth shades for a given manufacturer (so that one sleeve is used for a particular manufacturer). Any image therefore acquires the sample tooth as well as all the tooth shades; and image processing commences on the one digital image. This is advantageous in that camera color drift is compensated for since all images are taken at the same time.

When determining tooth color, if the shade does not correspond to an existing shade (such as A1, D4), a system 400 is provided as shown in Fig. 15 which will create a recipe for whatever shade the tooth is. Color digital information about the tooth under test is sent to system 400 over a communication line such as the Internet; and system 400 selects porcelain mixtures from supply 402 to be sent and mixed within mixing subsystem 404. Subsystem 404 dispenses the mixture into a capsule 406 for the dentist, which administers the final mixture to the patient's tooth.

The new shade material in capsule 406 is either provided chair-side, or reported to the technician over the Internet 410 (in which case, system 400 can be present at the technician's site). If for example the dentist needs to use a composite material like HELIOMOLAR by Ivoclar, and the desired shade is something between C2 and C3, the system determines the new shade of "C2/C3", mixes component composite materials accordingly, and dispenses to the dentist a premixed capsule/cartridge 406 of material to be used on that patient. Information to be sent to the lab can include a recipe that will instruct the technician as to how to create the new shade using whatever material is selected - porcelain, ceromer, pressed porcelain, etc.

Fig. 16 illustrates in a block-diagram form the configuration of the interactive network system in a preferred embodiment. As shown, this system is implemented as a (preferably website) server 1610, having access to one or more databases 1630 containing information about different aspects of dental restoration. As noted, this information in a preferred embodiment includes materials, procedures and preparation recipes related to various dental restoration prostheses, and may include preparation design, recommended burs to achieve such a preparation, recommended temporization materials, cements that should be used with that given material, instructions on how to use such a cement and where to buy such materials, and others. In addition, database 1630 may contain information about different dental procedures, and in particular answers to commonly asked

questions. In yet another embodiment, the database may also contain patient histories, so that a dentist (or a technician) having access to the system can read the patient history regardless of where they are located physically, provided that they have proper authorization to access this information. The database may further be connected to external information source(s) providing input from product manufacturers, market research or others. In accordance with the present invention there is no restriction on the type of database design that can be used.

In operation, users can access the service over a communications network 1620, such as the Internet, using data entry devices, designated 1640 in Fig. 16. Generally, devices 1640 can be implemented as any color-display device capable of communicating over the network 1620. In the preferred embodiment where the network is the Internet, for example, such capability is provided by browsers, as known in the art. Thus, a device 1640 can be a conventional personal computer 14, as illustrated in Fig. 1. In alternative embodiments that do not communicate over the Internet such a device should have a capability to communicate over a communications network, e.g., an intranet, as known in the art.

In a preferred embodiment, the server 1610 is a computer, the type of which may range from a personal computer to a workstation or a larger computer or a network of computers. The choice of a specific computer system is based on known trade-offs, and thus will not be discussed in further detail. In the preferred embodiment, the server is Internet-enabled but it will be appreciated that in alternative embodiments it can support another network, e.g., an intranet. Broadly, the server 1610 comprises a processor 1650 and random access memory (RAM) and read-only memory (ROM), collectively designated 1670. The processor 1650 is adapted to execute instructions in different computer languages and can operate in different operating system environments, such as the PC/Windows™ environment. In a preferred embodiment, the server also has a data formatting device 1660 serving to provide interface with the database(s) 1630. In various embodiments the server can be provided with additional devices (not shown) such as a point-and-click device (like a mouse), keyboard, a monitor and various other devices, which may include, for example a printer 46. Preferably, the server is equipped with means for connecting to external communications media, and may include various connectivity types, such as a LAN connection.

It will be appreciated that using the system shown in Fig. 16, different users 1640 can access information stored at the network server (or to which the server has access). It will also be appreciated that the system would enable direct communication between users, such as on-line communication between a dentist and a dental restoration laboratory, where

the two sides can simultaneously have access to a patient record, an image of tooth in need for restoration or others. Naturally, if desired, such communications can be established over dedicated lines although in accordance with this invention it is desirable to use open systems, such as the Internet because of the flexibility they provide. Further, while they are  
5 shown separate for illustration purposes, it should be apparent that the server 1610 can physically be located at dentist's (or laboratory) office. Communications networks and servers of the type illustrated in Fig. 16 are generally known in the art and thus need not be described with specificity.

While the invention has been described with reference to the preferred  
10 embodiments, it will be appreciated by those of ordinary skill in the art that various modifications can be made to the structure, form and operation of the various embodiments of the invention without departing from its spirit and scope, which is defined in the following claims.

15 **APPENDIX A** contains, for disclosure purposes, non-limiting source code for use with certain aspects of this invention.

20

25

30

35

## THE CLAIMS

What is claimed is:

- 5           1.     An interactive dental restoration method between a dentist and a dental  
restoration laboratory which comprises:  
              identifying a dental restoration need in a patient;  
              designing a preliminary treatment plan that includes design criteria for  
preparation of a dental prosthesis to be placed in the patient to satisfy the dental restoration  
10 need;  
              transmitting the preliminary treatment plan via a communications network to  
a dental restoration laboratory; and  
              communicating a final treatment plan, including modifications to the  
preliminary treatment plan if necessary, to the dentist.
- 15           2.     The method of claim 1 wherein the dentist prepares the preliminary  
treatment plan and the design criteria include digital image representations of the dental  
restoration need.
- 20           3.     The method of claim 2 which further comprises evaluating the preliminary  
treatment plan at the laboratory before communicating the final treatment plan to the  
dentist.
4.     The method of claim 3 which further comprises implementing the final  
25 treatment plan in the patient and transmitting interim preparation information to the  
laboratory for survey with confirmation prior to completing the final treatment plan.
5.     The method of claim 3 when the step of transmitting and evaluating the plan  
are codirected over the communications network.
- 30           6.     The method of claim 5 which further comprises preparing a dental prosthesis  
that satisfies the design criteria of the final treatment plan and placing the prosthesis in a  
patient.

35

7. The method of claim 6 which further comprises verifying that the dental prosthesis is prepared according to the final treatment plan prior to placement of the dental prosthesis in the patient.

5 8. The method of claim 6 wherein one of the design criteria or the modifications include proposed decay excavation, tooth preparation, or prosthesis color.

9. The method of claim 6 wherein the digital image representations include REAL IMAGE and REFERENCE IMAGES and the modifications include correlation of a  
10 color selection for the prosthesis to match the REAL IMAGE.

10. The method of claim 4 wherein the design criteria include tooth preparation and proposed decay excavation, and which further comprises communication, a confirmation or modification, from the laboratory, of the acceptability of one or more of the  
15 proposed design criteria.

11. A computer-based dental restoration system comprising:  
a network server having a database storing information about materials,  
procedures and preparations concerning dental restoration prostheses;  
20 a communications network providing access to said network server; and  
one or more computers for accessing information stored at the database over  
the communications network and displaying the information in a humanly readable format.

12. The dental restoration system of claim 11 wherein the computer(s) can be  
25 located at a dental office and the communications network is the Internet.

13. The dental restoration system of claim 11 wherein information stored in the database comprises preparation diagrams, reduction dimensions, margin design and burs for specific dental restoration prostheses.  
30

14. The dental restoration system of claim 11 wherein the database further stores information concerning one or more patients having dental restoration needs.

15. The dental restoration system of claim 11 wherein the network server further  
35 comprises application programs for enabling users to query the database regarding specific

materials or procedures concerning dental restoration prostheses for confirmation, verification, modification or evaluation of the same.

16. The dental restoration system of claim 15 wherein the one or more  
5 computers at the dental office receive answers from the database to said queries and further comprising at least one printer located at the dental office to print said answers for reference in carrying out the treatment plan.

17. The dental restoration system of claim 11 further comprising at least one  
10 computer at a dental restoration laboratory, said at least one computer having access to the network server and said or more computers at the dental office over the communications network.

18. The dental restoration system of claim 11 further comprising a digital camera  
15 for taking digital images of patient's teeth in need of dental restoration and a communication link for transmitting the digital images to the one or more computers at the dental office.

19. The dental restoration system of claim 18 wherein the one or more  
20 computers at the dental office stores the digital images of patient's teeth in need of dental restoration and the communications network forwards the digital images to the database for storage therein.

25

30

35

FIG. 1

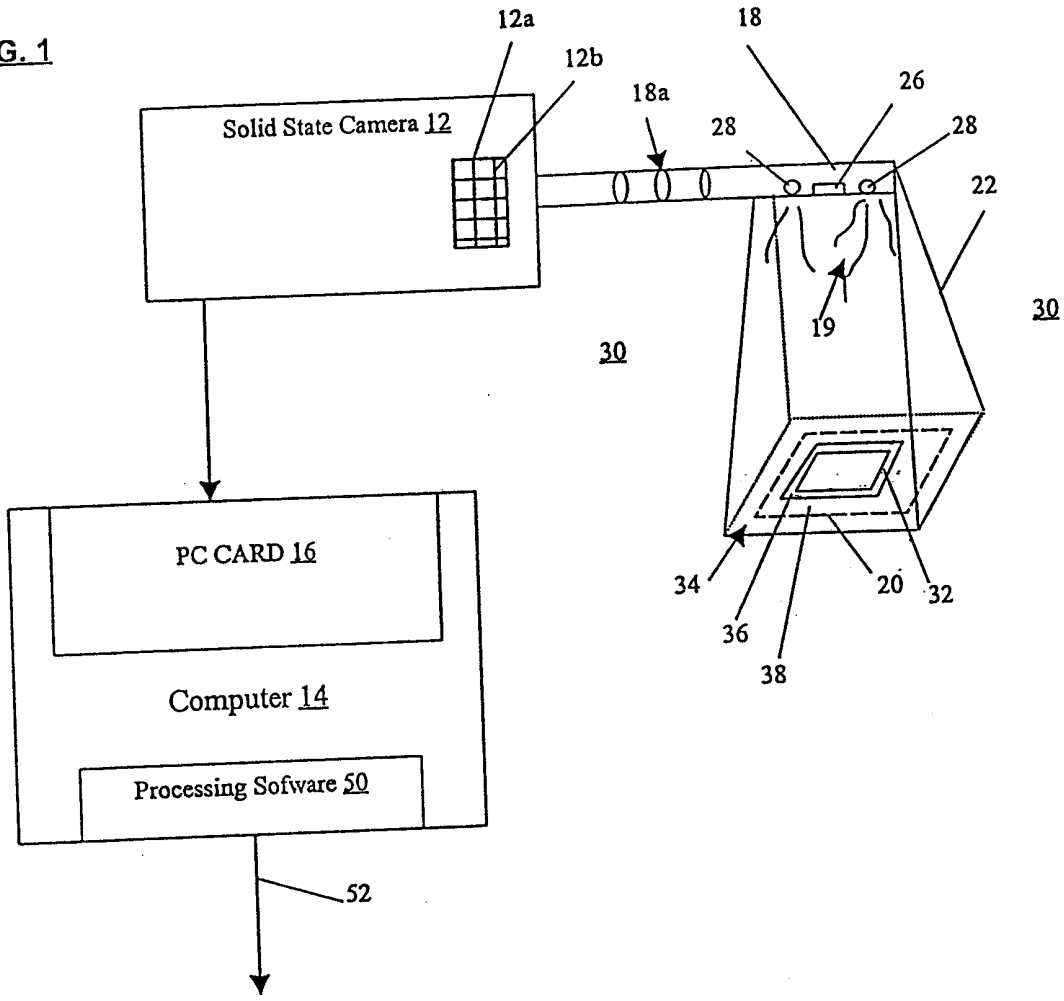
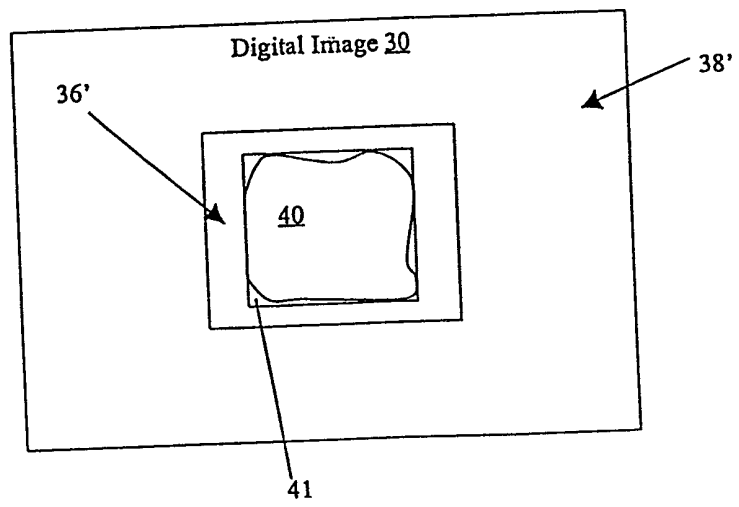
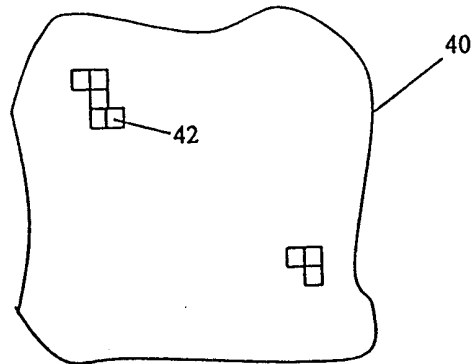


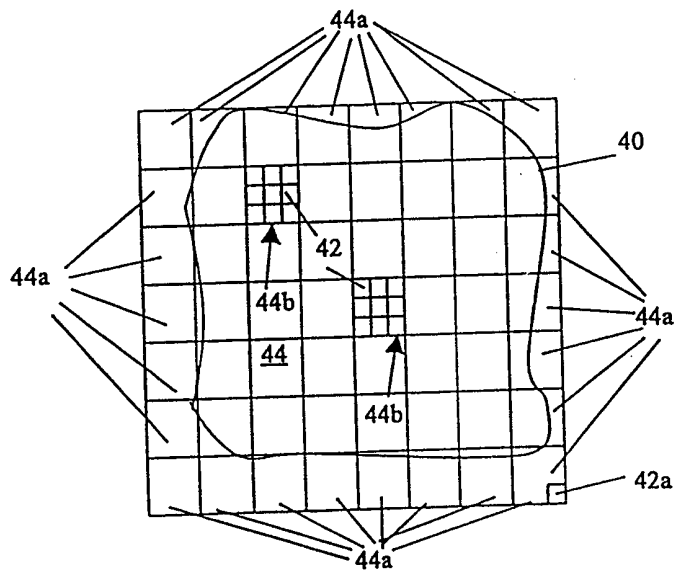
FIG. 2



**FIG. 3**

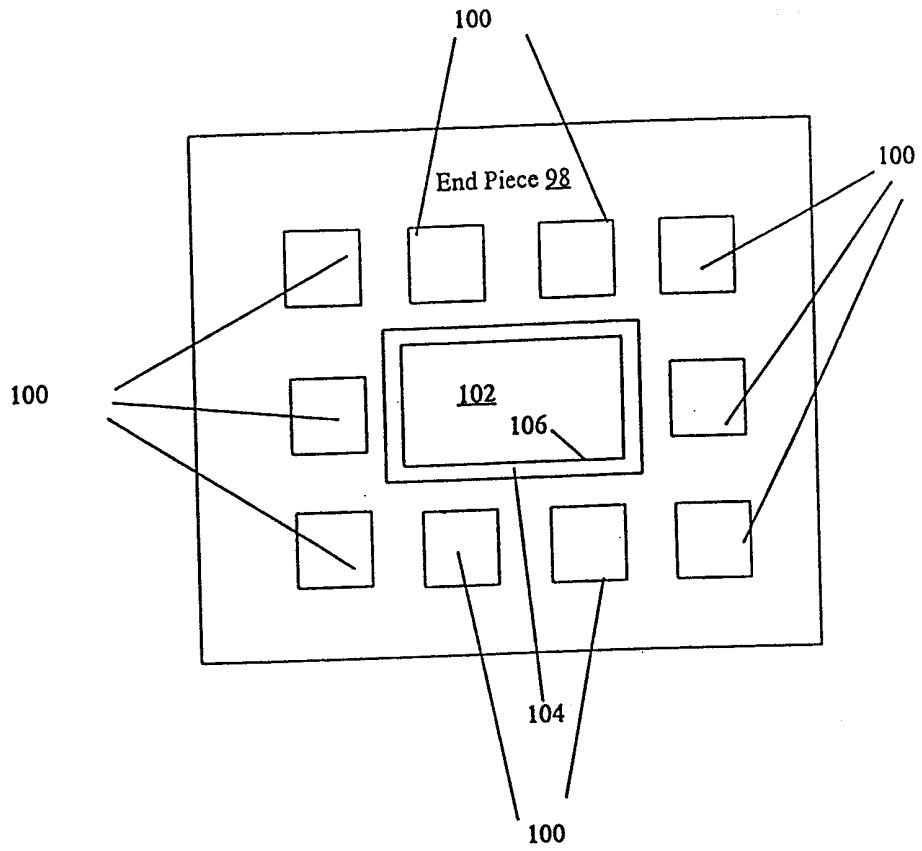


**FIG. 4**

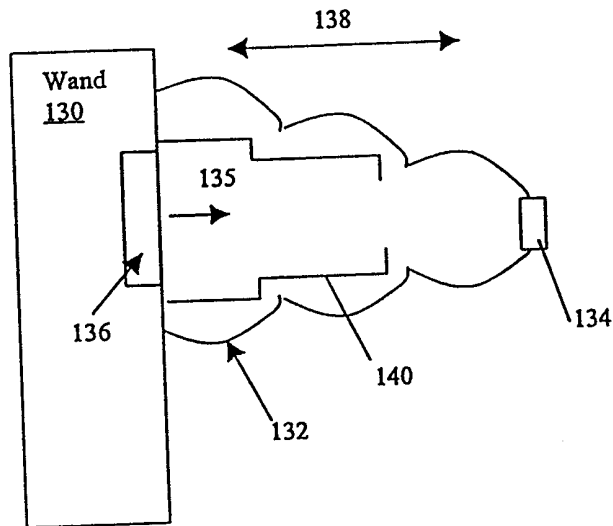




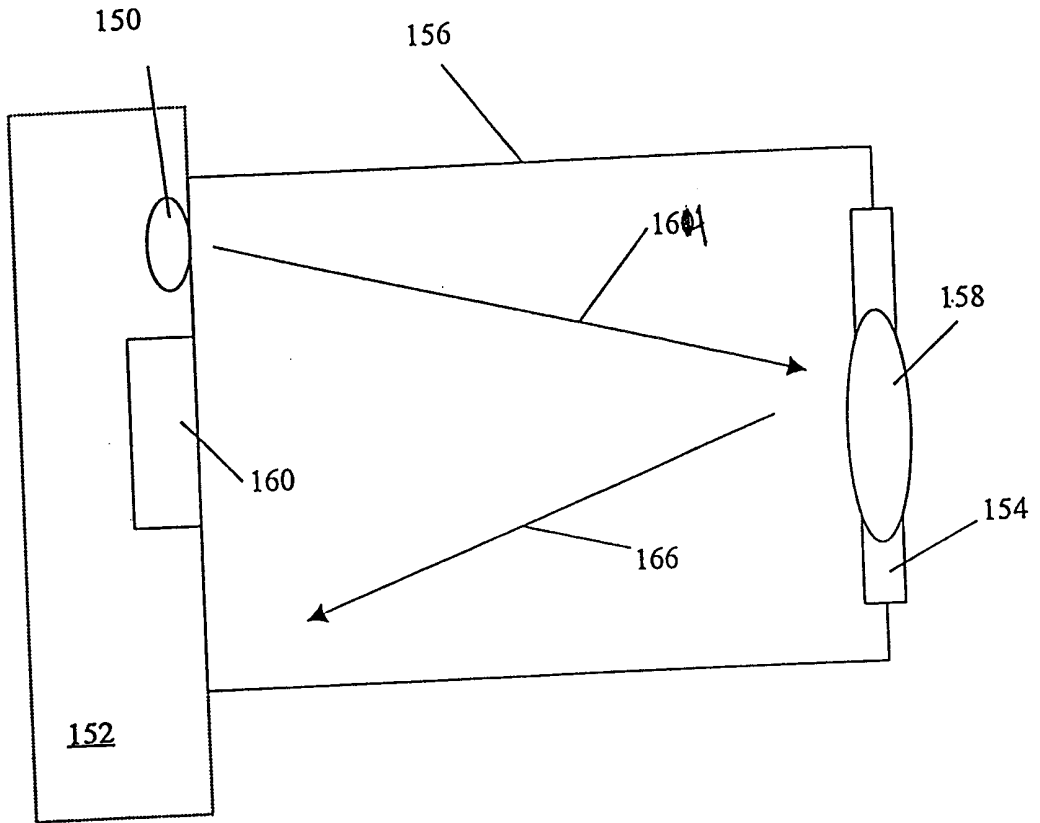
**FIG. 5**



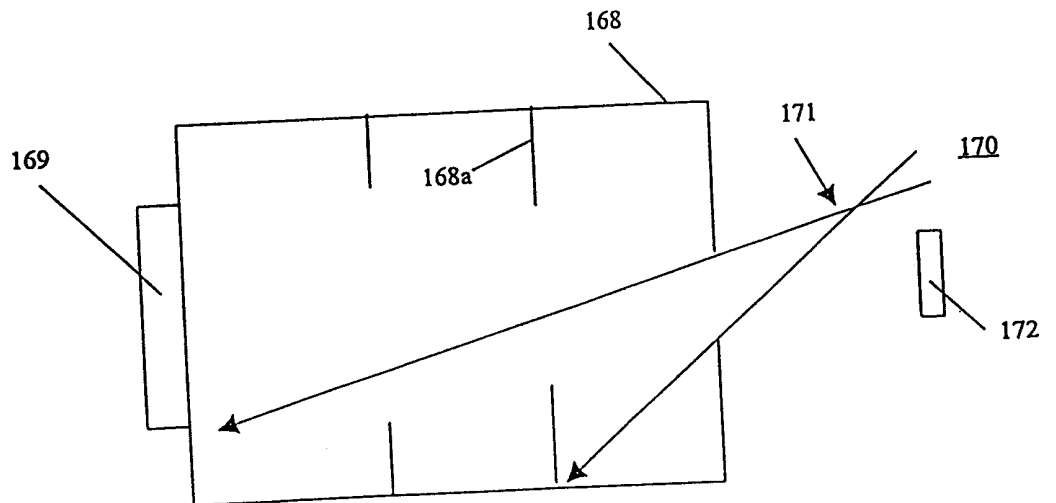
**FIG. 6**



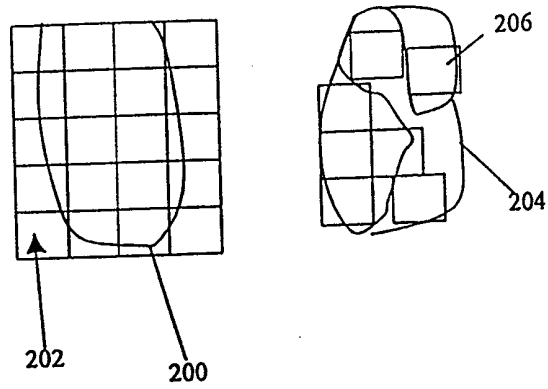
**FIG. 7**



**FIG. 8**



**FIG. 9**



**FIG. 10**

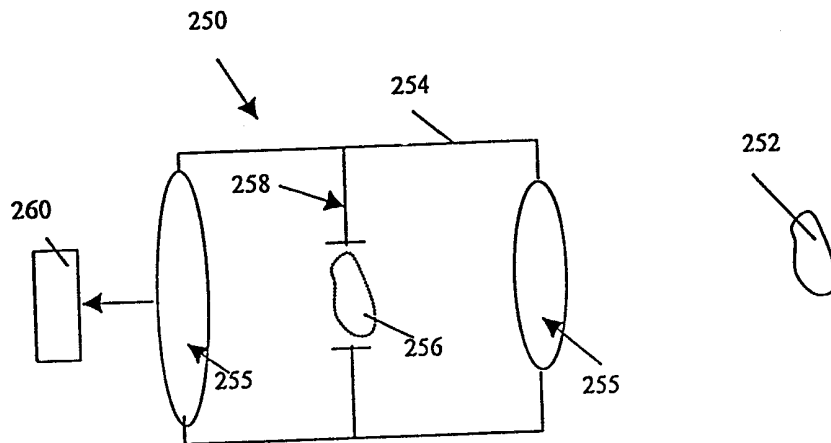


FIG. 11

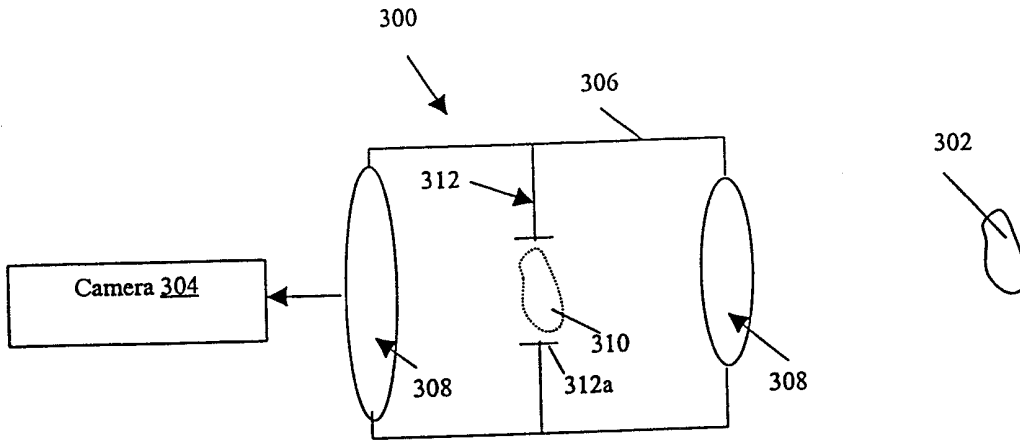


FIG. 12

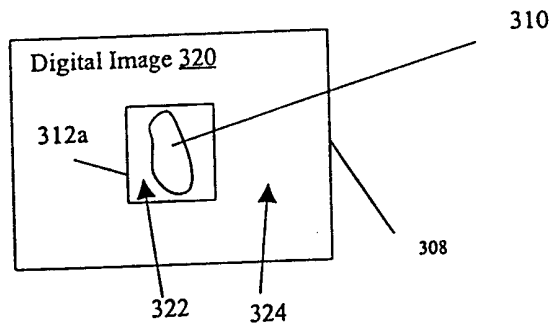
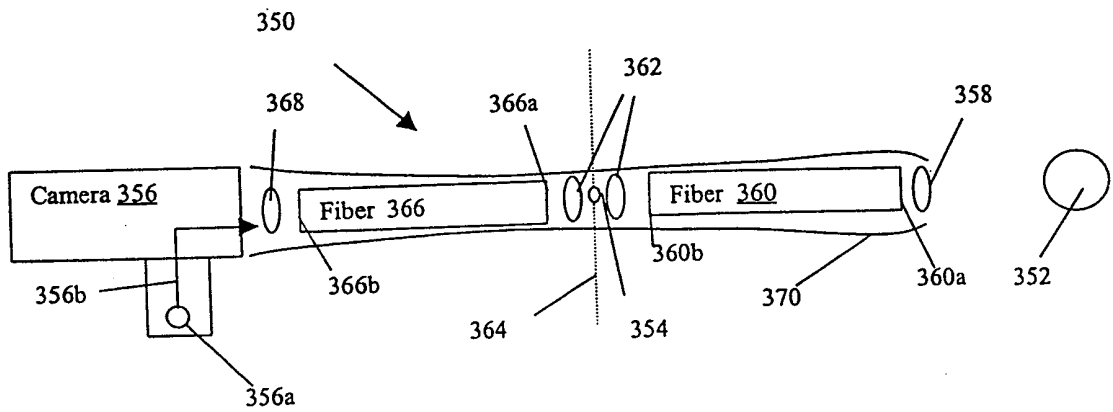
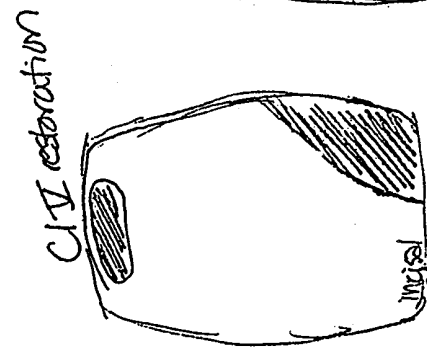
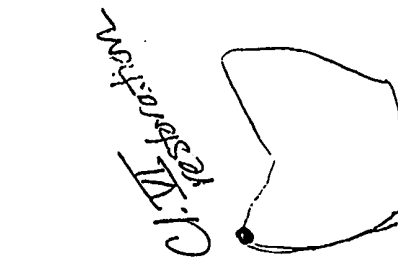
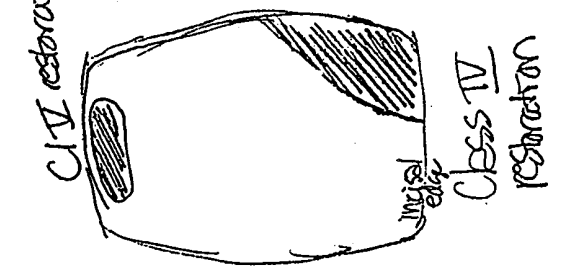
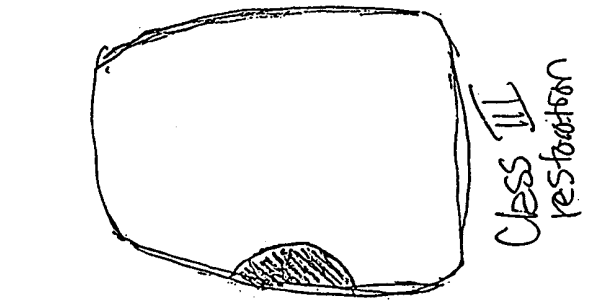
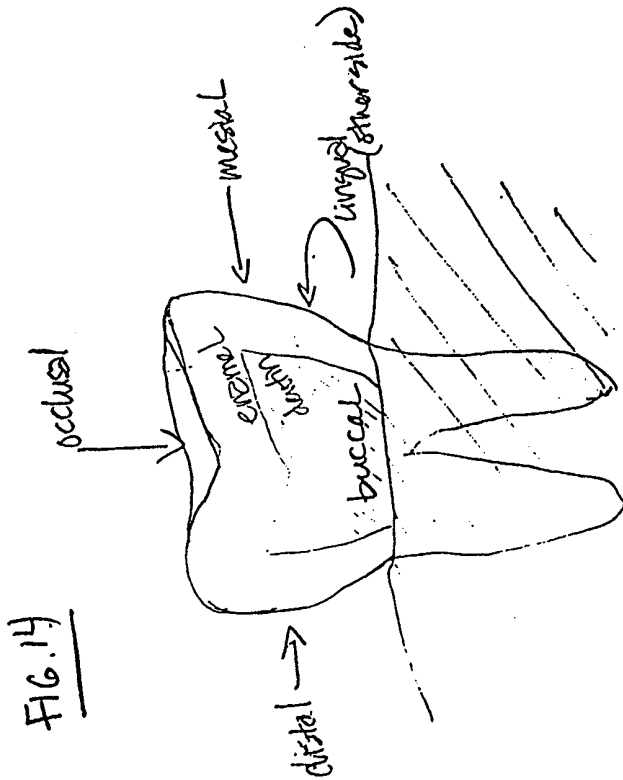
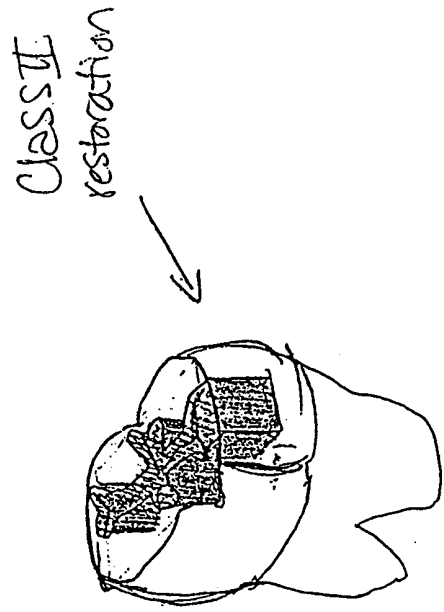
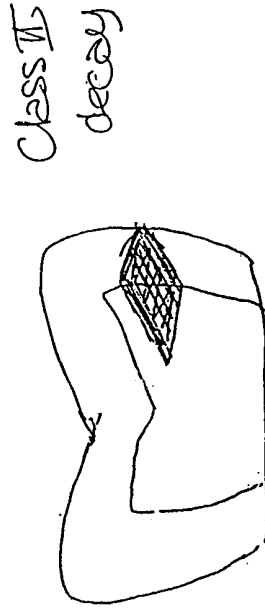
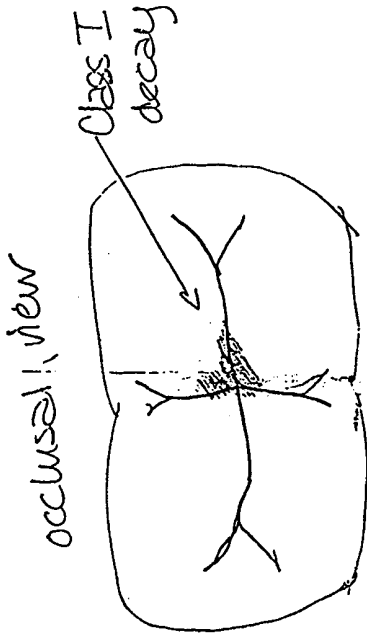


FIG. 13





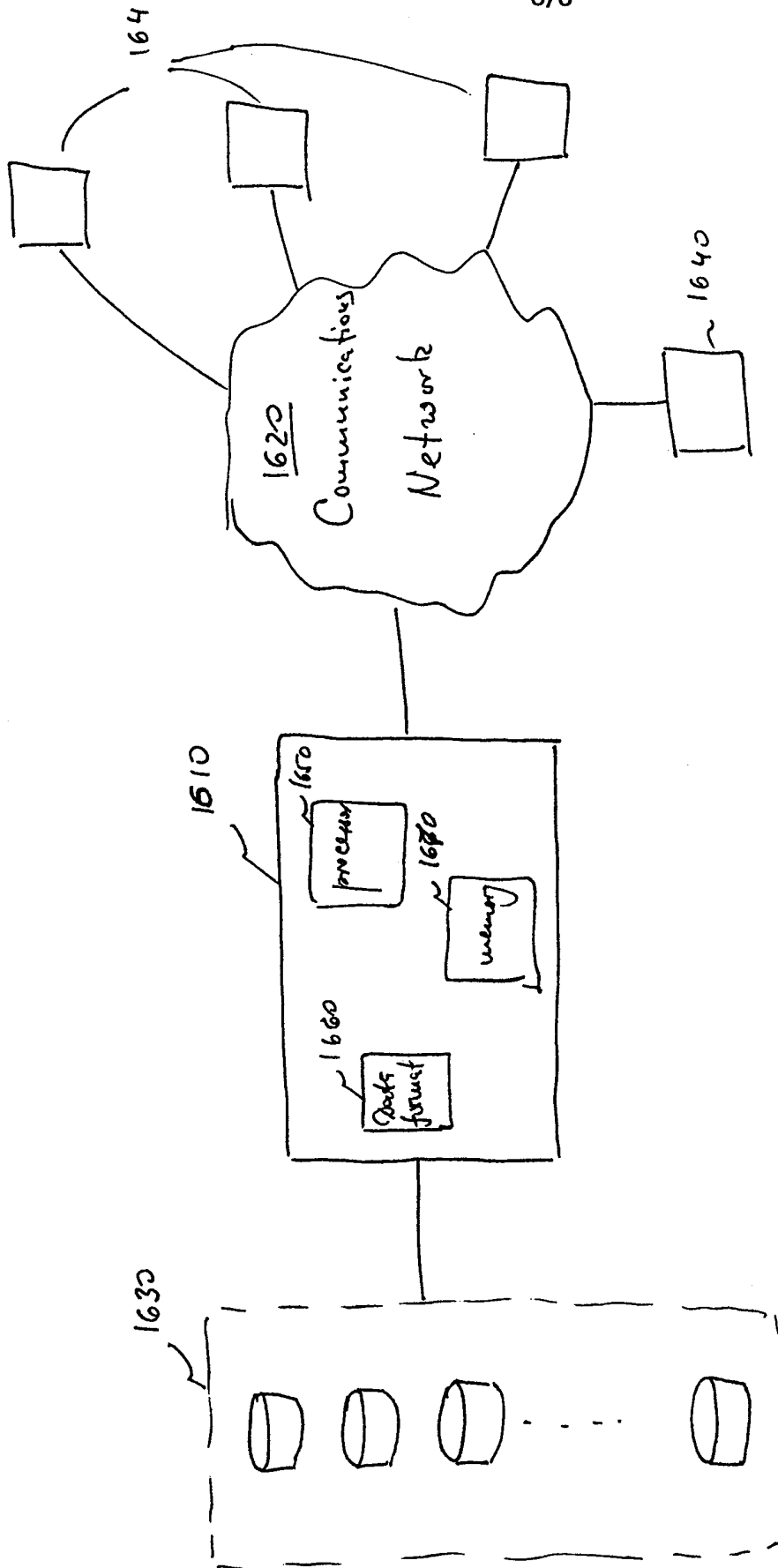


Fig. 16

**Appendix A****Software Modules**

<b><u>Module Title</u></b>	<b><u>Number of Pages</u></b>
About	1 page
ImageDisplay	3 pages
RefDisplay	4 pages
SampleLocator	4 pages
Sdimain	8 pages
ShadeData	8 pages
SplashScreen	3 pages
ToothObject	6 pages

```
unit About;

interface

uses Windows, Classes, Graphics, Forms, Controls, StdCtrls,
    Buttons, ExtCtrls;

type
    TAboutBox = class(TForm)
        Panell: TPanel;
        OKButton: TButton;
        ProgramIcon: TImage;
        ProductName: TLabel;
        Version: TLabel;
        Copyright: TLabel;
        Comments: TLabel;
    private
        { Private declarations }
    public
        { Public declarations }
    end;

var
    AboutBox: TAboutBox;

implementation

{$R *.DFM}

end.
```



```

with pmiImage.Canvas do
begin
  moveto(Left, Top);
  lineto(Left, Bottom);
  lineto(Right, Bottom);
  lineto(Right, Top);
  lineto(Left, Top);

  if Rows > 1 then
  begin
    Spacing := (Bottom - Top) / Rows;
    for index := 1 to Rows - 1 do
    begin
      moveto(Left+1, Top + trunc(Spacing * index));
      lineto(Right-1, Top + trunc(Spacing * index));
    end;
  end;

  if Columns > 1 then
  begin
    Spacing := (Right - left) / Columns;
    for index := 1 to Columns - 1 do
    begin
      moveto(Left + trunc(Spacing * index), Top+1);
      lineto(Left + trunc(Spacing * index), Bottom-1);
    end;
  end;
end; // DrawGrid

procedure TfrmImageDisplay.DrawGrids;
begin
  SetROP2(pmiImage.Canvas.Handle, R2_NOT);

  if DisplayGrid then
  begin
    DrawGrid(RefA, RefR, RefC);
    DrawGrid(SampleA, SampleR, SampleC);
  end;
end; // DrawGrids

procedure TfrmImageDisplay.FormCreate(Sender: TObject);
begin
  DisplayGrid := false;
end;

procedure TfrmImageDisplay.DefineGrids(RefArea: TRect;
                                       RefRows : integer;
                                       RefCols : integer;
                                       SampleArea : TRect;
                                       SampleRows : integer;
                                       SampleCols : integer);
begin
  RefA := RefArea;
  RefR := RefRows;

```

```

    sgAnalysis.Cells[GreenMaxColumn, RowInsertIndex] := FloatToStrF(GreenMax,
ffFixed, Precision, Digits);
    sgAnalysis.Cells[BlueMaxColumn, RowInsertIndex] := FloatToStrF(BlueMax,
ffFixed, Precision, Digits);
    sgAnalysis.Cells[RedMinColumn, RowInsertIndex] := FloatToStrF(RedMin,
ffFixed, Precision, Digits);
    sgAnalysis.Cells[GreenMinColumn, RowInsertIndex] := FloatToStrF(GreenMin,
ffFixed, Precision, Digits);
    sgAnalysis.Cells[BlueMinColumn, RowInsertIndex] := FloatToStrF(BlueMin,
ffFixed, Precision, Digits);
    Variation := (RedMax - RedMin) + (GreenMax - GreenMin) + (BlueMax -
BlueMin);
    sgAnalysis.Cells[VariationColumn, RowInsertIndex] := FloatToStrF(Variation,
ffFixed, Precision, Digits);
    end;
    inc(RowInsertIndex);
end;

procedure TfrmReferenceDisplay.ShowShades;
var
    ShadeIndex : integer;
    CurrentShade : TShadeColours;
begin
    RowInsertIndex := TitleRow + 1;
    for ShadeIndex := 0 to DisplayShades.ShadeList.Count - 1 do
    begin
        CurrentShade := DisplayShades.ShadeList.Items[ShadeIndex];
        InsertShadeData(CurrentShade);
    end;
end;

procedure TfrmReferenceDisplay.LoadShades(Shades : TShadeReferences);
var
    lDisplayRow : integer;
begin
    { First Clear Old list }
    if DisplayShades.ShadeList.Count > 0 then
        for lDisplayRow := 1 to DisplayShades.ShadeList.Count do
            sgAnalysis.Rows[lDisplayRow].Clear;

        //DisplayShades.Free;

        DisplayShades := Shades;
        sgAnalysis.RowCount := Shades.ShadeList.Count + 1;
        ShowShades;
    end;

procedure TfrmReferenceDisplay.edGridColChange(Sender: TObject);
begin
    if Visible then
    begin
        DisplayColumn := StrToInt(edGridCol.Text);
        ShowShades;
    end;
end;

procedure TfrmReferenceDisplay.edGridRowChange(Sender: TObject);

```

```

unit ImageDisplay;

interface

uses
  Windows, Messages, SysUtils, Classes, Graphics, Controls, Forms, Dialogs,
  TMultiP, ExtCtrls;

type
  TfrmImageDisplay = class(TForm)
    pnlImage: TPanel;
    pmiImage: TPMultiImage;
    procedure FormCreate(Sender: TObject);
    procedure pmiImagePaint(Sender: TObject);
  private
    { Private declarations }
    RefA : TRect;
    RefR : integer;
    RefC : integer;
    SampleA : TRect;
    SampleR : integer;
    SampleC : integer;
    DisplayGrid : boolean;
    procedure DrawGrid(Area : TRect; Rows, Columns : integer);
    procedure DrawGrids;
  public
    { Public declarations }
    procedure DefineGrids(RefArea: TRect;
                          RefRows : integer;
                          RefCols : integer;
                          SampleArea : TRect;
                          SampleRows : integer;
                          SampleCols : integer);
    procedure HideGrid;
  end;

var
  frmImageDisplay: TfrmImageDisplay;

implementation

{$R *.DFM}

procedure TfrmImageDisplay.DrawGrid(Area : TRect; Rows, Columns : integer);
var
  Spacing : real;
  index : integer;
  ScaleX : real;
  ScaleY : real;
  Left, Right, Top, Bottom : integer;
begin
  ScaleX := pmiImage.Width/640;
  ScaleY := pmiImage.Height/480;
  Left := Round(Area.Left * ScaleX);
  Right := Round(Area.Right * ScaleX);
  Top := Round(Area.Top * ScaleY);
  Bottom := Round(Area.Bottom * ScaleY);

```

```
RefC := RefCols;
SampleA := SampleArea;
SampleR := SampleRows;
SampleC := SampleCols;
DisplayGrid := true;
pmiImage.Repaint;
end;

procedure TfrmImageDisplay.HideGrid;
begin
  DisplayGrid := false;
  Repaint;
end;

procedure TfrmImageDisplay.pmiImagePaint(Sender: TObject);
begin
  DrawGrids;
end;

end.
```

```

NewCalibration := false;
try
  IniFile := TIniFile.Create(DiskDrive + 'Analyse\' + IniFilename);
  DefaultShadeFilename := IniFile.ReadString(IniShadeSetSection,
IniDefaultGuide, 'ERROR');
  DefaultShadeFilename := DiskDrive + 'Analyse\' + DefaultShadeFilename;
  LoadShadeSet(DefaultShadeFilename);
finally
  IniFile.Free;
end;
end;

function TfrmShadeAnalyzer.AnalyseImage(FileName : string; ShadeName : string) :
TShadeColours;
var
  ShadeColours : TShadeColours;
  Tooth : TTooth;
  DeltaRed : real;
  DeltaGreen : real;
  DeltaBlue : real;
  PixelPercent : real;
  RefArea : TRect;
  SampleArea : TRect;
begin
  Tooth := TTooth.Create;

  { Analyse The Reference Area }
  frmImageDisplay.HideGrid;
  Tooth.LoadBitmapFromFile(FileName);
  frmImageDisplay.pmiImage.Picture.Bitmap.Assign(Tooth.ToothBitmap);
  Application.ProcessMessages;

  RefArea := Tooth.FillSearchSampleLimits(frmSampleLocator.ReferenceLocation);
  frmImageDisplay.DefineGrids(RefArea, RefRows, RefColumns, Rect(0,0,0,0),
SampleRows, SampleColumns);
  Application.ProcessMessages;

  Tooth.RemoveMask(RefArea);
  frmImageDisplay.pmiImage.Picture.Bitmap.Assign(Tooth.ToothBitmap);
  Application.ProcessMessages;

  Tooth.Analyse(0, 0, RefArea, RefRows, RefColumns, DeltaRed, DeltaGreen,
DeltaBlue, PixelPercent);

  DeltaRed := RefRedMedian - DeltaRed;
  DeltaGreen := RefGreenMedian - DeltaGreen;
  DeltaBlue := RefBlueMedian - DeltaBlue;

  { Now Analyse the Sample Area }
  frmImageDisplay.HideGrid;
  Tooth.LoadBitmapFromFile(FileName);
  frmImageDisplay.pmiImage.Picture.Bitmap.Assign(Tooth.ToothBitmap);
  Application.ProcessMessages;

  SampleArea := Tooth.FillSearchSampleLimits(frmSampleLocator.SampleLocation);
  frmImageDisplay.DefineGrids(Rect(0,0,0,0), RefRows, RefColumns, SampleArea,
SampleRows, SampleColumns);

```

```

Application.ProcessMessages;

Tooth.RemoveReflection(SampleArea);
frmImageDisplay.pmiImage.Picture.Bitmap.Assign(Tooth.ToothBitmap);
Application.ProcessMessages;

ShadeColours := Tooth.AnalyseGrid(SampleArea, SampleRows, SampleColumns,
                                   DeltaRed, DeltaGreen, DeltaBlue);

ShadeColours.Name := ShadeName;
Result := ShadeColours;
Tooth.Free;
end;

procedure TfrmShadeAnalyzer.CalibrateClick(Sender: TObject);
var
  FilePath : string;
  FileIndex : integer;
  lFilename : string;
  ShadeName : string;
  ProgressBar : TProgressBar;
  ShadeColours : TShadeColours;
begin
  OpenFileDialog.Title := 'Files To Analyse';
  OpenFileDialog.InitialDir := DiskDrive + 'Analyse\Pictures\';
  OpenFileDialog.DefaultExt := GraphicExtension(TBitmap);
  OpenFileDialog.Filter := GraphicFilter(TBitmap);
  OpenFileDialog.Options := [ofAllowMultiSelect, ofPathMustExist, ofFileMustExist];
  if OpenFileDialog.Execute then
    with OpenFileDialog.Files do
      begin
        edShadeSetName.Text := 'New Calibration';
        NewCalibration := true;
        StatusBar.SimpleText := 'Loading Calibration Bitmaps';
        Shades.Free;
        Shades := TShadeReferences.Create; // we will build a new list

        FilePath := ExtractFilePath(OpenDialog.FileName);
        ProgressBar := TProgressBar.Create(self);
        ProgressBar.Parent := self;
        ProgressBar.Align := alBottom;
        ProgressBar.Min := 0;
        ProgressBar.Max := Count+2;
        ProgressBar.Step := 1; // the amount to move with the StepIt method
        for FileIndex := 0 to Count - 1 do
          begin
            lFilename := Strings[FileIndex];

            { Get the Shade Name from the filename }
            ShadeName := ExtractFilename(lFilename);
            StatusBar.SimpleText := 'Loading Calibration Bitmap '+ShadeName;
            ShadeName := UpperCase(Copy(ShadeName, 1, Pos('.', ShadeName) - 2)); //
remove the letter

            ShadeColours := AnalyseImage(lFilename, ShadeName);

            Shades.AddSample(ShadeColours);

```

```

    ProgressBar.Stepit; // Move one Step amount
end;

Application.ProcessMessages;

{ Get the Shades into alphabetical order }
StatusBar.SimpleText := 'Sorting Shade Samples';
Shades.SortList;
ProgressBar.Stepit; // Move one Step amount

{ Process the Shades Data to get average sets }
StatusBar.SimpleText := 'Reducing Shades to Reference Set';
Shades.ReduceList;
ProgressBar.Stepit; // Move one Step amount

Shades.SortList;

ProgressBar.Free;

StatusBar.SimpleText := 'Done';
end;
end;

procedure TfrmShadeAnalyzer.ShowImage1Click(Sender: TObject);
begin
    frmImageDisplay.Show;
end;

function TfrmShadeAnalyzer.FindNearestShade(Sample : tShadeColours) : string;
var
    CurrentShade : TShadeColours;
    ShadeName : string;
    ShadeDifference : real;
    CurrentDifference : real;
    ShadeIndex : integer;
begin
    ShadeDifference := 1000000;
    ShadeName := 'None';
    for ShadeIndex := 0 to Shades.ShadeList.Count - 1 do
    begin
        CurrentShade := Shades.ShadeList.Items[ShadeIndex];
        CurrentDifference := CurrentShade.ColourDifference(Sample);
        if CurrentDifference < ShadeDifference then
        begin
            ShadeName := CurrentShade.Name;
            ShadeDifference := CurrentDifference;
        end;
    end;
    result := ShadeName;
end;

procedure TfrmShadeAnalyzer.ShowReference1Click(Sender: TObject);
begin
    frmReferenceDisplay.LoadShades(Shades);
    frmReferenceDisplay.ShowModal;
end;

```

```
procedure TfrmShadeAnalyzer.SetSampleLoc1Click(Sender: TObject);
begin
  frmSampleLocator.ShowModal;
end;

procedure TfrmShadeAnalyzer.Analyse1Click(Sender: TObject);
var
  lFilename : string;
  SampleColours : TShadeColours;
  ProgressBar : TProgressBar;
begin
  OpenFileDialog.Title := 'Files To Analyse';
  OpenFileDialog.InitialDir := DiskDrive + 'Analyse\Pictures\';
  OpenFileDialog.DefaultExt := GraphicExtension(TBitmap);
  OpenFileDialog.Filter := GraphicFilter(TBitmap);
  OpenFileDialog.Options := [ofPathMustExist, ofFileMustExist];
  if OpenFileDialog.Execute then
  begin
    edNearest.Text := '';
    StatusBar.SimpleText := 'Analyzing Sample';

    ProgressBar := TProgressBar.Create(self);
    ProgressBar.Parent := self;
    ProgressBar.Align := alBottom;
    ProgressBar.Min := 0;
    ProgressBar.Max := 3;
    ProgressBar.Step := 1; // the amount to move with the StepIt method

    lFilename := OpenFileDialog.FileName;

    ProgressBar.StepIt;
    Application.ProcessMessages;

    SampleColours := AnalyseImage(lFileName, 'Unknown');

    ProgressBar.StepIt;
    Application.ProcessMessages;

    StatusBar.SimpleText := 'Searching for Nearest Shade';
    edNearest.Text := FindNearestShade(SampleColours);

    ProgressBar.StepIt;
    Application.ProcessMessages;

    StatusBar.SimpleText := 'Done';
    ProgressBar.Free;
  end;
end;

procedure TfrmShadeAnalyzer.btnSaveClick(Sender: TObject);
var
  lFilename : string;
  OutStream : TFileStream;
  IniFile : TIniFile;
begin
  SaveDialog.Title := 'Shade Guide Filename to Save';
  SaveDialog.InitialDir := DiskDrive + 'Analyse\';
```



```

SaveDialog.DefaultExt := 'SDS';
SaveDialog.Filter := 'Shade Guides|*.SDS';
SaveDialog.Options := [ofPathMustExist];
if SaveDialog.Execute then
  with SaveDialog do
  begin
    if not FileExists(Filename) or
      (MessageDlg(Format('Overwrite %s?', [ExtractFilename(Filename)]),
        mtConfirmation, [mbYes, mbNo], 0) = mrYes) then
    begin
      try
        OutStream := TFileStream.Create(Filename, fmCreate or fmShareCompat);
        Shades.SaveToStream(OutStream);
        lFilename := ExtractFilename(SaveDialog.Filename);
        edShadeSetName.Text := copy(lFilename, 1, Length(lFilename) - 4);
        NewCalibration := false;
        try
          IniFile := TIniFile.Create(DiskDrive + 'Analyse\' + IniFilename);
          IniFile.WriteString(IniShadeSetSection, IniDefaultGuide, lFilename);
        finally
          IniFile.Free;
        end;
      finally
        OutStream.Free;
      end;
    end;
  end;
end;

procedure TfrmShadeAnalyzer.LoadShadeSet(Filename : string);
var
  InStream : TFileStream;
  IniFile : TIniFile;
  lFilename : string;
begin
  try
    edShadeSetName.Text := 'Loading...';
    InStream := TFileStream.Create(Filename, fmOpenRead or fmShareCompat);
    Shades.Free;
    Shades := TShadeReferences.Create; // we will build a new list
    Shades.LoadFromStream(InStream);
    lFilename := ExtractFilename(Filename);
    edShadeSetName.Text := copy(lFilename, 1, Length(lFilename) - 4);
    try
      IniFile := TIniFile.Create(DiskDrive + 'Analyse\' + IniFilename);
      IniFile.WriteString(IniShadeSetSection, IniDefaultGuide, lFilename);
    finally
      IniFile.Free;
    end;
  finally
    InStream.Free;
  end;
end;

procedure TfrmShadeAnalyzer.btnLoadClick(Sender: TObject);
begin
  OpenDialog.Title := 'Shade Guide Set to Load';

```

```
OpenDialog.InitialDir := DiskDrive + 'Analyse\';
OpenDialog.DefaultExt := 'SDS';
OpenDialog.Filter := 'Shade Guides|*.SDS';
OpenDialog.Options := [ofPathMustExist, ofFileMustExist];
if OpenDialog.Execute then
  LoadShadeSet(OpenDialog.FileName);
end;

procedure TfrmShadeAnalyzer.FormClose(Sender: TObject;
  var Action: TCloseAction);
begin
  { Closing Program - Check for unsaved Calibration Set }
  if (NewCalibration) and
    (MessageDlg('Calibration Load Not Saved. Save Now?',
      mtConfirmation, [mbYes, mbNo], 0) = mrYes) then
    btnSaveClick(self);
end;

procedure TfrmShadeAnalyzer.FormActivate(Sender: TObject);
begin
  if Startup then
    begin
      Startup := false;
      frmSplashScreen.Show;
      Application.ProcessMessages;

      {$IFDEF SLIDELOGO}
        frmSplashScreen.Timer1.Interval := 1000;
      {$ELSE}
        frmSplashScreen.Timer1.Interval := 3000;
      {$ENDIF}
    end;
end;

end.
```

```

unit SplashScreen;

interface

uses
  Windows, Messages, SysUtils, Classes, Graphics, Controls, Forms, Dialogs,
  ExtCtrls, TMultiP;

type
  TSplashState = (splCenter, splMoving, splDone);

  TfrmSplashScreen = class(TForm)
    Timer1: TTimer;
    pnlLogo: TPanel;
    Image1: TImage;
    procedure Timer1Timer(Sender: TObject);
    procedure FormCreate(Sender: TObject);
    procedure FormPaint(Sender: TObject);
  private
    { Private declarations }
    SplashState : TSplashState;
    StartPosition : TPoint;
    StartSize : TPoint;
    VerticalStep : integer;
    HorizontalStep : integer;
    WidthStep : integer;
    HeightStep : integer;
    CanPaint : boolean;
  public
    { Public declarations }
  end;

var
  frmSplashScreen: TfrmSplashScreen;

implementation

{$R *.DFM}

const
  FinishPosition : TPoint = (x:580; y:700);
  FinishSize      : TPoint = (x:430; y:50);
  Duration        = 2000; // ms
  MoveInterval    = 50;   // ms

procedure TfrmSplashScreen.Timer1Timer(Sender: TObject);
begin
  {$IFDEF SLIDELOGO}
  if abs(FinishPosition.x - Left) < abs(HorizontalStep) then
    HorizontalStep := HorizontalStep div abs(HorizontalStep);
  if abs(FinishPosition.Y - Top) < abs(VirticalStep) then
    VirticalStep := VirticalStep div abs(VirticalStep);

  if abs(FinishSize.x - Width) < abs(WidthStep) then
    WidthStep := WidthStep div abs(WidthStep);
  if abs(FinishSize.Y - Height) < abs(HeightStep) then
    HeightStep := HeightStep div abs(HeightStep);
  
```

```

CanPaint := false;

case SplashState of
  splCenter:
    begin
      Timer1.Interval := MoveInterval;
      SplashState := splMoving;
    end;
  splMoving:
    begin
      if (Top = FinishPosition.y) and (Left = FinishPosition.x) and
        (Height = FinishSize.y) and (Width = FinishSize.x) then
        SplashState := splDone
      else
        begin
          if Top <> FinishPosition.y then
            Top := Top + VerticalStep;
          if Left <> FinishPosition.x then
            Left := Left + HorizontalStep;
          if Height <> FinishSize.y then
            Height := Height + HeightStep;
          if Width <> FinishSize.x then
            Width := Width + WidthStep;
        end;
      end;
    splDone:
      begin
        Timer1.Enabled := false;
      end;
    end;
  CanPaint := true;
{$ELSE}
  Height := FinishSize.y;
  Width := FinishSize.x;
  Top := FinishPosition.y;
  Left := FinishPosition.x;
  pnlLogo.BevelWidth := 2;
{$ENDIF}
end;

procedure TfrmSplashScreen.FormCreate(Sender: TObject);
begin
  SplashState := splCenter;
  StartPosition.x := Left;
  StartPosition.y := Top;
  StartSize.x := Width;
  StartSize.y := Height;
  //VerticalStep := (FinishPosition.y - StartPosition.y) div (Duration div
  MoveInterval);
  //HorizontalStep := (FinishPosition.x - StartPosition.x) div (Duration div
  MoveInterval);
  //HeightStep := (FinishSize.y - StartSize.y) div (Duration div MoveInterval);
  //WidthStep := (FinishSize.x - StartSize.x) div (Duration div MoveInterval);
  VerticalStep := 1;
  HorizontalStep := 1;
  HeightStep := -1;

```

```
WidthStep := -1;
CanPaint := true;
end;

procedure TfrmSplashScreen.FormPaint(Sender: TObject);
begin
  if CanPaint then
    Image1.Repaint;
end;

end.
```

```

unit ToothObject;

interface

uses
  Windows, SysUtils, Classes, Graphics,
  ShadeData;

type
  TTooth = class(TObject)
  private
    ReferenceInitialised : boolean;
    function CalculateTestArea(Row, Col : integer;
      Area : TRect;
      NoRows, NoCols : integer) : TRect;

  public
    Red : real;
    Green : real;
    Blue : real;
    Hue : real;
    Saturation : real;
    Intensity : real;
    RefRed : real;
    RefGreen : real;
    RefBlue : real;
    RefHue : real;
    RefSaturation : real;
    RefIntensity : real;
    ToothBitmap : TBitmap;
    ToothBitmapMask : TBitmap;
    constructor Create;
    procedure Free;
    procedure LoadBitmapFromFile(Filename : String);
    procedure RemoveReflection(TestArea : TRect);
    procedure RemoveMask(TestArea : TRect);
    function FillSearchSampleLimits(StartPoint : TPoint) : TRect;
    procedure Analyse(Row, Col : integer;
      Area : TRect; NoRows, NoCols : integer;
      var R, G, B : real;
      var PixelPercentage : real);
    function AnalyseGrid(Area : TRect; NoRows, NoCols : integer;
      DeltaRed, DeltaGreen, DeltaBlue : real) :
      TShadeColours;
    procedure CalculateHSI(R, G, B : real; var Hue, Sat, Int : real);
  end;

implementation

uses
  Dialogs, Math;

const
  RedMask   : longint   = $000000FF;
  GreenMask : longint   = $0000FF00;

```

```

BlueMask : longint      = $00FF0000;

BoundryIntensity      = 0.58; // sum of RGB
ReflectionIntensity   = 1.86;

type
  TDirection = (Up, Down, Left, Right);

constructor TTooth.Create;
begin
  ToothBitmap := TBitmap.Create;
  ToothBitmap.Width := 640;
  ToothBitmap.Height := 480;
  ToothBitmapMask := TBitmap.Create;
  ToothBitmapMask.Width := 640;
  ToothBitmapMask.Height := 480;
  ReferenceInitialised := false;
end;

procedure TTooth.Free;
begin
  ToothBitmap.Free;
  ToothBitmapMask.Free;
  Inherited Free;
end;

function TTooth.FillSearchSampleLimits(StartPoint : TPoint) : TRect;
  procedure FillSearch(StartpointX, StartpointY : integer);
  var
    Red, Green, Blue : integer;
    x, y : integer;
  begin
    if StartpointX > Result.Right then
      Result.Right := StartpointX;
    if StartpointX < Result.Left then
      Result.Left := StartpointX;
    if StartpointY > Result.Bottom then
      Result.Bottom := StartpointY;
    if StartpointY < Result.Top then
      Result.Top := StartpointY;

    for x := -1 to 1 do
      for y := -1 to 1 do
        if (StartpointX+x < 640) and (StartpointX+x > 0) and
           (StartpointY+y < 480) and (StartpointY+y > 0) and
           (ToothBitmapMask.Canvas.Pixels[StartpointX+x, StartpointY+y] <> 0)
        then
          begin
            Red := ToothBitmap.Canvas.Pixels[StartpointX+x, StartpointY+y] and
RedMask;
            Green := (ToothBitmap.Canvas.Pixels[StartpointX+x, StartpointY+y] and
GreenMask) shr 8;
            Blue := (ToothBitmap.Canvas.Pixels[StartpointX+x, StartpointY+y] and
BlueMask) shr 16;
            if ((Red + Green + Blue)/255) > BoundryIntensity then
              begin
                ToothBitmapMask.Canvas.Pixels[StartpointX+x, StartpointY+y] := 0;
              end;
          end;
        end;
      end;
    end;
  end;
end;

```

```

        FillSearch(StartpointX+x, StartpointY+y);
    end
end;
end;
begin
    Result := Rect(640, 480, 0, 0);
    FillSearch(StartPoint.X, StartPoint.Y);
end;

function TTooth.CalculateTestArea(Row, Col : integer;
    Area : TRect;
    NoRows, NoCols : integer) : TRect;

var
    TestArea : TRect;
    ColSpacing : real;
    RowSpacing : real;
begin
    with Area do
    begin
        ColSpacing := (Right - Left) / NoCols;
        RowSpacing := (Bottom - Top) / NoRows;
        TestArea.Top := Top + Trunc(RowSpacing * Row);
        TestArea.Bottom := Top + Trunc(RowSpacing * (Row + 1));
        TestArea.Left := Left + Trunc(ColSpacing * Col);
        TestArea.Right := Left + Trunc(ColSpacing * (Col + 1));
    end;

    CalculateTestArea := TestArea;
end; // CalculateTestArea

procedure TTooth.RemoveReflection(TestArea : TRect);
var
    i : integer;
    j : integer;
    Red, Green, Blue : integer;
begin
    with TestArea do
    for i := Left to Right do
        for j := Top to Bottom do
            begin
                if (ToothBitMapMask.Canvas.Pixels[i,j] <> 0) then
                    ToothBitMap.Canvas.Pixels[i,j] := 0
                else
                    begin
                        Red := ToothBitMap.Canvas.Pixels[i,j] and RedMask;
                        Green := (ToothBitMap.Canvas.Pixels[i,j] and GreenMask) shr 8;
                        Blue := (ToothBitMap.Canvas.Pixels[i,j] and BlueMask) shr 16;

                        if ((Red + Green + Blue) / 255 > ReflectionIntensity) then
                            ToothBitMap.Canvas.Pixels[i,j] := 0;
                        end;
                    end;
                end;
            end;
        end;
    end;

end; // RemoveReflection

procedure TTooth.RemoveMask(TestArea : TRect);

```



```

var
  i : integer;
  j : integer;
begin
  with TestArea do
    for i := Left to Right do
      for j := Top to Bottom do
        if (ToothBitMapMask.Canvas.Pixels[i,j] <> 0) then
          ToothBitMap.Canvas.Pixels[i,j] := 0;
        end;
      end;
    end;
  end; // RemoveReflection

procedure TTooth.Analyse(Row, Col : integer;
  Area : TRect; NoRows, NoCols : integer;
  var R, G, B : real;
  var PixelPercentage : real);
var
  TestArea : TRect;
  PixelCount : longint;

  i : integer;
  j : integer;
  RedTotal : longint;
  GreenTotal : longint;
  BlueTotal : longint;
  Red, Green, Blue : integer;
begin
  TestArea := CalculateTestArea(Row, Col, Area, NoRows, NoCols);
  with TestArea do
    PixelCount := (Right - Left + 1) * (Bottom - Top + 1);

    // Now average ignoring reflections and blemishes
    RedTotal := 0;
    GreenTotal := 0;
    BlueTotal := 0;

    with TestArea do
      for i := Left to Right do
        for j := Top to Bottom do
          begin
            if ToothBitMap.Canvas.Pixels[i,j] <> 0 then
              begin
                Red := ToothBitMap.Canvas.Pixels[i,j] and RedMask;
                Green := (ToothBitMap.Canvas.Pixels[i,j] and GreenMask) shr 8;
                Blue := (ToothBitMap.Canvas.Pixels[i,j] and BlueMask) shr 16;

                RedTotal := RedTotal + Red;
                GreenTotal := GreenTotal + Green;
                BlueTotal := BlueTotal + Blue;
              end
            else
              begin
                PixelCount := PixelCount - 1; // Ignored this pixel
              end;
            end;
          end;
        end;
      end;
    end;
  end;
end;

```

```

// Normalised RGB
if PixelCount > 0 then
begin
  R := RedTotal / PixelCount / 255;
  G := GreenTotal / PixelCount / 255;
  B := BlueTotal / PixelCount / 255;
  with TestArea do
    PixelPercentage := PixelCount / ((Bottom-Top+1)*(Right - Left+1));
end
else
begin
  R := 0;
  G := 0;
  B := 0;
  PixelPercentage := 0;
end;
end; // Analyse

function TTooth.AnalyseGrid(Area : TRect;
                           NoRows, NoCols : integer;
                           DeltaRed, DeltaGreen, DeltaBlue : real) :
TShadeColours;
var
  Row, Col : integer;
  Red, Green, Blue, PixelPercent : real;
begin
  Result := TShadeColours.Create;

  for Row := 0 to NoRows - 1 do
    for Col := 0 to NoCols - 1 do
      begin
        Analyse(Row, Col, Area, NoRows, NoCols,
               Red, Green, Blue, PixelPercent);
        Result.GridColours[Col+1, Row+1] := TShadeColourElement.Create;
        Result.GridColours[Col+1, Row+1].StoreColour(Red + DeltaRed,
                                                       Green + DeltaGreen,
                                                       Blue + DeltaBlue,
                                                       PixelPercent);
      end;
    end;
  end;

procedure TTooth.CalculateHSI(R, G, B : real; var Hue, Sat, Int : real);

function Minimum (v1, v2, v3 : real) : real;
begin
  if (v1 <= v2) and (v1 <= v3) then
    minimum := v1
  else
    if (v2 <= v1) and (v2 <= v3) then
      Minimum := v2
    else
      Minimum := v3;
  end;

function Maximum (v1, v2, v3 : real) : real;
begin
  if (v1 >= v2) and (v1 >= v3) then

```

```
        Maximum := v1
    else
        if (v2 >= v1) and (v2 >= v3) then
            Maximum := v2
        else
            Maximum := v3;
    end;
end;

begin
    // Calculation using Gonzalez and Woods
    Int := (R + G + B) / 3;

    if Int > 0 then
        begin
            Sat := 1 - (3 / (R + G + B)) * Minimum(R,G,B);
            Hue := arccos((((R-G)+(R-B))/2)/sqrt(sqr(R-G)+((R-B)*(G-B)))) / (2*pi);
            if (B / Int) > (G / Int) then
                Hue := 1 - Hue;
            end
        else
            begin
                Sat := 0;
                Hue := 0;
            end;
        end;
    end; // CalculateHSI

procedure TTooth.LoadBitmapFromFile(Filename : String);
begin
    ToothBitmap.LoadFromFile(Filename);
    ToothBitmap.Dormant;
    ToothBitmapMask.Assign(ToothBitmap);
end; // LoadBitmapFromFile

end.
```

```
unit RefDisplay;

interface

uses
  Windows, Messages, SysUtils, Classes, Graphics, Controls, Forms, Dialogs,
  Grids, ShadeData, ComCtrls, StdCtrls, ExtCtrls;

type
  TfrmReferenceDisplay = class(TForm)
    Panel1: TPanel;
    sgAnalysis: TStringGrid;
    Panel2: TPanel;
    edGridCol: TEdit;
    udGridCol: TUpDown;
    edGridRow: TEdit;
    udGridRow: TUpDown;
    Label1: TLabel;
    Label2: TLabel;
    Label3: TLabel;
    procedure FormCreate(Sender: TObject);
    procedure InsertShadeData(Shade : TShadeColours);
    procedure edGridColChange(Sender: TObject);
    procedure LoadShades(Shades : TShadeReferences);
    procedure edGridRowChange(Sender: TObject);
  private
    { Private declarations }
    RowInsertIndex : integer;
    DisplayRow : integer;
    DisplayColumn : integer;
    DisplayShades : TShadeReferences;
    procedure ShowShades;
  public
    { Public declarations }
  end;

var
  frmReferenceDisplay: TfrmReferenceDisplay;

implementation

{$R *.DFM}

const
  TitleRow = 0;
  NameColumn = 0;
  RedColumn = NameColumn + 1;
  GreenColumn = RedColumn + 1;
  BlueColumn = GreenColumn + 1;
  VariationColumn = BlueColumn + 1;
  RedMaxColumn = VariationColumn + 1;
  RedMinColumn = RedMaxColumn + 1;
  GreenMaxColumn = RedMinColumn + 1;
  GreenMinColumn = GreenMaxColumn + 1;
  BlueMaxColumn = GreenMinColumn + 1;
  BlueMinColumn = BlueMaxColumn + 1;
```

```

Precision = 6;
Digits = 4;

procedure TfrmReferenceDisplay.FormCreate(Sender: TObject);
begin
  { Configure the Grid to Display the Reference Set }
  DisplayColumn := GridWidth div 2;
  DisplayRow := GridHeight div 2;

  udGridCol.Min := 1;
  udGridCol.Max := GridWidth;

  udGridRow.Min := 1;
  udGridRow.Max := GridHeight;

  udGridRow.Position := DisplayRow;
  udGridCol.Position := DisplayColumn;

  edGridCol.Text := IntToStr(DisplayColumn);
  edGridRow.Text := IntToStr(DisplayRow);

  sgAnalysis.ColCount := 11;
  sgAnalysis.RowCount := 17; // may change

  RowInsertIndex := TitleRow + 1;
  sgAnalysis.Cells[NameColumn, TitleRow] := 'Shade';
  sgAnalysis.Cells[RedColumn, TitleRow] := 'Red';
  sgAnalysis.Cells[GreenColumn, TitleRow] := 'Green';
  sgAnalysis.Cells[BlueColumn, TitleRow] := 'Blue';
  sgAnalysis.Cells[VariationColumn, TitleRow] := 'Variation';
  sgAnalysis.Cells[RedMaxColumn, TitleRow] := 'Max Red';
  sgAnalysis.Cells[GreenMaxColumn, TitleRow] := 'Max Green';
  sgAnalysis.Cells[BlueMaxColumn, TitleRow] := 'Max Blue';
  sgAnalysis.Cells[RedMinColumn, TitleRow] := 'Min Red';
  sgAnalysis.Cells[GreenMinColumn, TitleRow] := 'Min Green';
  sgAnalysis.Cells[BlueMinColumn, TitleRow] := 'Min Blue';

  DisplayShades := TShadeReferences.Create;
end;

procedure TfrmReferenceDisplay.InsertShadeData(Shade : TShadeColours);
var
  Variation : real;
begin
  with Shade.GridColours[DisplayColumn, DisplayRow] do
  begin
    sgAnalysis.Cells[NameColumn, RowInsertIndex] := Shade.Name;
    sgAnalysis.Cells[RedColumn, RowInsertIndex] := FloatToStrF(Red, ffFixed,
Precision, Digits);
    sgAnalysis.Cells[GreenColumn, RowInsertIndex] := FloatToStrF(Green, ffFixed,
Precision, Digits);
    sgAnalysis.Cells[BlueColumn, RowInsertIndex] := FloatToStrF(Blue, ffFixed,
Precision, Digits);
    sgAnalysis.Cells[RedMaxColumn, RowInsertIndex] := FloatToStrF(RedMax,
ffFixed, Precision, Digits);

```

```
begin
  IniFile.WriteString(IniReferenceSection, IniRefX, IntToStr(X));
  IniFile.WriteString(IniReferenceSection, IniRefY, IntToStr(Y));
end;

with SampleLocation do
begin
  IniFile.WriteString(IniSampleSection, IniSampleX, IntToStr(X));
  IniFile.WriteString(IniSampleSection, IniSampleY, IntToStr(Y));
end;
finally
  IniFile.Free;
end;
end;

Close;
end;

procedure TfrmSampleLocator.btnLoadSampleClick(Sender: TObject);
begin
  OpenFileDialog.Title := 'Sample Image To Display';
  OpenFileDialog.InitialDir := Copy(ParamStr(0), 0, 3) + 'Analyse\Pictures\';
  OpenFileDialog.DefaultExt := GraphicExtension(TBitmap);
  OpenFileDialog.Filter := GraphicFilter(TBitmap);
  OpenFileDialog.Options := [ofPathMustExist, ofFileMustExist];
  if OpenFileDialog.Execute then
  begin
    pmiImage.Picture.LoadFromFile(OpenDialog.FileName);
  end;
end;

procedure TfrmSampleLocator.pmiImageClick(Sender: TObject);
begin
  { Check Location Option and Update The Location Co Ords }
  if rgLocation.ItemIndex = 0 then
  begin
    edRefX.Text := edXPos.Text;
    edRefY.Text := edYPos.Text;
  end
  else
  begin
    edSampleX.Text := edXPos.Text;
    edSampleY.Text := edYPos.Text;
  end;
end;

procedure TfrmSampleLocator.FormShow(Sender: TObject);
begin
  edRefX.Text := IntToStr(ReferenceLocation.x);
  edRefY.Text := IntToStr(ReferenceLocation.y);
  edSampleX.Text := IntToStr(SampleLocation.x);
  edSampleY.Text := IntToStr(SampleLocation.y);
end;

procedure TfrmSampleLocator.btnCancelClick(Sender: TObject);
begin
  Close;
end;
```

```
unit SampleLocator;

interface

uses
  Windows, Messages, SysUtils, Classes, Graphics, Controls, Forms, Dialogs,
  TMultiP, ExtCtrls, StdCtrls;

type
  TfrmSampleLocator = class(TForm)
    Panel1: TPanel;
    pmiImage: TPMultiImage;
    OpenDialog: TOpenDialog;
    btnLoadSample: TButton;
    edXPos: TEdit;
    Label1: TLabel;
    edYPos: TEdit;
    Label2: TLabel;
    rgLocation: TRadioGroup;
    Panel2: TPanel;
    Label3: TLabel;
    Label4: TLabel;
    edRefX: TEdit;
    Label5: TLabel;
    edRefY: TEdit;
    Label6: TLabel;
    edSampleX: TEdit;
    Label7: TLabel;
    edSampleY: TEdit;
    Label8: TLabel;
    btnSave: TButton;
    btnCancel: TButton;
    procedure pmiImageMouseMove(Sender: TObject; Shift: TShiftState; X,
      Y: Integer);
    procedure FormCreate(Sender: TObject);
    procedure btnSaveClick(Sender: TObject);
    procedure btnLoadSampleClick(Sender: TObject);
    procedure pmiImageClick(Sender: TObject);
    procedure FormShow(Sender: TObject);
    procedure btnCancelClick(Sender: TObject);
  private
    { Private declarations }
  public
    { Public declarations }
    ReferenceLocation : TPoint;
    SampleLocation : TPoint;

  end;

var
  frmSampleLocator: TfrmSampleLocator;

implementation

{$R *.DFM}
```

```
uses
  SDIMain, IniFiles;

procedure TfrmSampleLocator.pmiImageMouseMove(Sender: TObject;
  Shift: TShiftState; X, Y: Integer);
begin
  edXPos.Text := IntToStr(X);
  edYPos.Text := IntToStr(Y);
end;

procedure TfrmSampleLocator.FormCreate(Sender: TObject);
var
  IniFile : TIniFile;
begin
  { Load The Saved Sample Location From Ini File }
  { Set Default for now }
  ReferenceLocation := Point(170, 40);
  SampleLocation := Point(300, 160);

  if FileExists(frmShadeAnalyzer.DiskDrive + 'Analyse\' + IniFileName) then
  begin
    try
      IniFile := TIniFile.Create(frmShadeAnalyzer.DiskDrive + 'Analyse\' +
        IniFileName);

      with ReferenceLocation do
      begin
        X := StrToInt(IniFile.ReadString(IniReferenceSection, IniRefX, 'ERROR'));
        Y := StrToInt(IniFile.ReadString(IniReferenceSection, IniRefY, 'ERROR'));
      end;

      with SampleLocation do
      begin
        X := StrToInt(IniFile.ReadString(IniSampleSection, IniSampleX, 'ERROR'));
        Y := StrToInt(IniFile.ReadString(IniSampleSection, IniSampleY, 'ERROR'));
      end;
    finally
      IniFile.Free;
    end;
  end;
end;

procedure TfrmSampleLocator.btnSaveClick(Sender: TObject);
var
  IniFile : TIniFile;
begin
  ReferenceLocation := point(StrToInt(edRefX.Text), StrToInt(edRefY.Text));
  SampleLocation := point(StrToInt(edSampleX.Text), StrToInt(edSampleY.Text));

  if FileExists(frmShadeAnalyzer.DiskDrive + 'Analyse\' + IniFileName) then
  begin
    try
      IniFile := TIniFile.Create(frmShadeAnalyzer.DiskDrive + 'Analyse\' +
        IniFileName);

      with ReferenceLocation do
```



end;

end.

```
unit Sdimain;

interface

uses Windows, Classes, Graphics, Forms, Controls, Menus,
    Dialogs, StdCtrls, Buttons, ExtCtrls, ComCtrls,
    ShadeData;

const
    IniFilename           = 'ShadeAnalyse.ini';

    IniReferenceSection  = 'REFERENCE AREA';
    IniRefX               = 'RefAreaX';
    IniRefY               = 'RefAreaY';

    IniSampleSection     = 'SAMPLE AREA';
    IniSampleX           = 'SampleAreaX';
    IniSampleY           = 'SampleAreaY';

    IniShadeSetSection   = 'DEFAULT GUIDE';
    IniDefaultGuide      = 'GuideFilename';

    Startup : Boolean     = true; // used for splash screen

type
    TfrmShadeAnalyzer = class(TForm)
        SDIAppMenu: TMainMenu;
        FileMenu: TMenuItem;
        ExitItem: TMenuItem;
        N1: TMenuItem;
        OpenDialog: TOpenDialog;
        Help1: TMenuItem;
        About1: TMenuItem;
        StatusBar: TStatusBar;
        Calibrate: TMenuItem;
        Options1: TMenuItem;
        ShowImage1: TMenuItem;
        ShowReference1: TMenuItem;
        SetSampleLoc1: TMenuItem;
        Analyse1: TMenuItem;
        gbShadeSet: TGroupBox;
        btnLoad: TButton;
        btnSave: TButton;
        edShadeSetName: TEdit;
        gbSampleAnalysis: TGroupBox;
        btnMatch: TButton;
        Label1: TLabel;
        edNearest: TEdit;
        SaveDialog: TSaveDialog;
        procedure ShowHint(Sender: TObject);
        procedure About1Click(Sender: TObject);
        procedure FormCreate(Sender: TObject);
        procedure CalibrateClick(Sender: TObject);
        procedure ShowImage1Click(Sender: TObject);
        procedure ShowReference1Click(Sender: TObject);
        procedure SetSampleLoc1Click(Sender: TObject);
        procedure Analyse1Click(Sender: TObject);
    end;
end;
```

```

procedure btnSaveClick(Sender: TObject);
procedure btnLoadClick(Sender: TObject);
procedure FormClose(Sender: TObject; var Action: TCloseAction);
procedure FormActivate(Sender: TObject);
private
  { Private declarations }
  Shades : TShadeReferences;
  function AnalyseImage(FileName : string; ShadeName : string) :
TShadeColours;
  function FindNearestShade(Sample : tShadeColours) : string;
  procedure LoadShadeSet(Filename : string);
public
  { Public declarations }
  DiskDrive : string;
  NewCalibration : boolean;
end;

var
  frmShadeAnalyzer: TfrmShadeAnalyzer;

implementation

uses
  SysUtils, About, IniFiles,
  ToothObject, ImageDisplay, RefDisplay, SampleLocator, SplashScreen;

{$R *.DFM}

const
  RefRedMedian = 0.5432;
  RefGreenMedian = 0.6308;
  RefBlueMedian = 0.3355;

  RefRows = 1;
  RefColumns = 1;
  SampleRows = GridHeight; // To change see Shade Data
  SampleColumns = GridWidth;

procedure TfrmShadeAnalyzer.ShowHint(Sender: TObject);
begin
  StatusBar.SimpleText := Application.Hint;
end;

procedure TfrmShadeAnalyzer.About1Click(Sender: TObject);
begin
  AboutBox.ShowModal;
end;

procedure TfrmShadeAnalyzer.FormCreate(Sender: TObject);
var
  IniFile : TIniFile;
  DefaultShadeFilename : string;
begin
  Application.OnHint := ShowHint;
  DiskDrive := Copy(ParamStr(0),0,3);
  Shades := TShadeReferences.Create; // we will build a new list

```

```
begin
  if Visible then
    begin
      DisplayRow := StrToInt(edGridRow.Text);
      ShowShades;
    end;
  end;
end.
end.
```

```

unit ShadeData;

{
  The Shade reference is divided into a grid. Each area of the grid is
  analysed, and the average Red, Green and Blue values are stored. If there
  is an edge element in the sample, the valid flag is set to ignore the
  area in correlation matches.
}

interface

  uses
    Classes;

const
  GridWidth = 10;
  GridHeight = 10;

type
  PShadeColourElement = ^TShadeColourElement;
  TShadeColourElement = class(TObject)
    Red : real48;           // Average red content
    Green : real48;        // Average green content
    Blue : real48;         // Average blue content
    Valid : boolean;       // Valid for comparison
    ValidPixelPercent : real48; // 0..1 (1 = all pixels

used)

    RedDev : real48;
    GreenDev : real48;
    BlueDev : real48;
    RedMax : real48;
    RedMin : real48;
    GreenMax : real48;
    GreenMin : real48;
    BlueMax : real48;
    BlueMin : real48;
    constructor Create;
    function ColourDifference (ShadeColour :
TShadeColourElement) : real48;
    procedure StoreColour(R,G,B : real48; Percent :
real);
    procedure AddColour(R,G,B : real48; Percent : real);
    function ValidCell : boolean;
    procedure SaveToStream(OutStream : TStream);
    procedure LoadFromStream(InStream : TStream);
  private
  end;

  PShadeColours = ^TShadeColours;
  TShadeColours = class(TObject)
    Name : string;           // Name of the Shade reference
etc.
    GridColours : array[1..GridWidth, 1..GridHeight] of
TShadeColourElement;
    function ColourDifference(ShadeColours : TShadeColours) :
real48;
    procedure SaveToStream(OutStream : TStream);

```

```

        procedure LoadFromStream(InStream : TStream);
    private
    end;

TShadeReferences = class(TObject)
    ShadeList : TList;
    constructor Create;
    procedure AddSample(Sample : TShadeColours);
    procedure Clear;
    procedure SortList;
    procedure ReduceList;
    procedure SaveToStream(OutStream : TStream);
    procedure LoadFromStream(InStream : TStream);
    private
    end;

implementation

uses
    SysUtils, Dialogs, Controls;

const
    ValidityLimit          = 0.95; // 95% of pixels must be used

constructor TShadeColourElement.Create;
begin
    Red := 0;
    Green := 0;
    Blue := 0;
    ValidPixelPercent := 0;
    Valid := false;
    RedDev := 0;
    GreenDev := 0;
    BlueDev := 0;
    RedMax := 0;
    RedMin := 1000;
    GreenMax := 0;
    GreenMin := 1000;
    BlueMax := 0;
    BlueMin := 1000;
end;

procedure TShadeColourElement.StoreColour(R,G,B : real48; Percent : real);
begin
    Red := R;
    Green := G;
    Blue := B;
    ValidPixelPercent := Percent;
    Valid := (Percent >= ValidityLimit);
end;

procedure TShadeColourElement.AddColour(R,G,B : real48; Percent : real);
begin
    if R > RedMax then RedMax := R;
    if G > GreenMax then GreenMax := G;
    if B > BlueMax then BlueMax := B;

```

```

if R < RedMin then RedMin := R;
if G < GreenMin then GreenMin := G;
if B < BlueMin then BlueMin := B;
Red := Red + R;
Green := Green + G;
Blue := Blue + B;
end;

function TShadeColourElement.ValidCell : boolean;
begin
  Result := Valid;
end;

function TShadeColourElement.ColourDifference(ShadeColour : TShadeColourElement)
: real48;
var
  DistanceRed : real48;
  DistanceGreen : real48;
  DistanceBlue : real48;
begin
  if (Valid) and (ShadeColour.Valid) then
  begin
    DistanceRed:=(Red - ShadeColour.Red);
    DistanceGreen:=(Green - ShadeColour.Green);
    DistanceBlue:=(Blue - ShadeColour.Blue);
    Result := sqrt(sqr(DistanceRed) +
                  sqr(DistanceGreen) +
                  sqr(DistanceBlue));
  end
  else
    Result := -1; // cannot compare if any element is invalid
  end;
end;

procedure TShadeColourElement.SaveToStream(OutStream : TStream);
begin
  OutStream.WriteBuffer(Red, SizeOf(Red));
  OutStream.WriteBuffer(Green, SizeOf(Green));
  OutStream.WriteBuffer(Blue, SizeOf(Blue));
  OutStream.WriteBuffer(Valid, SizeOf(Valid));
  OutStream.WriteBuffer(ValidPixelPercent, SizeOf(ValidPixelPercent));
  OutStream.WriteBuffer(RedDev, SizeOf(RedDev));
  OutStream.WriteBuffer(GreenDev, SizeOf(GreenDev));
  OutStream.WriteBuffer(BlueDev, SizeOf(BlueDev));
  OutStream.WriteBuffer(RedMax, SizeOf(RedMax));
  OutStream.WriteBuffer(RedMin, SizeOf(RedMin));
  OutStream.WriteBuffer(GreenMax, SizeOf(GreenMax));
  OutStream.WriteBuffer(GreenMin, SizeOf(GreenMin));
  OutStream.WriteBuffer(BlueMax, SizeOf(BlueMax));
  OutStream.WriteBuffer(BlueMin, SizeOf(BlueMin));
end;

procedure TShadeColourElement.LoadFromStream(InStream : TStream);
begin
  InStream.ReadBuffer(Red, SizeOf(Red));
  InStream.ReadBuffer(Green, SizeOf(Green));
  InStream.ReadBuffer(Blue, SizeOf(Blue));
  InStream.ReadBuffer(Valid, SizeOf(Valid));

```

```

InStream.ReadBuffer(ValidPixelPercent, SizeOf(ValidPixelPercent));
InStream.ReadBuffer(RedDev, SizeOf(RedDev));
InStream.ReadBuffer(GreenDev, SizeOf(GreenDev));
InStream.ReadBuffer(BlueDev, SizeOf(BlueDev));
InStream.ReadBuffer(RedMax, SizeOf(RedMax));
InStream.ReadBuffer(RedMin, SizeOf(RedMin));
InStream.ReadBuffer(GreenMax, SizeOf(GreenMax));
InStream.ReadBuffer(GreenMin, SizeOf(GreenMin));
InStream.ReadBuffer(BlueMax, SizeOf(BlueMax));
InStream.ReadBuffer(BlueMin, SizeOf(BlueMin));
end;

function TShadeColours.ColourDifference(ShadeColours : TShadeColours) : real48;
var
  DifferenceGrid : array[1..GridWidth, 1..GridHeight] of real48;
  WidthIndex : integer;
  HeightIndex : integer;
  MatchedCells : integer;
begin
  Result := 0;
  MatchedCells := 0;

  { Compare each grid positions colour }
  for WidthIndex := 1 to GridWidth do
    for HeightIndex := 1 to GridHeight do
      begin
        DifferenceGrid[WidthIndex, HeightIndex] := GridColours[WidthIndex,
HeightIndex].ColourDifference(ShadeColours.GridColours[WidthIndex,
HeightIndex]);
        end;

        {
        Calculate the Colour Difference for the whole Shade
        initially just sum the differences
        Possibly just return the standard deviation or something.
        }
      for WidthIndex := 1 to GridWidth do
        for HeightIndex := 1 to GridHeight do
          if DifferenceGrid[WidthIndex, HeightIndex] <> -1 then
            begin
              Result := Result + Sqr(DifferenceGrid[WidthIndex, HeightIndex]);
              inc(MatchedCells);
            end;
          Result := Sqrt(Result/MatchedCells);
        end;
      end;

procedure TShadeColours.SaveToStream(OutStream : TStream);
var
  WidthIndex : integer;
  HeightIndex : integer;
  StringLength : integer;
begin
  StringLength := Length(Name);
  OutStream.WriteBuffer(StringLength, SizeOf(StringLength));
  OutStream.WriteBuffer(Name[1], StringLength);
  for WidthIndex := 1 to GridWidth do
    for HeightIndex := 1 to GridHeight do

```



```

        GridColours[WidthIndex, HeightIndex].SaveToStream(OutStream);
end;

procedure TShadeColours.LoadFromStream(InStream : TStream);
var
    WidthIndex : integer;
    HeightIndex : integer;
    StringLength : integer;
begin
    InStream.ReadBuffer(StringLength, SizeOf(StringLength));
    SetLength(Name, StringLength);
    InStream.ReadBuffer(Name[1], StringLength);
    for WidthIndex := 1 to GridWidth do
        for HeightIndex := 1 to GridHeight do
            begin
                GridColours[WidthIndex, HeightIndex] := TShadeColourElement.Create;
                GridColours[WidthIndex, HeightIndex].LoadFromStream(InStream);
            end;
        end;
    end;

procedure TShadeReferences.AddSample(Sample : TShadeColours);
begin
    ShadeList.Add(Sample);
end;

procedure TShadeReferences.Clear;
begin
    ShadeList.Clear;
end;

constructor TShadeReferences.Create;
begin
    ShadeList := TList.Create;
end;

function SortCompare(Item1, Item2: pointer): Integer;
begin
    if TShadeColours(Item1).Name < TShadeColours(Item2).Name then
        Result := -1
    else if TShadeColours(Item1).Name > TShadeColours(Item2).Name then
        Result := 1
    else
        Result := 0;
end;

procedure TShadeReferences.SortList;
begin
    ShadeList.Sort(SortCompare);
end;

procedure TShadeReferences.ReduceList;
var
    AverageShadeColours : TShadeColours;
    AveragedShades : TList;
    CurrentShade : TShadeColours;
    ShadeIndex : integer;
    Row, Col : integer;

```

```

AverageCount : array[1..GridWidth, 1..GridHeight] of integer;
begin
  { For each individually Named shade, average all values into one ShadeColours
  }
// New(AverageShadeColours);

AveragedShades := TList.Create;

//New(CurrentShade);
CurrentShade := TShadeColours.Create;
CurrentShade.Name := '';

for ShadeIndex := 1 to ShadeList.Count do
begin
  if CurrentShade.Name <> TShadeColours(ShadeList.Items[ShadeIndex-1]).Name
then
  begin
    if ShadeIndex <> 1 then
    begin
      { Save the last shade and start a new one }
      for Col := 1 to GridWidth do
        for Row := 1 to GridHeight do
          if AverageCount[Col, Row] <> 0 then
            with AverageShadeColours.GridColours[Col, Row] do
              begin
                Red := Red / AverageCount[Col, Row];
                Green := Green / AverageCount[Col, Row];
                Blue := Blue / AverageCount[Col, Row];
                ValidPixelPercent := ValidPixelPercent / AverageCount[Col, Row];
              end;
            AveragedShades.Add(AverageShadeColours);
          end;

          {This is a new Shade}
          AverageShadeColours := TShadeColours.Create;
          for Col := 1 to GridWidth do
            for Row := 1 to GridHeight do
              begin
                AverageShadeColours.GridColours[Col,Row] :=
TShadeColourElement.Create;
                AverageCount[Col, Row] := 0;
              end;
            AverageShadeColours.Name:= TShadeColours(ShadeList.Items[ShadeIndex-
1]).Name;
          end;

          CurrentShade := ShadeList.Items[ShadeIndex-1];

          for Col := 1 to GridWidth do
            for Row := 1 to GridHeight do
              begin
                with AverageShadeColours.GridColours[Col, Row] do
                  begin
                    if CurrentShade.GridColours[Col, Row].Valid then
                      begin
                        Valid := true;

```

```

        AddColour(CurrentShade.GridColours[Col, Row].Red,
                  CurrentShade.GridColours[Col, Row].Green,
                  CurrentShade.GridColours[Col, Row].Blue,
                  CurrentShade.GridColours[Col, Row].ValidPixelPercent);
//      ValidPixelPercent := ValidPixelPercent +
CurrentShade.GridColours[Col, Row].ValidPixelPercent;
//      Red := Red + CurrentShade.GridColours[Col, Row].Red;
//      Green := Green + CurrentShade.GridColours[Col, Row].Green;
//      Blue := Blue + CurrentShade.GridColours[Col, Row].Blue;
//      inc(AverageCount[Col, Row]);
    end;
  end;
end;

{ Save the last shade }
for Col := 1 to GridWidth do
  for Row := 1 to GridHeight do
    if AverageCount[Col, Row] <> 0 then
      with AverageShadeColours.GridColours[Col, Row] do
        begin
          Red := Red / AverageCount[Col, Row];
          Green := Green / AverageCount[Col, Row];
          Blue := Blue / AverageCount[Col, Row];
          ValidPixelPercent := ValidPixelPercent / AverageCount[Col, Row];
        end;
      end;
    end;
  end;
end;

AveragedShades.Add(AverageShadeColours);

ShadeList.Free;
ShadeList := AveragedShades;
end;

procedure TShadeReferences.SaveToStream(OutStream : TStream);
var
  ShadeIndex : integer;
  CurrentShade : TShadeColours;
begin
  ShadeIndex := ShadeList.Count; // First write the number of Shade in the set
  OutStream.WriteBuffer(ShadeIndex, SizeOf(ShadeIndex));
  for ShadeIndex := 0 to ShadeList.Count - 1 do
    begin
      CurrentShade := ShadeList.Items[ShadeIndex];
      CurrentShade.SaveToStream(OutStream);
    end;
  end;
end;


procedure TShadeReferences.LoadFromStream(InStream : TStream);
var
  NumberOfShades : integer;
  ShadeIndex : integer;
  CurrentShade : TShadeColours;
begin
  InStream.ReadBuffer(NumberOfShades, SizeOf(NumberOfShades));
  for ShadeIndex := 0 to NumberOfShades - 1 do
    begin
      CurrentShade := TShadeColours.Create;
    end;
  end;
end;

```

```
CurrentShade.LoadFromStream(InStream);  
AddSample(CurrentShade);  
end;  
end;  
end.
```

INTERNATIONAL SEARCH REPORT

International application No.  
PCT/US99/22857

<b>A. CLASSIFICATION OF SUBJECT MATTER</b> IPC(7) :A61C 5/00 US CL :433/29, 215, 223 According to International Patent Classification (IPC) or to both national classification and IPC		
<b>B. FIELDS SEARCHED</b> Minimum documentation searched (classification system followed by classification symbols) U.S. : 433/29, 215, 223 Documentation searched other than minimum documentation to the extent that such documents are included in the fields searched Electronic data base consulted during the international search (name of data base and, where practicable, search terms used)		
<b>C. DOCUMENTS CONSIDERED TO BE RELEVANT</b>		
Category*	Citation of document, with indication, where appropriate, of the relevant passages	Relevant to claim No.
X	US 5,273,429 A (REKOW et al.) 28 December 1993, col. 7 lines 9-62.	1-19
X,P	US 5,851,115 A (CARLSSON et al.) 22 December 1998, col. 5 lines 1-49.	1-19
<input type="checkbox"/> Further documents are listed in the continuation of Box C. <input type="checkbox"/> See patent family annex.		
* "A"	document defining the general state of the art which is not considered to be of particular relevance	"T" later document published after the international filing date or priority date and not in conflict with the application but cited to understand the principle or theory underlying the invention
* "E"	earlier document published on or after the international filing date	"X" document of particular relevance; the claimed invention cannot be considered novel or cannot be considered to involve an inventive step when the document is taken alone
* "L"	document which may throw doubts on priority claim(s) or which is cited to establish the publication date of another citation or other special reason (as specified)	"Y" document of particular relevance; the claimed invention cannot be considered to involve an inventive step when the document is combined with one or more other such documents, such combination being obvious to a person skilled in the art
* "O"	document referring to an oral disclosure, use, exhibition or other means	"&" document member of the same patent family
* "P"	document published prior to the international filing date but later than the priority date claimed	
Date of the actual completion of the international search 23 MARCH 2000		Date of mailing of the international search report 14 APR 2000
Name and mailing address of the ISA/US Commissioner of Patents and Trademarks Box PCT Washington, D.C. 20231 Facsimile No. (703) 305-3230		Authorized officer  NICK LUCCHESI Telephone No. (703) 308-2698