



US011168476B1

(12) **United States Patent**
Tadros et al.

(10) **Patent No.:** **US 11,168,476 B1**
(45) **Date of Patent:** **Nov. 9, 2021**

(54) **ULTRA HIGH PERFORMANCE CONCRETE
VOIDED SLAB PANELS**

(71) Applicant: **e.Construct.USA, LLC**, Omaha, NE
(US)

(72) Inventors: **Maheer K. Tadros**, Omaha, NE (US);
Micheal Asaad, Omaha, NE (US);
Bradley Schipper, Valley, NE (US)

(73) Assignee: **e.Construct.USA, LLC**, Omaha, NE
(US)

(*) Notice: Subject to any disclaimer, the term of this
patent is extended or adjusted under 35
U.S.C. 154(b) by 0 days.

(21) Appl. No.: **16/802,183**

(22) Filed: **Feb. 26, 2020**

Related U.S. Application Data

(60) Provisional application No. 62/810,568, filed on Feb.
26, 2019.

(51) **Int. Cl.**
E04B 5/04 (2006.01)
E04B 5/48 (2006.01)

(52) **U.S. Cl.**
CPC **E04B 5/043** (2013.01); **E04B 5/48**
(2013.01)

(58) **Field of Classification Search**
CPC E04B 5/043; E04B 5/48
See application file for complete search history.

(56) **References Cited**

U.S. PATENT DOCUMENTS

5,317,846 A *	6/1994	Michlovic	E04B 5/40 52/220.2
8,919,057 B1 *	12/2014	Dupray	E04B 5/36 52/223.14
2003/0097806 A1 *	5/2003	Brown	E04B 5/04 52/220.1
2009/0064617 A1 *	3/2009	Montoya	E04B 5/043 52/309.12
2016/0355439 A1 *	12/2016	McCandlish	C04B 28/188
2017/0058517 A1 *	3/2017	Mohle	E04B 1/003
2017/0218614 A1 *	8/2017	Ciuperca	E04G 17/0658

* cited by examiner

Primary Examiner — Brian Handville

(74) *Attorney, Agent, or Firm* — Suiter Swantz pc llo

(57) **ABSTRACT**

An ultra high performance concrete (UHPC) voided slab panel may include a top slab including a top skin and a bottom slab including a bottom skin. The top slab and the bottom slab may be joined at a joint filled with a joint material and positioned a select height within the UHPC voided slab panel. The top slab and the bottom slab may be joined via a connector assembly. The panel may include least two ribs defining at least one void accessible via at least one opening through an exterior surface of the UHPC voided slab panel. The UHPC voided slab panel may be fabricated from UHPC and a plurality of embedded prestressing strands, and may be configured to meet select strength requirements that are greater than select strength requirements for conventional precast concrete without reinforcing bars being embedded within the UHPC voided slab panel.

20 Claims, 15 Drawing Sheets

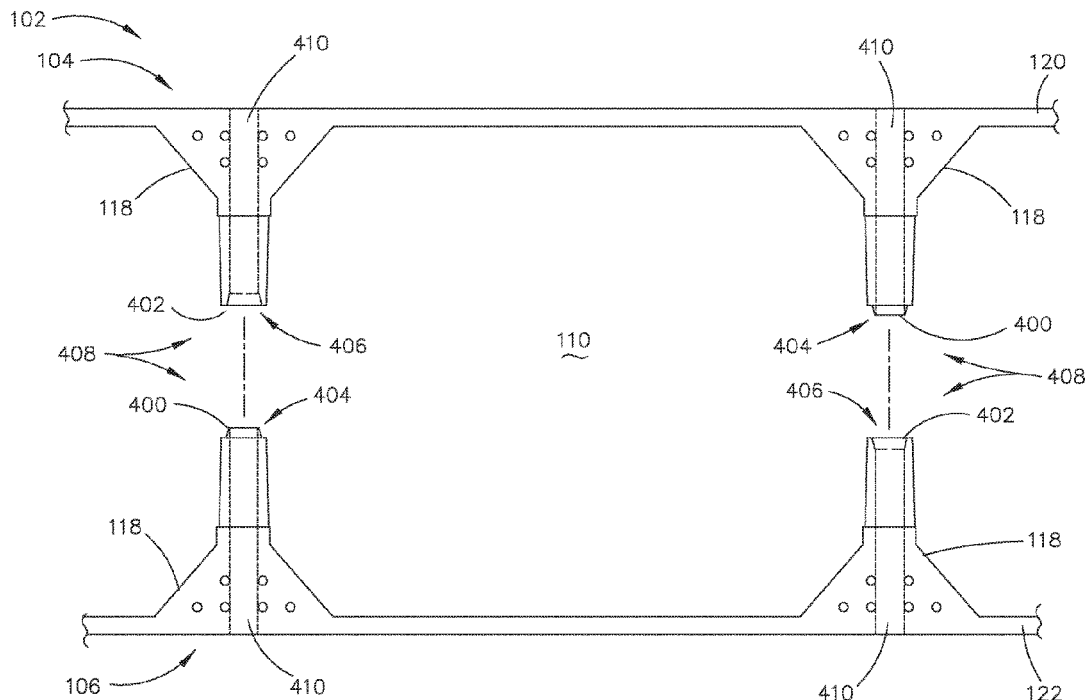

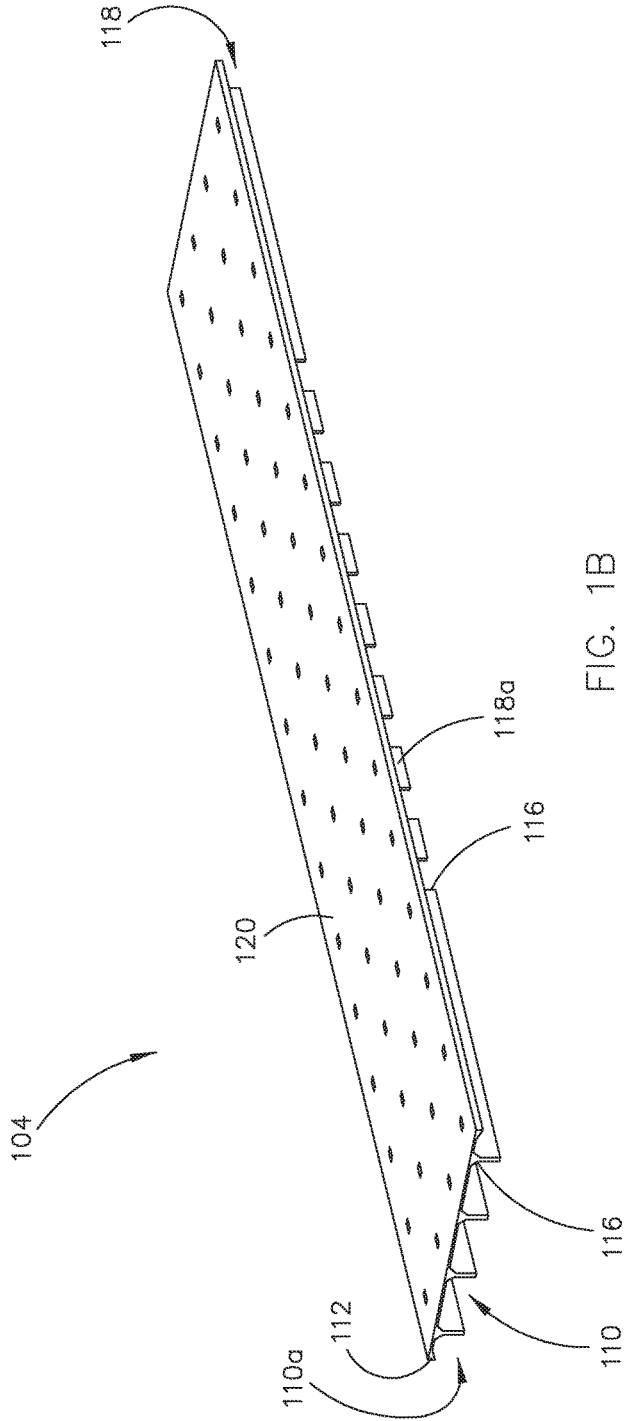

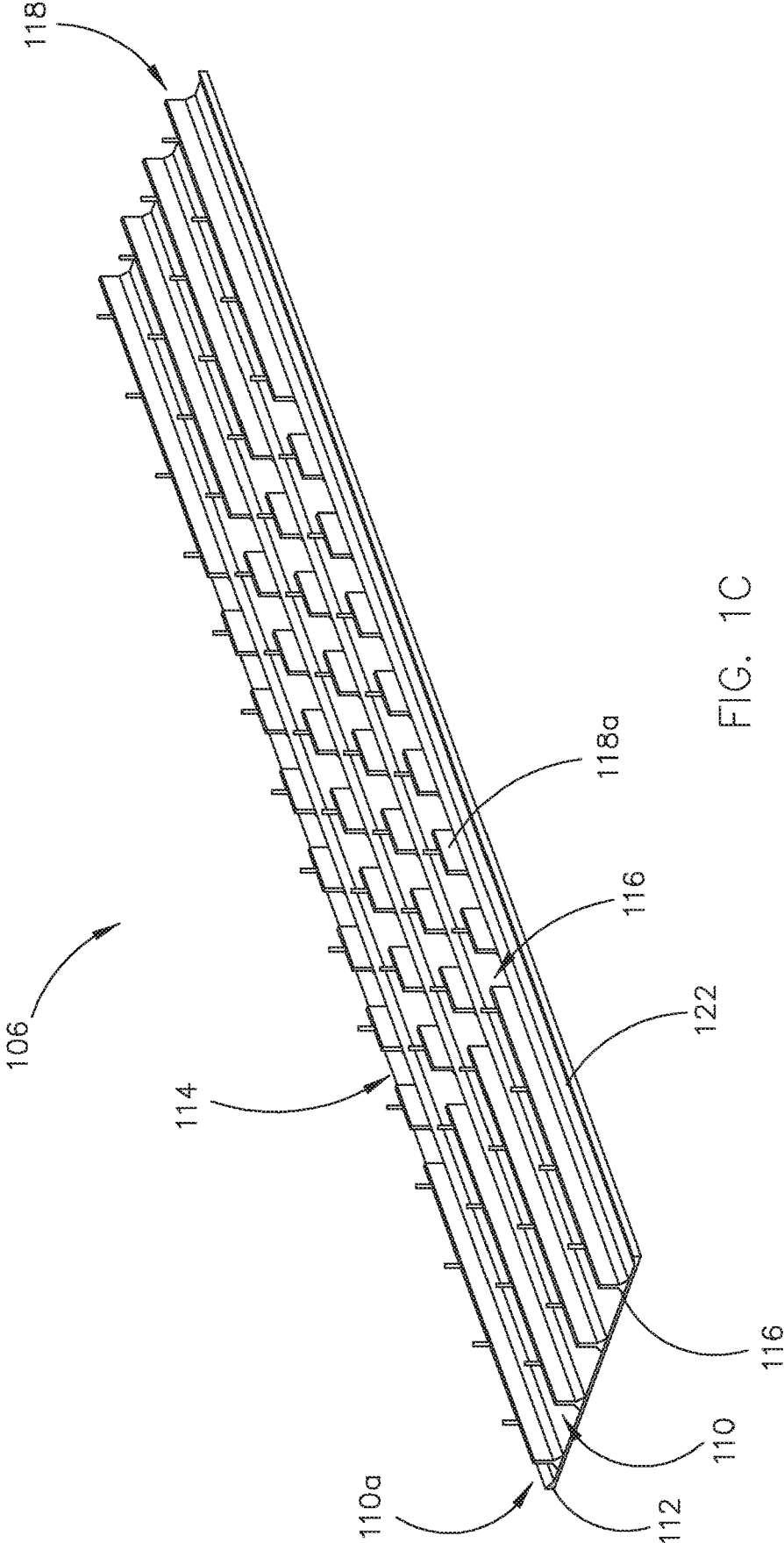

FIG. 1C

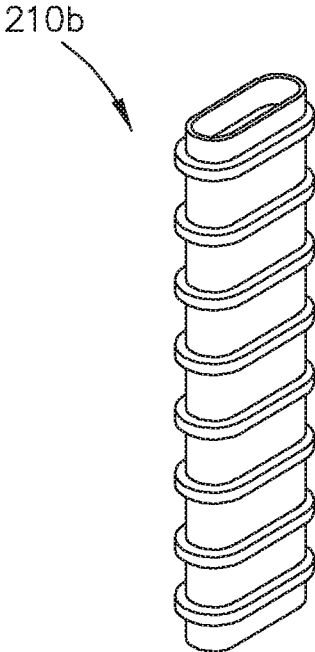
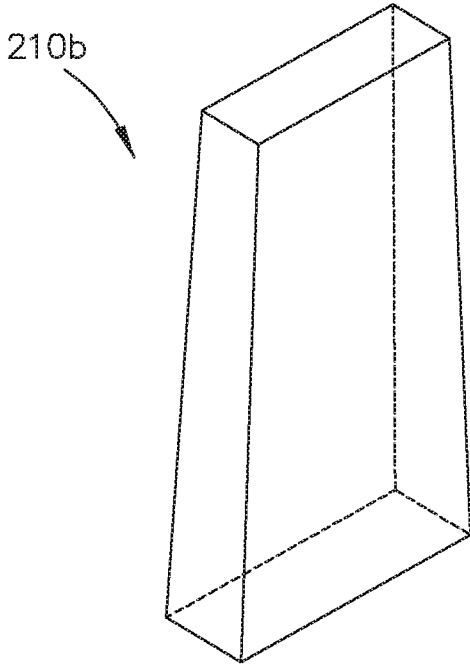
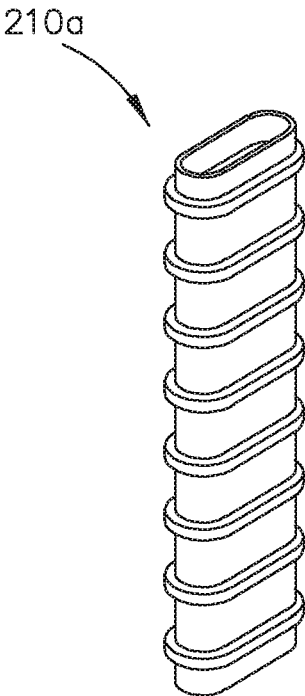
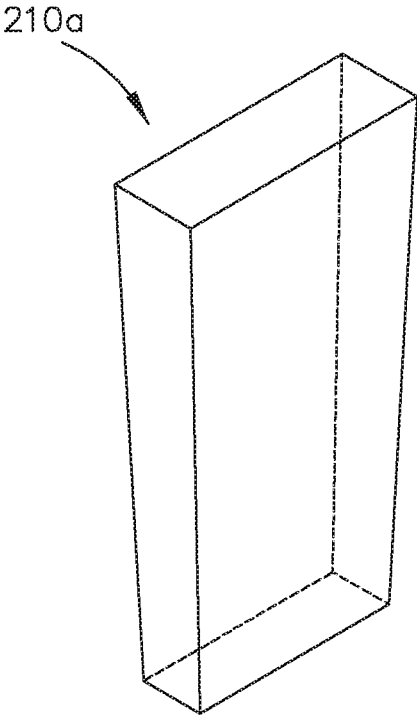

FIG. 3A

FIG. 3B

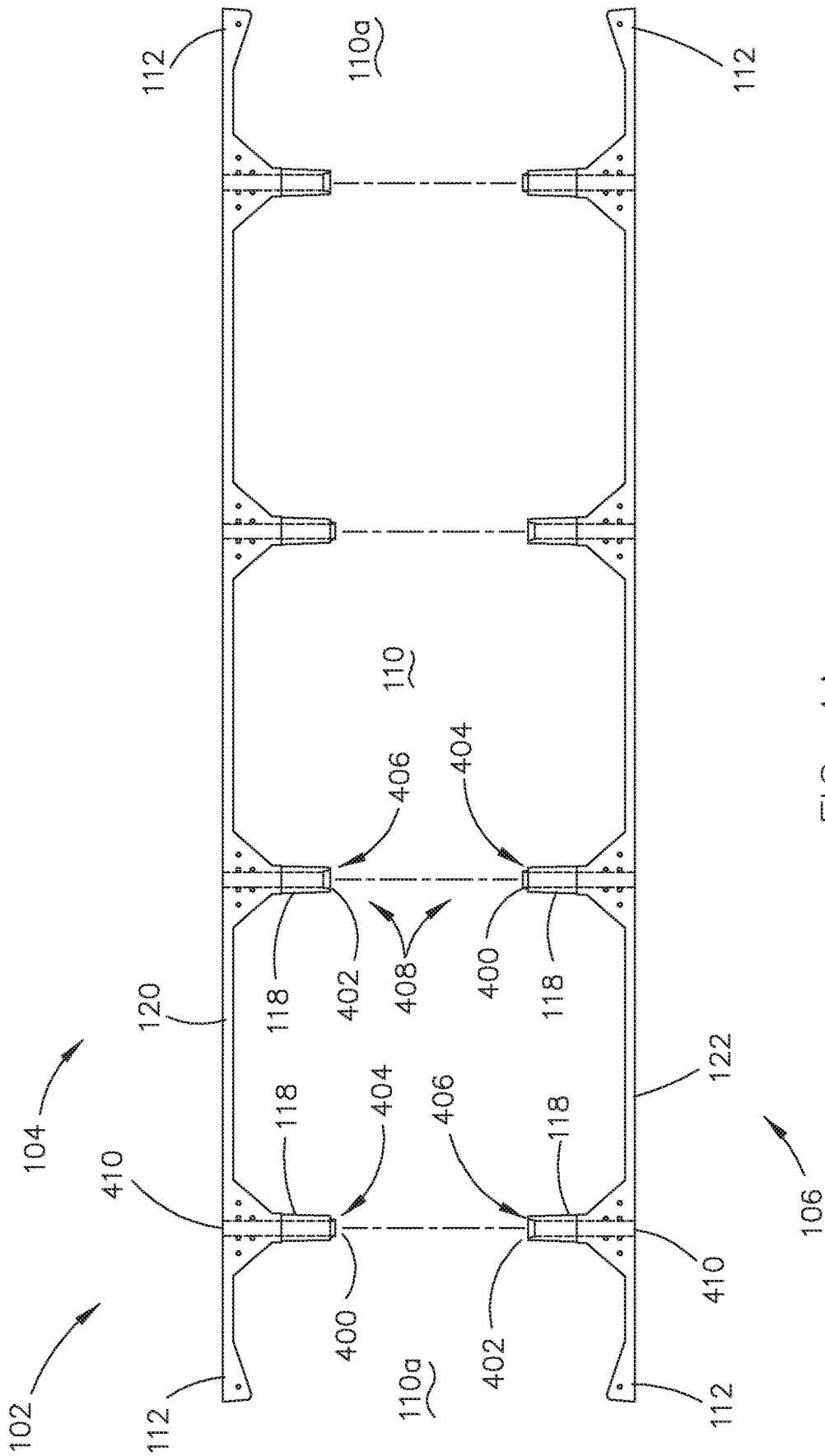
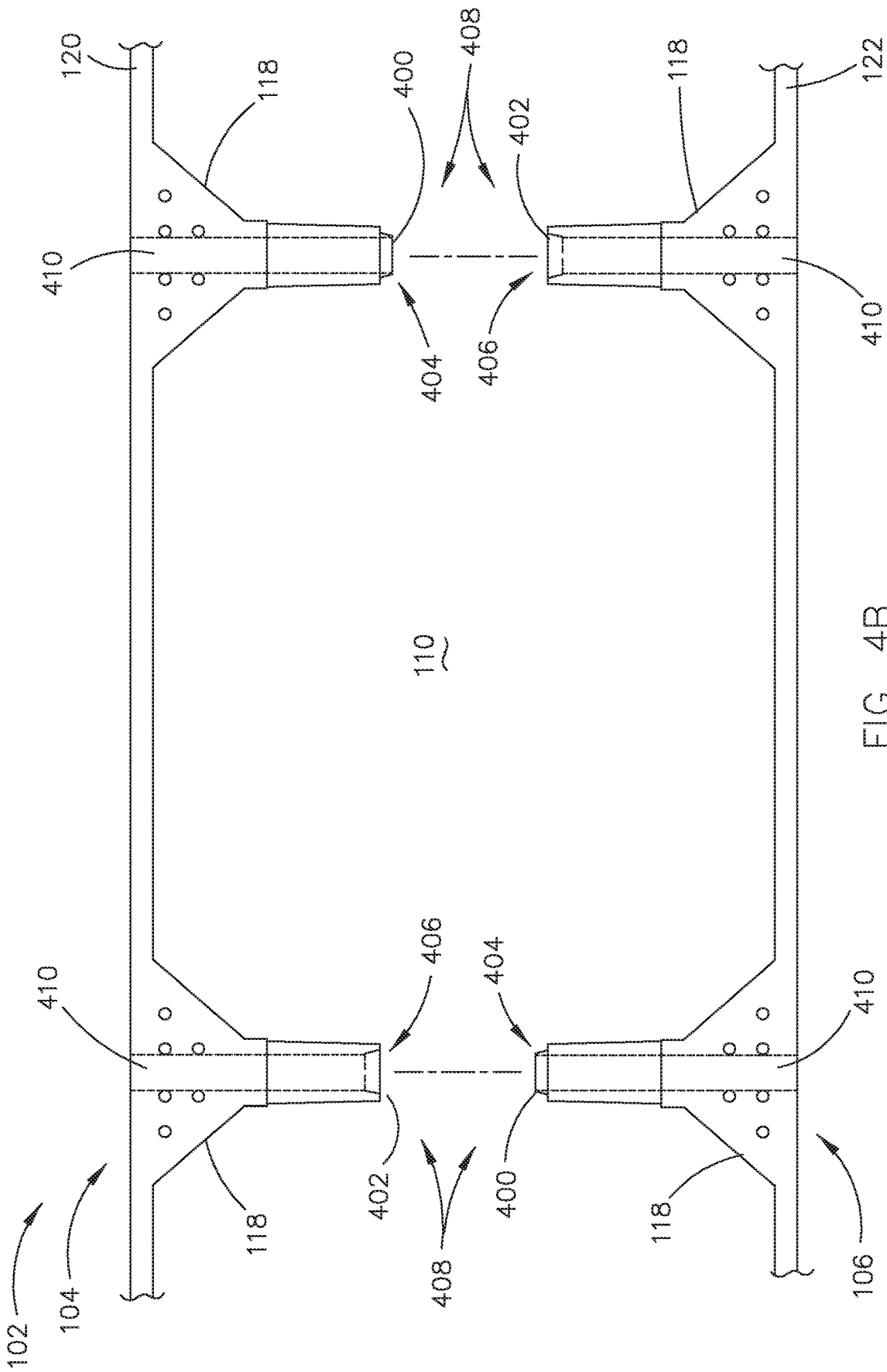

FIG. 4A



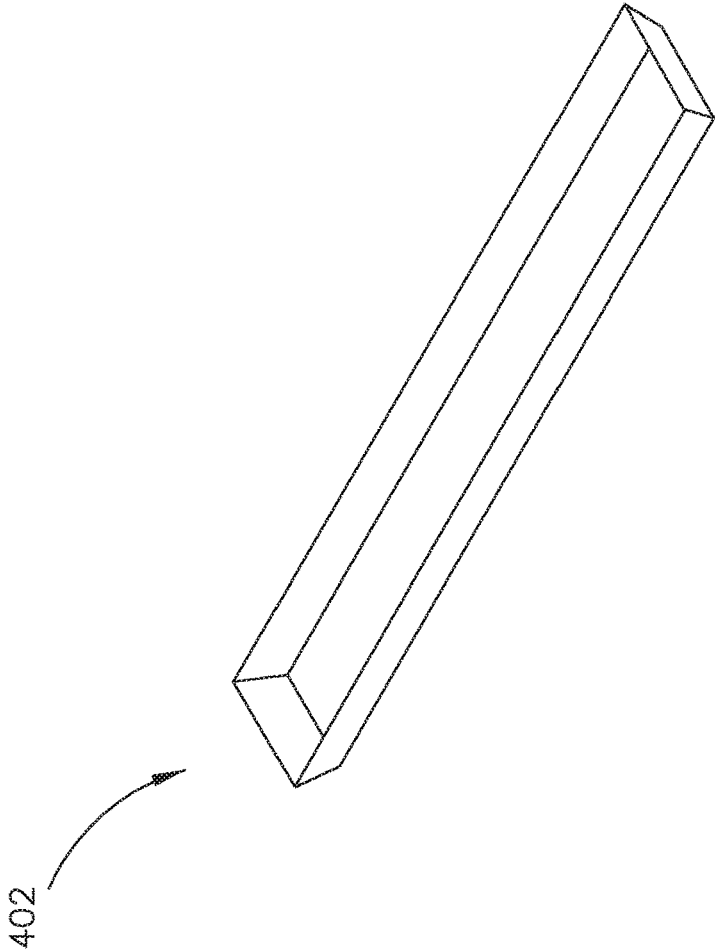

FIG. 4D

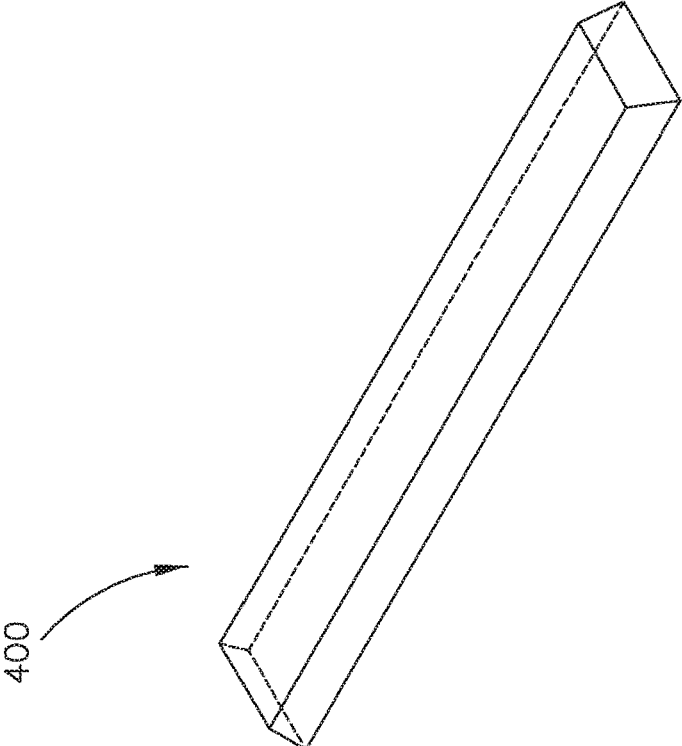

FIG. 4C

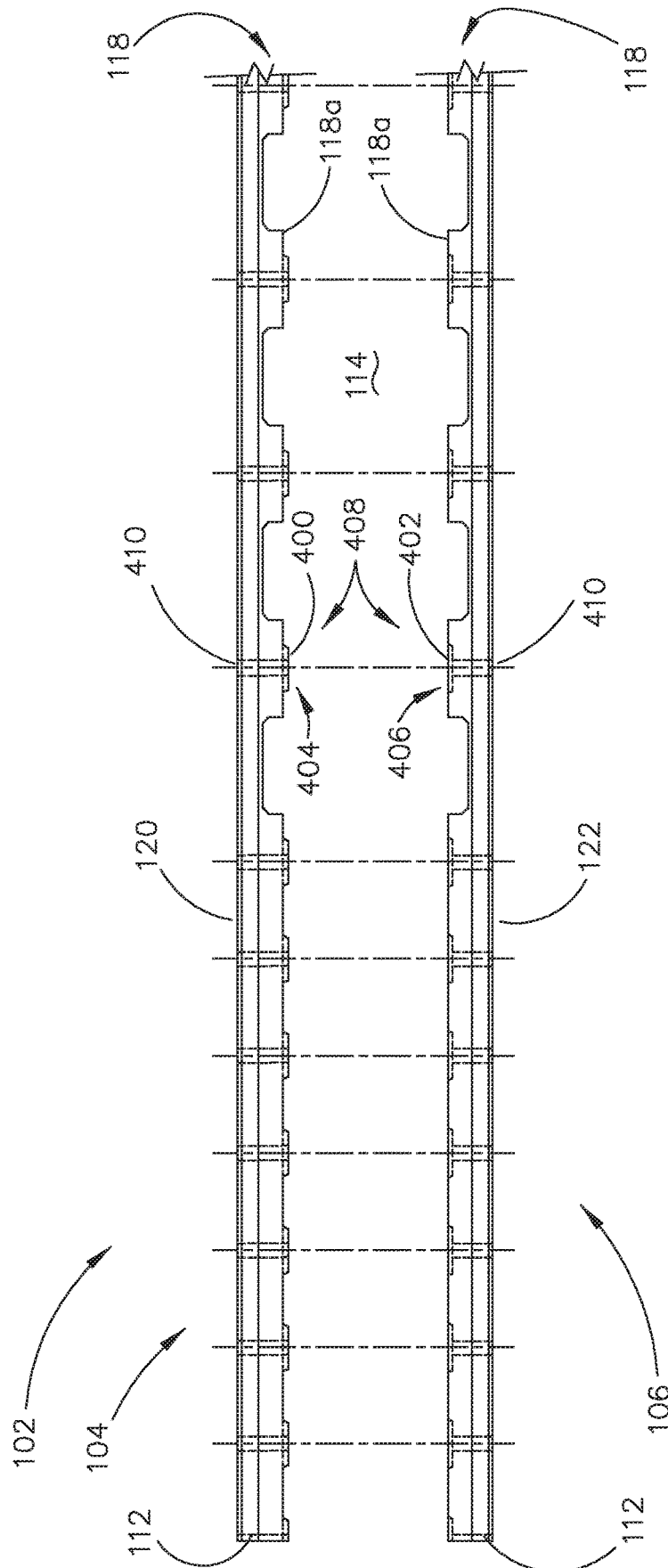

FIG. 5

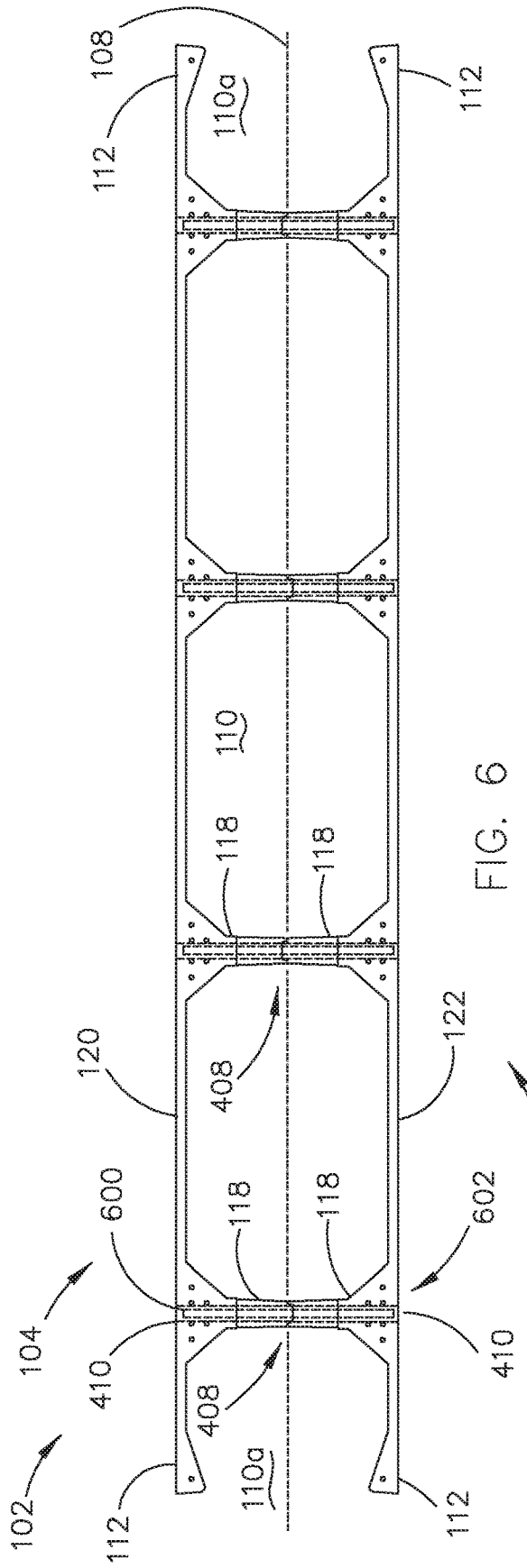

FIG. 6

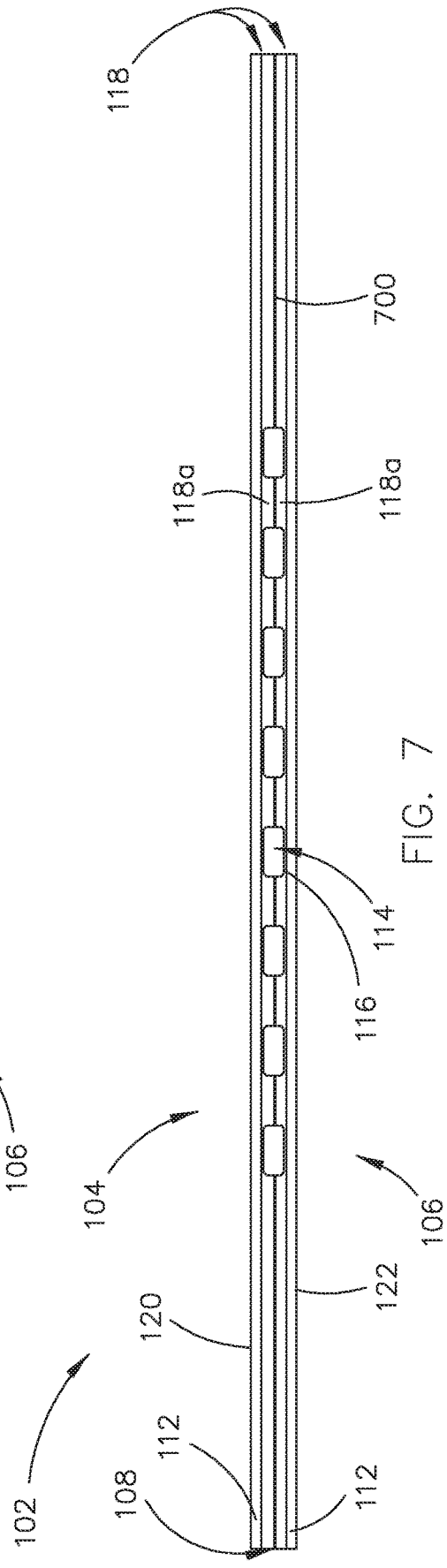
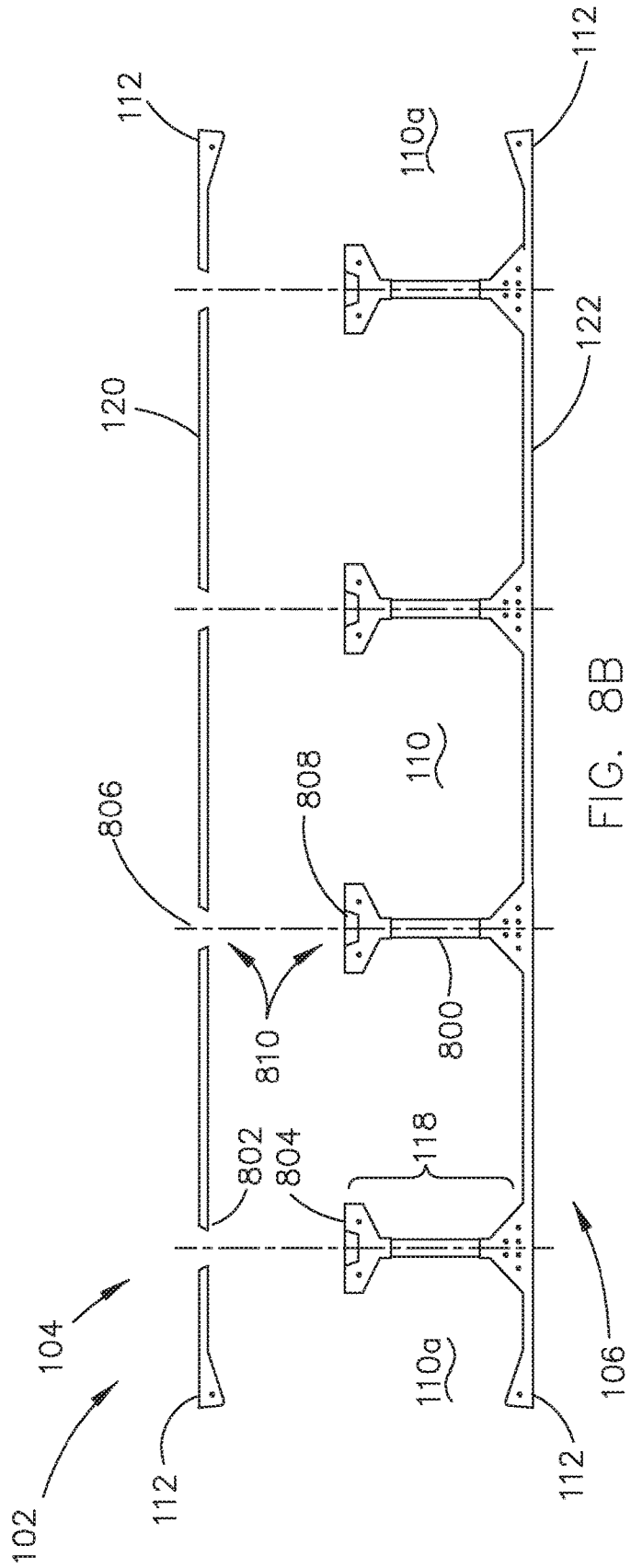
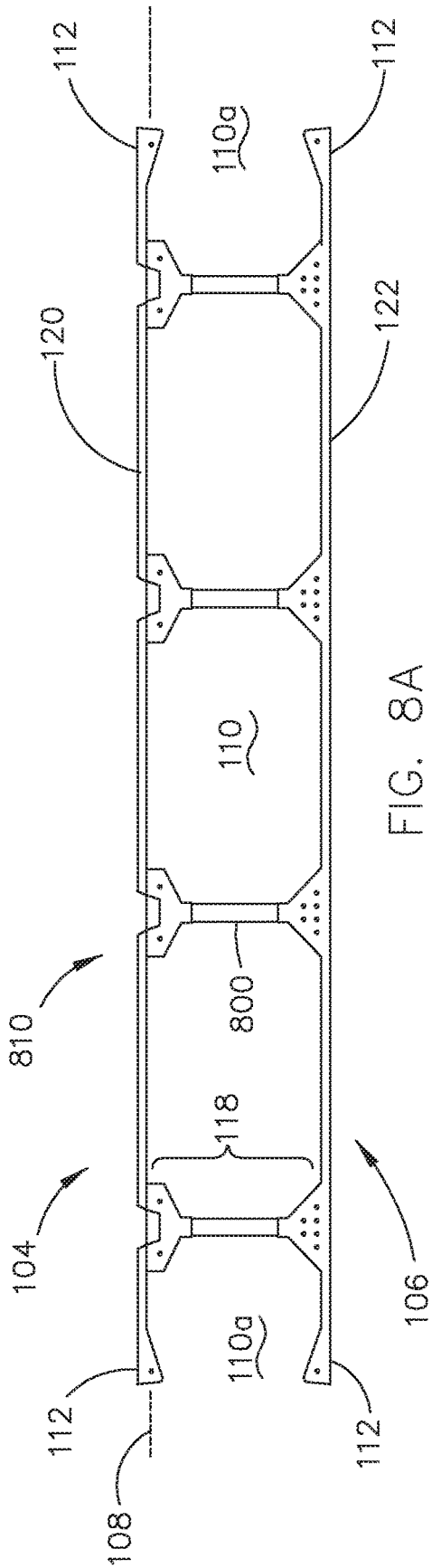

FIG. 7



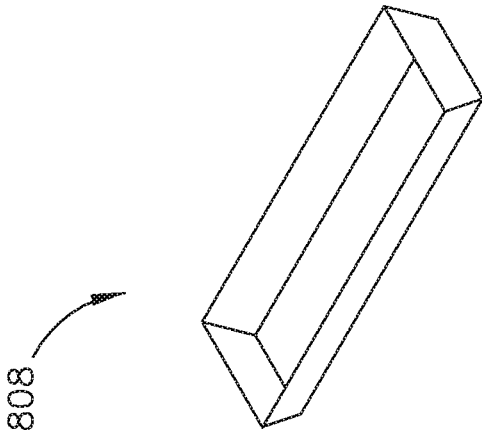

FIG. 8E

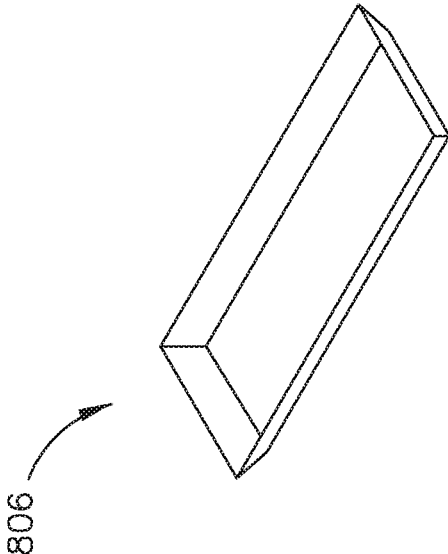

FIG. 8D

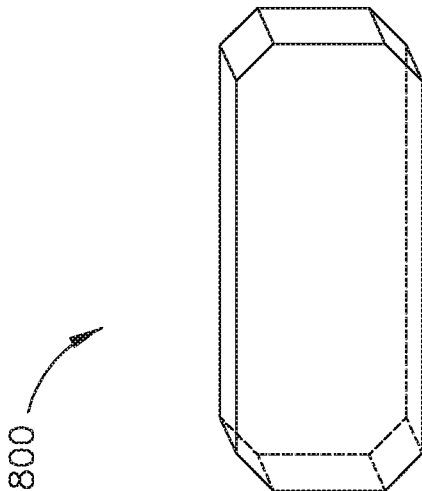
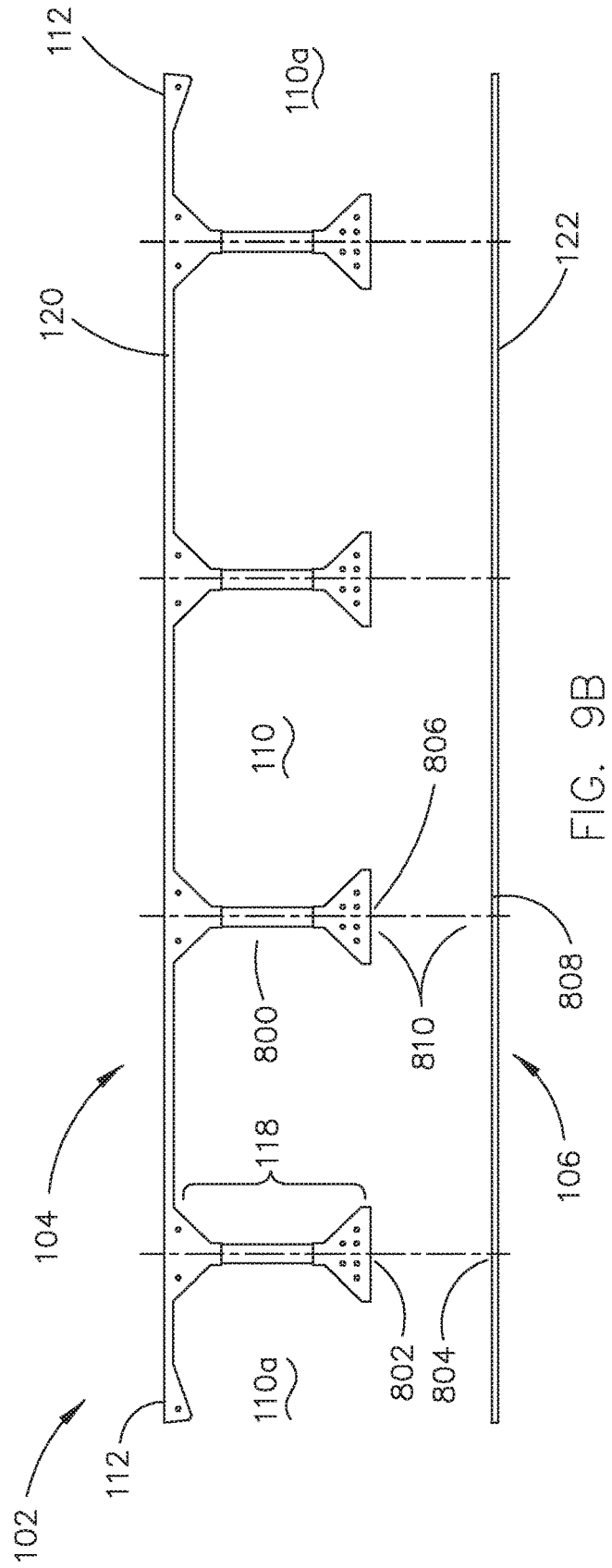
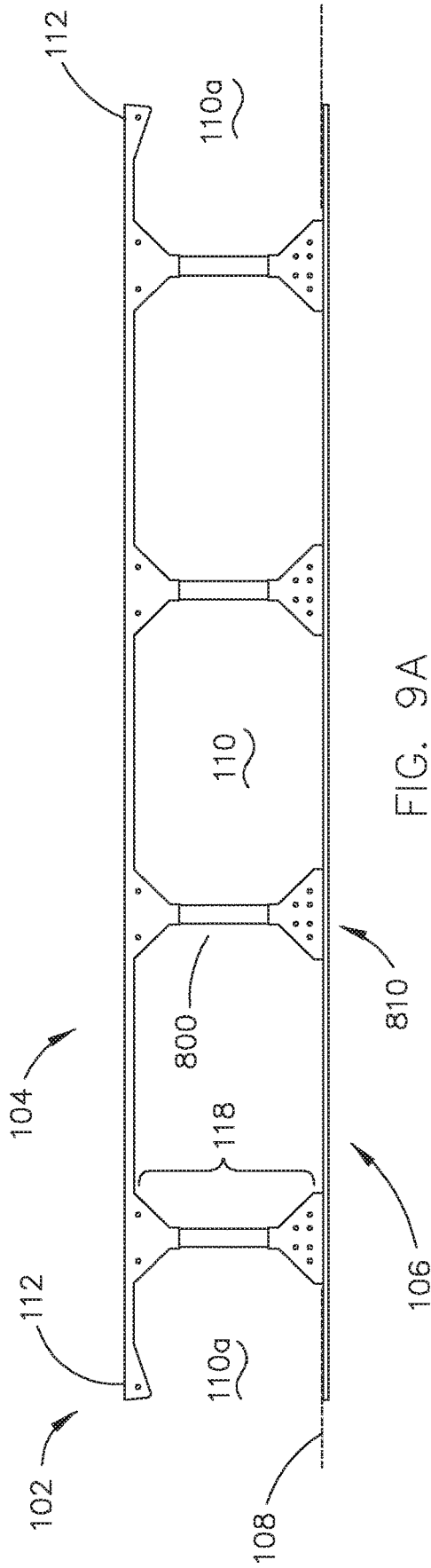

FIG. 8C



800

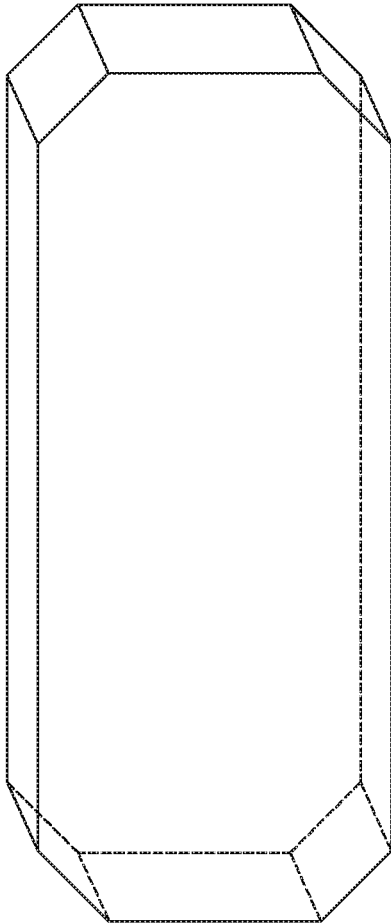

FIG. 9C

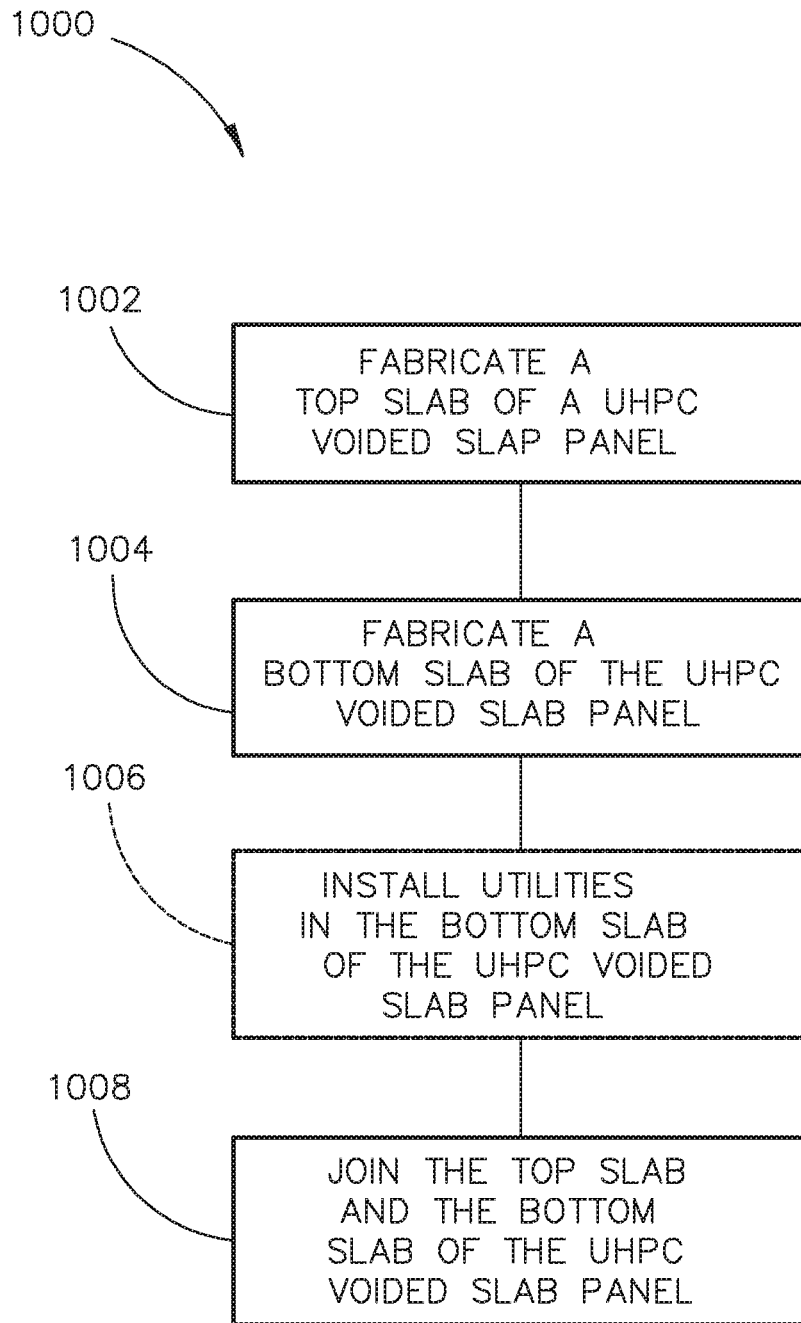

FIG. 10

ULTRA HIGH PERFORMANCE CONCRETE VOIDED SLAB PANELS

CROSS-REFERENCE TO RELATED APPLICATIONS

The present application claims the benefit under 35 U.S.C. § 119(e) of U.S. Provisional Patent Application Ser. No. 62/810,568, filed Feb. 26, 2019, titled ULTRA HIGH PERFORMANCE CONCRETE VOIDED SLAB SYSTEM, naming Maher K. Tadros, Micheal Asaad, and Bradley L. Schipper as inventors, which is incorporated herein by reference in the entirety.

TECHNICAL FIELD

The present invention generally relates to the field of concrete panels and, more particularly, to ultra high performance concrete voided slab panels.

BACKGROUND

Select residential and commercial structures are supported, at least in part, by parking structures positioned underneath the floors reserved for living, office, retail, and/or storage. Due to spacing constraints caused by accommodating vehicle operation and parking within the parking structure, the parking structure may be constructed from slabs. For example, parking structures may include slabs with a sixty-foot span, which includes two eighteen-foot parking areas and a twenty-four-foot, two-way aisle. For instance, slab systems that do not allow for a clear span of sixty feet include intermediate columns that are obstructions and a safety hazard to the individuals wishing the park their vehicles. In addition, slab systems that would allow for a clear span of sixty feet without intermediate columns require a structural floor depth much greater than the depth allowed for such floor. These slabs may be supported by walls or large columns which may be spaced further apart than the load-bearing walls of the above floors, such that the load-bearing walls of the above floors are denser, or more closely spaced. This, in turn, may cause conflicts in the building plans for the select residential and commercial structures.

SUMMARY

An ultra high performance concrete (UHPC) voided slab panel is disclosed, in accordance with one or more embodiments of the disclosure. The panel may include a top slab including a top skin and a bottom slab including a bottom skin. The top slab and the bottom slab may be joined at a joint positioned a select height within the UHPC voided slab panel. The joint may be filled with a joint material during the joining of the top slab and the bottom slab. The top slab and the bottom slab may be joined via a connector assembly. The panel may include at least two ribs. The at least two ribs may define at least one void. The at least one void may be accessible via at least one opening through an exterior surface of the UHPC voided slab panel. The UHPC voided slab panel may be fabricated from UHPC and a plurality of embedded prestressing strands. The UHPC voided slab panel may be configured to meet select strength requirements that are greater than select strength requirements for conventional precast concrete without reinforcing bars being embedded within the UHPC voided slab panel.

In some embodiments, the at least one void may be configured to house one or more utility components, the one

or more utility components being configured to transfer one or more utilities through the UHPC voided slab panel.

In some embodiments, the at least one void may be accessible via at least one opening within an exterior span surface of the UHPC voided slab panel or via at least one opening within an exterior width surface of the UHPC voided slab panel.

In some embodiments, the at least one void may include a first void accessible via at least one opening within a span surface of a span of the UHPC voided slab panel and a second void accessible via at least one opening within a width surface of the UHPC voided slab panel.

In some embodiments, the select height being at mid-depth of the UHPC voided slab panel, a first portion of each of the at least two ribs being formed with the top slab and a corresponding second portion of each of the at least two ribs being formed with the bottom slab.

In some embodiments, the first portion of each of the at least two ribs and the corresponding second portion of each of the at least two ribs may be coupled together via the connector assembly. The connector assembly may include a keyed assembly with a male keyed structure and a female keyed structure. The male keyed structure may be configured to interlock with the female keyed structure. The male keyed structure may be configured to pass through a plane when interlocking with the female keyed structure. The plane may be at mid-depth of the UHPC voided slab panel.

In some embodiments, a first portion of a first rib of the at least two ribs may include a male keyed structure and a corresponding second portion of the first rib of the at least two ribs may include a corresponding female keyed structure. A first portion of a second rib of the at least two ribs including a female keyed structure and a corresponding second portion of the second rib of the at least two ribs may include a corresponding male keyed structure.

In some embodiments, the select height may be proximate to the top slab of the UHPC voided slab panel.

In some embodiments, the at least two ribs may be formed with the bottom slab.

In some embodiments, the top slab may include a first component of the connector assembly. The at least two ribs may be formed with the bottom slab including a second component of the connector assembly.

In some embodiments, the select height may be proximate to the bottom slab of the UHPC voided slab panel.

In some embodiments, the at least two ribs may be formed with the top slab.

In some embodiments, the bottom slab may include a first component of the connector assembly. The at least two ribs formed with the top slab may include a second component of the connector assembly.

In some embodiments, the connector assembly may include at least one rod in the bottom slab and at least one hole in the top slab. The at least one hole may be configured to receive the at least one rod when the top slab and the bottom slab are joined.

In some embodiments, the at least one rod may be configured to be inserted within the at least two ribs.

An ultra high performance concrete voided slab system is disclosed, in accordance with one or more embodiments of the disclosure. The system may include a plurality of ultra high performance concrete (UHPC) voided slab panels. Each UHPC voided slab panel of the plurality of UHPC voided slab panels may include a top slab including a top skin and a bottom slab including a bottom skin. The top slab and the bottom slab may be joined at a joint positioned a select height within the UHPC voided slab panel. The joint

may be filled with a joint material during the joining of the top slab and the bottom slab. The top slab and the bottom slab may be joined via a connector assembly. Each UHPC voided slab panel of the plurality of UHPC voided slab panels may include least two ribs. The at least two ribs may define at least one void. The at least one void may be accessible via at least one opening within an exterior surface of the UHPC voided slab panel. The UHPC voided slab panel may be fabricated from UHPC and a plurality of embedded prestressing strands. The UHPC voided slab panel may be configured to meet select strength requirements that are greater than select strength requirements for conventional precast concrete without reinforcing bars being embedded within the UHPC voided slab panel.

In some embodiments, each UHPC voided slab panel of the plurality of UHPC voided slab panels may include a span edge on at least one of the top slab or the bottom slab. Adjacent UHPC voided slab panels of the plurality of UHPC voided slab panels may be couplable together via adjacent span edges of the adjacent UHPC voided slab panels.

A method is disclosed, in accordance with one or more embodiments of the present disclosure. The method may include, but is not limited to, fabricating a top slab of an ultra high performance concrete (UHPC) voided slab panel with a top formwork. Fabricating the top slab may include pouring a first amount of UHPC within at least two rib portions to fabricate at least two ribs. The space between the at least two ribs may define at least one void. Fabricating the top slab may include pouring a second amount of UHPC within at least one skin portion to fabricate a top skin. The top formwork may include a plurality of prestressing strands positioned to be embedded during the pouring of the at least one of the first amount of UHPC or during the pouring of the second amount of UHPC. The method may include, but is not limited to, fabricating a bottom slab of the UHPC voided slab panel with a bottom formwork. The fabricating the bottom slab may include pouring a first amount of UHPC within at least two ribs portion to fabricate at least two ribs. The space between the at least two ribs may define at least one void. The fabricating the bottom slab may include pouring a second amount of UHPC within at least one skin portion to fabricate a bottom skin. The bottom formwork may include a plurality of prestressing strands positioned to be embedded during the pouring of the at least one of the first amount of UHPC or during the pouring of the second amount of UHPC. The method may include, but is not limited to, joining the top slab of the UHPC voided slab panel and the bottom slab of the UHPC voided slab panel together via a connector assembly. The joint may be filled with a joint material during the joining of the top slab and the bottom slab. The UHPC voided slab panel may be configured to meet select strength requirements that are greater than select strength requirements for conventional precast concrete without reinforcing bars being embedded within the UHPC voided slab panel.

In some embodiments, the method may include, but is not limited to, installing one or more utility components within the at least one void. The one or more utility components may be configured to transfer one or more utilities through the UHPC voided slab panel.

In some embodiments, the top formwork and the bottom formwork may be a single formwork. The top slab may be fabricated before the bottom slab. The fabricated top slab may be removed from the single formwork prior to the fabricating of the bottom slab.

This Summary is provided solely as an introduction to subject matter that is fully described in the Detailed Descrip-

tion and Drawings. The Summary should not be considered to describe essential features nor be used to determine the scope of the Claims. Moreover, it is to be understood that both the foregoing Summary and the following Detailed Description are examples and explanatory only and are not necessarily restrictive of the subject matter claimed.

BRIEF DESCRIPTION OF THE DRAWINGS

The numerous advantages of the disclosure may be better understood by those skilled in the art by reference to the accompanying figures in which:

FIG. 1A illustrates a perspective view of an ultra high performance concrete (UHPC) voided slab system including a set of ultra high performance concrete (UHPC) voided slab panels, in accordance with one or more embodiments of the disclosure;

FIG. 1B illustrates a perspective view of a top slab of an ultra high performance concrete (UHPC) voided slab panel, in accordance with one or more embodiments of the disclosure;

FIG. 1C illustrates a perspective view of a bottom slab of an ultra high performance concrete (UHPC) voided slab panel, in accordance with one or more embodiments of the disclosure;

FIG. 2A illustrates an elevation view of a solid ribbed portion of a formwork for a top slab or a bottom slab of an ultra high performance concrete (UHPC) voided slab panel, in accordance with one or more embodiments of the disclosure;

FIG. 2B illustrates an elevation view of a voided ribbed portion of a formwork for a top slab or a bottom slab of an ultra high performance concrete (UHPC) voided slab panel, in accordance with one or more embodiments of the disclosure;

FIG. 3A illustrates a perspective view of a set of blockouts for a top slab and a bottom slab of an ultra high performance concrete (UHPC) voided slab panel, in accordance with one or more embodiments of the disclosure;

FIG. 3B illustrates a perspective view of a set of sleeves for a top slab and a bottom slab of an ultra high performance concrete (UHPC) voided slab panel, in accordance with one or more embodiments of the disclosure;

FIG. 4A illustrates a partial exploded view of an ultra high performance concrete (UHPC) voided slab panel, in accordance with one or more embodiments of the disclosure;

FIG. 4B illustrates a partial exploded view of an ultra high performance concrete (UHPC) voided slab panel, in accordance with one or more embodiments of the disclosure;

FIG. 4C illustrates a perspective view of a keyed structure of an ultra high performance concrete (UHPC) voided slab panel, in accordance with one or more embodiments of the disclosure;

FIG. 4D illustrates a perspective view of a keyed structure of an ultra high performance concrete (UHPC) voided slab panel, in accordance with one or more embodiments of the disclosure;

FIG. 5 illustrates a partial elevation view of an ultra high performance concrete (UHPC) voided slab panel, in accordance with one or more embodiments of the disclosure;

FIG. 6 illustrates an elevation view of an ultra high performance concrete (UHPC) voided slab panel, in accordance with one or more embodiments of the disclosure;

FIG. 7 illustrates an elevation view of an ultra high performance concrete (UHPC) voided slab panel, in accordance with one or more embodiments of the disclosure;

5

FIG. 8A illustrates an elevation view of an ultra high performance concrete (UHPC) voided slab panel, in accordance with one or more embodiments of the disclosure;

FIG. 8B illustrates an exploded elevation view of an ultra high performance concrete (UHPC) voided slab panel, in accordance with one or more embodiments of the disclosure;

FIG. 8C illustrates a perspective view of a keyed structure of an ultra high performance concrete (UHPC) voided slab panel, in accordance with one or more embodiments of the disclosure;

FIG. 8D illustrates a perspective view of a keyed structure of an ultra high performance concrete (UHPC) voided slab panel, in accordance with one or more embodiments of the disclosure;

FIG. 8E illustrates a perspective view of a cut-out of an ultra high performance concrete (UHPC) voided slab panel, in accordance with one or more embodiments of the disclosure;

FIG. 9A illustrates an elevation view of an ultra high performance concrete (UHPC) voided slab panel, in accordance with one or more embodiments of the disclosure;

FIG. 9B illustrates an exploded elevation view of an ultra high performance concrete (UHPC) voided slab panel, in accordance with one or more embodiments of the disclosure;

FIG. 9C illustrates a perspective view of a cut-out of an ultra high performance concrete (UHPC) voided slab panel, in accordance with one or more embodiments of the disclosure; and

FIG. 10 illustrates a method for fabricating an ultra high performance concrete (UHPC) voided slab panel, in accordance with one or more embodiments of the disclosure.

DETAILED DESCRIPTION OF THE INVENTION

Reference will now be made in detail to the subject matter disclosed, which is illustrated in the accompanying drawings.

Referring in general to FIGS. 1A-10, ultra high performance concrete voided slab panels are described, in accordance with one or more embodiments of the disclosure.

Embodiments of the disclosure are directed to an ultra high performance concrete (UHPC) voided slab system including one or more ultra high performance concrete (UHPC) voided slab panels, where a voided slab panel includes a top slab and a bottom slab, where one or more voids are formed between the top slab and the bottom slab. Embodiments of the disclosure are also directed to prestressing strands (or cables) embedded longitudinally in the top slab and/or the bottom slab to ensure adequate flexural (e.g., bending) capacity of the UHPC voided slab system. Embodiments of the disclosure are also directed to using steel fibers instead of rebar and/or shearing reinforcements, resulting in a system that is easier to manufacture and is thinner than conventional concrete slabs.

The ultra high performance concrete (UHPC) as described and used in the disclosure may be fabricated by mixing steel fibers including a powder mixture including silica fume. For example, the steel fibers may be approximately 0.2 millimeters (mm) in diameter, and may range from twelve to twenty millimeters in length. The steel fibers and the powder mixture may be mixed so as to ensure a desired level of consistency/uniformity within the UHPC. The steel fibers and the powder mixture may be mixed so as to ensure a random orientation of the steel fibers within the UHPC.

The steel fibers may make up a select percentage of the total volume of the UHPC as described and used in the

6

disclosure. For example, the steel fibers may be approximately two percent by total volume. It is noted herein, however, that the formula for determining the correct percentage of steel fibers with respect to total volume may be dependent on a select loading density and/or a select span capacity of the UHPC voided slab panels of the UHPC voided slab system.

The UHPC as described and used in the disclosure may have select strength requirements that are superior to the select requirements of conventional precast concrete. For example, the compressive strength of the UHPC may be approximately 18,000 pounds per square inch (psi), versus 5,000 psi for conventional concrete. By way of another example, the tensile strength of the UHPC may be approximately 2,500 psi, versus 500 psi for conventional concrete. It is noted herein that the increased strength requirements may allow for the UHPC voided slab system to have UHPC voided slab panels with a clear sixty-foot span in all floors above a parking structure. In addition, it is noted herein that UHPC is a term coined by the Federal Highway Administration, which has separate requirements for compressive strength (e.g., 21,300 psi) and tensile strength (e.g., 720 psi) than that of the UHPC as described and used in the disclosure.

Select conventional precast concrete slabs may utilize one or more of rebar and/or shearing reinforcements to meet or exceed desired strength requirements. In contrast to those select conventional precast concrete slabs, voided slabs generated from the UHPC as described and used in the disclosure may not utilize any additional support components (e.g., reinforcing bars, or the like) beyond the steel fibers combined with the powder mixture and any prestressing stands embedded longitudinally in the voided slabs. In this regard, voided slabs fabricated from the UHPC as used and described in the disclosure may be lighter, may be of a thinner thickness, and/or may require less material quantities than the select conventional precast concrete slabs, resulting in a stronger concrete slab that is easier to manufacture and transport than the select conventional precast concrete slabs.

FIGS. 1A-1C generally illustrate perspective views of one or more ultra high performance concrete (UHPC) voided slab panels **102** of an ultra high performance concrete (UHPC) voided slab system **100**, in accordance with one or more embodiments of the disclosure. The UHPC voided slab panel **102** may be fabricated from a top slab **104** (e.g., as illustrated in FIG. 1B) and a bottom slab **106** (e.g., as illustrated in FIG. 1C), where the top slab **104** and the bottom slab **106** are joined or coupled together at a joint **108**. In one example, the UHPC voided slab panel **102** as illustrated in FIGS. 1A-1C may measure in at 60 feet in length/span by 12 feet in width by 22 inches in height/thickness. It is noted herein, however, that the UHPC voided slab panel **102** is not limited to the provided dimensions, but may instead be a set of any dimensions. Therefore, the above description should not be interpreted as a limitation on the scope of the disclosure but merely an illustration.

The UHPC voided slab panel **102** may have one or more voids or pockets **110** accessible via one or more openings **116** through an exterior surface of the UHPC voided slab panel **102**. The one or more voids or pockets **110** may allow for utilities to be installed within the UHPC voided slab panel **102** (e.g., installed within the floor above a parking structure, where the UHPC voided slab panel **102** forms a ceiling surface of the parking structure).

The UHPC voided slab panel **102** may include any number of voids **110** (e.g., 1, 2, up to an N number of voids **110**) that pass longitudinally through the span of the UHPC

voided slab panel **102**, where the voids **110** may be separated by one or more ribs **118**. For example, the span of the UHPC voided slab panel **102** may include three voids **110**. For instance, the three voids **110** may be spaced at 3 feet (e.g., the ribs **118** are spaced 3 feet apart from center), such that the outer ribs **118** are 18 inches from the edge of the UHPC voided slab panel **102**. The number of voids **110** through the span of the UHPC voided slab panel **102** and the width of the ribs **118** through the span of the UHPC voided slab panel **102** may be inter-related. For example, the voids **110** through the span of the UHPC voided slab panel **102** may be wider where the ribs **118** between the voids **110** are wider. It is noted herein that this may allow for a thinner skin of the UHPC voided slab panel **102** (e.g., a top skin **120** of the top slab **104** of the UHPC voided slab panel **102** and/or a bottom skin **122** of the bottom slab **106** of the UHPC voided slab panel **102**).

It is noted herein that the UHPC voided slab panel **102** may include a void portion **110a** at each of its two span edges **112**. In this regard, UHPC voided slab panels **102** with adjacent span edges **112** may generate and share a full void **110** via the combining of the respective void portions **110a**. For example, two adjacent UHPC voided slab panels **102** may have a combined seven voids **110** across a combined width. It is noted herein that the UHPC voided slab system **100** may include adjacent UHPC voided slab panels **102** spaced ½-inch apart when installed in residential and commercial structures.

The UHPC voided slab panel **102** may have one or more voids or pockets **114** accessible via one or more openings **116** through an exterior surface of the UHPC voided slab panel **102**. The one or more voids or pockets **114** may allow for utilities to be installed within the UHPC voided slab panel **102** (e.g., installed within the floor above a parking structure, where the UHPC voided slab panel **102** forms a ceiling surface of the parking structure).

The UHPC voided slab panel **102** may include any number of voids **114** (e.g., 1, 2, up to an N number of voids **114**) through the width of the UHPC voided slab panel **102**, such that the ribs **118** through the span of the UHPC voided slab panel **102** are segmented into rib sections **118a**. For example, the span of the UHPC voided slab panel **102** may include eight voids **114**. For instance, the eight voids **114** may be spaced at four feet (e.g., the rib sections **118a** are spaced 4 feet apart from center), while the voids **114** themselves may be 2 feet long. The number of voids **114** through the width of the UHPC voided slab panel **102** and the length of the rib sections **118a** through the width of the UHPC voided slab panel **102** may be inter-related. For example, the voids **114** through the width of the UHPC voided slab panel **102** may be longer where the rib sections **118a** between the voids **114** are longer. It is noted herein that this may allow for a thinner thickness of skin of the UHPC voided slab panel **102** (e.g., the top skin **120** of the top slab **104** of the UHPC voided slab panel **102** and/or the bottom skin **122** of the bottom slab **106** of the UHPC voided slab panel **102**).

It is noted herein that a select distance from each end of the UHPC voided slab panel **102** may not include any voids **114** through the width of the UHPC voided slab panel **102** in order to preserve a select amount of shearing performance (e.g., the UHPC voided slab panel **102** may include a solid ribbed portion and a voided ribbed portion). For example, where the span of the UHPC voided slab panel **102** is sixty feet, the first and last twelve feet of the UHPC voided slab panel **102** may not include any voids **114** through the width of the UHPC voided slab panel **102**. In addition, where the

span of the UHPC voided slab panel **102** is 48 feet, the first 8 feet and the last 8 feet may not include any voids **114** through the width of the UHPC voided slab panel **102**. In general, the first and last twenty percent of the UHPC voided slab panel **102** may not include any voids **114** through the width of the UHPC voided slab panel **102**.

It is noted herein that the UHPC voided slab panel **102** may not be limited to the three voids **110** through the span of the UHPC voided slab panel **102** and/or the eight voids **114** through the width of the UHPC voided slab panel **102**, as illustrated in FIGS. 1A-1C. Therefore, the above description should not be interpreted as a limitation on the scope of the disclosure but merely an illustration.

FIGS. 2A-9C generally illustrate a novel and highly efficient method or process for manufacturing the UHPC voided slab panel **102**, in accordance with one or more embodiments of the disclosure.

FIGS. 2A and 2B illustrate portions of a formwork **200**, in accordance with one or more embodiments of the disclosure. The formwork **200** may be used to form the top slab **104** or the bottom slab **106**. The formwork **200** may be laid on the ground or manufacturing floor. The formwork **200** may rest on a flat steel pallet. The formwork **200** may include a lifting hook to re-position the formwork **200** (e.g., on the ground or manufacturing floor). The formwork **200** may be fabricated from a ⅜-inch steel plate skin. The formwork **200** may include a ¼-inch steel stiffener with a four-foot spacing across the twelve-foot width, with voids **110** being formed between the ¼-inch steel stiffeners. A steel yoke at a four-foot spacing may rest on top of (e.g., either loosely or be coupled to) the formwork **200**.

As illustrated in FIG. 2A, the formwork **200** may include one or more solid ribbed portions **202**. For example, the one or more solid ribbed portions **202** may be configured to create the one or more voids **110**.

As illustrated in FIG. 2B, the formwork **200** may include one or more voided ribbed portions **204**. For example, the one or more voided ribbed portions **204** may be configured to create the one or more voids **110** and the one or more voids **114**.

As illustrated in FIGS. 2A and 2B, the formwork **200** may include a skin portion **206** configured to form the top skin **120** and/or the bottom skin **122**. By way of another example, the formwork **200** may include a rib portion **208** configured to form the one or more ribs **118**. It is noted herein the one or more voids **110**, **114** may be formed between the one or more ribs **118** by the absence of the UHPC in select areas defined by the formwork **200**.

The sides of the rib portion **208** may be tapered to allow for removal of the top slab **104** and/or the bottom slab **106** from the formwork **200**, following the placing of the UHPC. For example, the sides of the rib portion **208** may be dimensioned such that the top of the ribs **118** (e.g., the portion near the top skin **120** of the top slab **104** and/or the portion near the bottom skin **122** of the bottom slab **106**) may be 26 inches in length, while the bottom of the ribs **118** (e.g., the portion near the mid-depth of the UHPC voided slab panel **102**) may be 24 inches in length. By way of another example, the sides of the rib portion **208** may be dimensioned such that the top of the voids **110**, **114** (e.g., the top skin **120** of the top slab **104** and/or the portion near the bottom skin **122** of the bottom slab **106**) may be 22 inches in length, while the bottom of the voids **110**, **114** (e.g., the portion near the mid-depth of the UHPC voided slab panel **102**) may be 24 inches in length.

The formwork **200** may include a ⅜-inch by 3-inch horizontal stiffener flanking each side of each void between

the ¼-inch steel stiffeners. The formwork **200** may include a 1-inch by 3-inch continuous shim along each side. The formwork **200** may include a 6-inch by 1-inch plastic plywood board, where the plastic plywood may be continuous down the middle. The plastic plywood board may include a ½-inch deep shear key cut. For instance, the shear key cut may be set at a 6-inch spacing.

It is noted herein that the formwork **200** illustrated in FIGS. **2A** and **2B** is only an example, and that the formwork **200** may be fabricated with cut-outs and/or dimensions that differ from those illustrated in FIGS. **2A** and **2B**. As such, the formwork **200** is not limited to the example as illustrated in FIGS. **2A** and **2B**. Therefore, the above description should not be interpreted as a limitation on the scope of the disclosure but merely an illustration.

Prestressing strands (or cables) may be laid within the formwork **200** and tensioned by being connected to an exterior mount outside of the formwork **200**. For example, each rib of the top slab **104** and/or the bottom slab **106** may have two tensioned prestressing strands (or pre-tensioned, if the point of reference is the placing of UHPC in the formwork), and each span edge **112** and top skin **120** of the top slab **104** or each span edge **112** and bottom skin **122** of the bottom slab **106** may have one tensioned prestressing strand. It is noted herein, however, that the top slab **104** and/or the bottom slab **106** may include any number of tensioned prestressing strands within each rib **118**, span edge **112**, top skin **120**, and/or bottom skin **122**. Therefore, the above description should not be interpreted as a limitation on the scope of the disclosure but merely an illustration.

In the solid ribbed portion **202**, one or more sleeves or blockouts **210** may be inserted through a top surface of the formwork **200**. For example, the one or more sleeves or blockouts **210** may be fabricated from a foam, a plastic (e.g., polyurethane, or the like) or a metal (e.g., sheet metal, or the like). For instance, the sleeves or blockouts **210** may be removed following the placing and setting of the UHPC. By way of another example, the sleeves or blockouts **210** may remain within the slab **104** and/or the slab **106** following the placing and setting of the UHPC.

FIGS. **3A** and **3B** illustrate example embodiments of two types of sleeves or blockouts **210**, in accordance with one or more embodiments of the disclosure.

As illustrated in FIG. **3A**, the one or more sleeves or blockouts **210** may include a top blockout **210a** and a bottom blockout **210b**. The top blockout **210a** and/or the bottom blockout **210b** may be tapered, such that the dimension of the mid-depth opening is smaller than the dimensions of the top skin **120** and/or the bottom skin **122** opening. For example, the opening proximate to the top skin **120** and/or the bottom skin **122** may be 6 inches long by 2 inches wide, while the opening proximate to the mid-depth of the UHPC voided slab panel **102** may be 5 inches long by 1.5 inches wide. By way of another example, the thickness of the blockout **210a** may be 11.5 inches (e.g., for a male keyed structure, described in detail further herein), while the thickness of the blockout **210b** may be 10.375 inches (e.g., for a female keyed structure, described in detail further herein). In this regard, a hole generated by the blockout **210a**, **210b** may be tapered. It is noted herein the blockouts **210a**, **210b** may be removed from the top slab **104** and/or the bottom slab **106** following the placing and setting of the UHPC.

As illustrated in FIG. **3B**, the one or more sleeves or blockouts **210** may include a top sleeve **210a** and a bottom sleeve **210b**. The top sleeve **210a** and/or the bottom sleeve **210b** may be corrugated. For example, the corrugations may

be 3.5 inches long by 1.5 inches wide. By way of another example, the opening in the top skin **120** and/or the bottom skin **122**, as well as the mid-depth of the UHPC voided slab panel **102**, may be similar in dimension and smaller than the corrugations. By way of another example, the thickness of the sleeve **210a** may be 11.5 inches (e.g., for the male keyed structure, described in detail further herein), while the thickness of the sleeve **210b** may be 10.375 inches (e.g., for the female keyed structure, described in detail further herein). It is noted herein the sleeve **210a**, **210b** may be left in the top slab **104** and/or the bottom slab **106** following the placing and setting of the UHPC.

It is noted herein that the sleeves or blockouts **210a**, **210b** as illustrated in FIGS. **3A** and **3B** are only examples, and that the sleeves or blockouts **210a**, **210b** may be fabricated with dimensions that differ from those illustrated in FIGS. **3A** and **3B**. As such, the sleeves or blockouts **210a**, **210b** are not limited to the examples as illustrated in FIGS. **3A** and **3B**. Therefore, the above description should not be interpreted as a limitation on the scope of the disclosure but merely an illustration.

With the sleeves **210** in place, UHPC may be placed within the formwork **200**. For example, the UHPC may be placed within the formwork **200** between the ¼-inch steel stiffeners to form the one or more ribs **118**. It is noted herein that care may need to be taken to not get UHPC in the hollow sleeves **210** (e.g., within the solid ribbed portion **202** of the formwork **200**). The sides of the rib portion **208** may be tapered to allow for removal of the top slab **104** and/or the bottom slab **106** from the formwork **200** once the UHPC is at least partially set. Each span edge **112** of the top slab **104** and/or the bottom slab **106** may be thicker than the remainder of the top skin **120** of the top slab **104** and/or the bottom skin **122** of the bottom slab **106** to allow space for connecting adjacent UHPC voided slab panels **102** (e.g., as illustrated in FIG. **1A**).

After the one or more ribs **118** are formed from the placed UHPC, the top skin **120** of the top slab **104** and/or the bottom skin **122** of the bottom slab **106** may be formed from UHPC. For example, the top skin **120** of the top slab **104** and/or the bottom skin **122** of the bottom slab **106** may be approximately one inch in thickness. By way of another example (e.g., as illustrated by the formwork **200** in FIGS. **2A** and **2B**), the top skin **120** of the top slab **104** and/or the bottom skin **122** of the bottom slab **106** may have additional material at each span edge **112** with a quantity that is greater than approximately one inch in thickness. For instance, the quantity of additional material at each span edge **112** may increase from one inch to three inches over a six-inch run.

It is noted herein, however, that the one or more ribs **118** and the top skin **120** or bottom skin **122** may be formed simultaneously or substantially simultaneously. Therefore, the above description should not be interpreted as a limitation on the scope of the disclosure but merely an illustration.

The UHPC may be allowed to set, or at least cure to a select hardness (e.g., a not fully set state) that is still capable of transportation. Once the amount of curing has reached the select threshold, the prestressing strands may be cut to de-tension the top slab **104** and/or the bottom slab **106**. The top slab **104** and/or the bottom slab **106** may be removed from the formwork **200**, and can be stored until it is joined with a corresponding bottom slab **106** and/or top slab **104**.

In the case of the bottom slab **106**, it is noted herein the prestressing strands may not be cut until after the joining of the top slab **104**. Therefore, the above description should not be interpreted as a limitation on the scope of the disclosure but merely an illustration.

FIGS. 4A-4D and 5 generally illustrate the UHPC voided slab panel 102, in accordance with one or more embodiments of the disclosure.

One or more keyed structures may be formed on the one or more ribs 118. The top slab 104 and/or the bottom slab 106 may include one or more male keyed structures 400 extruding from one or more surfaces 404 and/or one or more female keyed structures 402 cut into one or more surfaces 406. It is noted herein a male keyed structure 400 and a female keyed structure 402 may be considered components of a keyed assembly 408. It is noted herein the keyed assembly 408 may be considered a connector assembly, for purposes of the disclosure.

In general, the one or more male keyed structures 400 and the one or more female keyed structures 402 may include any respective cross-section configured to at least partially interlock.

For example, the one or more male keyed structures 400 may include a trapezoidal cross-section. The one or more male keyed structures 400 may be tapered, such that the dimensions at mid-depth of the UHPC voided slab panel 102 are smaller than the dimensions at a select distance from the mid-depth. For example, the dimensions at mid-depth of the UHPC voided slab panel 102 may be 11 inches by 1.5 inches, while the dimensions at the select distance from mid-depth may be 11.5 inches by 1.75 inches, where the select distance is 0.5 inches.

By way of another example, the one or more female keyed structures 402 may include a trapezoidal cross-section. The one or more female keyed structures 402 may be tapered, such that the dimensions at mid-depth of the UHPC voided slab panel 102 are larger than the dimensions at a select distance from the mid-depth. For example, the dimensions at mid-depth of the UHPC voided slab panel 102 may be 12 inches by 1.875 inches, while the dimensions at the select distance from mid-depth may be 11.5 inches by 1.625 inches, where the select distance is 0.625 inches.

It is noted herein that the male keyed structure 400 and the female keyed structure 402 as illustrated in FIGS. 4C and 4D are only examples, and that the male keyed structure 400 and the female keyed structure 402 may be fabricated with dimensions that differ from those illustrated in FIGS. 4C and 4D. As such, the male keyed structure 400 and the female keyed structure 402 are not limited to the examples as illustrated in FIGS. 4C and 4D. Therefore, the above description should not be interpreted as a limitation on the scope of the disclosure but merely an illustration.

Where the top slab 104 and the bottom slab 106 each include one or more male keyed structures 400 and one or more female keyed structures 402, the one or more male keyed structures 400 and the one or more female keyed structures 402 may be alternated within the one or more ribs 118. It is noted herein that alternating the one or more male keyed structures 400 and the one or more female keyed structures 402 may allow for the use of the single formwork 200 to manufacture both the top slab 104 and the bottom slab 106.

Although embodiments illustrate the top slab 104 and the bottom slab 106 including keyed structures 400, 402 configured to interlock when coupled together, it is noted herein the keyed structures 400, 402 are set within the one or more ribs 118 such that the joint 108 is a straight line at a same mid-depth height throughout (e.g., across the width and along the length/span) the UHPC voided slab panel 102. For example, the male keyed structures 400 may be configured to pass through a plane defined by the joint 108 and the surfaces 406, 408 when the top slab 104 and the bottom slab

106 are coupled together to interlock with corresponding female keyed structures 402, such that the plane is not altered by the points of interlocking and instead is the same mid-depth height throughout the UHPC voided slab panel 102. Therefore, the above description should not be interpreted as a limitation on the scope of the disclosure but merely an illustration.

Where a rib 118 includes a male keyed structure 400, the rib 118 may be 10.5 inches in total thickness and 10 inches in width. For example, the rib 118 (or a rib section 118a) may include a 0.5-inch thick male key structure 400 extended 0.5 inches into mid-depth, may change from 2.5 inches wide at mid-depth to 3 inches wide along a height of 5 inches from mid-depth, may have a section that is 3 inch wide by 1 inch thick, and may have a section that changes from 3 inches wide at 6 inches from mid-depth to 10 inches wide along a height of 5 inches between 5 inches and 10 inches from mid-depth.

Where a rib 118 includes a female keyed structure 402, the rib 118 may be 10 inches in total thickness and 10 inches in width. For example, the rib 118 (or a rib section 118a) may change from 2.5 inches wide at mid-depth to 3 inches wide along a height of 5 inches from mid-depth with a female keyed structures 402 cut into the rib 118 0.625 inches at mid-depth, may have a section that is 3 inch wide by 1 inch thick, and may have a section that changes from 3 inches wide at 6 inches from mid-depth to 10 inches wide along a height of 5 inches between 5 inches and 10 inches from mid-depth.

It is noted herein the combined thickness of the rib 118 and the top skin 120 may result in the top slab 104 or the bottom slab 106, respectively, to have a combined thickness of 11 inches (not counting the male keyed structures 400). As such, the mid-depth of the UHPC voided slab panel 102 may be positioned at a height of 11 inches.

It is noted herein that the one or more ribs 118 as illustrated in FIGS. 4A and 4B is only an example, and that the one or more ribs 118 may be fabricated with dimensions that differ from those illustrated in FIGS. 4A and 4B. As such, the bottom sleeve is not limited to the example as illustrated in FIGS. 4A and 4B. Therefore, the above description should not be interpreted as a limitation on the scope of the disclosure but merely an illustration.

Where the sleeves or blockouts 210 are removed following a setting of the UHPC, the top slab 104 and/or the bottom slab 106 may include one or more holes 410. Where the sleeves or blockouts 210 are left in following a setting of the UHPC, the sleeves or blockouts 210 may be at least partially hollow and include the one or more holes 410.

The one or more holes 410 may be configured to pass through the one or more ribs 118 and subsequently the pass through the one or more male keyed structures 400. The one or more holes 410 may be configured to pass through into the one or more female keyed structures 402 and subsequently pass through the one or more ribs 118.

In one example, as illustrated in FIG. 5, a first section of the UHPC voided slab panel 102 may include a first set of the one or more holes 410 may be spaced 4 feet apart for 16 feet (e.g., a total of four holes 410) from a center of symmetry positioned midspan (e.g., 30 feet along the length/span of the UHPC voided slab panel 102). A second section of the UHPC voided slab panel 102 (e.g., defined from the end of the first section of the UHPC voided slab panel 102) may include a second set of the one or more holes 410 may be spaced 2 feet apart for 12 feet (e.g., meaning a total of six holes 410). A third section of the UHPC voided slab panel 102 (e.g., defined from the end of the second section of the

UHPC voided slab panel **102**) may include the remaining 2 feet of the 30-foot length from midspan.

It is noted herein that the positioning of the holes **410** as illustrated in FIG. **5** is only an example, and that the holes **410** may be positioned differently from those illustrated in FIG. **5**. As such, the UHPC voided slab panel **102** is not limited to the example as illustrated in FIG. **5**. Therefore, the above description should not be interpreted as a limitation on the scope of the disclosure but merely an illustration.

FIG. **6** illustrates the UHPC voided slab panel **102**, in accordance with one or more embodiments of the disclosure.

One or more rods **600** may be secured within the formwork **200**. For example, the one or more rods **600** may be secured with chairs, or the like. By way of another example, the one or more rods **600** may be threaded. The one or more rods **600** may be positioned in the bottom slab **106** (e.g., within the holes **410** in the bottom slab **106**). The one or more rods **600** may be aligned with the holes **410** in the top slab **104**. It is noted herein the rods **600** and the holes **410** (e.g., created by the removable sleeves or blockouts **210** or within the sleeves or blockouts **210**) may be considered components of a connector assembly **602**.

Where the bottom sleeves or blockouts **210b** are left in the bottom slab **106**, the bottom sleeves or blockouts **210b** may be attached to each rod **600** at the top of the ribs **118** under each of the expected top sleeves or blockouts **210a** located within the top slab **104**.

Where the sleeves or blockouts **210a**, **210b** are removed from the UHPC voided slab panel **102**, the holes **410** generated by the sleeves or blockouts **210a**, **210b** may be tapered to produce a wedging effect against the one or more rods **600** when the one or more rods **600** are inserted into the holes **410**.

The one or more rods **600** may be a length allowing for a select amount of clearance from a top surface of the top skin **120** of the top slab **104** and/or a bottom surface of the bottom skin **122** of the bottom slab **106**. For example, the clearance may be a 0.5-inch clearance. For instance, where the UHPC voided slab panel **102** is 22 inches thick, the one or more rods **600** may be 21 inches in length. The one or more rods **600** may be 3/4-inch in diameter.

With the rods **600** secured, UHPC may be placed within the formwork **200**. For example, the UHPC may be placed within the formwork **200** between the 1/4-inch steel stiffeners to form the one or more ribs **118**. It is noted herein that care may need to be taken to not get UHPC in the hollow sleeves **210** (e.g., within the solid ribbed portion **202** of the formwork **200**). The sides of the rib portion **208** may be tapered to allow for removal of the top slab **104** and/or the bottom slab **106** from the formwork **200** once the UHPC is at least partially set. Each span edge **112** of the top slab **104** and/or the bottom slab **106** may be thicker than the remainder of the top skin **120** of the top slab **104** and/or the bottom skin **122** of the bottom slab **106** to allow space for connecting adjacent UHPC voided slab panels **102** (e.g., as illustrated in FIG. **1A**).

After the one or more ribs **118** are formed from the placed UHPC, the top skin **120** of the top slab **104** and/or the bottom skin **122** of the bottom slab **106** may be formed. For example, the top skin **120** of the top slab **104** and/or the bottom skin **122** of the bottom slab **106** may be approximately one inch in thickness. By way of another example (e.g., as illustrated by the formwork **200** in FIGS. **2A** and **2B**), the top skin **120** of the top slab **104** and/or the bottom skin **122** of the bottom slab **106** may have additional material at each span edge **112** with a quantity that is greater than approximately one inch in thickness. For instance, the

quantity of additional material at each span edge **112** may increase from one inch to three inches over a six-inch run.

It is noted herein, however, that the one or more ribs **118** and the top skin **120** and/or bottom skin **122** may be formed simultaneously or substantially simultaneously. Therefore, the above description should not be interpreted as a limitation on the scope of the disclosure but merely an illustration.

It is noted herein, however, that the arrangement of the rods **600** as illustrated in FIG. **6** is only an example, and that the arrangement of the rods **600** may differ from that illustrated in FIG. **6**. As such, the arrangement of the rods **600** is not limited to the example as illustrated in FIG. **6**. Therefore, the above description should not be interpreted as a limitation on the scope of the disclosure but merely an illustration.

FIG. **7** illustrates the UHPC voided slab panel **102**, in accordance with one or more embodiments of the disclosure.

The UHPC may be allowed to cure to a select hardness (e.g., a not fully set state) that is capable of holding shape. Once the amount of curing has reached the select threshold, the formwork **200** may be removed from the bottom slab **106**. The sleeves or blockouts **210** may be filled with a quantity of material to secure the rods **600** and to provide a select (e.g., required minimum) interface shearing capacity. For example, the sleeves may be filled with additional UHPC, with a high-strength non-shrink (HSNS) grout, or the like. When the bottom slab **106** has fully set, or at least has a desired amount of connection to the top slab **104**, the prestressing strands may be cut to de-tension the bottom slab **106**. For example, the prestressing strand de-tensioning may require a compressive strength of at least 10,000 psi in the bottom slab **106**, which may take on the order of one to three days.

The top slab **104** may then be lowered onto the bottom slab **106**, such that the rods **600** within the bottom slab **106** may align with the holes **410** in the top slab **104** generated by the sleeves or blockouts **210** (or the holes **410** within the sleeves or blockouts **210**), and the top slab **104** is released. It is noted herein the top slab **104** may be lowered onto the bottom slab **106** prior to or after the de-tensioning of the bottom slab **106**. In addition, it is noted herein the one or more holes **410** may be configured to couple to the one or more rods **600** and/or may be configured to receive components configured to couple to the one or more rods **600**.

During the joining of the top slab **104** onto the bottom slab **106**, an 0.125-inch gap between the top slab **104** onto the bottom slab **106** may be filled with a joining material or joint material **700**. For example, the joint material **700** may include an epoxy, plastic, cement raw material or cement mixed product, UHPC, or other material configured to securely join the top slab **104** and the bottom slab **106**. The joint material **700** may be applied to the surfaces **404**, **406** of the top slab **104** and the bottom slab **106**, respectively.

It is noted herein that utility components (e.g., wires, pipes, ductwork, or the like) configured to transfer water utilities, power utilities, data utilities, heating, venting, and air conditioning (HVAC) utilities, or the like may then be inserted into the voids **110**, **114** defined within the bottom slab **106** prior to the joining of the top slab **104**. While the utilities may not need to be inserted at this stage (e.g., the utilities may be inserted following the joining of the top slab **104** and/or the installation of the UHPC voided slab panel **102** at a job site), but that inserting the utilities into the voids **110**, **114** defined within the bottom slab **106** prior to the joining of the top slab **104** may greatly reduce job time.

Therefore, the above description should not be interpreted as a limitation on the scope of the disclosure but merely an illustration.

The top slab **104** and/or the bottom slab **106** may include one or more locations for lifting inserts to assist in the removal of the top slab **104** and/or the bottom slab **106** from the formwork **200** and/or the full UHPC voided slab panel **102** from the formwork **200** following the lowering of the top slab **104** onto the bottom slab **106** and subsequent setting. For example, a lifting insert may be positioned in the hole **410** (e.g., within the top slab **104** and the bottom slab **106**, within the sleeves or blockouts **210a**, **210b**, or the like) at the midspan and in the hole **410** before the no-void sections of the one or more ribs **118**. For instance, the lifting insert positioned in the hole **410** at the midspan and the lifting insert positioned in the hole **410** before the no-void section of the ribs **118** may be separated by sixteen feet.

Although embodiments of the disclosure are directed to the top slab **104** and the bottom slab **106** being formed from the same formwork **200**, it is noted herein the formwork **200** for the top slab **104** and the formwork **200** for the bottom slab **106** may be different (e.g., where the UHPC voided slab panel **102** is produced in experimental or research conditions). In addition, it is noted herein that the formwork **200** illustrated in FIGS. **2A** and **2B** is only an example, and that the formwork **200** may be fabricated with cut-outs, dimensions, or the like that differ from those illustrated in FIGS. **2A** and **2B**. As such, the formwork **200** is not limited to the exemplary embodiment as illustrated in FIGS. **2A** and **2B**. Therefore, the above description should not be interpreted as a limitation on the scope of the disclosure but merely an illustration.

Although embodiments of the disclosure as illustrated in FIGS. **1A-7** illustrate a mid-depth joint or joining surface between the top slab **104** and the bottom slab **106** of the UHPC voided slab panel **102**, it is noted herein the joint or joining surface may be positioned closer to the top slab **104** and/or closer to the bottom slab **106**.

FIGS. **8A-8E** generally illustrate the UHPC voided slab panel **102**, in accordance with one or more embodiments of the disclosure.

The top slab **104** may include the top skin **120** and one or more span edges **112**. The bottom slab **104** may include the bottom skin **122**, one or more span edges **112**, and one or more ribs **118**. The one or more ribs **118** may define one or more voids **110** (and one or more void portions **110a**), and/or one or more voids **114**. The one or more ribs **118** may include the entire rib structure (e.g., as opposed to a partial rib structure as generally illustrated in FIGS. **1A-7**).

In one example, the one or more ribs **118** may be 20 inches tall, and may include one or more sections of varying widths through the height of 20 inches. For instance, the one or more ribs may have a section that changes from 10 inches wide to 2 inches wide along a height of 3.75 inches, may have a section that is 2 inches wide for a height of 1.125 inches, may have a section at least partially including an opening **800** that is 2 inches wide for a height of 10 inches, may have a section that is 2 inches wide for a height of 1.125 inches, may have a section that changes from 2 inches wide to 10 inches wide over a height of 2 inches, and may have a section that is 10 inches wide for a height of 2 inches.

As illustrated in FIG. **8C**, the opening **800** may be 2 feet in length by 2 inches in width by 10 inches in height or thickness. The opening **800** may include a 2-inch chamfer between the length and height sides.

It is noted herein that the ribs **118** and the opening **800** as illustrated in FIGS. **8A-8C** are only examples, and that the

ribs **118** and the opening **800** may be fabricated with dimensions that differ from those illustrated in FIGS. **8A-8C**. As such, the ribs **118** and the opening **800** are not limited to the examples as illustrated in FIGS. **8A-8C**. Therefore, the above description should not be interpreted as a limitation on the scope of the disclosure but merely an illustration.

The joint **108** between the top slab **104** and the bottom slab **106** may be between a surface **802** of the top slab **104** and a surface **804** of the bottom slab **106**. The joint **108** may be positioned nearly at the top of the UHPC voided slab panel **102** (e.g., as opposed to a mid-depth joint **108** as generally illustrated in FIGS. **1A-7**).

The top slab **104** may include a first component **806** and the bottom slab **106** may include a second component **808** of a connector assembly **810**. In general, the first component **806** and the second component **808** may include any respective cross-section.

For example, as illustrated in FIG. **8D**, the first component **806** may include a trapezoidal cross-section. The first component **806** may be tapered, such that the dimensions at the joint **108** are smaller than the dimensions at a select distance from the joint **108**. For example, the dimensions at the joint **108** may be 12 inches by 4 inches, while the dimensions at the select distance from mid-depth may be 13 inches by 5 inches, where the select distance is 1.5 inches.

By way of another example, as illustrated in FIG. **8E**, the second component **808** may include a trapezoidal cross-section. The one or more female keyed structures **402** may be tapered, such that the dimensions at the joint **108** are larger than the dimensions at a select distance from the joint **108**. For example, the dimensions at the joint **108** may be 12 inches by 4 inches, while the dimensions at the select distance from the joint **108** may be 11 inches by 3 inches, where the select distance is 1.5 inches.

It is noted herein that the first component **806** and the second component **808** as illustrated in FIGS. **8D** and **8E** are only examples, and that the first component **806** and the second component **808** may be fabricated with dimensions that differ from those illustrated in FIGS. **8D** and **8E**. As such, the first component **806** and the second component **808** are not limited to the examples as illustrated in FIGS. **8D** and **8E**. Therefore, the above description should not be interpreted as a limitation on the scope of the disclosure but merely an illustration.

The bottom slab **106** may be fabricated from UHPC. However, it is noted herein the top slab **104** may be fabricated from UHPC, cement board, plywood, raw wood, gypsum board, metal, or other material used in building and structure fabrication. Therefore, the above description should not be interpreted as a limitation on the scope of the disclosure but merely an illustration.

FIGS. **9A-9C** generally illustrate the UHPC voided slab panel **102**, in accordance with one or more embodiments of the disclosure.

The top slab **104** may include the top skin **120**, one or more span edges **112**, and one or more ribs **118**. The one or more ribs **118** may define one or more voids **110** (and one or more void portion **110a**), and/or one or more voids **114**. The one or more ribs **118** may include the entire rib structure (e.g., as opposed to a partial rib structure as generally illustrated in FIGS. **1A-7**). The bottom slab **104** may include the bottom skin **122**.

In one example, the one or more ribs **118** may be 21 inches tall, and may include one or more sections of varying widths through the height of 20 inches. For instance, the one

17

or more ribs may have a section that is 10 inches wide by 1 inch tall, a section that changes from 10 inches wide to 2 inches wide along a height of 3.75 inches, may have a section that is 2 inches wide for a height of 1.125 inches, may have a section at least partially including an opening **800** that is 2 inches wide for a height of 10 inches, may have a section that is 2 inches wide for a height of 1.125 inches, may have a section that changes from 2 inches wide to 10 inches wide over a height of 4 inches.

As illustrated in FIG. 9C, the opening **800** may be 2 feet in length by 2 inches in width by 10 inches in height or thickness. The opening **800** may include a 2-inch chamfer between the length and height sides. It is noted herein the opening **800** may form a portion of the one or more voids **114**.

It is noted herein that the ribs **118** and the opening **800** as illustrated in FIGS. 9A-9C are only examples, and that the ribs **118** and the opening **800** may be fabricated with dimensions that differ from those illustrated in FIGS. 9A-9C. As such, the ribs **118** and the opening **800** are not limited to the examples as illustrated in FIGS. 9A-9C. Therefore, the above description should not be interpreted as a limitation on the scope of the disclosure but merely an illustration.

The joint **108** between the top slab **104** and the bottom slab **106** may be between a surface **802** of the top slab **104** and a surface **804** of the bottom slab **106**. The joint **108** may be positioned nearly at the bottom of the UHPC voided slab panel **102** (e.g., as opposed to a mid-depth joint **108** as generally illustrated in FIGS. 1A-7).

The top slab **104** may be fabricated from UHPC. However, it is noted herein the bottom slab **106** may be fabricated from UHPC, cement board, plywood, raw wood, gypsum board, metal, or other material used in building and structure fabrication. Therefore, the above description should not be interpreted as a limitation on the scope of the disclosure but merely an illustration.

It is noted herein that the embodiments as generally illustrated in FIGS. 1A-7 may apply to the UHPC voided slab panel **102** and any components of the UHPC voided slab panel **102** as generally illustrated in FIGS. 8A-8E and/or FIGS. 9A-9C, to the extent the embodiments directed to FIGS. 1A-7 do not conflict with the embodiments directed to FIGS. 8A-8E and/or FIGS. 9A-9C, and vice versa. Therefore, the above description should not be interpreted as a limitation on the scope of the disclosure but merely an illustration.

FIG. 10 illustrates a method or process **1000** for manufacturing the UHPC voided slab panel **102**, in accordance with one or more embodiments of the disclosure. It is noted herein the method or process **1000** may be understood as being illustrated in detail in FIGS. 2A-9C and the accompanying embodiments in the disclosure.

In a step **1002**, a top slab of a UHPC voided slab panel may be fabricated. One or more prestressing strands may be pre-tensioned within the formwork **200**. One or more sleeves or blockouts **210** may be inserted within the formwork **200**. For example, the one or more sleeves or blockouts **210** may be removable. By way of another example, the one or more sleeves or blockouts **210** may be left in the top slab **104**.

UHPC may be poured within the one or more rib portions **208** of the formwork **200** to form the one or more ribs **118**. UHPC may be poured within the one or more skin portions **206** of the formwork **200** to form the top skin **120** and the one or more span edges **112** of the top slab **104**. For example, the UHPC may be poured to form the top skin **120** and the

18

one or more span edges **112** following a select amount of time to allow the one or more ribs **118** to set. It is noted herein, however, that UHPC may be poured for the one or more ribs **118**, the top skin **120**, and the one or more span edges **112** simultaneously or substantially simultaneously.

The top slab **104** may include one or more holes **410**. For example, the one or more holes **410** may be formed by the removable sleeves or blockouts **210**. By way of another example, the one or more holes **410** may be within the removable sleeves or blockouts **210** left in the top slab **104**.

Following the pouring of the UHPC and after a select amount of time to allow for the one or more ribs **118**, the top skin **120**, and/or the one or more span edges **112** to set, the one or more prestressing strands may be de-tensioned and the top slab **104** may be removed.

In a step **1004**, a bottom slab of a UHPC voided slab panel is fabricated. One or more prestressing strands may be pre-tensioned within the formwork **200**. One or more sleeves or blockouts **210** may be inserted within the formwork **200**. For example, the one or more sleeves or blockouts **210** may be removable. By way of another example, the one or more sleeves or blockouts **210** may be left in the top slab **104**.

UHPC may be poured within the one or more rib portions **208** of the formwork **200** to form the one or more ribs **118**. UHPC may be poured within the one or more skin portions **206** of the formwork **200** to form the bottom skin **122** and the one or more span edges **112** of the bottom slab **106**. For example, the UHPC may be poured to form the bottom skin **122** and the one or more span edges **112** following a select amount of time to allow the one or more ribs **118** to set. It is noted herein, however, that UHPC may be poured for the one or more ribs **118**, the bottom skin **122**, and the one or more span edges **112** simultaneously or substantially simultaneously.

The bottom slab **106** may include one or more holes **410**. For example, the one or more holes **410** may be formed by the removable sleeves or blockouts **210**. By way of another example, the one or more holes **410** may be within the removable sleeves or blockouts **210** left in the bottom slab **106**.

In a step **1006**, utilities may be installed in the bottom slab of the UHPC voided slab panel. The utilities may be installed within the one or more voids **110** and/or the one or more voids **114** between the one or more ribs of the bottom slab **106**.

It is noted herein, however, that step **1006** may be optional, as the utilities may be installed following step **1008** and/or during or following the installation of the UHPC voided slab panel **102** at the job site. Therefore, the above description should not be interpreted as a limitation on the scope of the disclosure but merely an illustration.

In a step **1008**, the top slab and the bottom slab of the UHPC voided slab panel may be joined. Where the bottom slab **106** includes the one or more rods **600**, the one or more rods **600** may be aligned within the one or more holes **410** within the top slab **104**. The joint material **700** may be inserted in the joint **108** prior to the joining of the top slab **104** and the bottom slab **106**.

Following the joining of the top slab **104** and the bottom slab **106** and after a select amount of time to allow for the joint material **700** to set, the one or more prestressing strands may be de-tensioned and the bottom slab **106** may be removed. It is noted herein, however, that the one or more prestressing strands may be de-tensioned and the bottom slab **106** may be removed following a select amount of time to allow the bottom skin **122** and the span edges **112** of the

bottom slab **106** to set, prior to the joining with the top slab **104**. Therefore, the above description should not be interpreted as a limitation on the scope of the disclosure but merely an illustration.

It is noted herein the method or process **1000** is not limited to the steps and/or sub-steps provided. The method or process **1000** may include more or fewer steps and/or sub-steps. The method or process **1000** may perform the steps and/or sub-steps simultaneously. The method or process **1000** may perform the steps and/or sub-steps sequentially, including in the order provided or an order other than provided. Therefore, the above description should not be interpreted as a limitation on the scope of the disclosure but merely an illustration.

In an exemplary embodiment, the finished UHPC voided slab panel **102** may be 60 feet by 12 feet by 22 inches in size. The finished UHPC voided slab panel **102** may weigh approximately 15 tons, or approximately 29,000 pounds, which is a much lighter weight than alternative, currently available products known in the art. The finished UHPC voided slab panel **102** may have a load rating of 100 pounds per square foot (lbs/sqft), which is a much higher strength rating than alternative, currently available products known in the art. It is noted herein this load rating is well in excess of the required ratings for apartment buildings and parking structures (e.g., 40 lbs/sqft) and commercial structures (e.g., 50 lbs/sqft).

Advantages of the disclosure include an ultra high performance concrete voided slab system including one or more ultra high performance concrete (UHPC) voided slab panels, where a voided slab panel includes a top slab and a bottom slab, where one or more voids are formed between the top slab and the bottom slab. Advantages of the disclosure are also directed to prestressing strands (or cables) embedded longitudinally in the top slab and/or the bottom slab to ensure adequate flexural (e.g., bending) capacity of the UHPC voided slab panel. Advantages of the disclosure also include using steel fibers instead of rebar and/or shearing reinforcements, resulting in a system that is easier to manufacture and is thinner than conventional concrete slabs.

One skilled in the art will recognize that the herein described components (e.g., operations), devices, objects, and the discussion accompanying them are used as examples for the sake of conceptual clarity and that various configuration modifications are contemplated. Consequently, as used herein, the specific exemplars set forth and the accompanying discussion are intended to be representative of their more general classes. In general, use of any specific exemplar is intended to be representative of its class, and the non-inclusion of specific components (e.g., operations), devices, and objects should not be taken limiting.

Although a user is described herein as a single figure, those skilled in the art will appreciate that the user may be representative of a human user, a robotic user (e.g., computational entity), and/or substantially any combination thereof (e.g., a user may be assisted by one or more robotic agents) unless context dictates otherwise. Those skilled in the art will appreciate that, in general, the same may be said of "sender" and/or other entity-oriented terms as such terms are used herein unless context dictates otherwise.

With respect to the use of substantially any plural and/or singular terms herein, those having skill in the art can translate from the plural to the singular and/or from the singular to the plural as is appropriate to the context and/or application. The various singular/plural permutations are not expressly set forth herein for sake of clarity.

The herein described subject matter sometimes illustrates different components contained within, or connected with, different other components. It is to be understood that such depicted architectures are merely exemplary, and that in fact many other architectures may be implemented which achieve the same functionality. In a conceptual sense, any arrangement of components to achieve the same functionality is effectively "associated" such that the desired functionality is achieved. Hence, any two components herein combined to achieve a particular functionality can be seen as "associated with" each other such that the desired functionality is achieved, irrespective of architectures or intermedial components. Likewise, any two components so associated can also be viewed as being "operably connected", or "operably coupled," to each other to achieve the desired functionality, and any two components capable of being so associated can also be viewed as being "operably coupleable," to each other to achieve the desired functionality. Specific examples of operably coupleable include but are not limited to physically mateable and/or physically interacting components.

In some instances, one or more components may be referred to herein as "configured to," "configurable to," "operable/operative to," "adapted/adaptable," "able to," "conformable/conformed to," or the like. Those skilled in the art will recognize that such terms (e.g., "configured to") can generally encompass active-state components and/or inactive-state components and/or standby-state components, unless context requires otherwise.

While particular aspects of the present subject matter described herein have been shown and described, it will be apparent to those skilled in the art that, based upon the teachings herein, changes and modifications may be made without departing from the subject matter described herein and its broader aspects and, therefore, the appended claims are to encompass within their scope all such changes and modifications as are within the true spirit and scope of the subject matter described herein. It will be understood by those within the art that, in general, terms used herein, and especially in the appended claims (e.g., bodies of the appended claims) are generally intended as "open" terms (e.g., the term "including" should be interpreted as "including but not limited to," the term "having" should be interpreted as "having at least," the term "includes" should be interpreted as "includes but is not limited to," or the like). It will be further understood by those within the art that if a specific number of an introduced claim recitation is intended, such an intent will be explicitly recited in the claim, and in the absence of such recitation no such intent is present. For example, as an aid to understanding, the following appended claims may contain usage of the introductory phrases "at least one" and "one or more" to introduce claim recitations. However, the use of such phrases should not be construed to imply that the introduction of a claim recitation by the indefinite articles "a" or "an" limits any particular claim containing such introduced claim recitation to claims containing only one such recitation, even when the same claim includes the introductory phrases "one or more" or "at least one" and indefinite articles such as "a" or "an" (e.g., "a" and/or "an" should typically be interpreted to mean "at least one" or "one or more"); the same holds true for the use of definite articles used to introduce claim recitations. In addition, even if a specific number of an introduced claim recitation is explicitly recited, those skilled in the art will recognize that such recitation should typically be interpreted to mean at least the recited number (e.g., the bare recitation of "two recitations," without other modifiers, typically

means at least two recitations, or two or more recitations). Furthermore, in those instances where a convention analogous to “at least one of A, B, and C, or the like” is used, in general such a construction is intended in the sense one having skill in the art would understand the convention (e.g., “a system having at least one of A, B, and C” would include but not be limited to systems that have A alone, B alone, C alone, A and B together, A and C together, B and C together, and/or A, B, and C together, or the like). In those instances where a convention analogous to “at least one of A, B, or C, or the like” is used, in general such a construction is intended in the sense one having skill in the art would understand the convention (e.g., “a system having at least one of A, B, or C” would include but not be limited to systems that have A alone, B alone, C alone, A and B together, A and C together, B and C together, and/or A, B, and C together, or the like). It will be further understood by those within the art that typically a disjunctive word and/or phrase presenting two or more alternative terms, whether in the description, claims, or drawings, should be understood to contemplate the possibilities of including one of the terms, either of the terms, or both terms unless context dictates otherwise. For example, the phrase “A or B” will be typically understood to include the possibilities of “A” or “B” or “A and B.”

With respect to the appended claims, those skilled in the art will appreciate that recited operations therein may generally be performed in any order. Also, although various operational flows are presented in a sequence(s), it should be understood that the various operations may be performed in other orders than those which are illustrated, or may be performed concurrently. Examples of such alternate orderings may include overlapping, interleaved, interrupted, reordered, incremental, preparatory, supplemental, simultaneous, reverse, or other variant orderings, unless context dictates otherwise. Furthermore, terms like “responsive to,” “related to,” or other past-tense adjectives are generally not intended to exclude such variants, unless context dictates otherwise.

Although particular embodiments of this invention have been illustrated, it is apparent that various modifications and embodiments of the invention may be made by those skilled in the art without departing from the scope and spirit of the foregoing disclosure. Accordingly, the scope of the invention should be limited only by the claims appended hereto.

What is claimed:

1. An ultra high performance concrete (UHPC) voided slab panel, comprising:

a top slab including a top skin and a bottom slab including a bottom skin, the top slab and the bottom slab being joined at a joint positioned a select height within the UHPC voided slab panel, the joint being filled with a joint material during the joining of the top slab and the bottom slab, the top slab and the bottom slab being joined via a connector assembly; and

at least two ribs, the at least two ribs defining at least one void, the at least one void being accessible via at least one opening within an exterior surface of the UHPC voided slab panel,

the top slab and the bottom slab each being fabricated from UHPC and a plurality of embedded prestressing strands, the top slab and the bottom slab being joined via the connector assembly subsequent to at least the top slab being fabricated,

the UHPC voided slab panel being configured to meet select strength requirements that are greater than select

strength requirements for conventional precast concrete without reinforcing bars being embedded within the UHPC voided slab panel.

2. The panel in claim **1**, the at least one void configured to house one or more utility components, the one or more utility components being configured to transfer one or more utilities through the UHPC voided slab panel.

3. The panel in claim **1**, the at least one void being accessible via at least one opening within an exterior span surface of the UHPC voided slab panel or via at least one opening within an exterior width surface of the UHPC voided slab panel.

4. The panel in claim **1**, the at least one void including a first void accessible via at least one opening within a span surface of a span of the UHPC voided slab panel and a second void accessible via at least one opening within a width surface of the UHPC voided slab panel.

5. The panel in claim **1**, the select height being at mid-depth of the UHPC voided slab panel, a first portion of each of the at least two ribs being formed with the top slab and a corresponding second portion of each of the at least two ribs being formed with the bottom slab.

6. The panel in claim **5**, the first portion of each of the at least two ribs and the corresponding second portion of each of the at least two ribs being coupled together via the connector assembly, the connector assembly including a keyed assembly with a male keyed structure and a female keyed structure, the male keyed structure configured to interlock with the female keyed structure, the male keyed structure configured to pass through a plane when interlocking with the female keyed structure, the plane being at mid-depth of the UHPC voided slab panel.

7. The panel in claim **6**, a first portion of a first rib of the at least two ribs including a male keyed structure and a corresponding second portion of the first rib of the at least two ribs including a corresponding female keyed structure, a first portion of a second rib of the at least two ribs including a female keyed structure and a corresponding second portion of the second rib of the at least two ribs including a corresponding male keyed structure.

8. The panel in claim **1**, the select height being proximate to the top slab of the UHPC voided slab panel.

9. The panel in claim **8**, the at least two ribs being formed with the bottom slab.

10. The panel in claim **9**, the top slab including a first component of the connector assembly, the at least two ribs formed with the bottom slab including a second component of the connector assembly.

11. The panel in claim **1**, the select height being proximate to the bottom slab of the UHPC voided slab panel.

12. The panel in claim **11**, the at least two ribs being formed with the top slab.

13. The panel in claim **12**, the bottom slab including a first component of the connector assembly, the at least two ribs formed with the top slab including a second component of the connector assembly.

14. The panel in claim **1**, the connector assembly including at least one rod in the bottom slab and at least one hole in the top slab, the at least one hole configured to receive the at least one rod when the top slab and the bottom slab are joined.

15. The panel in claim **14**, the at least one rod configured to be inserted within the at least two ribs.

16. An ultra high performance concrete voided slab system, comprising:

23

- a plurality of ultra high performance concrete (UHPC) voided slab panels, each UHPC voided slab panel of the plurality of UHPC voided slab panels comprising:
 - a top slab including a top skin and a bottom slab including a bottom skin, the top slab and the bottom slab being joined at a joint positioned a select height within the UHPC voided slab panel, the joint may be filled with a joint material during the joining of the top slab and the bottom slab, the top slab and the bottom slab being joined via a connector assembly; and
 - at least two ribs, the at least two ribs defining at least one void, the at least one void being accessible via at least one opening within an exterior surface of the UHPC voided slab panel,
 - the top slab and the bottom slab being fabricated from UHPC and a plurality of embedded prestressing strands, the top slab and the bottom slab being joined via the connector assembly subsequent to at least the top slab being fabricated,
 - the UHPC voided slab panel being configured to meet select strength requirements that are greater than select strength requirements for conventional precast concrete without reinforcing bars being embedded within the UHPC voided slab panel.
- 17. The system in claim 16, each UHPC voided slab panel of the plurality of UHPC voided slab panels comprising:
 - a span edge on at least one of the top slab or the bottom slab,
 - adjacent UHPC voided slab panels of the plurality of the UHPC voided slab panel being couplable together via adjacent span edges of the adjacent UHPC voided slab panels.
- 18. A method of making the panel in claim 1, the method comprising:
 - fabricating a top slab of an ultra high performance concrete (UHPC) voided slab panel with a top formwork, the fabricating the top slab comprising:
 - pouring a first amount of UHPC within at least two rib portions to fabricate at least two ribs, the space between the at least two ribs defining at least one void; and

24

- pouring a second amount of UHPC within at least one skin portion to fabricate a top skin,
- the top formwork including a plurality of prestressing strands positioned to be embedded during the pouring of the at least one of the first amount of UHPC or during the pouring of the second amount of UHPC;
- fabricating a bottom slab of the UHPC voided slab panel with a bottom formwork, the fabricating the bottom slab comprising:
 - pouring a first amount of UHPC within at least two rib portions to fabricate at least two ribs, the space between the at least two ribs defining at least one void; and
 - pouring a second amount of UHPC within at least one skin portion to fabricate a bottom skin, the bottom formwork including a plurality of prestressing strands positioned to be embedded during the pouring of the at least one of the first amount of UHPC or during the pouring of the second amount of UHPC; and
- joining the top slab of the UHPC voided slab panel and the bottom slab of the UHPC voided slab panel together via a connector assembly, the joint being filled with a joint material during the joining of the top slab and the bottom slab,
- the UHPC voided slab panel being configured to meet select strength requirements that are greater than select strength requirements for conventional precast concrete without reinforcing bars being embedded within the UHPC voided slab panel.
- 19. The method in claim 18, comprising:
 - installing one or more utility components within the at least one void, the one or more utility components being configured to transfer one or more utilities through the UHPC voided slab panel.
- 20. The method in claim 18, the top formwork and the bottom formwork being a single formwork, the top slab being fabricated before the bottom slab, the fabricated top slab being removed from the single formwork prior to the fabricating of the bottom slab.

* * * * *