



US00D759195S

(12) **United States Design Patent**
Tanida et al.

(10) **Patent No.:** **US D759,195 S**

(45) **Date of Patent:** **** Jun. 14, 2016**

(54) **FILTER ELEMENT FOR BALLAST WATER TREATMENT**

(71) Applicant: **SUMITOMO ELECTRIC INDUSTRIES, LTD.**, Osaka-shi, Osaka (JP)

(72) Inventors: **Kazuhiro Tanida**, Osaka (JP); **Munetsugu Ueyama**, Osaka (JP); **Masaki Mori**, Osaka (JP); **Shinichi Kanazawa**, Osaka (JP)

(73) Assignee: **SUMITOMO ELECTRIC INDUSTRIES, LTD.**, Osaka-shi, Osaka (JP)

(**) Term: **14 Years**

(21) Appl. No.: **29/516,564**

(22) Filed: **Feb. 4, 2015**

(30) **Foreign Application Priority Data**

Oct. 8, 2014 (JP) 2014-022589
Oct. 8, 2014 (JP) 2014-022590

(51) **LOC (10) Cl.** **23-01**

(52) **U.S. Cl.**
USPC **D23/209**

(58) **Field of Classification Search**

USPC D23/207, 209, 365; D15/5; 210/483, 210/493.1, 495, 499, 497.01, 282, 232
CPC B01D 35/02
See application file for complete search history.

(56) **References Cited**

U.S. PATENT DOCUMENTS

2,895,174 A * 7/1959 Hockett B01D 46/0001
210/493.1
3,807,150 A * 4/1974 Maracle B01D 46/523
210/493.1
D351,650 S * 10/1994 Vavra D23/365
D407,808 S * 4/1999 Nepsund D23/365
D530,807 S * 10/2006 Miyagishima D15/5

D638,034 S * 5/2011 Jiang D15/5
8,534,468 B2 * 9/2013 Winkler B01D 33/067
162/251
D694,871 S * 12/2013 Maholick D23/365
D724,179 S * 3/2015 Keenan D23/209

FOREIGN PATENT DOCUMENTS

JP 2014-073486 4/2014

OTHER PUBLICATIONS

“Pleated Cartridge Filter Product Guide”, JPO Industrial Design Section Publicly Known Material No. HC21021021, p. 2.

* cited by examiner

Primary Examiner — Robin V Webster

(74) *Attorney, Agent, or Firm* — Drinker Biddle & Reath LLP

(57) **CLAIM**

The ornamental design for a filter element for ballast water treatment, as shown and described.

DESCRIPTION

FIG. 1 is a front view of a first embodiment of a filter element for ballast water treatment of the present invention. FIG. 2 is a rear view of the first embodiment of the filter element for ballast water treatment of FIG. 1. FIG. 3 is a top plan view of the first embodiment of the filter element for ballast water treatment of FIG. 1. FIG. 4 is a bottom view of the first embodiment of the filter element for ballast water treatment of FIG. 1. FIG. 5 is a right side view of the first embodiment of the filter element for ballast water treatment of FIG. 1. FIG. 6 is a left side view of the first embodiment of the filter element for ballast water treatment of FIG. 1. FIG. 7 is a perspective view of the first embodiment of the filter element for ballast water treatment of FIG. 1. FIG. 8 is a sectional view of the first embodiment of the filter element for ballast water treatment of FIG. 1, taken along the line 8-8 of FIG. 3.

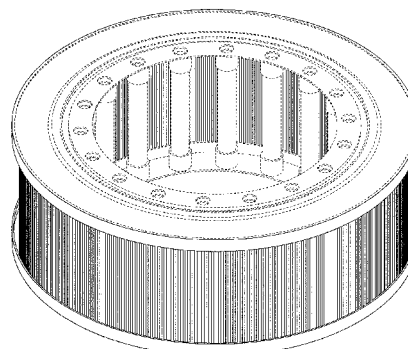
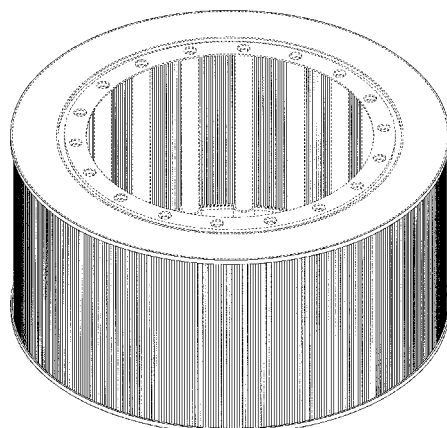

FIG. 9 is a sectional view of the first embodiment of the filter element for ballast water treatment of FIG. 1, taken along the line 9-9 of FIG. 1.

FIG. 10 is an enlarged sectional view of the first embodiment of the filter element for ballast water treatment of FIG. 1, taken along the line 10-10 of FIG. 8.

FIG. 11 is an enlarged sectional view of the first embodiment of the filter element for ballast water treatment of FIG. 1, taken along the line 11-11 of FIG. 8.

FIG. 12 is an enlarged sectional view of the first embodiment of the filter element for ballast water treatment of FIG. 1, taken along the line 12-1, 12-1 and 12-2, 12-2 of FIG. 9.

FIG. 13 is a reference view of the first embodiment of the filter element for ballast water treatment of FIG. 1 in use, wherein the filter elements are connected vertically and mounted to a ballast water treatment equipment, which is for illustrative purpose only and form no part of the claimed design.

FIG. 14 is a front view of a second embodiment of a filter element for ballast water treatment of the present invention.

FIG. 15 is a rear view of the second embodiment of the filter element for ballast water treatment of FIG. 14.

FIG. 16 is a top plan view of the second embodiment of the filter element for ballast water treatment of FIG. 14.

FIG. 17 is a bottom view of the second embodiment of the filter element for ballast water treatment of FIG. 14.

FIG. 18 is a right side view of the second embodiment of the filter element for ballast water treatment of FIG. 14.

FIG. 19 is a left side view of the second embodiment of the filter element for ballast water treatment of FIG. 14.

FIG. 20 is a perspective view of the second embodiment of the filter element for ballast water treatment of FIG. 14.

FIG. 21 is a sectional view of the second embodiment of the filter element for ballast water treatment of FIG. 14, taken along the line 21-21 of FIG. 16.

FIG. 22 is a sectional view of the second embodiment of the filter element for ballast water treatment of FIG. 14, taken along the line 22-22 of FIG. 14.

FIG. 23 is an enlarged sectional view of the second embodiment of the filter element for ballast water treatment of FIG. 14, taken along the line 23-23 of FIG. 21.

FIG. 24 is an enlarged sectional view of the second embodiment of the filter element for ballast water treatment of FIG. 14, taken along the line 24-24 of FIG. 21.

FIG. 25 is an enlarged sectional view of the second embodiment of the filter element for ballast water treatment of FIG. 14, taken along the line 25-1, 25-1 and 25-2, 25-2 of FIG. 22; and,

FIG. 26 is a reference view of the second embodiment of the filter element for ballast water treatment of FIG. 14 in use, wherein the filter elements are connected vertically and mounted to a ballast water treatment equipment, which is for illustrative purpose only and form no part of the claimed design.

The features shown in broken lines depict environmental subject matter only and form no part of the claimed design.

1 Claim, 26 Drawing Sheets

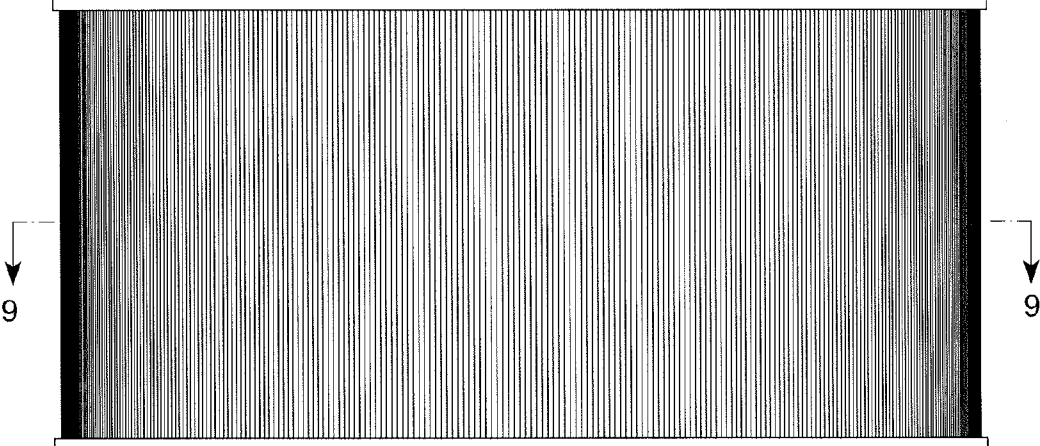

Fig.1

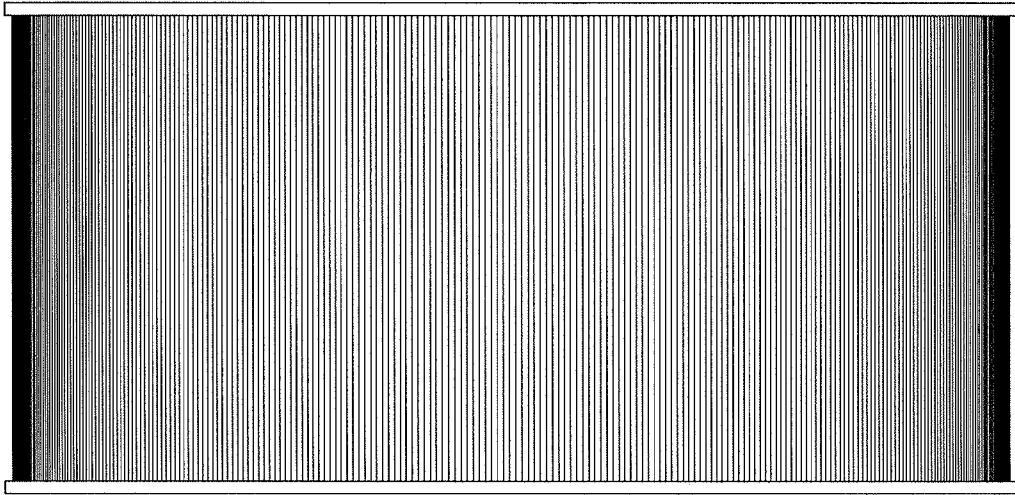

Fig.2

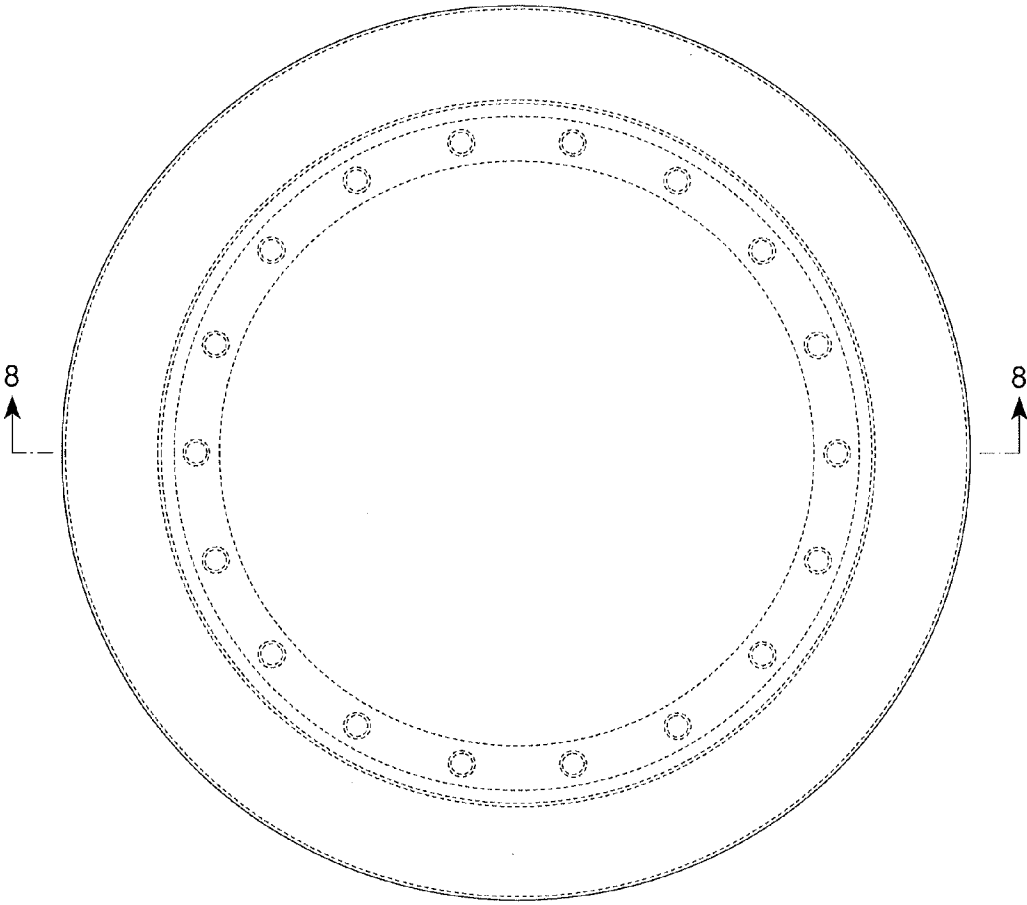

Fig.3

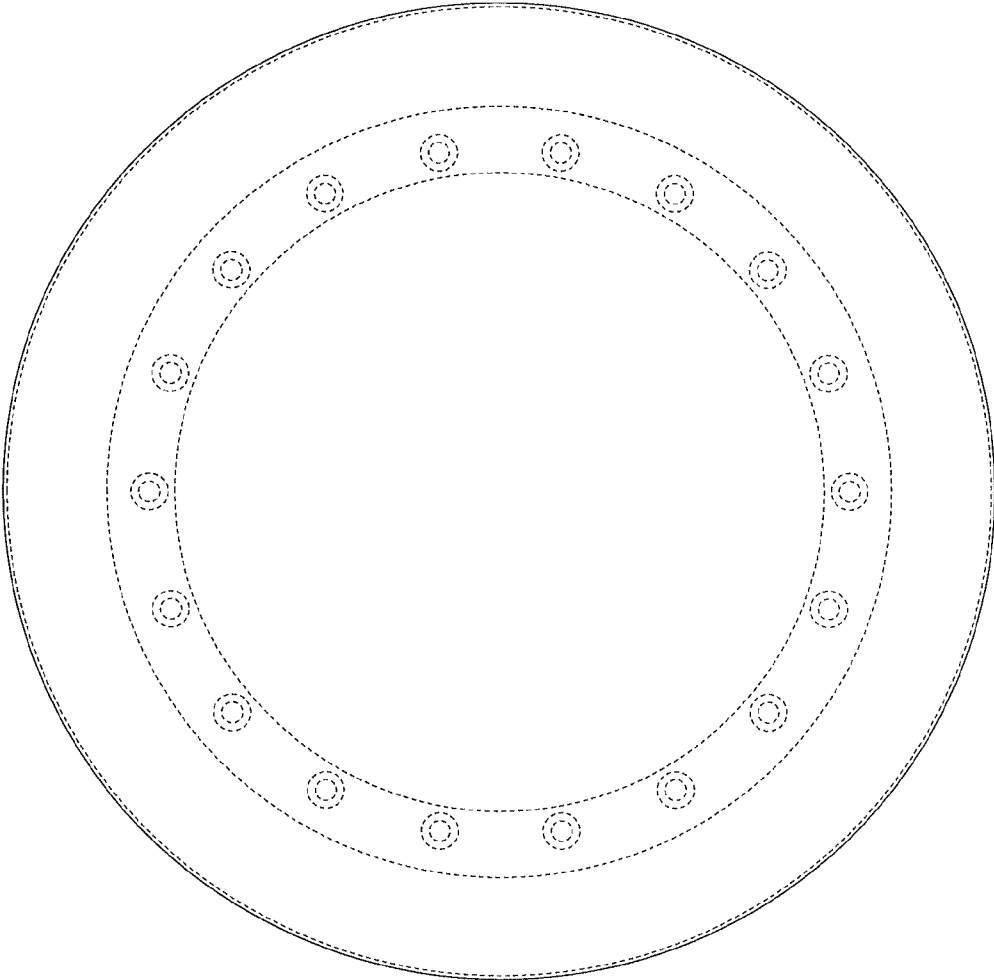

Fig.4

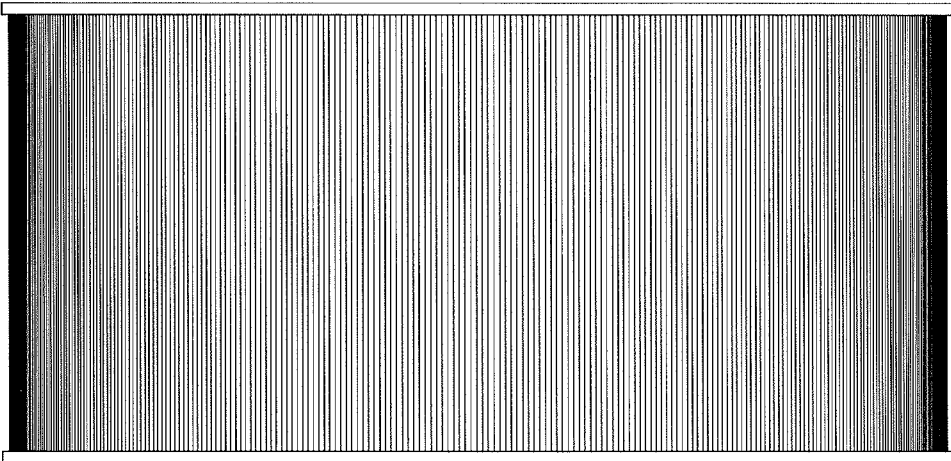

Fig.5

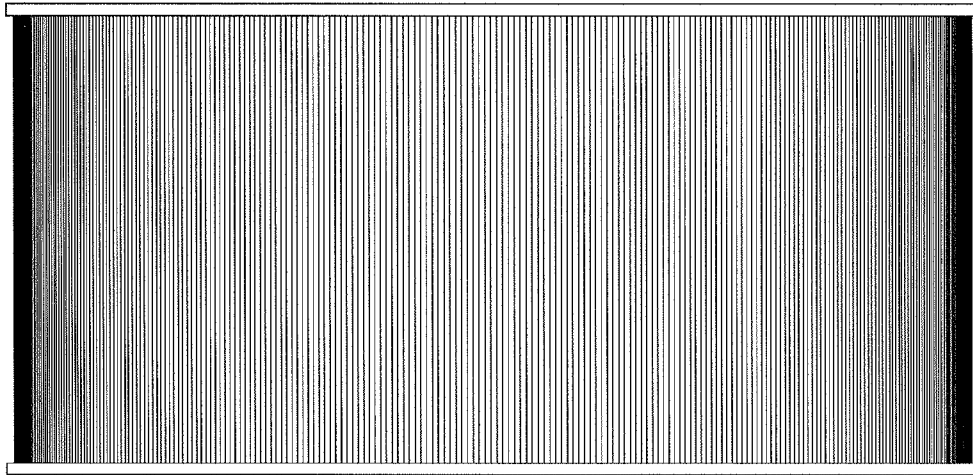

Fig.6

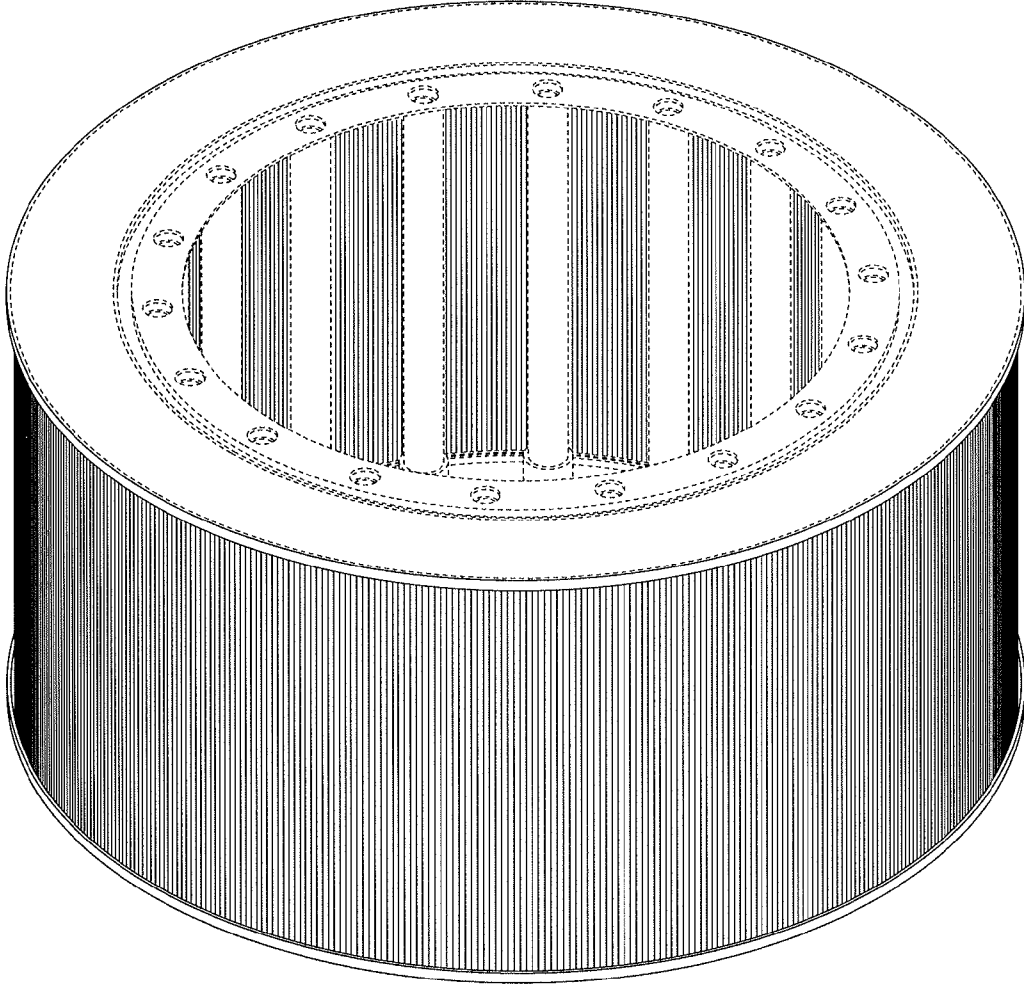

Fig.7

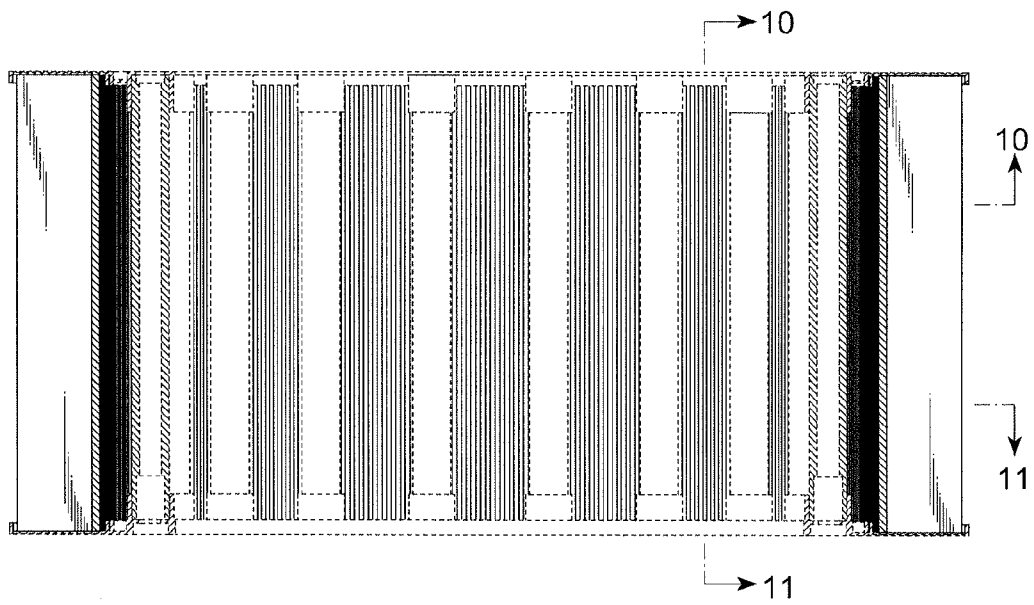

Fig.8

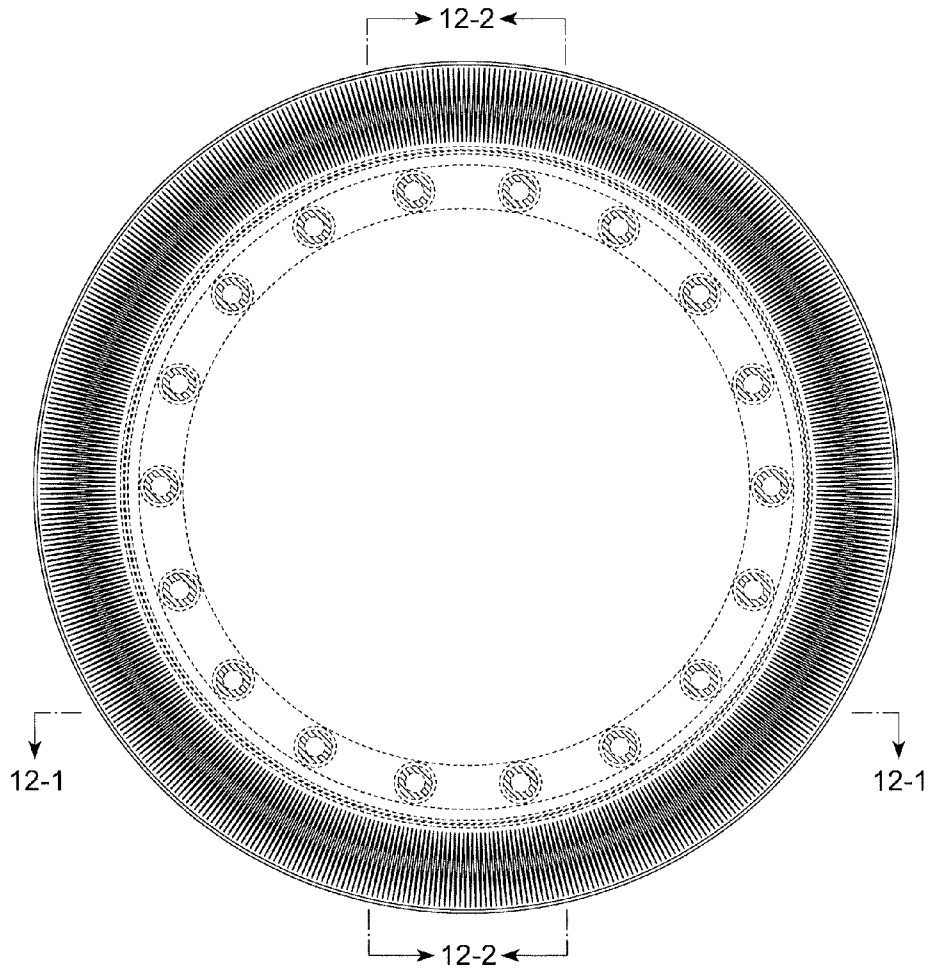

Fig.9

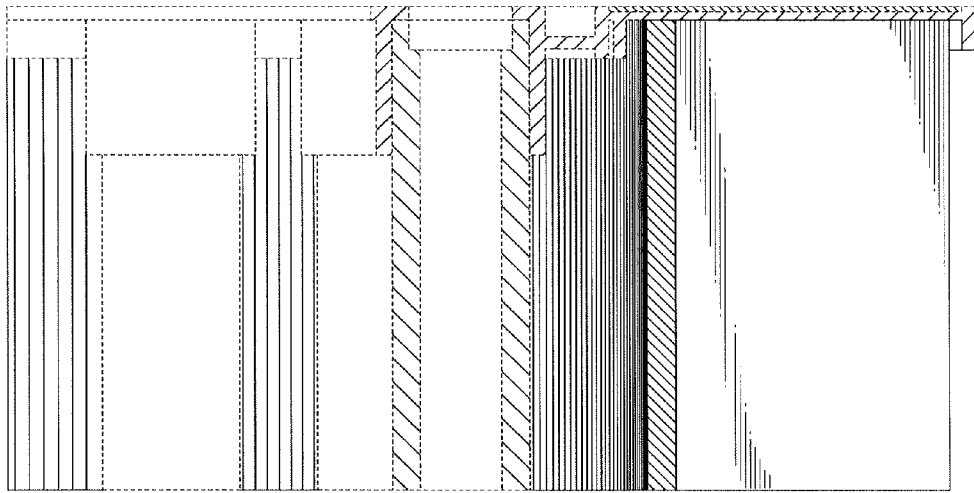

Fig.10

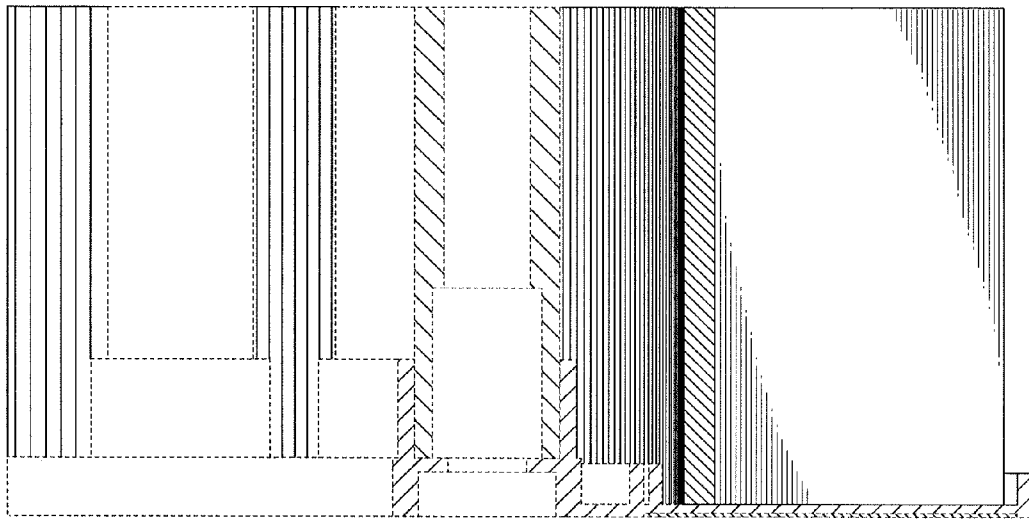

Fig.11

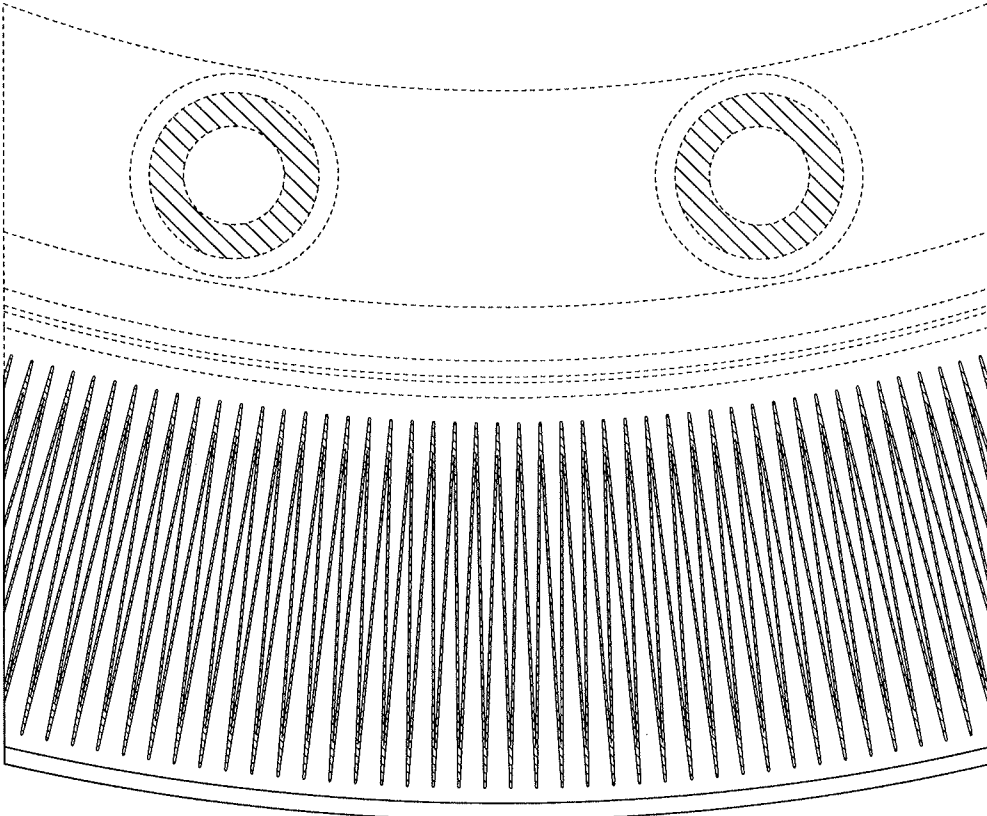

Fig.12

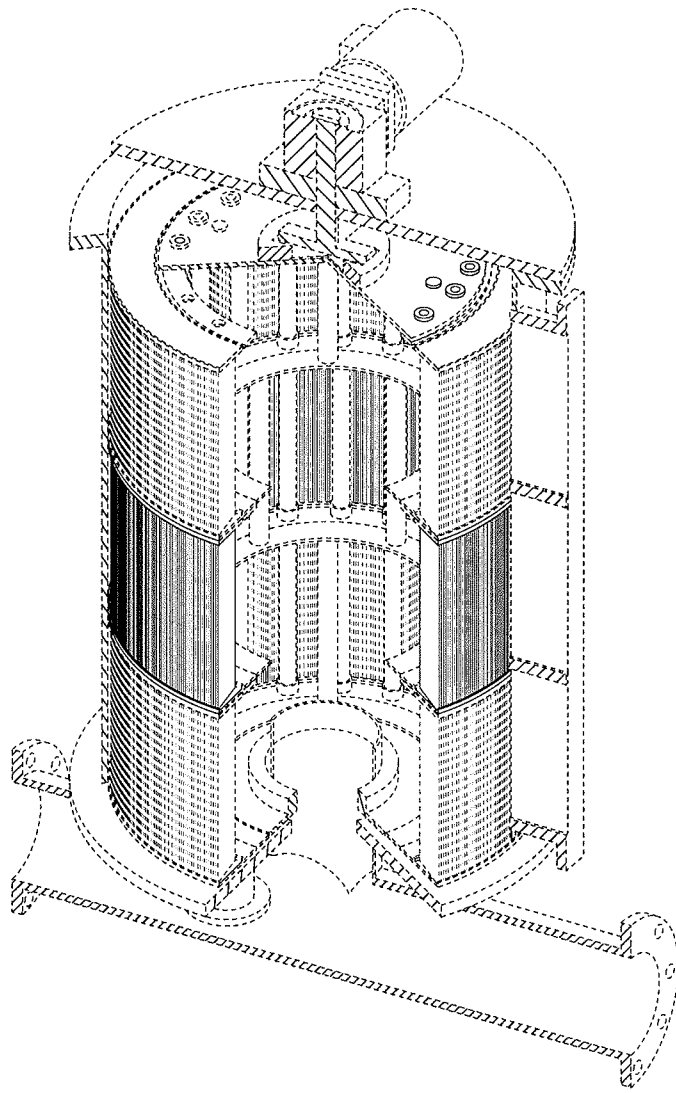

Fig.13

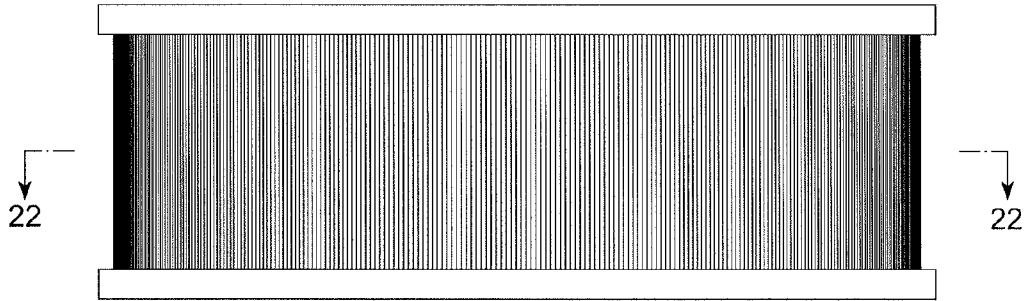

Fig.14

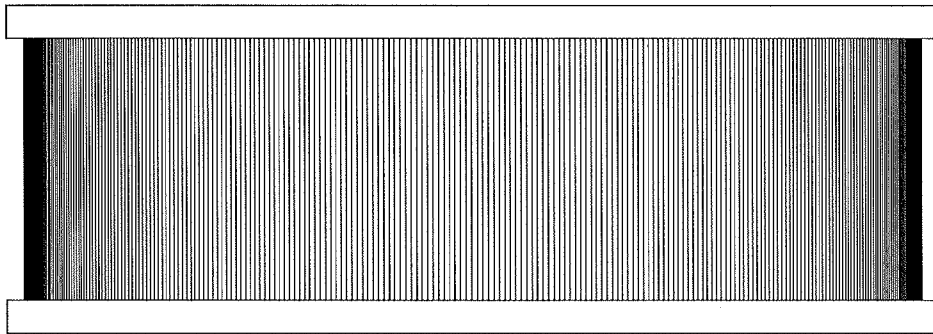

Fig.15

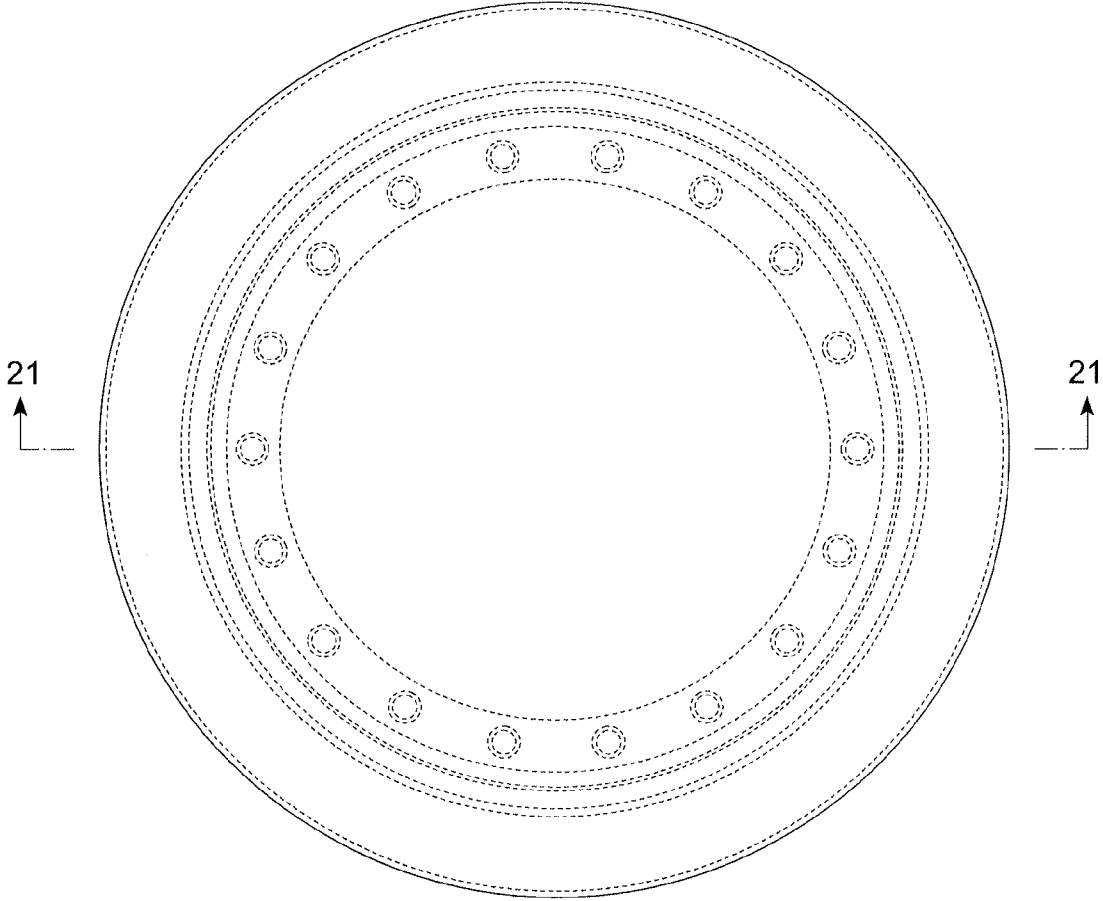

Fig.16

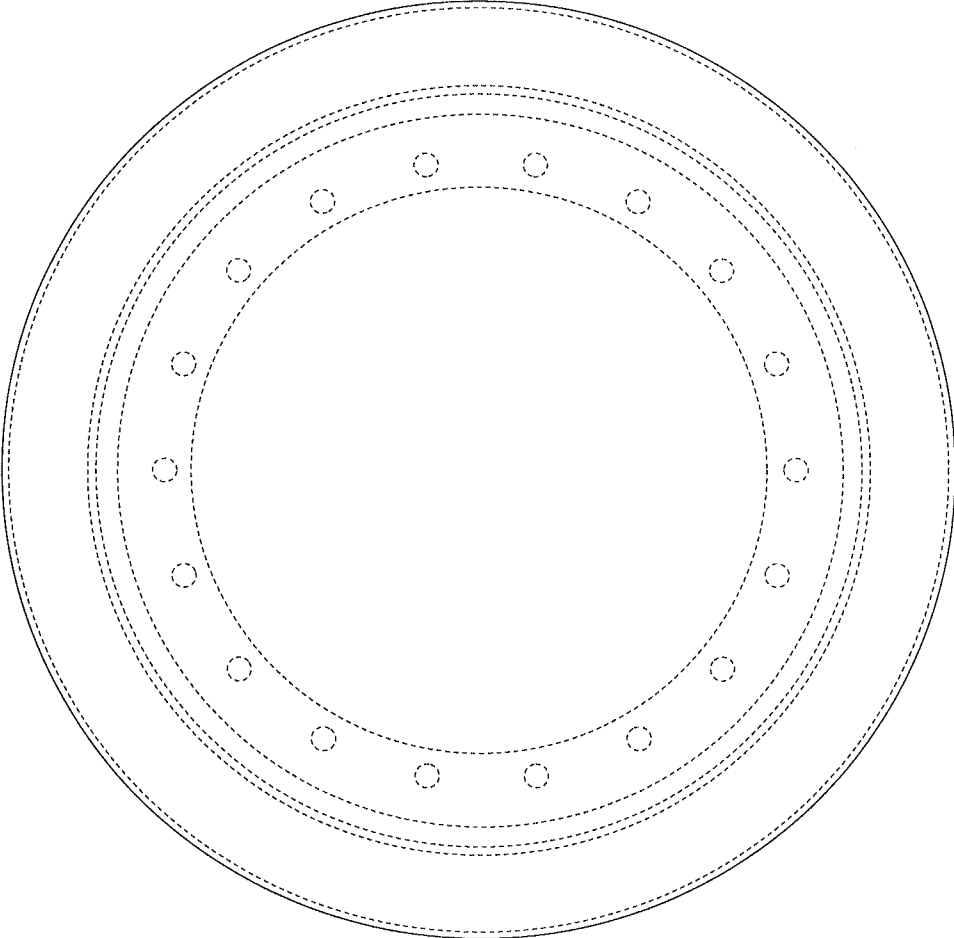

Fig.17

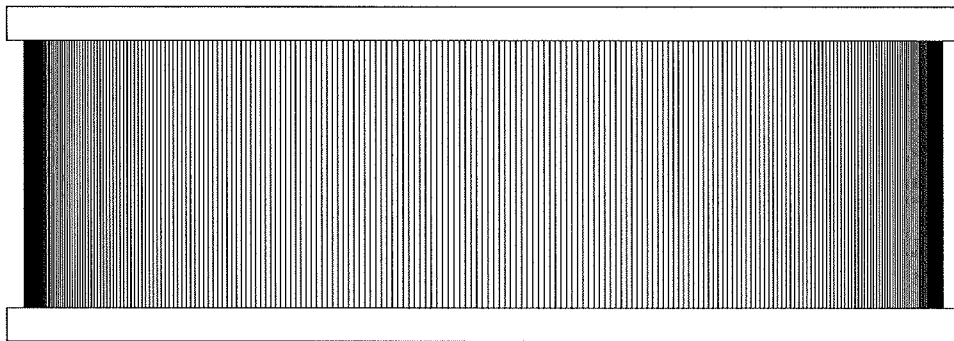

Fig.18

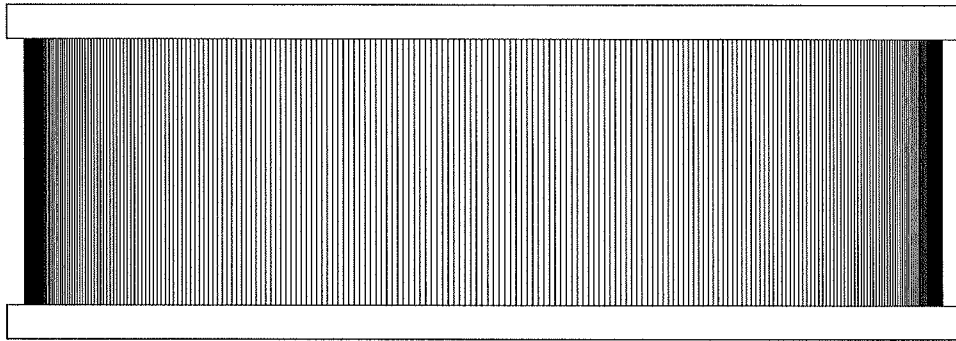

Fig.19

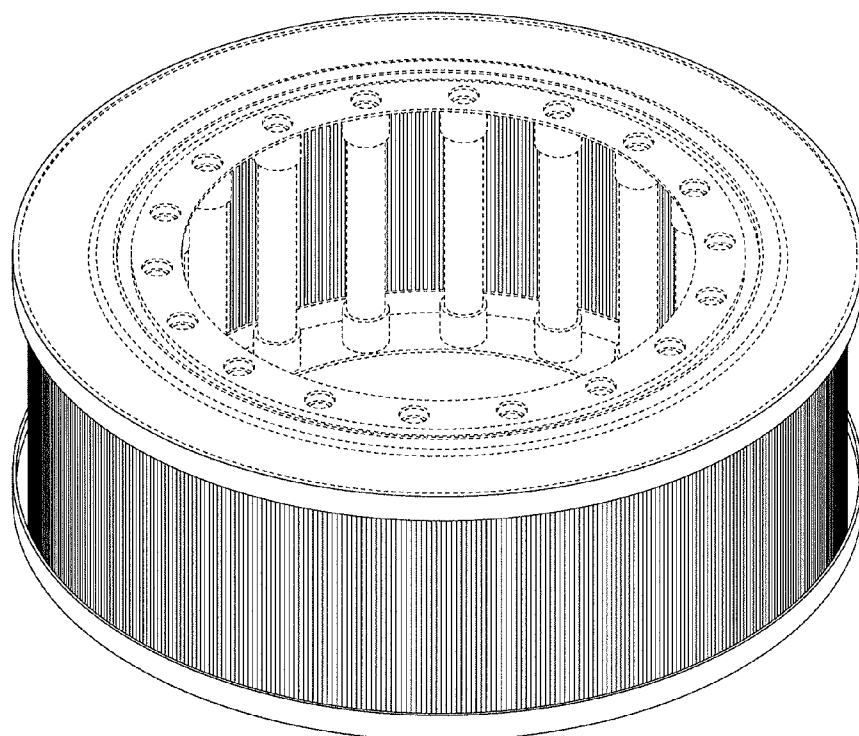

Fig.20

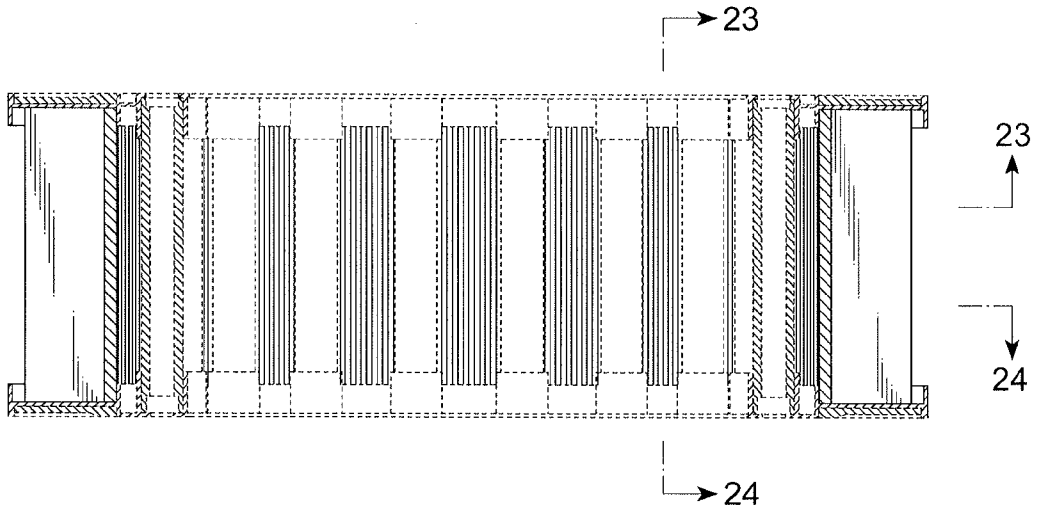

Fig.21

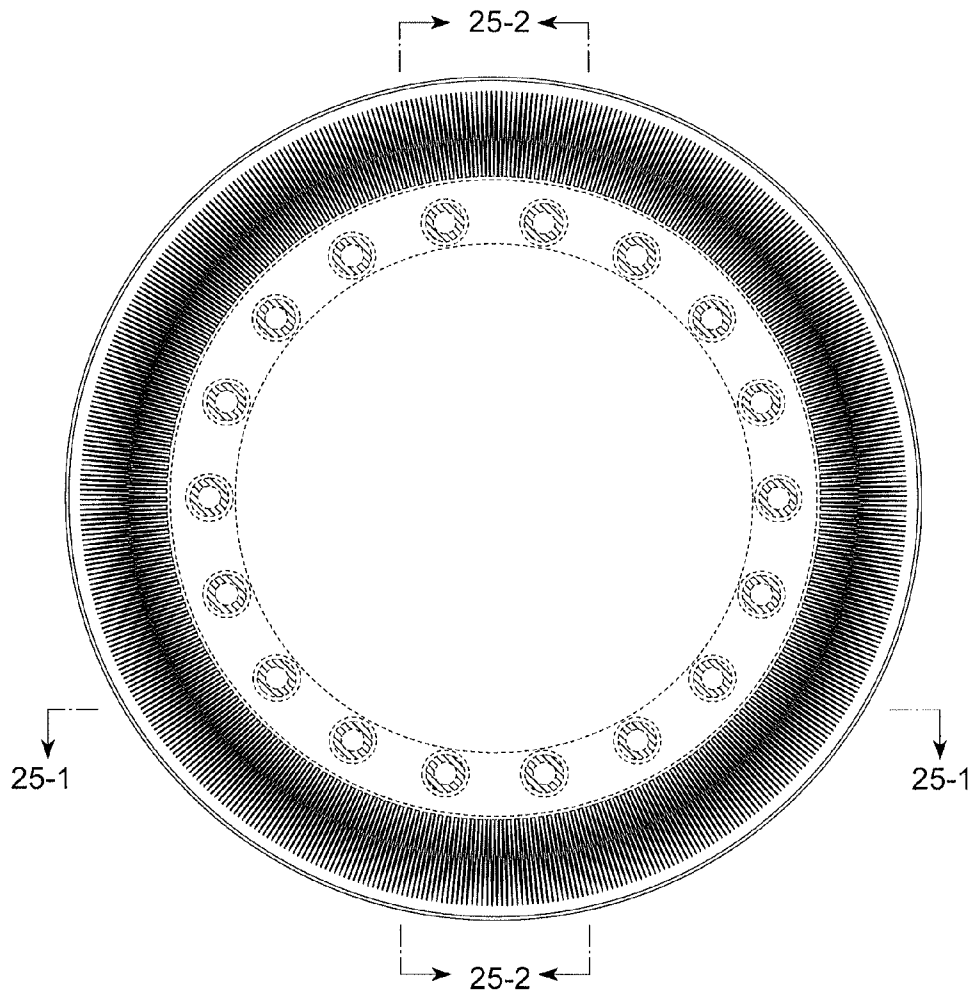

Fig.22

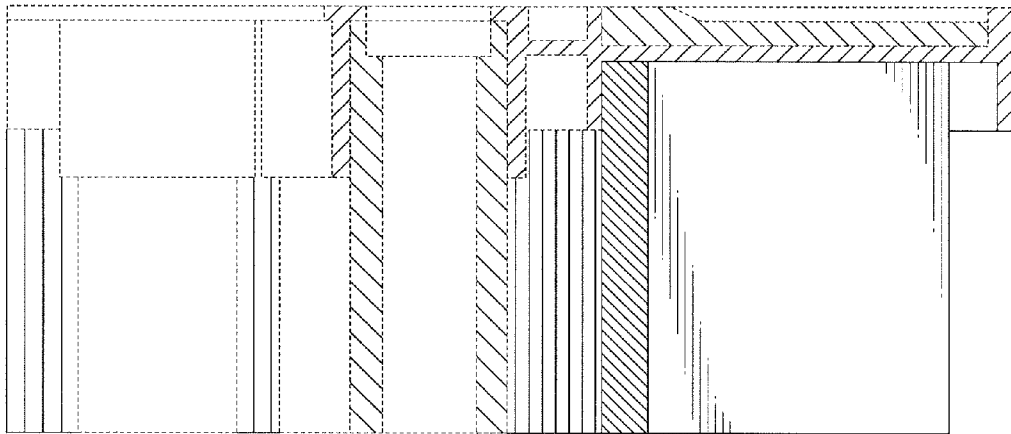

Fig.23

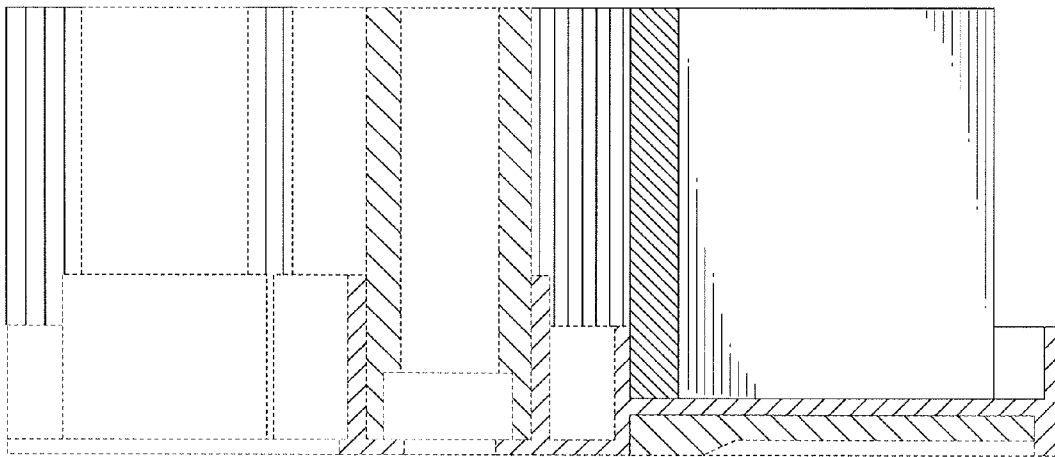

Fig.24

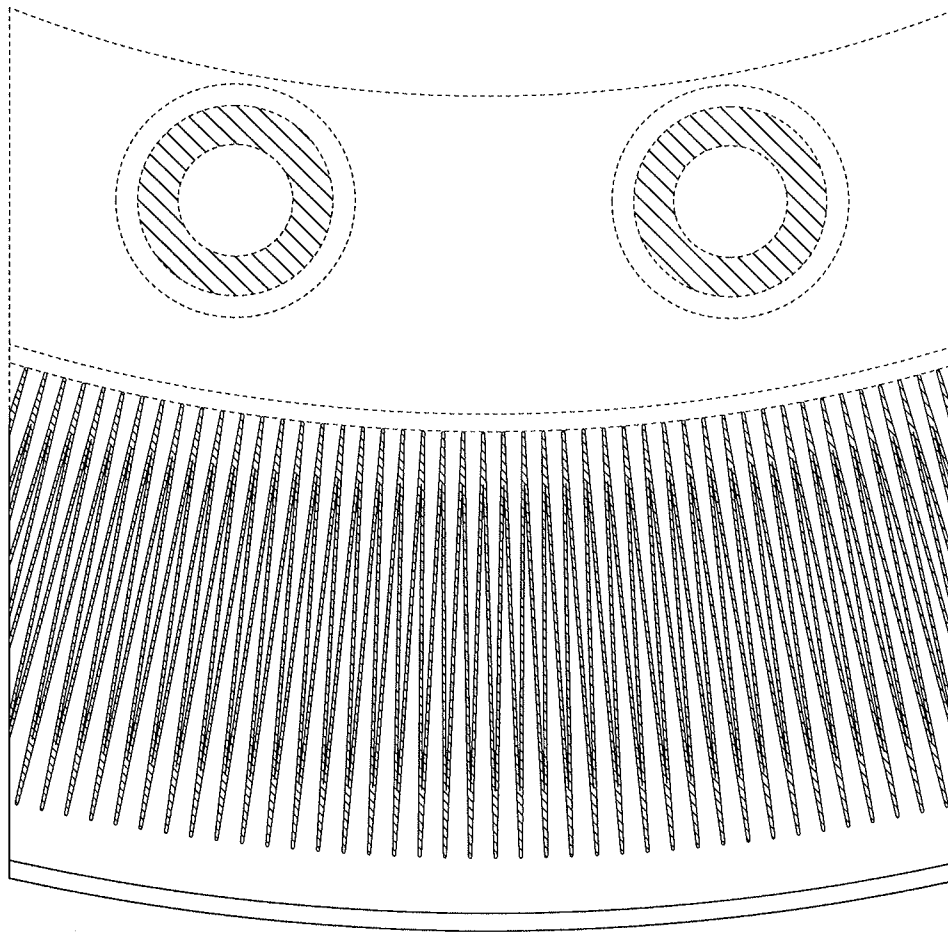

Fig.25

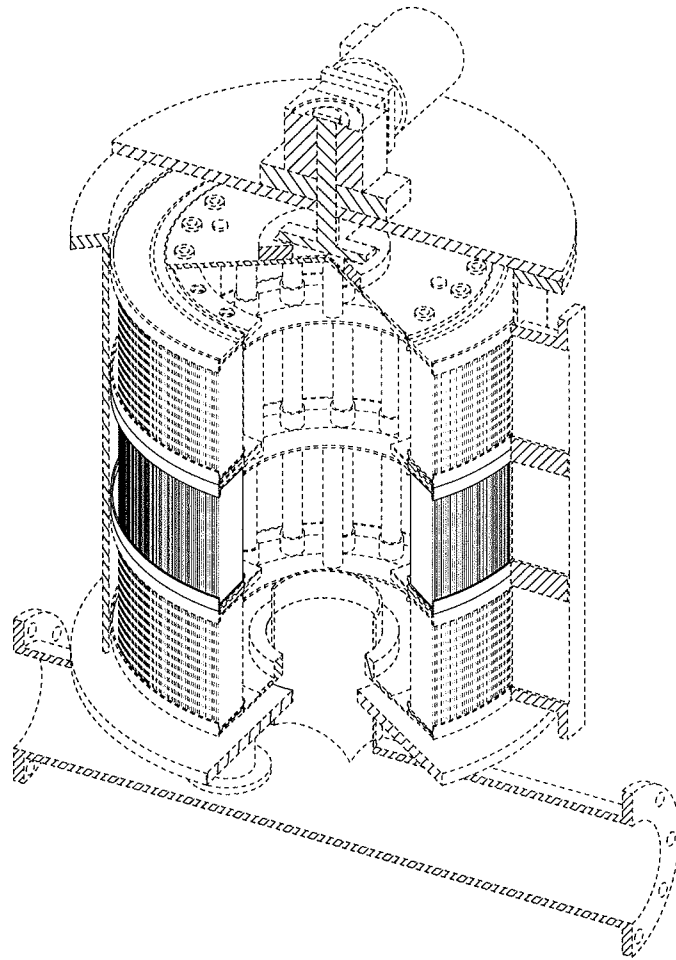

Fig.26