



- (51) International Patent Classification: **H04B 1/40** (2006.01)
- (21) International Application Number: PCT/US2013/037610
- (22) International Filing Date: 22 April 2013 (22.04.2013)
- (25) Filing Language: English
- (26) Publication Language: English
- (30) Priority Data: 61/637,788 24 April 2012 (24.04.2012) US
- (71) Applicant: **ZTE (USA) INC.** [US/US]; 2425 N. Central Expressway, Suite 600, Richardson, TX 75080 (US).
- (72) Inventors: **SHEN, Ying**; 100 River Birch Lane, Chapel Hill, NC 27514 (US). **NEALIS, Edwin**; 129 Trailing Oak, Cary, NC 27513 (US). **SEMENYSHEV, Aleksandr**; 3003 Commodore Drive, Apex, NC 27502 (US). **SCHMID, William**; 104 Olvera Way, Holly Spring, NC 27540 (US). **WALSH, Shawn**; 130 Park Crest Drive, Cary, NC 27519 (US). **NGUYEN, Thanh**; 202 Edgemore Avenue, Cary, NC 27519 (US). **KOCHETKOV, Andrey**; 310 Minton Valley Lane, Cary, NC 27519 (US). **YOM, Dong, Hong**; 139 Presidents Walk Lane, Cary, NC 27519 (US).
- (74) Agents: **SUN, Yalei** et al.; Morgan Lewis & Bockius LLP, 2 Palo Alto Square, 3000 El Camino Real, Suite 700, Palo Alto, CA 94306 (US).
- (81) Designated States (unless otherwise indicated, for every kind of national protection available): AE, AG, AL, AM, AO, AT, AU, AZ, BA, BB, BG, BH, BN, BR, BW, BY, BZ, CA, CH, CL, CN, CO, CR, CU, CZ, DE, DK, DM, DO, DZ, EC, EE, EG, ES, FI, GB, GD, GE, GH, GM, GT, HN, HR, HU, ID, IL, IN, IS, JP, KE, KG, KM, KN, KP, KR, KZ, LA, LC, LK, LR, LS, LT, LU, LY, MA, MD, ME, MG, MK, MN, MW, MX, MY, MZ, NA, NG, NI, NO, NZ, OM, PA, PE, PG, PH, PL, PT, QA, RO, RS, RU, RW, SC, SD, SE, SG, SK, SL, SM, ST, SV, SY, TH, TJ, TM, TN, TR, TT, TZ, UA, UG, US, UZ, VC, VN, ZA, ZM, ZW.
- (84) Designated States (unless otherwise indicated, for every kind of regional protection available): ARIPO (BW, GH, GM, KE, LR, LS, MW, MZ, NA, RW, SD, SL, SZ, TZ, UG, ZM, ZW), Eurasian (AM, AZ, BY, KG, KZ, RU, TJ, TM), European (AL, AT, BE, BG, CH, CY, CZ, DE, DK, EE, ES, FI, FR, GB, GR, HR, HU, IE, IS, IT, LT, LU, LV, MC, MK, MT, NL, NO, PL, PT, RO, RS, SE, SI, SK, SM, TR), OAPI (BF, BJ, CF, CG, CI, CM, GA, GN, GQ, GW, ML, MR, NE, SN, TD, TG).

Published:
— with international search report (Art. 21(3))

(54) Title: FLEXIBLE UNIFIED ARCHITECTURE FOR POINT-TO-POINT DIGITAL MICROWAVE RADIOS

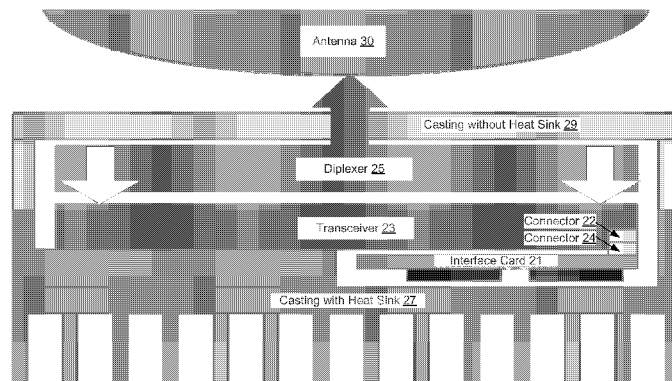

FIG. 5

(57) Abstract: A transceiver used in a radio unit for wireless communication, comprises: a circuitry board including a transmitter and a receiver; a first connector on a first side of the circuitry board, wherein the first connector is configured to be connected to an interface card; a second connector on a second side of the circuitry board, wherein the second side is opposite the first side and the second connector is configured to be connected to a digital card via a flexible circuit; and a pair of transmit port and receive port located on the second side of the circuitry board, wherein the transmit port is coupled to the transmitter and the receive port coupled to the receiver, respectively. When the transceiver is part of a split-mount radio unit (SRU), the first connector is connected to the interface card and the second connector is not in use. When the transceiver is part of an all-outdoor radio unit (AOU), the second connector is connected to the digital card and the first connector is not in use.

WO 2013/163093 A1

Flexible Unified Architecture for Point-to-Point Digital Microwave Radios

TECHNICAL FIELD

[0001] The presented invention relates to wireless communications and, in particular, to a flexible unified architecture for point-to-point digital microwave radios.

BACKGROUND

[0002] The fourth-generation (4G) wireless networks represent the next wave of mobile multimedia networks currently in development and the 4G Long Term Evolution (LTE) mobile networks are becoming a reality. Among others, the backhaul point-to-point microwave radios is a key part of this whole 4G network and plays an important role to the network success.

[0003] Point-to-Point Microwave Radios have a very wide range of frequency bands, typical licensed bands include 6GHz, 7GHz, 8GHz, 10GHz, 11GHz, 13GHz, 15GHz, 18GHz, 23GHz, 26GHz, 28GHz, 32GHz, 38GHz and 42GHz, plus unlicensed bands at sub 6GHz, 60GHz and the latest light license band of E-band (71-86GHz). The covered modulations include QPSK, 16QAM, 32QAM, 64QAM, 128QAM, 256QAM and extends to latest 512QAM and 1024QAM, and future even higher modulation such as 2048QAM and 4096QAM. The covered bandwidth includes popular international bandwidth of 3.5MHz/7MHz/14MHz/28MHz/56MHz and North America's FCC bands of 5MHz/10MHz/20MHz/30MHz/40MHz/50MHz and coming new 112MHz, 250MHz and 500MHz channel bandwidths.

[0004] In order to support these different radio configurations, frequency bands, modulations, capacity offerings, it is becoming more and more important to develop a point-to-point microwave radio with common mechanics, common interface to antenna, common software, and common automatic test equipment (ATE) for achieving such goals as low cost of deployment and maintenance and short time to market, etc. Moreover, both the operators and equipment vendors/manufacturers also prefer that their microwave equipment complies with a flexible unified architecture that supports various platforms, which is scalable, interchangeable, and shares common elements for all capacities and frequency bands.

SUMMARY

[0005] According to some implementations, a transceiver used in a radio unit for wireless communication comprises: a circuitry board including a transmitter and a receiver; a first connector on a first side of the circuitry board, wherein the first connector is configured to be connected to an interface card; a second connector on a second side of the circuitry board, wherein the second side is opposite the first side and the second connector is configured to be connected to a digital card via a flexible circuit; and a pair of transmit port and receive port located on the second side of the circuitry board, wherein the transmit port is coupled to the transmitter and the receive port coupled to the receiver, respectively.

[0006] According to some implementations, a split-mount radio unit comprises an indoor unit and an outdoor unit that is connected to the indoor unit via a cable. The outdoor unit further includes: an enclosure including a pair of first and second castings, wherein the first casting includes a heat sink; an interface card mounted on an inside surface of the first casting, wherein the interface card includes a connector on a surface opposite the inside surface of the first casting; a transceiver mounted on the inside surface of the first casting, wherein the transceiver includes a first connector on a first side of the transceiver facing the inside surface of the first casting and a second connector and a pair of transmit port and receive port on a second side opposite the first side of the transceiver, the first connector is connected to the connector of the interface card and the second connector is not in use; a diplexer including a pair of transmit port and receive port on a surface facing the second side of the transceiver and a common port on an opposite surface facing an inside surface of the second casting, wherein the pair of transmit port and receive port of the diplexer are connected to the corresponding pair of transmit port and receive port of the transceiver; and an antenna outside the enclosure, wherein the antenna includes a port connected to the common port of the diplexer through a hole of the second casting.

[0007] According to some implementations, an all-outdoor radio unit comprises: an enclosure including a pair of first and second castings, wherein each of the pair of first and second castings includes a heat sink; a transceiver mounted on an inside surface of the first casting, wherein the transceiver includes a first connector on a first side of the transceiver facing the inside surface of the first casting and a second connector and a pair of transmit port and receive port on a second side opposite the first side of the transceiver; a diplexer including a pair of transmit port and receive port on a first side of the diplexer facing the inside surface of the first casting and a common port on an opposite side of the diplexer

facing an inside surface of the second casting, wherein the pair of transmit port and receive port of the diplexer are connected to the corresponding pair of transmit port and receive port of the transceiver; a digital card mounted on the inside surface of the second casting, wherein the digital card includes a hole near its center and a connector on a surface opposite the inside surface of the second casting for connecting to the second connector of the transceiver via a flexible circuit; and an antenna outside the enclosure, wherein the antenna includes a port connected to the common port of the diplexer via a waveguide connection through a hole of the second casting and the hole near the center of the digital card, respectively.

BRIEF DESCRIPTION OF THE DRAWINGS

[0008] Different aspects of the present invention as well as features and advantages thereof will be more clearly understood hereinafter as a result of a detailed description of implementations of the present invention when taken in conjunction with the accompanying drawings, which are not necessarily drawn to scale. Like reference numerals refer to corresponding parts throughout the several views of the drawings.

[0009] FIG. 1 depicts a block diagram of a typical split-mount radio unit (SRU).

[0010] FIG. 2 depicts a block diagram of a typical all-outdoor radio unit (AOU).

[0011] FIG. 3 depicts a more detailed block diagram of the SRU according to some implementations of the present invention.

[0012] FIG. 4 depicts a more detailed block diagram of the AOU according to some implementations of the present invention.

[0013] FIG. 5 depicts a simplified cross-sectional view of the SRU according to some implementations of the present invention.

[0014] FIG. 6 depicts a simplified exploded view of the SRU according to some implementations of the present invention.

[0015] FIG. 7 depicts a simplified cross-sectional view of the AOU according to some implementations of the present invention.

[0016] FIG. 8 depicts a simplified exploded view of the AOU according to some implementations of the present invention.

[0017] FIG. 9 depicts the top and bottom of a transceiver and the position of the connector for use in the SRU and AOU according to some implementations of the present invention.

[0018] FIG. 10 depicts a block diagram of RF components control software according to some implementations of the present invention.

[0019] FIG. 11 depicts a block diagram illustrating a process of the RF components control software tuning with different bandwidth/modulation profiles for different system configurations according to some implementations of the present invention.

[0020] FIG. 12 depicts a flow chart illustrating a testing and integration workflow for both the SRU and the AOU according to some implementations of the present invention.

DESCRIPTION OF EMBODIMENTS

[0021] Reference will now be made in detail to implementations, examples of which are illustrated in the accompanying drawings. In the following detailed description, numerous non-limiting specific details are set forth in order to assist in understanding the subject matter presented herein. It will be apparent, however, to one of ordinary skill in the art that various alternatives may be used without departing from the scope of the present invention and the subject matter may be practiced without these specific details.

[0022] The point-to-point microwave radios in its path transition from all indoor radios, to split mount radios and now to all outdoor radios. In the past, most radios used in Point to Point microwave wireless were comprised of radio units that were mounted indoors. These radios hardware platforms required radios that were rack mounted indoors and had to use large coax or Elliptical Waveguide running out from the indoor radio unit up the tower (or to the roof top), connecting the antenna. The industry later came out with a split-mount design radio system consisting of an indoor modem unit "IDU" and an outdoor RF Unit "ODU" that mounts the actual radio RF component hardware directly onto the back of the antenna. Today the industry has migrated to All Outdoor radio Unit systems "AOU" comprised of a single outdoor unit mounted to the back of the antenna. These AOU's contain the RF components, modems, and network interface. The connection between the AOU and the network switch is typically outdoor shielded twisted pair (CAT-5e) or fiber. The AOU design has far greater advantages over the indoor radio or IDU+ODU spit mount designs.

[0023] FIG. 1 depicts a block diagram of a conventional split-mount radio unit (SRU), including three basic parts: an indoor unit 10 (IDU), an outdoor unit 20 (ODU) and an antenna 30. IDU 10 is typically composed of a modem, various mux circuitries, a controller, a power module and various line interfaces. The connection between IDU 10 and ODU 20 is through a cable such as an RG-8 cable of a length ranging from a few feet up to 1000 feet. ODU 20 includes a cable mux circuitry, which splits a signal into a transmitter IF signal, a receiver IF signal, telemetry and DC signals. An up-converter converts the transmitter IF signal into a small RF signal; a power amplifier then amplifies the small RF signal to a larger RF signal. A waveguide diplexer 25 then transmits the RF signal to the antenna 30. On the receiver side, the antenna 30 receives a RF signal and transmits the RF signal through a low noise amplifier and a down-converter into a receiver IF signal. The receiver IF signal then arrives at IDU 10 through the cable mux circuitry for further signal process. IDU 10 has various customer interfaces, network process/management access, battery DC connection, and standard IP and TDM access ports.

[0024] FIG. 2 depicts a block diagram of a typical all-outdoor radio unit 40 (AOU). AOU 40 integrates modem, mux, controller into one unit. Since AOU 40 is an outdoor unit, it supports a standard IP Ethernet interface with power over Ethernet (POE) feature and supports optional fiber interface. AOU 40 also has an RSSI port for antenna alignment purpose.

[0025] An effective design for both SRU and AOU becomes a challenge for all radio equipment vendors. This invention discloses many ideas for both product families, SRU and AOU, so as to share design, hardware, software, calibration, test flow, test stations, antenna interface, and mounting mechanics etc., and reduce the design, manufacturing and time to market cycles.

[0026] FIG. 3 depicts a more detailed block diagram of the SRU according to some implementations of the present invention. In some implementations, the radio unit includes three basic modules: a diplexer 25, a transceiver 23 and an interface card 21. As shown in FIG. 4, the SRU and the AOU share the same transceiver and diplexer. The only change in the AOU is to change the interface card 21 to a digital card 41.

[0027] Note that the transceiver, as a key module for both product families (SRU and AOU), has the following features:

- a. Transceiver supports both I/Q and Tx IF interfaces. In the AOU, the transceiver uses I and Q signals. In the SRU, the transceiver uses Tx IF signal.
- b. Transceiver has a total of three detectors in the transmitter chain, D1, D2 and D3. D1 is used for automatic gain control for cable compensation in the SRU application and it is not in the AOU application. D2 is used as an envelope detection for auto signal quality adaptive adjustment in the AOU application and as an additional signal detection in the SRU application. D3 uses mixing down feature for power amplifier (PA) detection and alarm purposes in both applications.
- c. Transceiver supports both open loop digital pre-distortion (DPD) and analog adaptive pre-distortion (APD) feature. All the filters in the transmitter chain have 2.5 time wider bandwidth than the signal bandwidth to support open loop DPD. The parameters needed for open loop DPD are characterized through calibration, then applies the polynomial parameters to the modem look up table (LUT) to correct and improve the non-linearity from the PA. APD is achieved through two couplers, P1, P2 and a coupled down converted signal after the PA, in the transmitter chain, to a customized IC to achieve the improvement for the non-linearity from the PA.
- d. The PA has the bias setting control capability to support reduced bias during low power level to support general "Green" application.
- e. On the receiver side, the receiver signal level (RSL) chain uses a mixing mechanism and converter RF signal to the same Rx IF as the main signal, then uses a narrow band filter to reject interference signal to have a better signal indication accuracy.
- f. The transceiver supports RF loopback capabilities. The loopback chain includes three couplers, two RF pads and a diode voltage controlled switch. When loopback command is off, the diode switch is in high attenuation mode, and when the loopback command is on, diode switch attenuation will be from high to low. RF loopback provides the radio to having a self-diagnosis capability.
- g. Transceiver supports on-board local reference or a reference from digital board or from the IDU for future hitless and coherent applications.

[0028] In some implementations, a common transceiver is used for SRU and AOU.

[0029] FIG. 5 depicts a simplified cross-sectional view of the SRU according to some implementations of the present invention. The transceiver 23 is mounted to a casting 27 for

heat sinking. The interface card 21 is mounted to the same casting 27 as the transceiver 23. The transceiver 23 and the interface card 21 are connected through a pair of mating connectors 22 and 24. One connector 24 of the pair is installed on the top of the interface card 21 and the other connector 24 is installed on the bottom of the transceiver 23. Further detail can be seen in FIG. 6 that is an exploded view of the SRU shown in FIG. 5.

[0030] FIG. 7 depicts a simplified cross-sectional view of the AOU according to some implementations of the present invention. The transceiver 43 is mounted to a casting 47 for heat sinking as in the SRU. In the AOU, the digital card 41 is mounted to its own casting 49 for heat sinking. Since the digital card 41 is larger than the interface card 21 and generates much more heat, it cannot be mounted to the same casting as the transceiver 43. To simplify the connection between the transceiver 43 and the digital card 41, the connector 44 on the transceiver 43 is relocated from the bottom of the transceiver 43 to the top of the transceiver 43. There is a dual footprint for the connector 44 with one footprint on the bottom to be utilized when the transceiver 43 is installed in an SRU and with one footprint on the top to be utilized when the transceiver 43 is installed in an AOU. A flexible circuit 46 (represented by the white double-sided arrow) is used in the AOU to bridge the gap between the connectors 42 and 44 of the digital card 41 and the transceiver 43. By relocating the connector, a common transceiver is used for the SRU and AOU. Further detail can be seen in FIG. 8, which is an exploded view of the AOU.

[0031] FIG. 9 depicts the top and bottom of a transceiver and the position of the connector for use in the SRU and AOU according to some implementations of the present invention. In some implementations, the present invention proposes a common diplexer for the SRU and AOU.

[0032] The common diplexer 25/45 can be seen in FIGS. 5 and 7. The transmit port and the receive port of the diplexer 25/45 connect to the transmit port and receive port of the transceiver 23/43. Since the transceiver and diplexer are both common to the SRU and AOU, the connection between the two is also common. In the SRU, the diplexer common port extends out of a hole in the SRU enclosure and connects to the antenna. For the AOU, the diplexer common port is not long enough to extend out of a hole in the AOU enclosure casting due to the location of the digital card between the diplexer and the casting and also due to the addition of cooling fins to this casting. In order to utilize a common diplexer a Waveguide Extension is added. This extension is a passive component that bridges the distance between the diplexer and the antenna. Further detail can be seen in Figures 6 and 8.

[0033] In some implementations, the present invention proposes a common antenna interface and a common mounting mechanics for the SRU and AOU.

[0034] The common antenna 30 can be seen in FIGS. 5 and 7. The common port of the diplexer connects to the antenna to pass the transmit and the receive signals between the antenna and the SRU and AOU. This connection is a waveguide connection. For the SRU, the antenna feed mates directly to the diplexer through the opening in the casting for the diplexer common port. For the AOU, the antenna feed mates to the waveguide extension which mates to the diplexer. Refer to Figures 6 and 8 for more detail. The SRU casting has four mounting posts that are used to mount the SRU to the antenna using screws. The AOU has four similar mounting posts that are in the same location relative to the antenna feed interface as on the SRU. This configuration allows the use of a common antenna interface and common mounting mechanics for the SRU and AOU.

[0035] In some implementations, the present invention proposes common software and common control for SRU and AOU

[0036] FIG. 10 depicts a block diagram of RF components control software according to some implementations of the present invention. The RF components control software controls RF Hardware and provides generic interface for system configuration. Software design includes following key points:

- a. Design isolates Application Modules from Operation System by using OS Abstract Layer as shown in FIG. 10, so RF Components Control Software can use different Operation Systems as a base in case of AOU and SRU. It is usually required since complexity of AOU and IDU software is different.
- b. Adapter module implements generic interface for communication with IDU via telemetry channel in case of ODU or with other modules outside RF Components Control Software in case of AOU via inter-task communication mechanism.
- c. All bandwidth and modulation dependant data like, maximum power level, attenuation ranges for attenuators, correction factors for detectors reading, etc. are stored separately from RF Components Control Software in form of Bandwidth/Modulation Profiles. Profiles can be updated separately from the software that simplifies software development and maintenance. For better system resources utilization, dedicated Parameter module loads only one particular profile for current configuration as shown on FIG. 11. Each frequency band has its own set of

Bandwidth/Modulation Profiles, so as soon as new band hardware design follows common system architecture, only new set of Bandwidth/Modulation Profiles needs to be introduced to make software support new hardware. No changes in RF Components Control Software are required.

[0037] In some implementations, the present invention proposes a common calibration routine, common Automatic Test Equipment (ATE) and common test flow for both SRU and AOU. FIG. 12 depicts a flow chart illustrating a testing and integration workflow for both the SRU and the AOU according to some implementations of the present invention. SRU includes four basic parts, diplexer, transceiver (TRX), interface card and SRU mechanics. Diplexer, TRX and INFC first go through module own pass/fail test station, then TRX, INFC and SRU mechanics integrated together as a Radio Frequency Unit (RFU), RFU goes through RF and DPD calibration, then integrated with diplexer becomes a frequency band dependent part and go through final SRU test flow. AOU has the similar test flow, and sharing TRX and diplexer exactly with SRU.

[0038] ATE flow chart includes the following key ideas:

- a. TRX and Diplexer designed mechanically, electronically and tested for both SRU and AOU families
- b. TRX module test and calibration includes regular RF pass/fail test, RF calibration at room temperature, then applies correction factors for temperature range, which covers from -33°C to +55°C, frequency range, output power, 30dB dynamic range for Pout and 70dB dynamic range for the receiver, various BW, from 5Mhz up to 56MHz, and various modulation from QPSK up to 1024QAM.
- c. TRX module performs the open loop digital pre-distortion (DPD) calibration at room temperature, then applies correction factor for temperature range, various output power levels, various frequency, various bandwidth and various baud rates.
- d. TRX RF and DPD calibration data stored in the local EEprom, and data will be used during radio operation per radio setting and automatically adjusted per on board temperature sensor, frequency, power level, bandwidth and capacity.

[0039] Compared with traditional SRU and AOU architecture, the flexible and unified radio architecture design of the present application has the following key advantages:

- a. Within the SRU family, the common interface card is used for all frequency bands. The typical license band includes frequency band of 6GHz, 7GHz, 8GHz, 10GHz, 11GHz, 13GHz, 15GHz, 18GHz, 23GHz, 26GHz, 28GHz, 32GHz, 38GHz and 42GHz.
- b. Within the AOU family, the common digital card is used for all frequency bands. The same frequency bands apply to SRU.
- c. The common diplexer is used for both SRU and AOU platforms.
- d. The common transceiver is used for both SRU and AOU platforms.
- e. The common software is used within the SRU platform and the AOU platform.
- f. The common software engine with different drivers between SRU and AOU platforms.
- g. The common mechanics is used within the SRU platform and the AOU platform.
- h. The common antenna interface is used for both the SRU and AOU platforms.
- i. The common mounting mechanism is used for both the SRU and AOU platforms.
- j. The common key TRX RF and DPD calibration routine is used for both the SRU and AOU platforms.
- k. The common test flow and integration flow is used for both the SRU and AOU platforms.
- l. Many unique features designed in transceivers including integrated APD/DPD, down converted high dynamic linear temperature compensated RF detection, integrated RF loopback, smart PA bias setting, and common reference for hitless and coherent features.

[0040] Overall, the architecture of the SRU and AOU is to enable the use of components and circuitry on the transceiver for both the SRU and AOU. This design conserves valuable area on the transceiver and allows the transceiver size to be minimized. Cost savings are also realized by reducing mechanical component sizes. The use of a common transceiver, diplexer, and antenna greatly reduces the number of unique components that must be designed, tested, and stocked. This reduction significantly reduces the time to market and design resources required. Economies of scale are realized in manufacturing since the volume of the common assemblies is increased.

[0041] In some implementations, the above-described methods and their variations may be implemented as computer software instructions or firmware instructions. Such instructions may be stored in an article with one or more machine-readable storage devices connected to one or more computers or integrated circuits or digital processors such as digital signal processors, microprocessors, or micro-control units (MCU), and the instructions may perform the transmission method for transmitting MTC data. In addition, the method may be applied to any MTC capable mobile communications device supporting the WCDMA technology and/or the LTE technology. Other variations and enhancements are possible based on what is mentioned here.

[0042] Although the terms first, second, etc. may be used herein to describe various elements, these elements should not be limited by these terms. These terms are only used to distinguish one element from another. The terminology used in the description of the invention herein is for the purpose of describing particular implementations only and is not intended to be limiting of the invention. As used in the description of the invention and the appended claims, the singular forms "a," "an," and "the" are intended to include the plural forms as well, unless the context clearly indicates otherwise. It will also be understood that the term "and/or" as used herein refers to and encompasses any and all possible combinations of one or more of the associated listed items. It will be further understood that the terms "includes," "including," "comprises," and/or "comprising," when used in this specification, specify the presence of stated features, operations, elements, and/or components, but do not preclude the presence or addition of one or more other features, operations, elements, components, and/or groups thereof.

[0043] As used herein, the term "if" may be construed to mean "when" or "upon" or "in response to determining" or "in accordance with a determination" or "in response to detecting," that a stated condition precedent is true, depending on the context. Similarly, the phrase "if it is determined [that a stated condition precedent is true]" or "if [a stated condition precedent is true]" or "when [a stated condition precedent is true]" may be construed to mean "upon determining" or "in response to determining" or "in accordance with a determination" or "upon detecting" or "in response to detecting" that the stated condition precedent is true, depending on the context.

[0044] Although some of the various drawings illustrate a number of logical stages in a particular order, stages that are not order dependent may be reordered and other stages may be combined or broken out. While some reordering or other groupings are specifically mentioned, others will be obvious to those of ordinary skill in the art and so do not present an exhaustive list of alternatives. Moreover, it should be recognized that the stages could be implemented in hardware, firmware, software or any combination thereof.

[0045] The foregoing description, for purpose of explanation, has been described with reference to specific implementations. However, the illustrative discussions above are not intended to be exhaustive or to limit the invention to the precise forms disclosed. Many modifications and variations are possible in view of the above teachings. The implementations were chosen and described in order to best explain principles of the invention and its practical applications, to thereby enable others skilled in the art to best utilize the invention and various implementations with various modifications as are suited to the particular use contemplated. Implementations include alternatives, modifications and equivalents that are within the spirit and scope of the appended claims. Numerous specific details are set forth in order to provide a thorough understanding of the subject matter presented herein. But it will be apparent to one of ordinary skill in the art that the subject matter may be practiced without these specific details. In other instances, well-known methods, procedures, components, and circuits have not been described in detail so as not to unnecessarily obscure aspects of the implementations.

We claim:

1. A transceiver used in a radio unit for wireless communication, comprising:
 - a circuitry board including a transmitter and a receiver;
 - a first connector on a first side of the circuitry board, wherein the first connector is configured to be connected to an interface card;
 - a second connector on a second side of the circuitry board, wherein the second side is opposite the first side and the second connector is configured to be connected to a digital card via a flexible circuit; and
 - a pair of transmit port and receive port located on the second side of the circuitry board, wherein the transmit port is coupled to the transmitter and the receive port coupled to the receiver, respectively.
2. The transceiver of claim 1, wherein, when the transceiver is part of a split-mount radio unit (SRU), the first connector is connected to the interface card and the second connector is not in use.
3. The transceiver of any of claims 1 to 2, wherein, when the transceiver is part of an all-outdoor radio unit (AOU), the second connector is connected to the digital card and the first connector is not in use.
4. The transceiver of any of claims 1 to 3, wherein the first connector and the second connector are configured not to be in use at the same time.
5. The transceiver of any of claims 1 to 4, wherein the first connector and the second connector have substantially mirror-imaged locations on the first and second sides of the circuitry board.
6. The transceiver of any of claims 1 to 5, wherein the pair of transmit port and receive port are configured to be connected to a pair of transmit port and receive port of a diplexer.
7. The transceiver of any of claims 1 to 6, wherein the transmitter further includes a plurality of detectors configured in a serial connection, circuitry supporting open loop digital pre-distortion and analog adaptive pre-distortion, and a power amplifier.
8. A split-mount radio unit, comprising:
 - an indoor unit; and

an outdoor unit that is connected to the indoor unit via a cable, wherein the outdoor unit further includes:

an enclosure including a pair of first and second castings, wherein the first casting includes a heat sink;

an interface card mounted on an inside surface of the first casting, wherein the interface card includes a connector on a surface opposite the inside surface of the first casting;

a transceiver mounted on the inside surface of the first casting, wherein the transceiver includes a first connector on a first side of the transceiver facing the inside surface of the first casting and a second connector and a pair of transmit port and receive port on a second side opposite the first side of the transceiver, the first connector is connected to the connector of the interface card and the second connector is not in use;

a diplexer including a pair of transmit port and receive port on a surface facing the second side of the transceiver and a common port on an opposite surface facing an inside surface of the second casting, wherein the pair of transmit port and receive port of the diplexer are connected to the corresponding pair of transmit port and receive port of the transceiver; and

an antenna outside the enclosure, wherein the antenna includes a port connected to the common port of the diplexer through a hole of the second casting.

9. The split-mount radio unit of claim 8, wherein the cable connecting the indoor unit and the outdoor unit is an RG-8 cable having a length ranging from a few feet up to 1000 feet.

10. The split-mount radio unit of any of claims 8 to 9, wherein the first connector and the second connector have substantially mirror-imaged locations on the first and second sides of the transceiver.

11. An all-outdoor radio unit, comprising:

an enclosure including a pair of first and second castings, wherein each of the pair of first and second castings includes a heat sink;

a transceiver mounted on an inside surface of the first casting, wherein the transceiver includes a first connector on a first side of the transceiver facing the inside surface of the first casting and a second connector and a pair of transmit port and receive port on a second side opposite the first side of the transceiver;

a diplexer including a pair of transmit port and receive port on a first side of the diplexer facing the inside surface of the first casting and a common port on an opposite side of the diplexer facing an inside surface of the second casting, wherein the pair of transmit port and receive port of the diplexer are connected to the corresponding pair of transmit port and receive port of the transceiver;

a digital card mounted on the inside surface of the second casting, wherein the digital card includes a hole near its center and a connector on a surface opposite the inside surface of the second casting for connecting to the second connector of the transceiver via a flexible circuit; and

an antenna outside the enclosure, wherein the antenna includes a port connected to the common port of the diplexer via a waveguide connection through a hole of the second casting and the hole near the center of the digital card, respectively.

12. The all-outdoor radio unit of claim 11, wherein the first connector and the second connector have substantially mirror-imaged locations on the first and second sides of the transceiver, respectively.

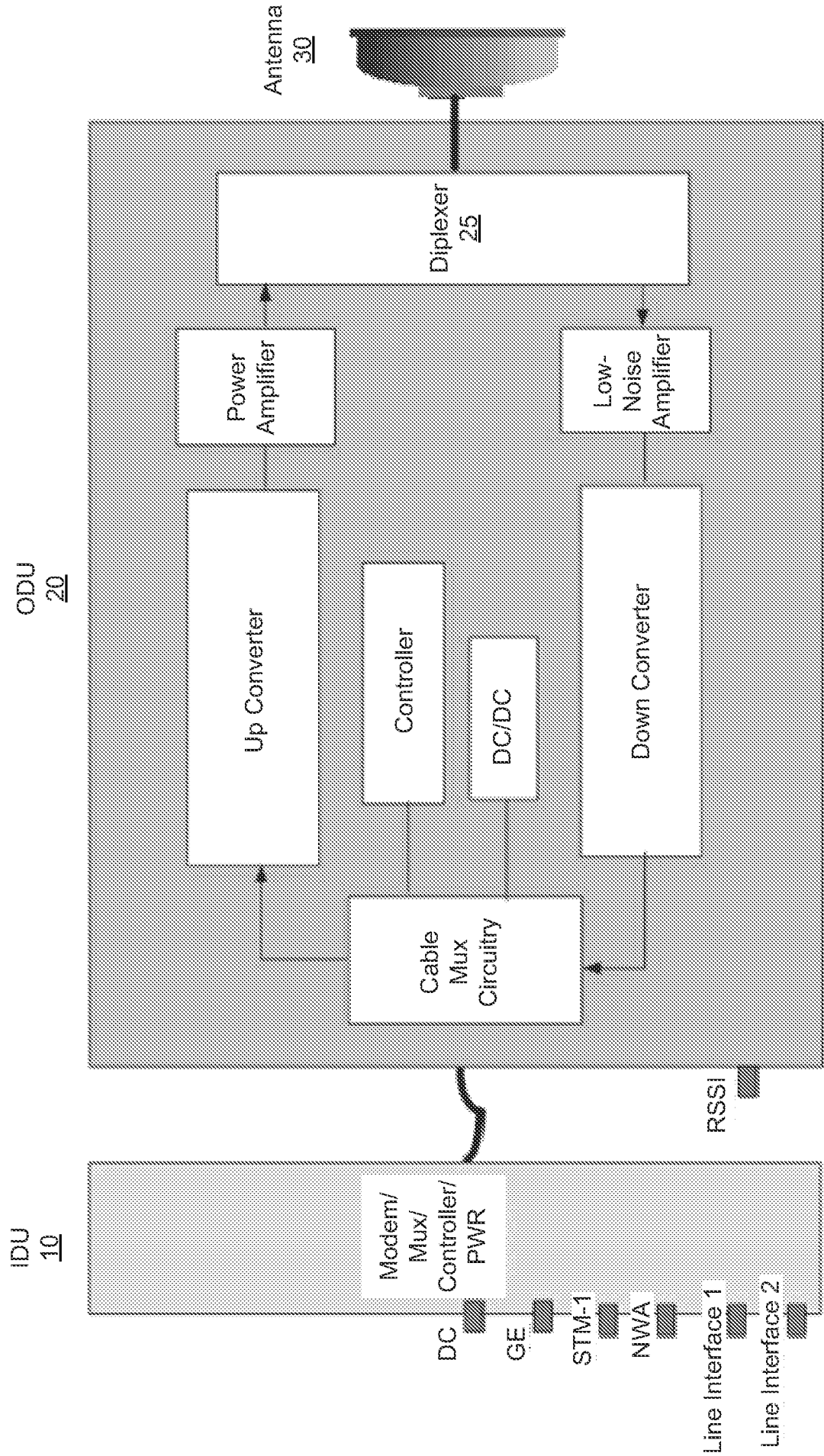

FIG. 1

AOU
40

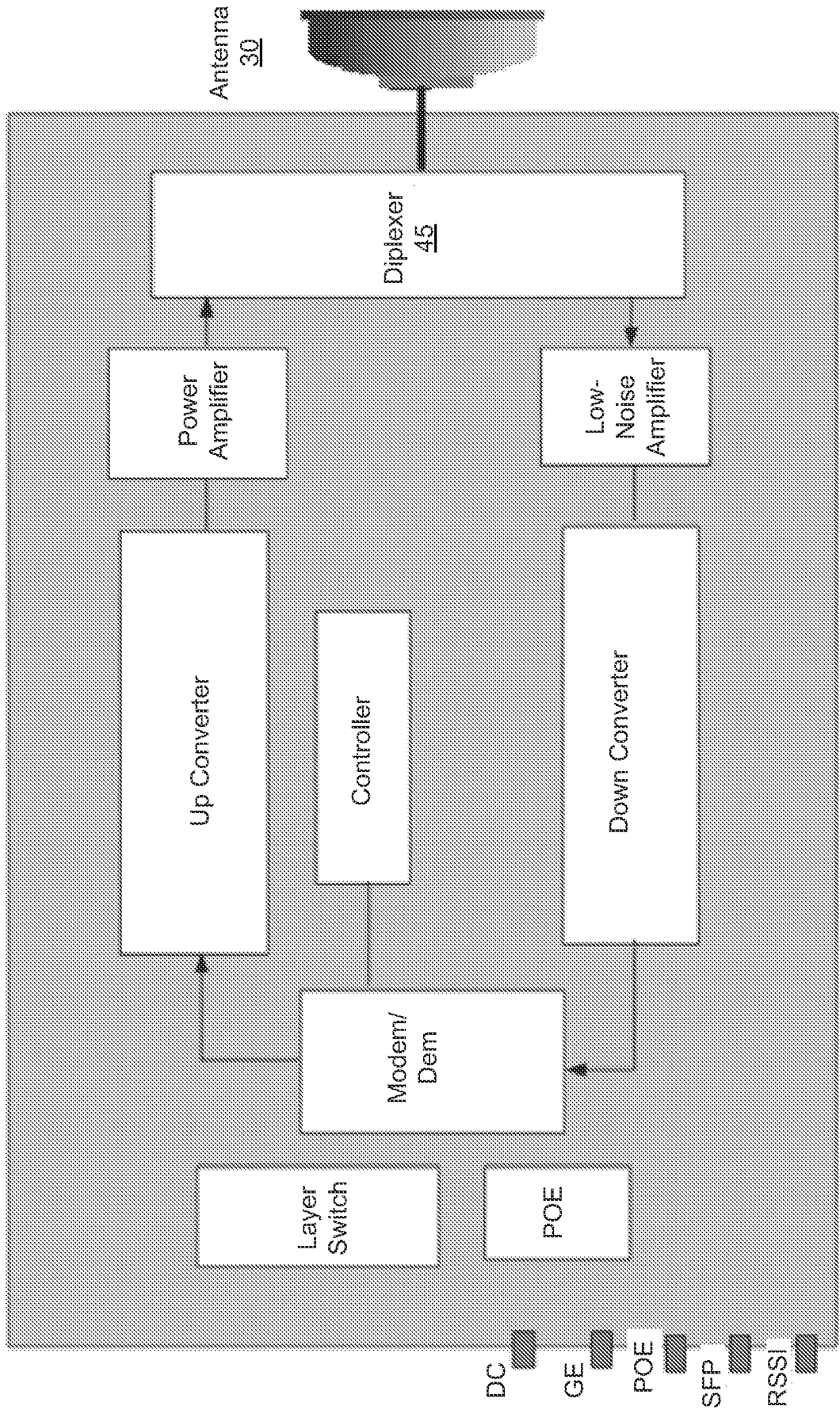

FIG. 2

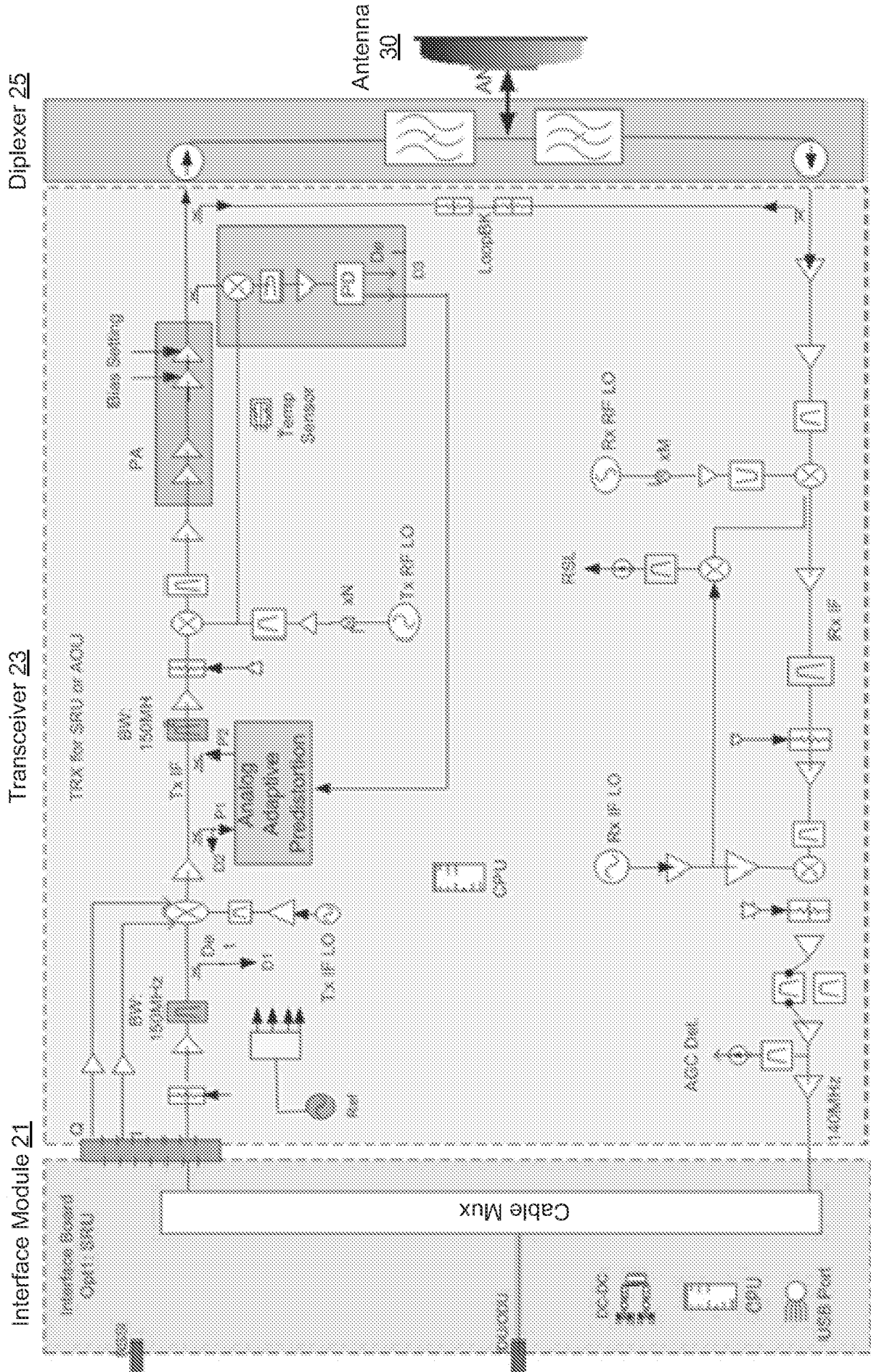

FIG. 3

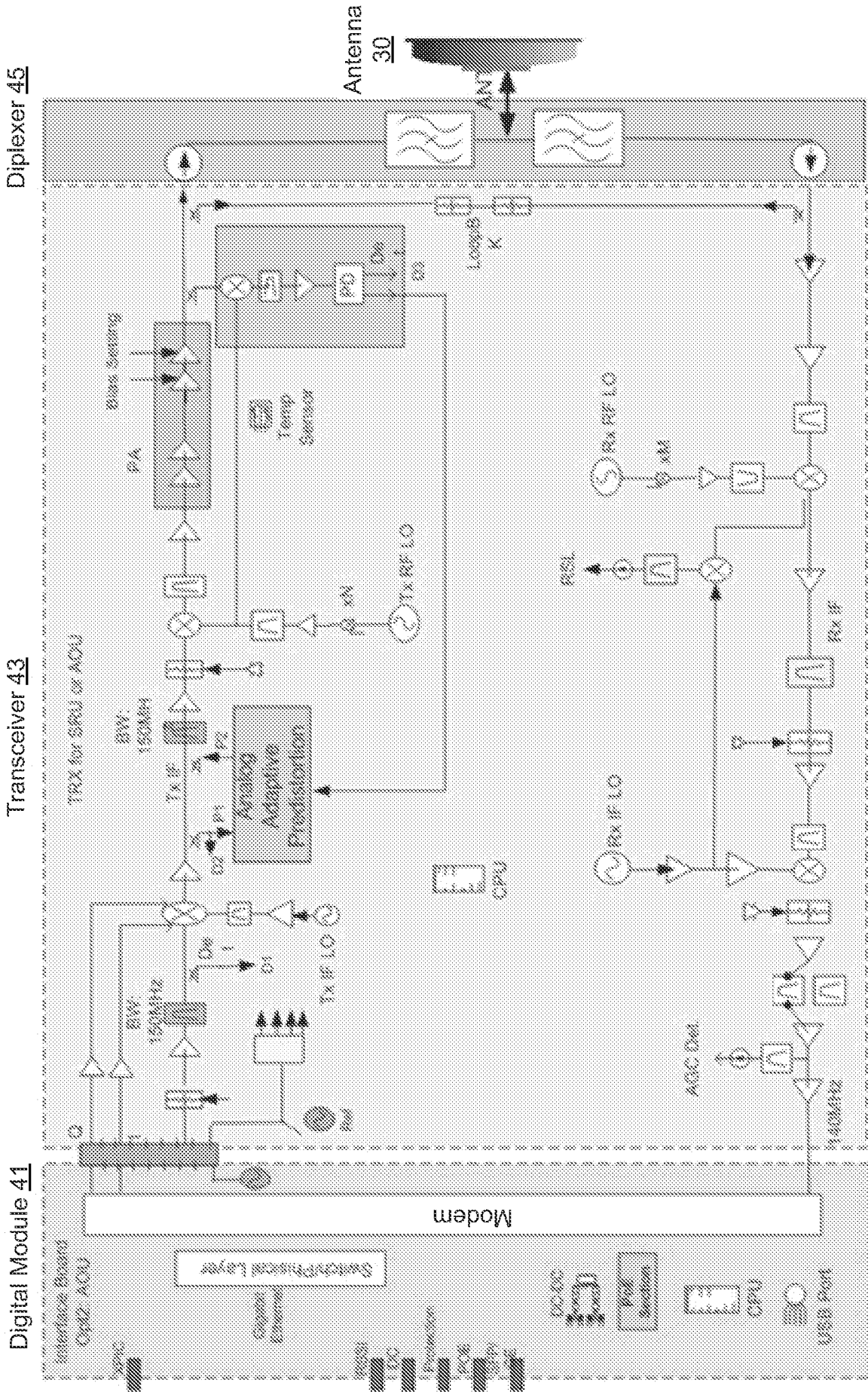

FIG. 4

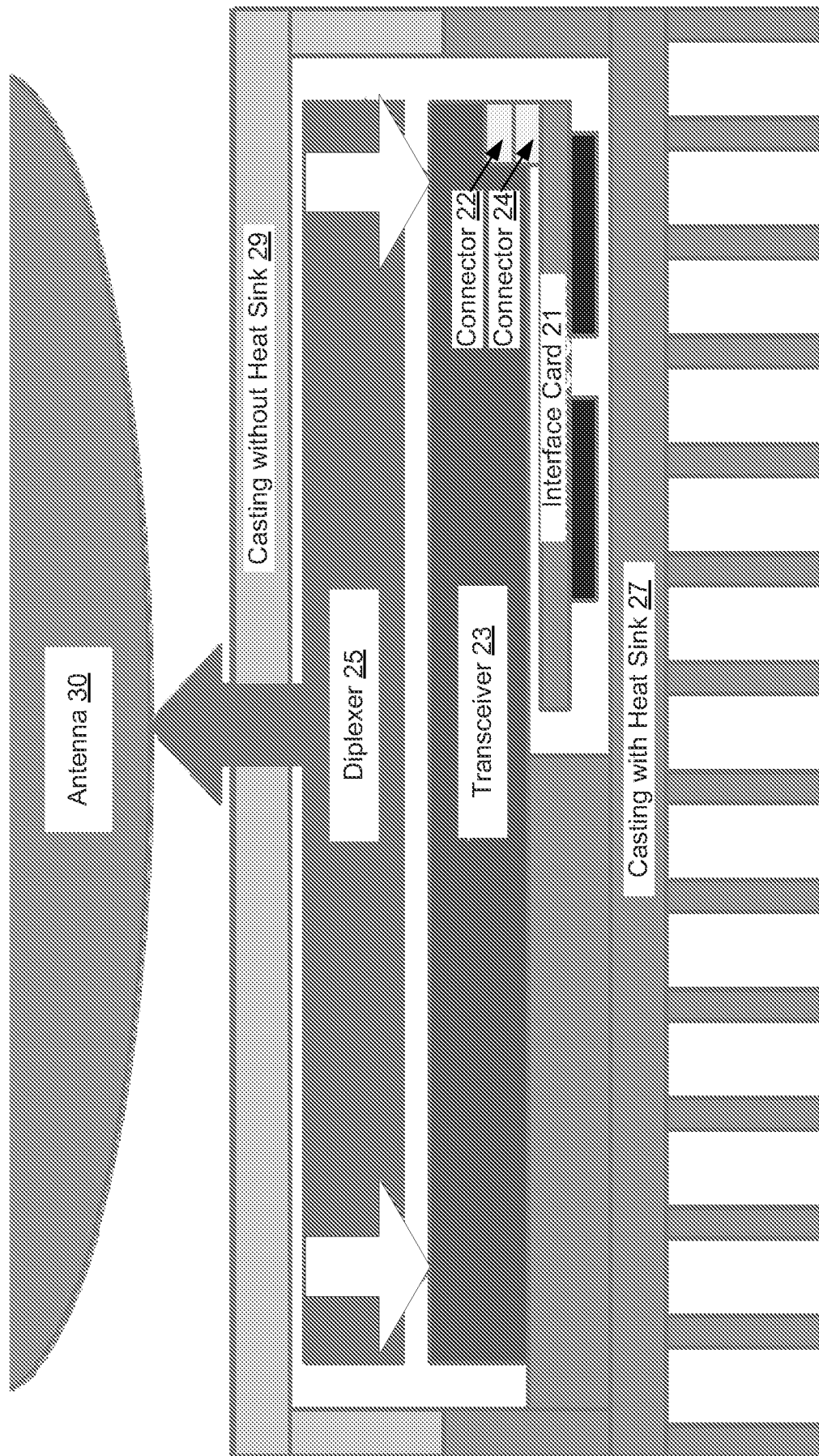

FIG. 5

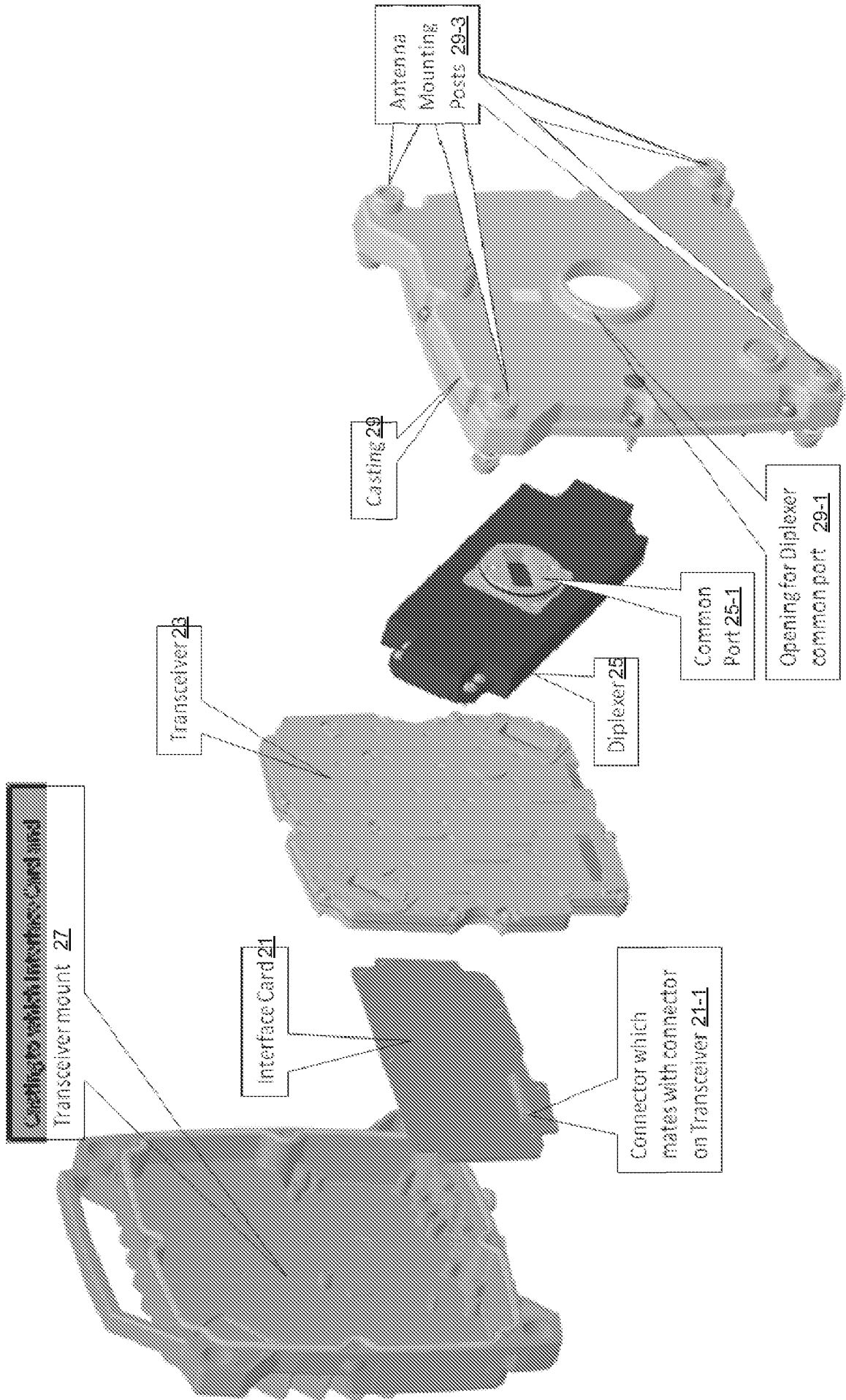

FIG. 6

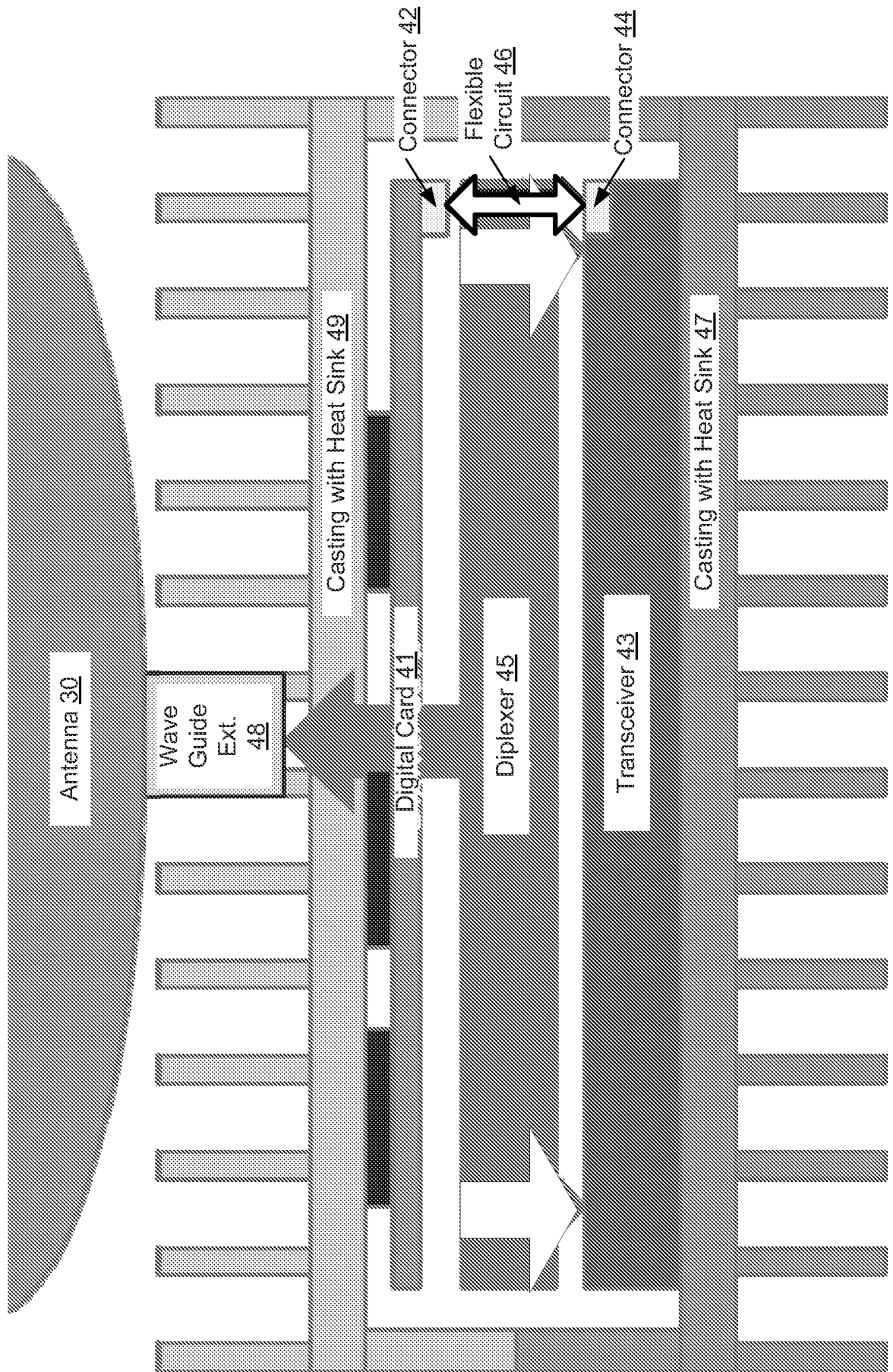

FIG. 7

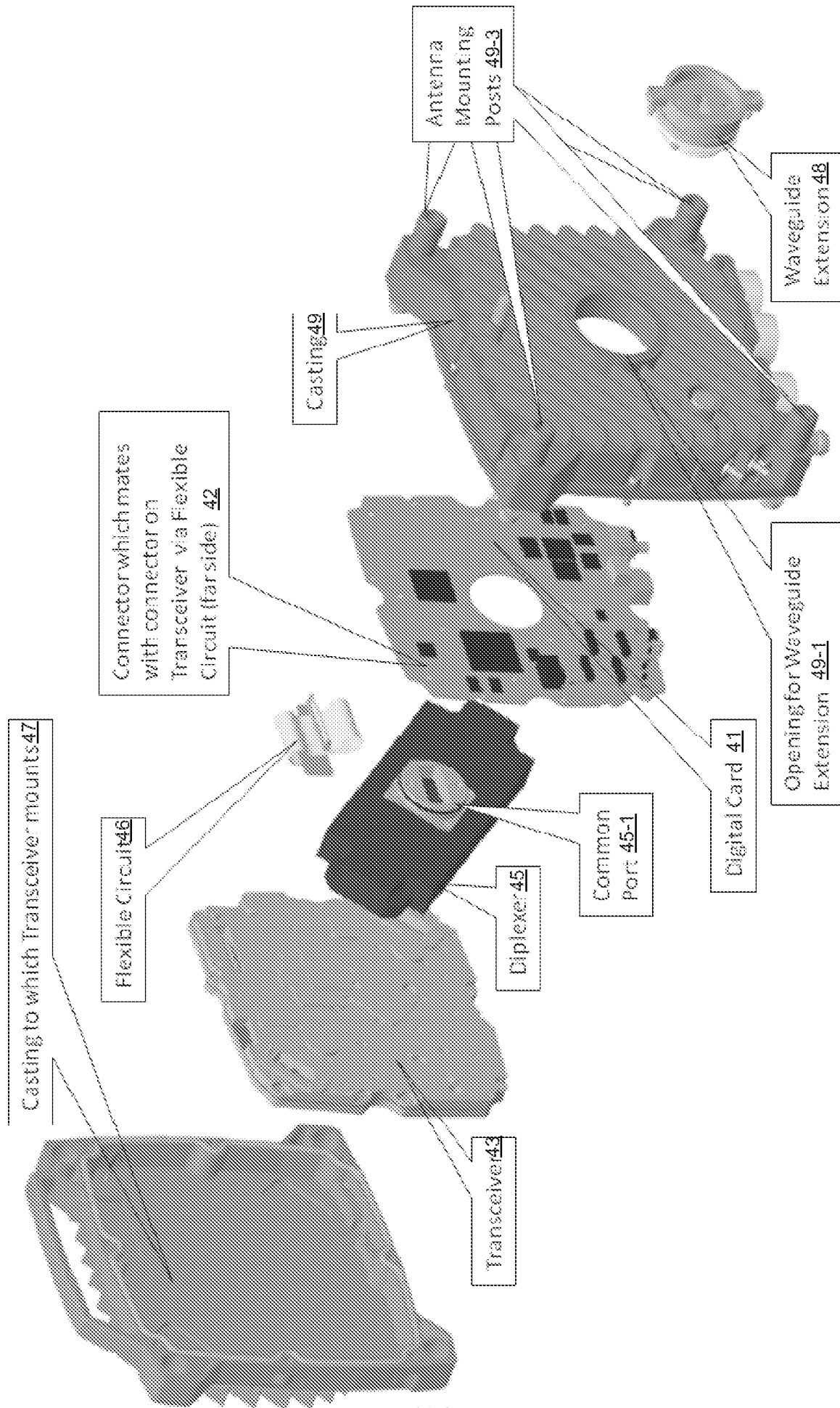

FIG. 8

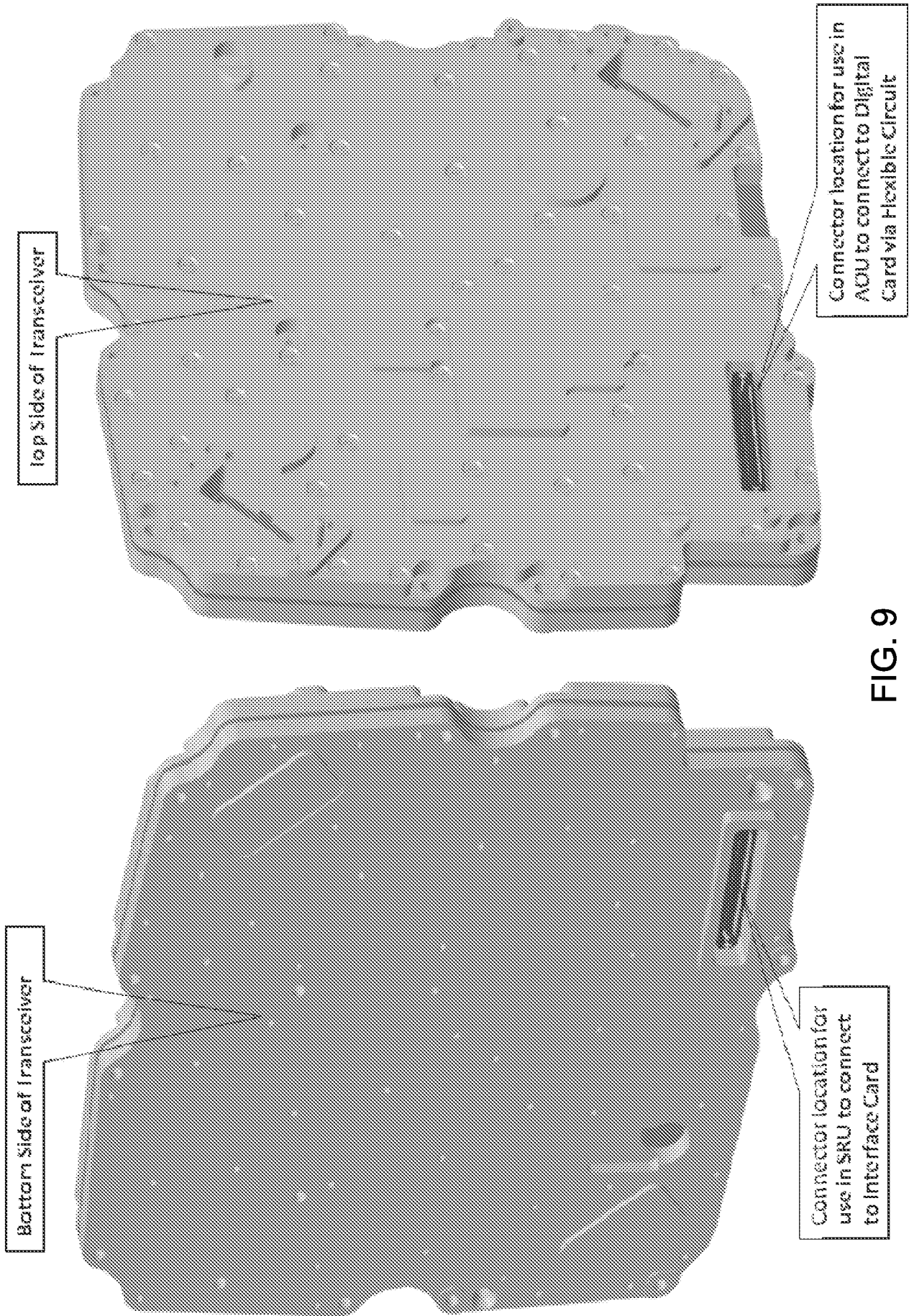

FIG. 9

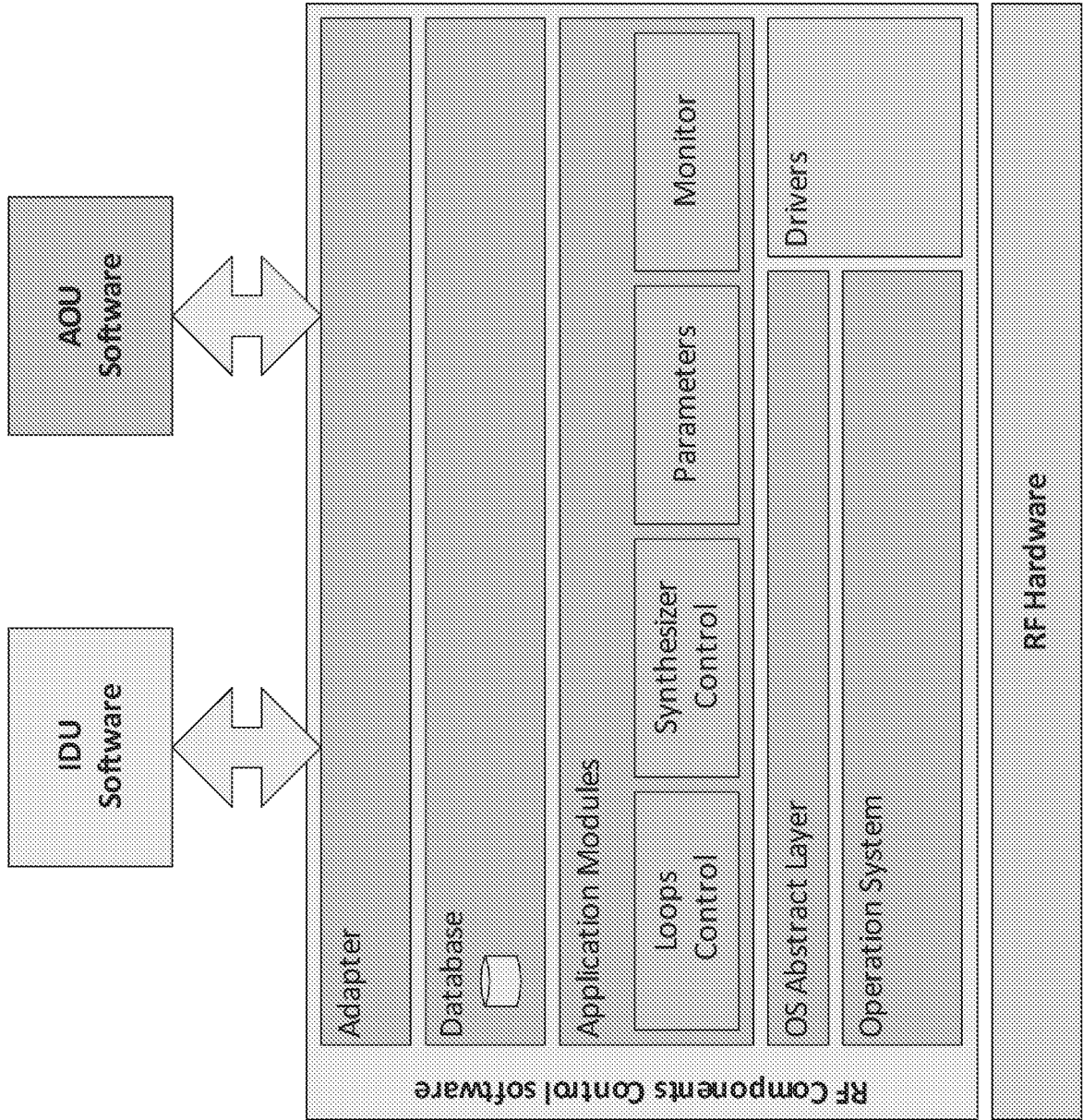

FIG. 10

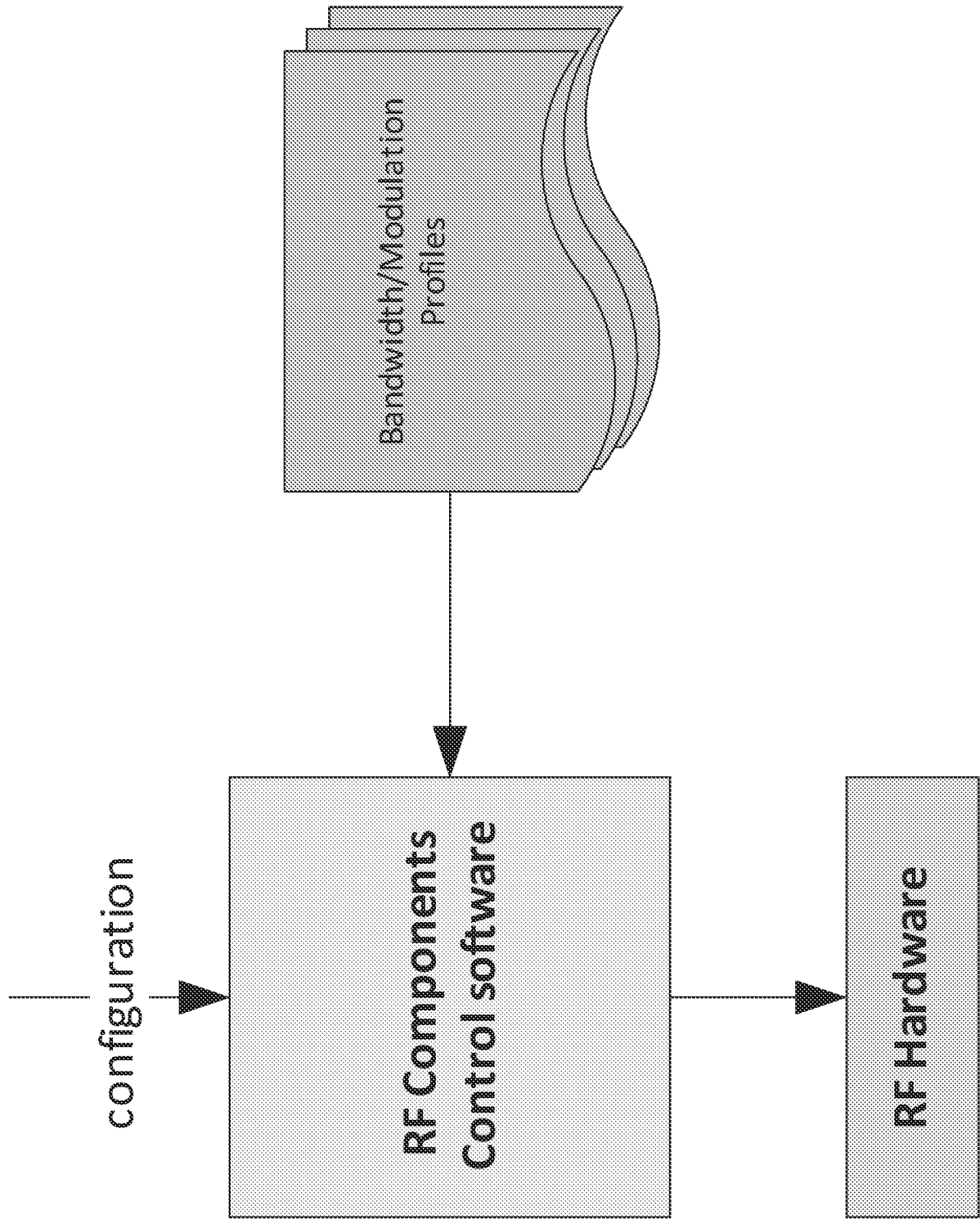

FIG. 11

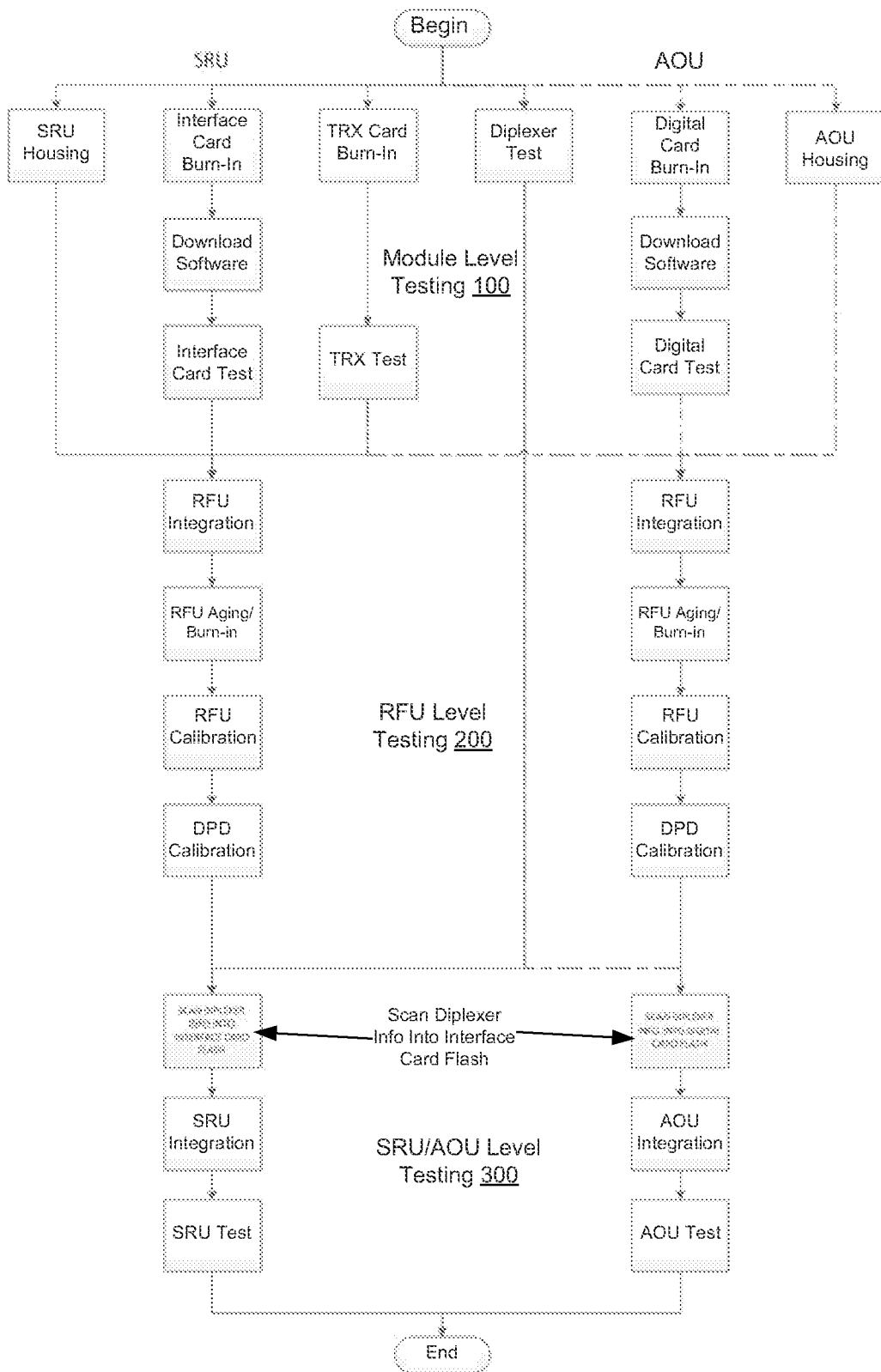

FIG. 12

INTERNATIONAL SEARCH REPORT

International application No.
PCT/US2013/037610**A. CLASSIFICATION OF SUBJECT MATTER****H04B 1/40(2006.01)i**

According to International Patent Classification (IPC) or to both national classification and IPC

B. FIELDS SEARCHEDMinimum documentation searched (classification system followed by classification symbols)
H04B 1/40; H01Q 13/00; H04B 3/00; H04W 72/04; H04H 1/00; H04B 1/38Documentation searched other than minimum documentation to the extent that such documents are included in the fields searched
Korean utility models and applications for utility models
Japanese utility models and applications for utility modelsElectronic data base consulted during the international search (name of data base and, where practicable, search terms used)
eKOMPASS(KIPO internal) & Keywords: ODU, outdoor unit, transceiver, and similar terms.**C. DOCUMENTS CONSIDERED TO BE RELEVANT**

Category*	Citation of document, with indication, where appropriate, of the relevant passages	Relevant to claim No.
X	US 2004-0203528 A1 (AMMAR, DANNY F. et al.) 14 October 2004 See paragraphs [0039]-[0045], [0048], [0049], [0070], [0076], [0078], [0079], [0080], [0089], [0099], [0108], claim 1, and figures 2, 4, 12, 14.	8,9
A		1-3,10-12
A	US 2003-0152140 A1 (ANTONIAK, MICHAEL) 14 August 2003 See paragraphs [0036]-[0042], [0085]-[0087], claim 18, and figures 2-4, 10-12.	1-3,8-12
A	US 5760749 A (MINOWA, YOSHIKI et al.) 02 June 1998 See column 6, line 1 - column 7, line 35, claim 1, and figures 1-3.	1-3,8-12
A	US 2005-01243074 A1 (AMMAR, DANNY F. et al.) 09 June 2005 See paragraphs [0030]-[0038], claim 1, and figures 2, 3.	1-3,8-12
A	US 2012-0093100 A1 (QIN, YOUMING et al.) 19 April 2012 See paragraphs [0039]-[0049] and figures 1, 6.	1-3,8-12

 Further documents are listed in the continuation of Box C. See patent family annex.

* Special categories of cited documents:

"A" document defining the general state of the art which is not considered to be of particular relevance

"E" earlier application or patent but published on or after the international filing date

"L" document which may throw doubts on priority claim(s) or which is cited to establish the publication date of citation or other special reason (as specified)

"O" document referring to an oral disclosure, use, exhibition or other means

"P" document published prior to the international filing date but later than the priority date claimed

"T" later document published after the international filing date or priority date and not in conflict with the application but cited to understand the principle or theory underlying the invention

"X" document of particular relevance; the claimed invention cannot be considered novel or cannot be considered to involve an inventive step when the document is taken alone

"Y" document of particular relevance; the claimed invention cannot be considered to involve an inventive step when the document is combined with one or more other such documents, such combination being obvious to a person skilled in the art

"&" document member of the same patent family

Date of the actual completion of the international search

17 July 2013 (17.07.2013)

Date of mailing of the international search report

18 July 2013 (18.07.2013)

Name and mailing address of the ISA/KR

Korean Intellectual Property Office
189 Cheongsu-ro, Seo-gu, Daejeon Metropolitan City,
302-701, Republic of Korea

Facsimile No. +82-42-472-7140

Authorized officer

PARK Jin Ho

Telephone No. +0424818398



INTERNATIONAL SEARCH REPORT

International application No.

PCT/US2013/037610

Box No. II Observations where certain claims were found unsearchable (Continuation of item 2 of first sheet)

This international search report has not been established in respect of certain claims under Article 17(2)(a) for the following reasons:

- 1. Claims Nos.:
because they relate to subject matter not required to be searched by this Authority, namely:

- 2. Claims Nos.:
because they relate to parts of the international application that do not comply with the prescribed requirements to such an extent that no meaningful international search can be carried out, specifically:

- 3. Claims Nos.: 4-7
because they are dependent claims and are not drafted in accordance with the second and third sentences of Rule 6.4(a).

Box No. III Observations where unity of invention is lacking (Continuation of item 3 of first sheet)

This International Searching Authority found multiple inventions in this international application, as follows:

- I. Claims 1-3 directed to a transceiver used in a radio unit for wireless communication.
- II. Claims 8-10 directed to a split-mount radio unit.
- III. Claims 11-12 directed to an all-outdoor radio unit.

- 1. As all required additional search fees were timely paid by the applicant, this international search report covers all searchable claims.
- 2. As all searchable claims could be searched without effort justifying an additional fee, this Authority did not invite payment of any additional fee.
- 3. As only some of the required additional search fees were timely paid by the applicant, this international search report covers only those claims for which fees were paid, specifically claims Nos.:

- 4. No required additional search fees were timely paid by the applicant. Consequently, this international search report is restricted to the invention first mentioned in the claims; it is covered by claims Nos.:

Remark on Protest

- The additional search fees were accompanied by the applicant's protest and, where applicable, the payment of a protest fee.
- The additional search fees were accompanied by the applicant's protest but the applicable protest fee was not paid within the time limit specified in the invitation.
- No protest accompanied the payment of additional search fees.

INTERNATIONAL SEARCH REPORT

Information on patent family members

International application No.

PCT/US2013/037610

Patent document cited in search report	Publication date	Patent family member(s)	Publication date
US 2004-0203528 A1	14/10/2004	AU 2003-303719 A1 CN 1735999 A EP 1581982 A1 JP 2006-513637 A KR 10-2005-0092400 A NO 20053155 A US 7050765 B2 WO 2004-064197 A1	10/08/2004 15/02/2006 05/10/2005 20/04/2006 21/09/2005 28/09/2005 23/05/2006 29/07/2004
US 2003-0152140 A1	14/08/2003	None	
US 5760749 A	02/06/1998	WO 95-25387 A1	21/09/1995
US 2005-0124307 A1	09/06/2005	WO 2005-057802 A2 WO 2005-057802 A3	23/06/2005 21/07/2005
US 2012-0093100 A1	19/04/2012	WO 2012-047556 A1 WO 2013-023225 A1	12/04/2012 14/02/2013