

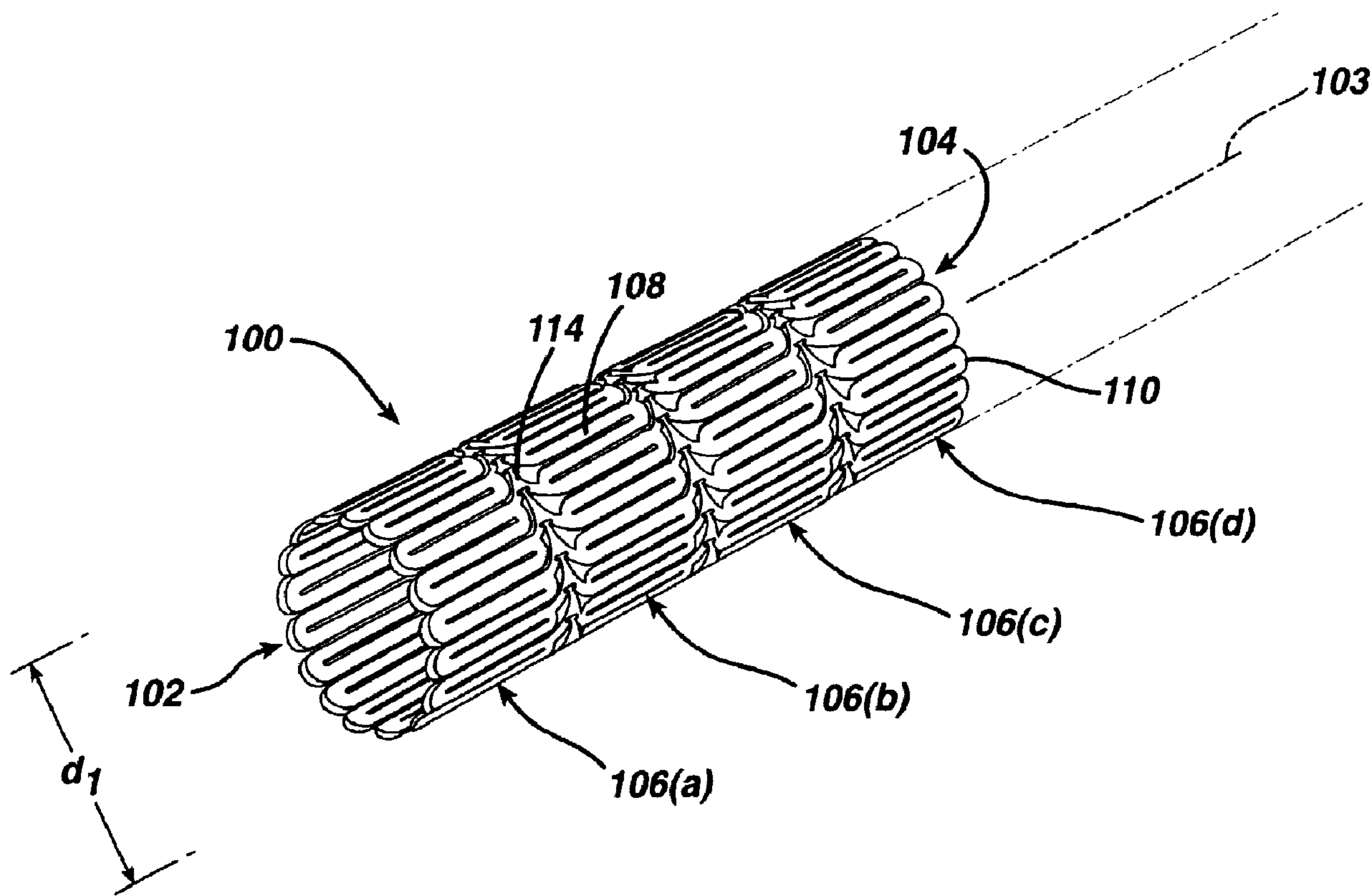

(22) Date de dépôt/Filing Date: 2002/06/05
 (41) Mise à la disp. pub./Open to Public Insp.: 2002/12/08
 (45) Date de délivrance/Issue Date: 2009/09/15
 (30) Priorité/Priority: 2001/06/08 (US09/877,672)

(51) Cl.Int./Int.Cl. *A61M 25/10* (2006.01),
A61F 2/06 (2006.01)
 (72) Inventeur/Inventor:
MATHIS, MARK, US
 (73) Propriétaire/Owner:
CORDIS CORPORATION, US
 (74) Agent: OGILVY RENAULT LLP/S.E.N.C.R.L.,S.R.L.

(54) Titre : DISPOSITIF ET METHODE DE POSE DE DRAIN TUTEUR DANS UN VAISSEAU PAR DECLENCHEMENT D'UN BALLONNET ET ELEMENTS IMBRIQUES
 (54) Title: APPARATUS AND METHOD FOR STENTING A VESSEL USING BALLOON-ACTUATED STENT WITH INTERLOCKING ELEMENTS



(57) Abrégé/Abstract:

An apparatus for stenting a vessel comprises a stent having a lattice of interconnecting elements defining a substantially cylindrical configuration having a first open end and a second open end wherein the lattice is movable between a closed configuration and an open configuration. In one embodiment, the stent includes a plurality of interlocking bridges. In a second embodiment, the stent

(57) **Abrégé(suite)/Abstract(continued):**

includes a plurality of interlocking struts. The apparatus further includes a catheter having an inner sleeve and an expandable member on the inner sleeve wherein the expandable member is movable between a collapsed state and an expanded state. For either embodiment, the stent is secured to the catheter over the expandable member when the expandable member is in the collapsed state and the stent is in the locked configuration. The stent is separated from the catheter when the expandable member is in the expanded state and the stent is in the open configuration. A method for stenting the vessel also includes deploying both stent embodiments at a desired location within a vessel.

**APPARATUS AND METHOD FOR STENTING A VESSEL USING
BALLOON-ACTUATED STENT WITH INTERLOCKING ELEMENTS**

ABSTRACT

5 An apparatus for stenting a vessel comprises a stent having a lattice of
interconnecting elements defining a substantially cylindrical configuration having a
first open end and a second open end wherein the lattice is movable between a
closed configuration and an open configuration. In one embodiment, the stent
includes a plurality of interlocking bridges. In a second embodiment, the stent
includes a plurality of interlocking struts. The apparatus further includes a catheter
10 having an inner sleeve and an expandable member on the inner sleeve wherein the
expandable member is movable between a collapsed state and an expanded state.
For either embodiment, the stent is secured to the catheter over the expandable
member when the expandable member is in the collapsed state and the stent is in the
locked configuration. The stent is separated from the catheter when the expandable
15 member is in the expanded state and the stent is in the open configuration. A
method for stenting the vessel also includes deploying both stent embodiments at a
desired location within a vessel.

**APPARATUS AND METHOD FOR STENTING A VESSEL USING
BALLOON-ACTUATED STENT WITH INTERLOCKING ELEMENTS**

5

FIELD OF THE INVENTION

The present invention relates, in general, to intraluminal medical devices, and, more particularly, to a new and useful stent, stent delivery apparatus and method for stenting a vessel using a stent with interlocking elements.

10

Background Art

15

A stent is commonly used as a tubular structure left inside the lumen of a duct to relieve an obstruction. Commonly, stents are inserted into the lumen in a non-expanded form and are then expanded autonomously (or with the aid of a second device) *in situ*. When used in coronary artery procedures for relieving stenosis, stents are placed percutaneously through the femoral artery. In this type of procedure, stents are delivered on a catheter and are either self-expanding or, in the majority of cases, expanded by a balloon. Self-expanding stents do not need a balloon to be deployed. Rather the stents are constructed using metals with spring-like or superelastic

20

properties (i.e., Nitinol), which inherently exhibit constant radial support. Self-expanding stents are also often used in vessels close to the skin (i.e., carotid arteries) or vessels that can experience a lot of movement (i.e., popliteal artery). Due to a natural elastic recoil, self-expanding stents withstand pressure or shifting and maintain their shape.

25

As mentioned above, the typical method of expansion for balloon expanded stents occurs through the use of a catheter mounted angioplasty balloon, which is inflated within the stenosed vessel or body passageway, in order to shear and disrupt the obstructions associated with the wall components of the vessel and to obtain an

30

enlarged lumen.

Balloon-expandable stents involve crimping the device onto an angioplasty balloon. The stent takes shape as the balloon is inflated and remains in place when the balloon and delivery system are deflated and removed.

5

In addition, balloon-expandable stents are available either pre-mounted or unmounted. A pre-mounted system has the stent already crimped on a balloon, while an unmounted system gives the physician the option as to what combination of devices (catheters and stents) to use. Accordingly, for these types of procedures, the stent is first introduced into the blood vessel on a balloon catheter. Then, the balloon is inflated causing the stent to expand and press against the vessel wall. After expanding the stent, the balloon is deflated and withdrawn from the vessel together with the catheter. Once the balloon is withdrawn, the stent stays in place permanently, holding the vessel open and improving the flow of blood.

10

15

In the absence of a stent, restenosis may occur as a result of elastic recoil of the stenotic lesion. Although a number of stent designs have been reported, these designs have suffered from a number of limitations. Some of these limitations include premature deployment of the stent due to circumstances such as over-manipulation when traversing tortuous vessels or the inability to maintain the stent secured to the balloon due to migration, slippage, etc.

20

Accordingly, to date, there have not been any stent designs, that specifically address these drawbacks in an efficient and cost effective manner.

25

Brief Summary of the Invention

The present invention relates to an apparatus and its use for stenting a vessel in conjunction with a particular new and useful stent having a lattice of interconnecting elements defining a substantially cylindrical configuration. The lattice has a first open end
5 and a second open end wherein the lattice is movable between a locked configuration and an open configuration.

One embodiment of the stent includes a plurality of bridges connecting the interconnecting elements wherein each bridge interlocks with an adjacent bridge in the locked configuration and wherein each bridge separates from the adjacent bridge in the
10 open configuration.

In another embodiment, the interlocking elements include a plurality of struts wherein each strut interlocks with an adjacent strut in the locked configuration and each strut separates from the adjacent strut in the open configuration.

Accordingly, in one embodiment, the present invention provides an apparatus for
15 stenting a vessel comprising: a stent having a lattice of interconnecting elements including a plurality of adjacent hoops, each hoop comprising a plurality of loops, and the lattice defining a substantially cylindrical configuration having a first open end and a second open end, the lattice being movable between a locked configuration and an open configuration, and a plurality of bridges, each bridge having a first end and a second end,
20 the first end of each bridge being attached to a loop of one hoop and the second end of each bridge attached a loop on an adjacent hoop when the stent is in the locked configuration and the open configuration, each bridge interlocking with an adjacent bridge in the locked configuration and each bridge separating from the adjacent bridge in the open configuration; and a catheter having an inner sleeve and an expandable member
25 on the inner sleeve, the expandable member being movable between a collapsed state and an expanded state, the stent being secured to the catheter over the expandable member when the expanded member is in the collapsed state and the stent is in the locked

configuration and the stent being separated from the catheter when the expanded member is in the expanded state and the stent is in the open configuration.

5 In another embodiment, the present invention provides an apparatus for stenting a vessel comprising: a stent having a lattice of interconnecting elements including a plurality of adjacent hoops, each hoop comprising a plurality of loops, and the lattice defining a substantially cylindrical configuration having a first open end and a second open end, the lattice having a locked configuration and an open configuration, the interconnecting elements including a plurality of bridges, each bridge having a first end and a second end, the first end of each bridge being attached to a loop of one hoop and the second end of each bridge attached to a loop on an adjacent hoop when the stent is in the locked configuration and the open configuration, a plurality of struts, each strut interlocking with an adjacent strut in the locked configuration and each strut separating from the adjacent strut in the open configuration; and a catheter having an inner sleeve and an expandable member on the inner sleeve, the expandable member being movable between a collapsed state and an expanded state, the stent being secured to the catheter over the expandable member when the expandable member is in the collapsed state and the stent is in the locked configuration and the stent being separated from the catheter when the expandable member is in the expanded state and the stent is in the open configuration.

20 In one embodiment of the interlocking bridge embodiment, each bridge has a projection and a base wherein the base has a projection holding section for receiving the projection from an adjacent bridge. Likewise, for an interlocking strut embodiment, each strut has a projection and a base wherein the base has a projection holding section for receiving the projection from an adjacent strut. Accordingly, for both of the stent 25 embodiments described here, several features are in common. For instance, the interlocking elements comprise a plurality of adjacent sections. Additionally, the adjacent sections comprise adjacent hoops wherein each hoop comprises a plurality of loops. Each loop comprises at least one strut.

For both this interlocking bridge embodiment and interlocking strut embodiment, lateral arms extend from the base. Moreover, the projection holding section of the base has an opening therein for receiving the projection. An extension is connected between the base and the projection, and, for the interlocking bridge embodiment, the extension includes a neck wherein the projection is located at a superior position on the neck.

The projection also includes at least one lateral lip and the projection holding section includes at least one lateral ledge for releasably engaging the at least one lateral lip of the projection. The projection also includes at least one sidewall adjacent to the at least one lateral lip. Additionally, the projection holding section includes at least one lateral depression adjacent to the at least one lateral ledge for releasably engaging the at least one sidewall of the projection.

Although these features are intended to encompass any suitable configuration, in a preferred embodiment, the at least one sidewall is curved and the at least one depression is curved wherein these elements are aligned, snapped-fit or interlock in a puzzle-lock manner. Moreover, the lateral arms of the base connect directly to the interconnecting elements of the lattice.

The stent of the present invention is directed toward both a balloon actuated stent and a self-expanding stent. The stent is made of any suitable material. In one embodiment, the stent is made of an alloy such as stainless steel. In another preferred embodiment, the stent is made of a nickel titanium (Nitinol) alloy. Moreover, this material or any other super-elastic alloy is suitable for the stent according to the present invention. In these self-expanding stent embodiments, the stent is a crush recoverable stent.

The present invention is also directed toward an apparatus and method for stenting a vessel utilizing the stent embodiments described above, e.g., a stent having a lattice of interconnecting elements and including interlocking features such as a plurality of interlocking bridges in one embodiment or a plurality of interlocking struts in another embodiment.

The apparatus further includes a catheter having an inner sleeve and an expandable member on the inner sleeve wherein the expandable member is movable between a collapsed state and an expanded state. One of the stent embodiments described above is secured to the catheter over the expandable member when the expandable member is in the collapsed state and the stent is in the locked configuration. The stent is separated or deployed from the catheter when the expandable member is in the expanded state and the stent is in the open configuration. The apparatus further includes a cover movably disposed over the stent. The cover is an outer sheath made of a polymer material. Additionally, the expandable member is an inflatable balloon.

The method for stenting a vessel according to the present invention comprises the steps of providing the apparatus according to the present invention have one of the stent embodiments, e.g., the interlocking bridge embodiment or the interlocking strut embodiment, and inserting the apparatus within a vessel. The distal end of the apparatus is positioned at a desired location within the vessel and the stent is deployed to the open configuration with the expandable member.

Additionally, the method further includes providing the cover movably disposed over the stent for preventing the stent from moving to the open configuration until desired. The method further comprises deploying the stent to the open configuration by inflation of the expandable member.

5 Additionally, the method further comprises securing the stent to the catheter by interlocking the bridges (for the interlocking bridge embodiment) or by interlocking the struts (for the interlocking strut embodiment) prior to performing certain steps according to the present invention. Lastly, the method according to the present invention also comprises removing the catheter from the patient after the deployment of the stent.

BRIEF DESCRIPTION OF THE DRAWINGS

10 The novel features of the invention are set forth with particularity in the appended claims. The invention itself, however, both as to organization and methods of operation, together with further objects and advantages thereof, may be best understood by reference to the following description, taken in conjunction with the accompanying drawings in which:

 Fig 1A is a perspective view of a first embodiment of a stent in a closed configuration in accordance with the present invention;

20 Fig 1B is a perspective view of a second embodiment of a stent in a closed configuration in accordance with the present invention;

 Fig 2A is a partial side plan view of an interlocking bridge for the stent of Fig 1A;

25 Fig 2B is a partial side plan view of an interlocking strut for the stent of Fig 1B;

- 7 -

Fig 3A is a partial side view of the lattice of the stent of Fig 1A;

Fig 3B is a partial side view of the lattice of the stent of Fig 1B;

5 Fig 4A is a partial perspective view of the stent of Fig 1A in an open configuration;

Fig 4B is a partial perspective view of the stent of Fig 1B in an open configuration;

10

Fig 5A is a partial perspective view of a distal end of an apparatus according to the present invention utilizing the stent of Fig 1A; and

15

Fig 5B is a partial perspective view of a distal end of an apparatus according to the present invention utilizing the stent of Fig 1B.

DETAILED DESCRIPTION OF THE INVENTION

20 In Figs. 1A, 1B, 4A and 4B, a stent 100 that is an expandable prosthesis for a body passageway is illustrated. It should be understood that the terms "stent" and "prosthesis" are interchangeably used to some extent in describing the present invention, insofar as the method, apparatus, and structures of the present invention may be utilized not only in connection with an expandable intraluminal vascular graft for expanding partially occluded segments of a blood vessel, duct or body
25 passageways, such as within an organ, but may so be utilized for many other purposes as an expandable prosthesis for many other types of body passageways. For example, expandable prostheses may also be used for such purposes as: (1) supportive graft placement within blocked arteries opened by transluminal

recanalization, but which are likely to collapse in the absence of internal support; (2) similar use following catheter passage through mediastinal and other veins occluded by inoperable cancers; (3) reinforcement of catheter created intrahepatic communications between portal and hepatic veins in patients suffering from portal hypertension; (4) supportive graft placement of narrowing of the esophagus, the intestine, the ureters, the urethra, etc.; (5) intraluminally bypassing a defect such as an aneurysm or blockage within a vessel or organ; and (6) supportive graft reinforcement of reopened and previously obstructed bile ducts. Accordingly, use of the term "prosthesis" encompasses the foregoing usages within various types of body passageways, and the use of the term "intraluminal graft" encompasses use for expanding the lumen of a body passageway. Further in this regard, the term "body passageway" encompasses any lumen or duct within the human body, such as those previously described, as well as any vein, artery, or blood vessel within the human vascular system.

The stent 100 is an expandable lattice structure made of any suitable material which is compatible with the human body and the bodily fluids (not shown) with which the stent 100 may come into contact. The lattice structure is an arrangement of interconnecting elements made of a material which has the requisite strength and elasticity characteristics to permit the tubular shaped stent 100 to be expanded from the closed configuration shown in Figs. 1A and 1B to the expanded configuration shown in Figs. 4A and 4B and further to permit the stent 100 to retain its expanded configuration at the enlarged diameter d_1 . Suitable materials for the fabrication of the stent 100 include silver, tantalum, stainless steel, gold, titanium or any suitable plastic material having the requisite characteristics previously described. In one embodiment, the stent is fabricated from 316L stainless steel alloy

In a preferred embodiment, the stent 100 comprises a superelastic alloy such as nickel titanium (NiTi, e. g., Nitinol). More preferably, the stent 100 is formed from an alloy comprising from about 50.5 to 60.0% Ni by atomic weight and the remainder Ti. Even more preferably, the stent 100 is formed from an alloy
5 comprising about 55% Ni and about 45% Ti. The stent 100 is preferably designed such that it is superelastic at body temperature, and preferably has an Af temperature in the range from about 24° C to about 37° C. The superelastic design of the stent 100 makes it crush recoverable and thus suitable as a stent or frame for any number of vascular devices for different applications.

10

The stent 100 comprises a tubular configuration formed by a lattice of interconnecting elements defining a substantially cylindrical configuration and having front and back open ends 102, 104 and defining a longitudinal axis 103 extending therebetween. In its closed configuration, the stent 100 has a first
15 diameter (d_1) for insertion into a patient and navigation through the vessels and, in its open configuration, a second diameter (d_2), as shown in Figs. 4A and 4B, for deployment into the target area of a vessel with the second diameter being greater than the first diameter. The stent 100 comprises a plurality of adjacent hoops 106(a)-(d) extending between the front and back ends 102, 104. The hoops 106(a)-
20 (d) include a plurality of longitudinally arranged struts 108 and a plurality of loops 110 connecting adjacent struts 108. Adjacent struts 108 are connected at opposite ends so as to form a substantially S or Z shape pattern. The plurality of loops 110 have a substantially semi-circular configuration and are substantially symmetric about their centers.

25

The stent 100 further comprises a plurality of bridges 114, which connect adjacent hoops 106(a)-(d). The details of the bridges 114 are more fully illustrated in Figs. 2A, and 3A and described below. Each bridge comprises two ends wherein

- 10 -

one end of each bridge 114 is attached to one loop 110 on one hoop 106(a) and the other end of each bridge 114 is attached to one loop 110 on an adjacent hoop 106(b). The bridges 114 connect adjacent hoops 106(a)-(d) together at bridge to loop connection regions 120,122 as shown in Fig. 2A.

5

The above-described geometry better distributes strain throughout the stent 100, prevents metal to metal contact where the stent 100 is bent, and minimizes the opening between the features of the stent 100; namely, struts 108, loops 110 and bridges 114. The number of and nature of the design of the struts, loops and bridges are important design factors when determining the working properties and fatigue life properties of the stent 100. It was previously thought that in order to improve the rigidity of the stent, struts should be large, and thus there should be fewer struts 108 per hoop 106(a)-(d). However, it is now known that stents 100 having smaller struts 108 and more struts 108 per hoop 106(a)-(d) improve the construction of the stent 100 and provide greater rigidity. Preferably, each hoop 106(a)-(d) has between twenty-four (24) to thirty-six (36) or more struts 108. It has been determined that a stent having a ratio of number of struts per hoop to strut length which is greater than four hundred has increased rigidity over prior art stents which typically have a ratio of under two hundred. The length of a strut is measured in its compressed state parallel to the longitudinal axis 103 of the stent 100 as illustrated in Fig. 1A.

10

15

20

25

Fig. 4A illustrates the stent 100 in its open or expanded state. As may be seen from a comparison between the stent 100 configuration illustrated in Fig. 1A and the stent 100 configuration illustrated in Fig. 4A, the geometry of the stent 100 changes quite significantly as it is deployed from its unexpanded state (closed or locked configuration) to its expanded state (open or unlocked configuration). As the stent 100 undergoes diametric change, the strut angle and strain levels in the loops 110 and bridges 114 are affected. Preferably, all of the stent features will strain in a

predictable manner so that the stent 100 is reliable and uniform in strength. In addition, it is preferable to minimize the maximum strain experienced by the struts 108, loops 110 and bridges 114 since Nitinol properties are more generally limited by strain rather than by stress. The embodiments illustrated in Figs. 1A-5B has a design to help minimize forces such as strain.

Fig. 1A illustrates the first embodiment of the stent 100 according to the present invention including a plurality of interlocking bridges 114 connecting adjacent hoops 106(a)-(d). In this embodiment, as best illustrated in Fig. 2A, stent 100 has bridges 114 wherein each bridge 114 includes a base 126. The base 126 has a pair of laterally extending arms 128 wherein each end of the lateral arms 128 are connected directly to a loop 110 at loop connection regions 120 and 122. Accordingly, one laterally extending arm connects to one of the adjacent hoops 106(a)-(d) at the loop connection region 120 of one loop 110 and the other lateral extending arm 128 of the bridge 114 is connected to an adjacent loop 110 at the loop connection region 122. Thus, the bridge 114 alternatively connects adjacent hoops 106(a)-(d).

The bridge 114 further includes an extension 130 extending in a superior direction from the base 126. The extension 130 includes a neck 131 at the superior end of the extension 130. A projection 132 is fixed to the superior end of the neck 131 of the extension 130. Although the projection 132 can comprise any desired configuration, one preferred configuration for the projection 132 includes a pair of lateral lips 134 laterally extending from the neck 131 and a pair of lateral sidewalls 136 extending from the lateral lips 134 respectively. In this embodiment, the lateral sidewalls 136 have a curved-shape. Additionally, the projection 132 further includes an upper edge 137 extending between the lateral sidewalls 136.

- 12 -

The bridge 114 further includes a projection holding section 140 inferior to the extension 130 at the base 126. The projection holding section 140 is defined by an opening 142 in the base 126. The projection holding section 140 further includes a pair of lateral ledges 144 extending from each side of the opening 142. The
5 projection holding section 140 further includes a lateral depression 146 extending from each lateral ledge 144. Each lateral depression 146 also has a curved-shape for this embodiment. Additionally, the projection holding section 140 includes an upper edge 147 extending between each lateral depression 146.

10 The projection holding section 140 is shaped to fit and receive in a snap-fit or puzzle-lock manner the projection 132 of an adjacent bridge 114. Due to the unique configuration of the bridge 114, the projection 132 of a first bridge 114 is interlocked with the projection holding section 140 of a second bridge 114. The interlocking of bridges 114, which can be adjacent bridges, is accomplished by
15 insertion of the projection 132 of the first bridge 114 into the central opening 142 of the projection holding section 140 of the second bridge 114 such that the lateral lips 134 releasably engage the lateral ledges 144 of the projection holding section 140. Moreover, the lateral sidewalls 136 of the projection 132 mates, in a releasable fashion, with the lateral depressions 146 of the projection holding section 140 of the
20 second bridge 114. Furthermore, the upper edge 137 of the projection 132 of the first bridge 114 releasably mates with the upper edge 147 of the projection holding section 140 of the second bridge 114. Accordingly, this arrangement insures for an interlocking of the first and second bridges 114, e.g., adjacent bridges 114, in a puzzle-like manner. This arrangement of interlocking bridges 114 is clearly
25 illustrated in Fig. 3A. When deployed to an open configuration, the stent 100 for the interlocking bridge embodiment described above expands to a width D_2 as shown in Fig 4A.

- 13 -

A second embodiment for the stent 100 is shown in Fig. 1B and includes a plurality of interlocking struts 108a. In this embodiment, adjacent hoops 106(a) – (d) are connected to each other by nonlocking bridges 114a.

5 For the embodiment of Fig. 1B (the interlocking strut embodiment), a plurality of interlocking struts 108a are utilized in order to interlock by releasable engagement a first strut 108a with a second strut 108a as best shown in Fig. 3B.

10 For purposes of this disclosure, the same reference numerals are used to designate like or similar features for both the interlocking bridge 114 embodiment (Fig. 1A) and the interlocking strut 108a embodiment (Fig. 1B). Accordingly, each interlocking strut 108a includes base 126 and laterally extending sidearms 128 as shown in Fig 2B.

15 As illustrated in Fig. 2B, the strut 108a further includes extension 130 extending in a superior direction from the base 126. Projection 132 is fixed to the superior end of the extension 130. Although the projection 132 can comprise any desired configuration, one preferred configuration for the projection 132 includes a pair of lateral lips 134 laterally extending from the extension 130 and a pair of
20 lateral sidewalls 136 extending from the lateral lips 134 respectively. In this embodiment, the lateral sidewalls 136 have a curved-shape. Additionally, the projection 132 further includes upper edge 137 extending between the sidewalls 136.

25 The strut 108a (of the interlocking strut embodiment) further includes projection holding section 140 inferior to the extension 130 at the base 126. The projection holding section 140 is defined by opening 142 in the base 126. The projection holding section 140 further includes a pair of lateral ledges 144 extending

from each side of the opening 142. The projection holding section 140 further includes lateral depression 146 extending from each lateral ledge 144. Each lateral depression 146 also has a curved-shape for this embodiment. Additionally, the projection holding section 140 includes upper edge 147 extending between each lateral depression 146.

As best illustrated in Fig. 3B, the projection holding section 140 is shaped to fit and receive in a snap-fit or puzzle-lock manner the projection 132 of an adjacent strut 108a. Due to the unique configuration of the strut 108a, the projection 132 of a first strut 108a is interlocked with the projection holding section 140 of a second strut 108a. The interlocking of struts 108a, which can be adjacent struts, is accomplished by insertion of the projection 132 of the first strut 108a into the central opening 142 of the projection holding section 140 of the second strut 108a such that the lateral lips 134 releasably engage the lateral ledges 144 of the projection holding section 140. Moreover, the lateral sidewalls 136 of the projection 132 mates, in a releasable fashion, with the lateral depressions 146 of the projection holding section 140 of the second strut 108a. Furthermore, the upper edge 137 of the projection 132 of the first strut 108a releasably mates with the upper edge 147 of the projection holding section 140 of the second strut 108a. Accordingly, this arrangement insures for an interlocking of the first and second struts 108a, e.g., adjacent struts 108a, in a puzzle-like manner. This arrangement of interlocking struts 108a is clearly illustrated in Fig. 3B. Thus, the first strut 108a releasably engages with or interlocks with the second strut 108a in a puzzle-lock manner.

As mentioned above with the interlocking bridge embodiment of Fig. 4A, as shown in Fig. 4B, the stent 100 having the interlocking struts 108a (the interlocking strut embodiment) is deployed or expanded to an open configuration having a width D_2 .

- 15 -

The stent 100 according to the present invention for both the interlocking bridge 114 embodiment and the interlocking strut 108a embodiment is directed toward both deployment or expansion through an expandable member such as a balloon (to be described in greater detail below) and a self-expanding stent, i.e., a stent that is crush recoverable.

The present invention also includes an apparatus and method for stenting a vessel utilizing the stent 100 (both the interlocking bridge 114 embodiment and the interlocking strut 108a embodiment). The stenting apparatus according to the present invention is generally designated 200 as best shown in Figs. 5A and 5B. Fig. 5A illustrates the apparatus 200 (as a catheter) which includes the stent 100 (the interlock bridge 114 embodiment) and Fig. 5B illustrates the apparatus 200 including the second embodiment for the stent 100 (the interlocking strut 108a embodiment). As illustrated in Figs. 5A and 5B, the catheter 200 has a distal end 210 culminating in a distal tip 215. The catheter 200 includes an inner sleeve 220 extending to the distal tip 215. An expandable member 230, such as an inflatable balloon, is fixed to the inner sleeve 220 at the distal end 210 of the catheter 200. As is well understood in the field, the expandable member 230 is expanded, such as through inflation with a hydraulic or pneumatic fluid, and is expandable from a collapsed or closed configuration to an open or expanded configuration. The stent 100 (both embodiments of Figs. 1A and 1B) according to the present invention are secured to the distal end of the catheter 200 by closing the stent 100 over the expandable member 230 and the inner sleeve 220 as best illustrated in Figs. 5A and 5B. The stent 100 is secured to the catheter 200 by closing the stent 100 respectively by moving the stent 100 and to its locked configuration. As described above, the locked configuration for the stent 100 includes interlocking the bridges 114 (for the interlocking bridge embodiment Fig. 5A) and for interlocking the struts

- 16 -

108a (for the intrelocking strut embodiment Fig. 5B) in the respective manner described above.

5 In securing the stent 100 to the catheter distal end 210 for the interlocking bridge embodiment of Fig. 5A, the bridges 114 are moved and interlocked (as shown in Fig. 3A) such that the stent 100 is locked and in its closed configuration over the expandable member 230.

10 In securing the stent 100 to the catheter distal end 210 for the interlocking strut embodiment of Fig. 5B, the struts 108a are moved and interlocked (as shown in Fig. 3B) such that the stent 100 is locked and in its closed configuration over the expandable member 230.

15 For both embodiments mentioned above, the stent 100 is thereby secured to the catheter 200 until deployment is desired. An outer sheath 240, which is made of a polymer material such as polyethylene, is used as a cover for the catheter distal end 210 and serves as an additional form of protection for securing of the stent 100 (both embodiments) to the catheter distal end 210. The cover 240 is movably positioned or movably disposed from the catheter distal end 210 in order to provide
20 both the protection as described above as well as the unimpeded deployment of the stent 100 upon positioning of the stent 100 at its desired location.

25 The method of utilizing the catheter 200 according to the present invention includes first identifying a location in a patient's body for deployment of the stent 100. Upon identifying the desired deployment location, the catheter 200 is inserted within a vessel in the patient's body. The catheter 200 is used to traverse the vessel until reaching the desired location wherein the distal end 210 of the catheter 200 is positioned at the desired location within the vessel. At this point, the stent 100 is

- 17 -

deployed to its open configuration by expanding the expandable member 230 such as by inflation. If the cover 240 is utilized to further protect and secure the stent 100 to the catheter distal end 210, the cover 240 is removed from the distal end 210 prior to expansion of the expandable member 230.

5

Upon expanding the stent 100 to its open configuration, the expandable member 230 is then collapsed, for instance through deflation of the expandable member, whereby the catheter 200 is removed from the deployment site of the vessel and patient's body altogether.

10

While preferred embodiments of the present invention have been shown and described herein, it will be obvious to those skilled in the art that such embodiments are provided by way of example only. Numerous variations, changes, and substitutions will now occur to those skilled in the art without departing from the invention. Accordingly, it is intended that the invention be limited only by the spirit and scope of the appended claims.

15

What is Claimed:**1. An apparatus for stenting a vessel comprising:**

a stent having a lattice of interconnecting elements including a plurality of adjacent hoops, each hoop comprising a plurality of loops, and the lattice defining a substantially cylindrical configuration having a first open end and a second open end, the lattice being movable between a locked configuration and an open configuration, and a plurality of bridges, each bridge having a first end and a second end, the first end of each bridge being attached to a loop of one hoop and the second end of each bridge attached a loop on an adjacent hoop when the stent is in the locked configuration and the open configuration, each bridge interlocking with an adjacent bridge in the locked configuration and each bridge separating from the adjacent bridge in the open configuration;

a catheter having an inner sleeve and an expandable member on the inner sleeve, the expandable member being movable between a collapsed state and an expanded state, the stent being secured to the catheter over the expandable member when the expanded member is in the collapsed state and the stent is in the locked configuration and the stent being separated from the catheter when the expanded member is in the expanded state and the stent is in the open configuration.

2. The apparatus according to claim 1, wherein the catheter includes a cover movably disposed over the stent.

3. The apparatus according to claim 1, wherein the expandable member is an inflatable balloon.

4. The apparatus according to claim 2, wherein the cover is an outer sheath.

5. The apparatus according to claim 4, wherein the sheath is made of a polymer.

6. The apparatus according to claim 1, wherein the stent is made of an alloy.

7. The apparatus according to claim 6, wherein the stent is made of stainless steel.

8. The apparatus according to claim 6, wherein the stent is made of a superelastic alloy.
9. The apparatus according to claim 8, wherein the stent is made of nickel titanium (NiTi).
10. The apparatus according to claim 1, wherein the stent is crush recoverable.
11. The apparatus according to claim 10, wherein the stent is made of nickel titanium (NiTi).
12. The apparatus according to claim 1, wherein each bridge has a projection and a base, the base having a projection holding section for receiving the projection from the adjacent bridge.
13. The apparatus according to claim 12, wherein each hoop comprises at least one strut.
14. The apparatus according to claim 12, wherein each bridge has lateral arms extending from the base.
15. The apparatus according to claim 14, wherein the projection holding section has an opening therein.
16. The apparatus according to claim 15, wherein an extension is connected between the base and the projection.
17. The apparatus according to claim 16, wherein the extension includes a neck and the projection is located at a superior position on the neck.
18. The apparatus according to claim 17, wherein the projection includes at least one lateral lip.

19. The apparatus according to claim 18, wherein the projection holding section includes at least one lateral ledge for releasable engaging the at least one lateral lip of the projection.
20. The apparatus according to claim 19, wherein the projection includes at least one sidewall adjacent the at least one lateral lip.
21. The apparatus according to claim 20, wherein the projection holding section includes at least one lateral depression adjacent the at least one lateral ledge for releasably engaging the at least one sidewall of the projection.
22. The apparatus according to claim 21, wherein the at least one sidewall is curved.
23. The apparatus according to claim 22, wherein the at least one depression is curved.
24. The apparatus according to claim 23, wherein the lateral arms connect the interconnecting elements.
25. The use of the apparatus according to any one of claims 1 to 24 for stenting a vessel.
26. The use of the apparatus according to claim 1, wherein the catheter further includes a cover movably disposed over the stent for preventing the stent from moving to the open configuration during insertion of the apparatus within the vessel and positioning of the distal end of the apparatus at a desired location within the vessel.
27. The use according to claim 25, wherein the stent is deployable to the open configuration by inflation of the expandable member.
28. The use according to claim 25, wherein the stent is securable to the catheter by interlocking the bridges prior to insertion, positioning and deployment.
29. An apparatus for stenting a vessel comprising:

I. a stent having a lattice of interconnecting elements including a plurality of adjacent hoops, each hoop comprising a plurality of loops, and the lattice defining a substantially cylindrical configuration having a first open end and a second open end, the lattice having a locked configuration and an open configuration, the interconnecting elements including a plurality of bridges, each bridge having a first end and a second end, the first end of each bridge being attached to a loop of one hoop and the second end of each bridge attached to a loop on an adjacent hoop when the stent is in the locked configuration and the open configuration, a plurality of struts, each strut interlocking with an adjacent strut in the locked configuration and each strut separating from the adjacent strut in the open configuration and wherein each hoop includes at least one strut;

II. a catheter having an inner sleeve and an expandable member on the inner sleeve, the expandable member being movable between a collapsed state and an expanded state, the stent being secured to the catheter over the expandable member when the expandable member is in the collapsed state and the stent is in the locked configuration and the stent being separated from the catheter when the expandable member is in the expanded state and the stent is in the open configuration.

30. The apparatus according to claim 29, wherein the catheter includes a cover movably disposed over the stent.

31. The apparatus according to claim 30, wherein the cover is an outer sheath.

32. The apparatus according to claim 31, wherein the sheath is made of a polymer.

33. The apparatus according to claim 29, wherein the expandable member is an inflatable balloon.

34. The apparatus according to claim 29, wherein the stent is made of an alloy.

35. The apparatus according to claim 34, wherein the stent is made of stainless steel.

36. The apparatus according to claim 34, wherein the stent is made of a superelastic alloy.

37. The apparatus according to claim 36, wherein the stent is made of nickel titanium (NiTi).
38. The apparatus according to claim 31, wherein the stent is crush recoverable.
39. The apparatus according to claim 38, wherein the stent is made of nickel titanium (NiTi).
40. The apparatus according to claim 29, wherein each strut has a projection and a base, the base having a projection holding section for receiving the projection from the adjacent strut.
41. The apparatus according to claim 40, wherein each strut has lateral arms extending from the base.
42. The apparatus according to claim 41, wherein the projection holding section has an opening therein.
43. The apparatus according to claim 42, wherein an extension is connected between the base and the projection.
44. The apparatus according to claim 43, wherein the projection includes at least one lateral lip.
45. The apparatus according to claim 44, wherein the projection holding section includes at least one lateral ledge for releasably engaging the at least one lateral lip of the projection.
46. The apparatus according to claim 45, wherein the projection includes at least one sidewall adjacent the at least one lateral lip.
47. The apparatus according to claim 46, wherein the projection holding section includes at least one lateral depression adjacent the at least one lateral ledge for releasably engaging the at least one sidewall of the projection.

48. The apparatus according to claim 47, wherein the at least one sidewall is curved.
49. The apparatus according to claim 48, wherein the at least one depression is curved.
50. The apparatus according to claim 49, wherein the lateral arms connect the interconnecting elements.
51. The use of the apparatus according to any one of claims 29 to 50 for stenting a vessel.
52. The use of the apparatus according to claim 29, wherein the catheter further includes a cover movably disposed over the stent for preventing the stent from moving to the open configuration during insertion of the apparatus within a vessel and positioning of the distal end of the apparatus at a desired location within the vessel.
53. The use according to claim 51, wherein the stent is deployable to the open configuration by inflation of the expandable member.
54. The use according to claim 51, wherein the stent is securable to the catheter by interlocking the struts prior to insertion, positioning and deployment.

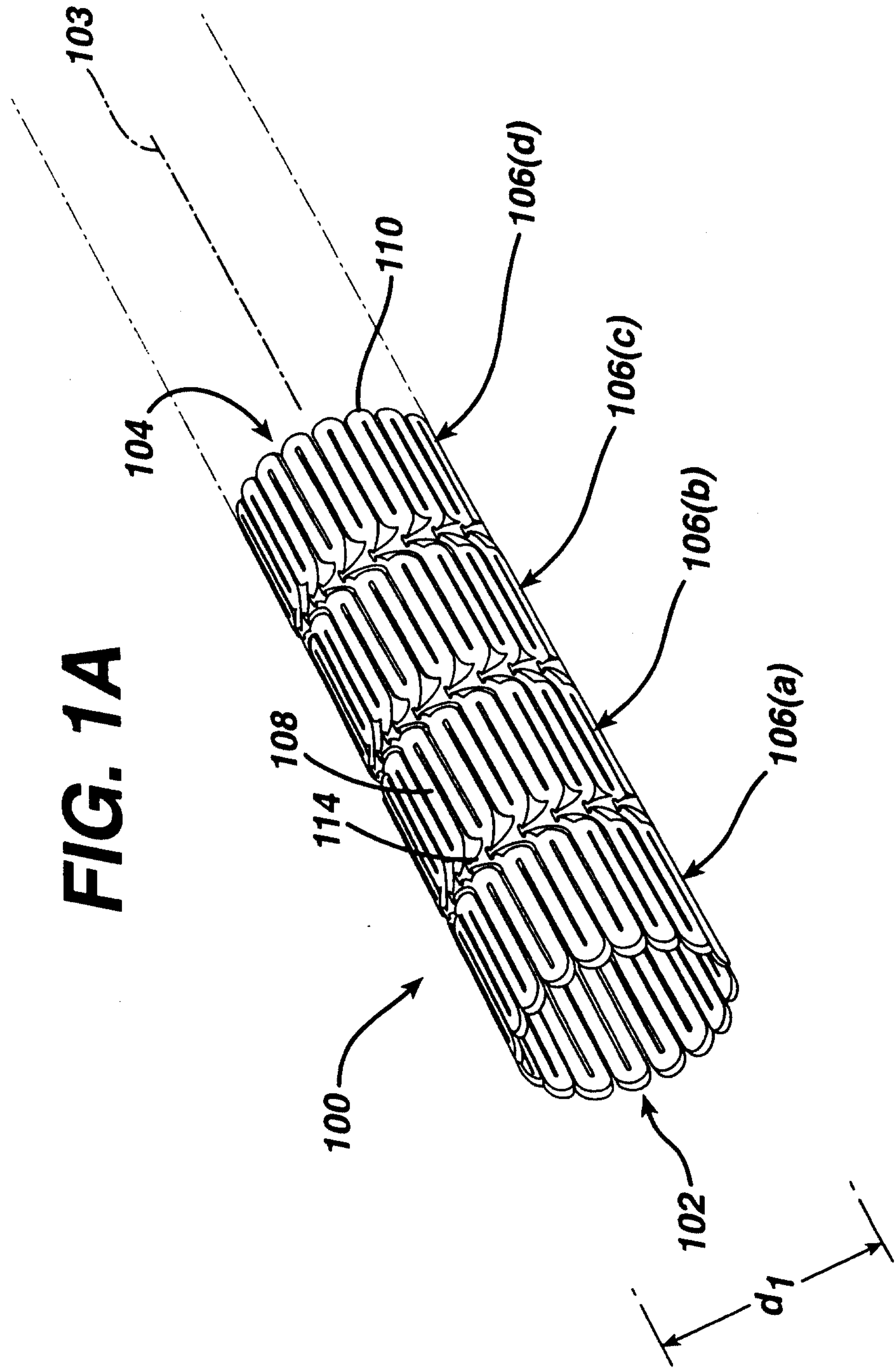

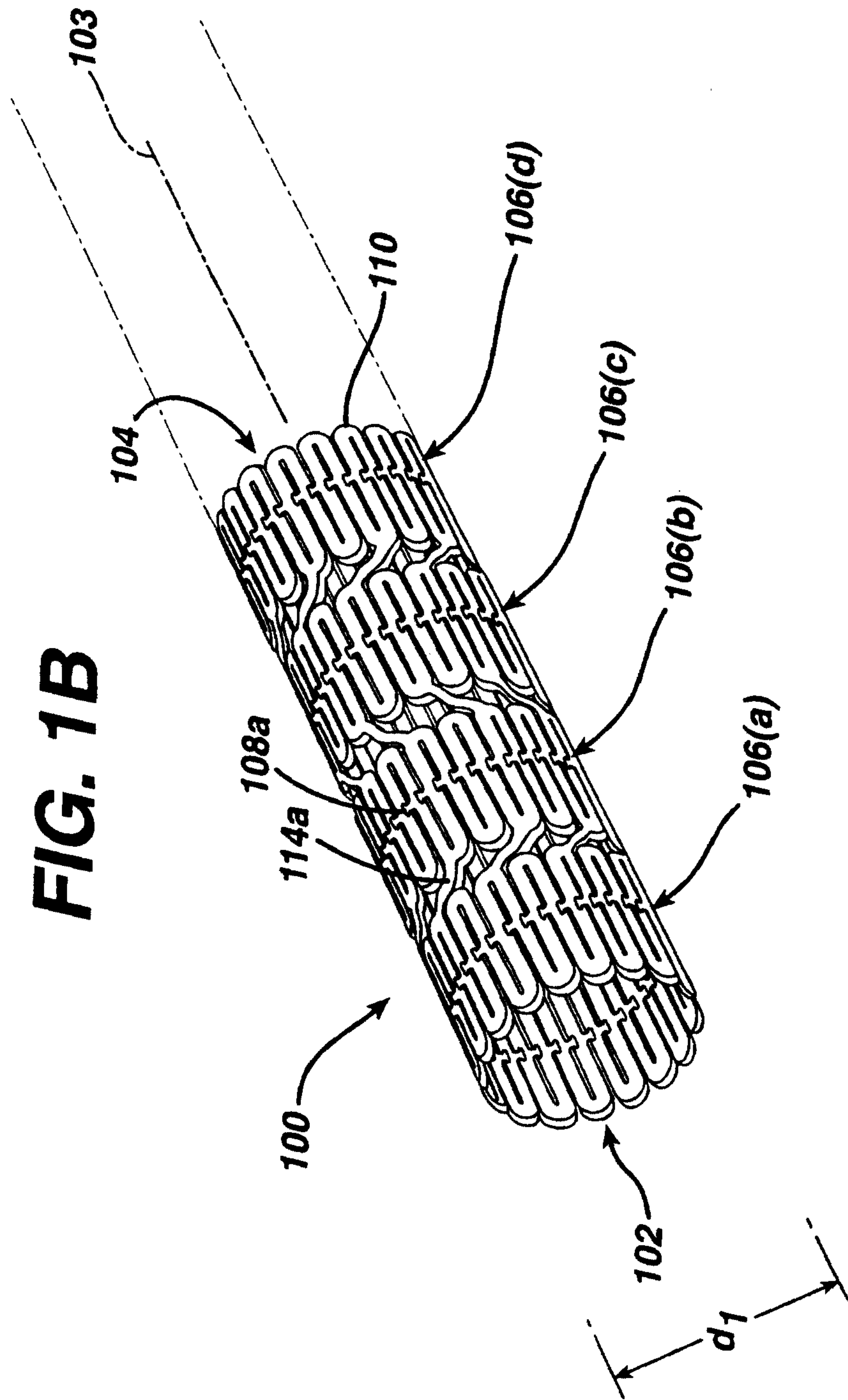

FIG. 2A

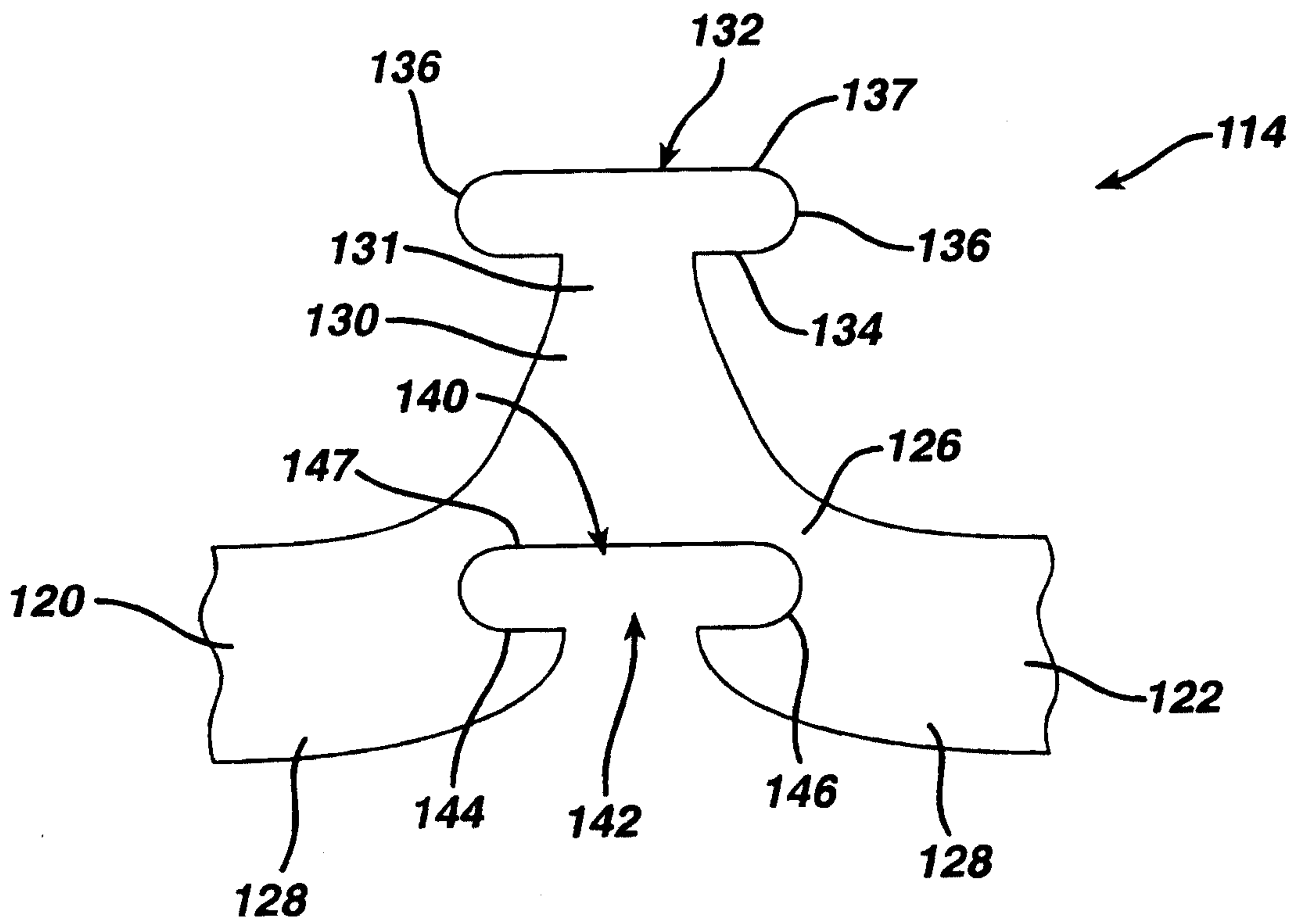

FIG. 2B

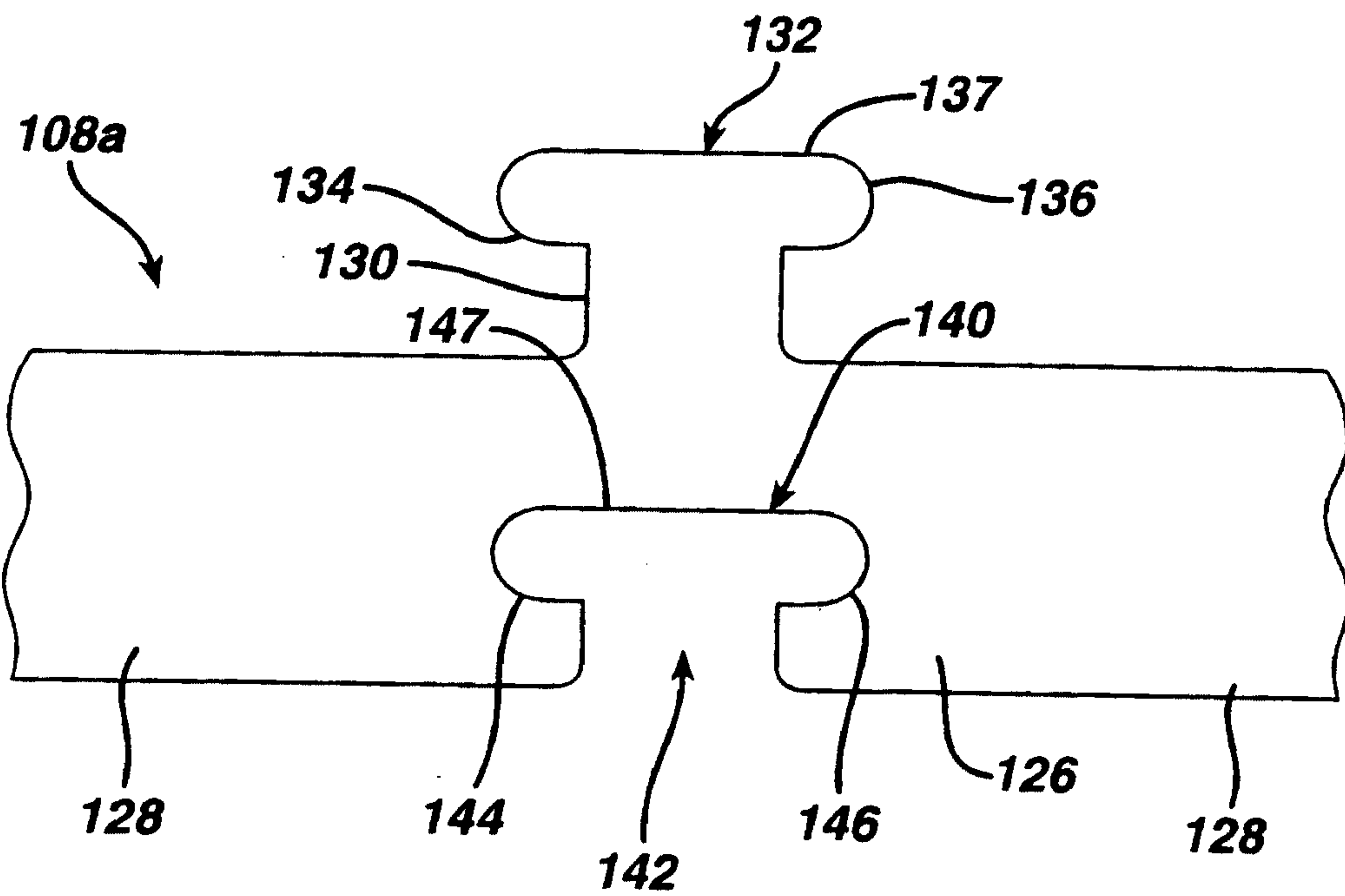

FIG. 3A

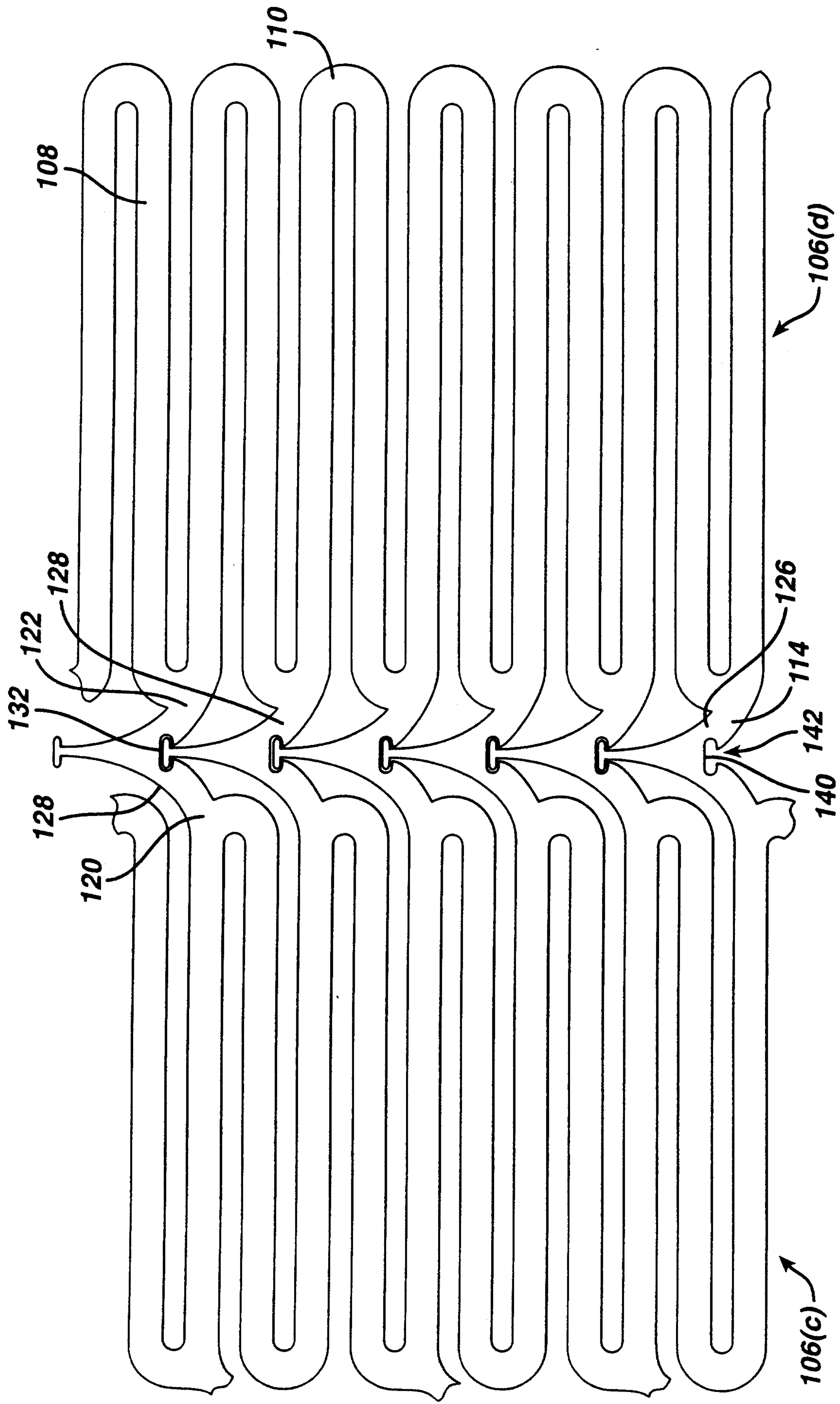

FIG. 3B

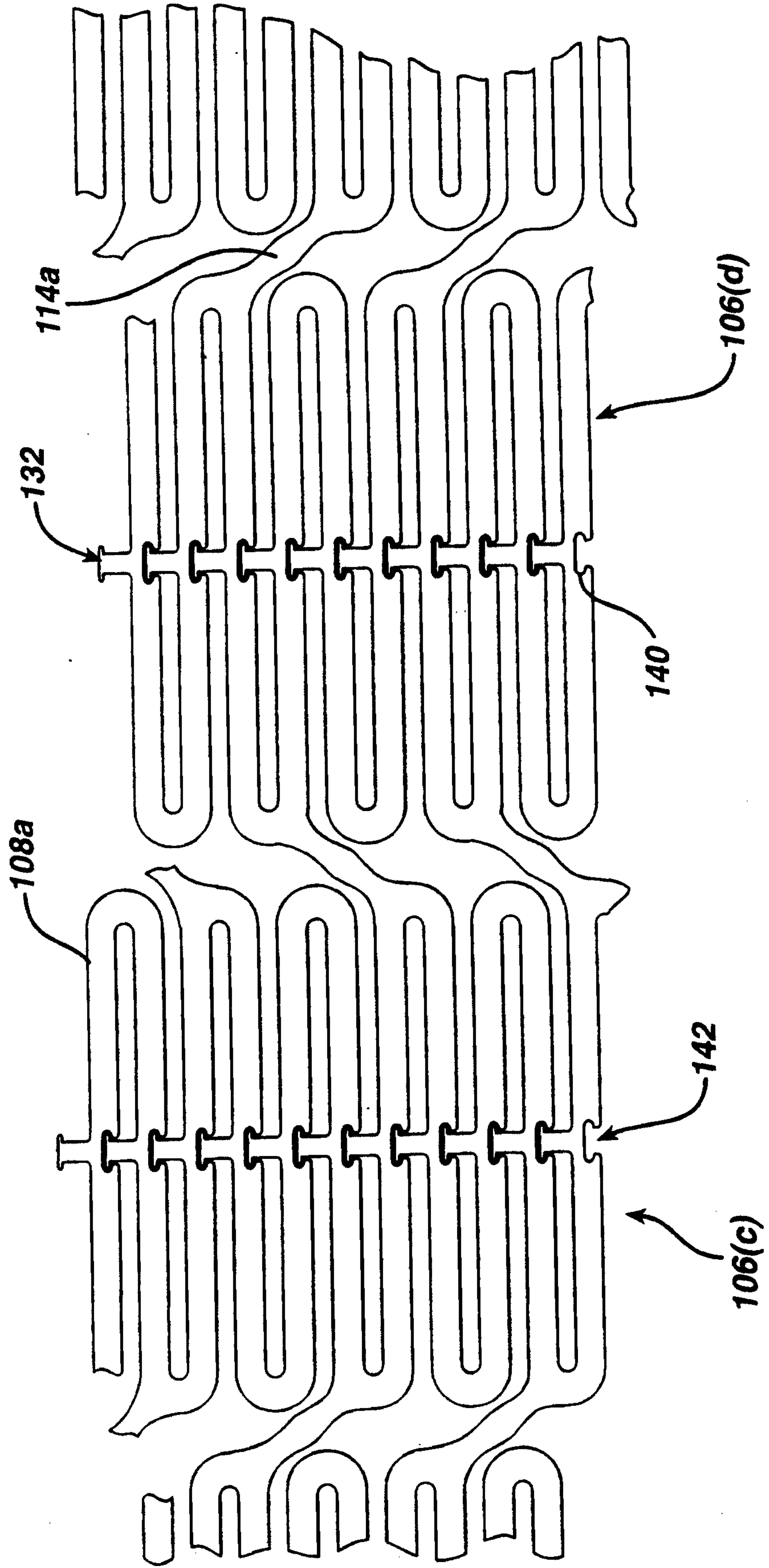

FIG. 4A

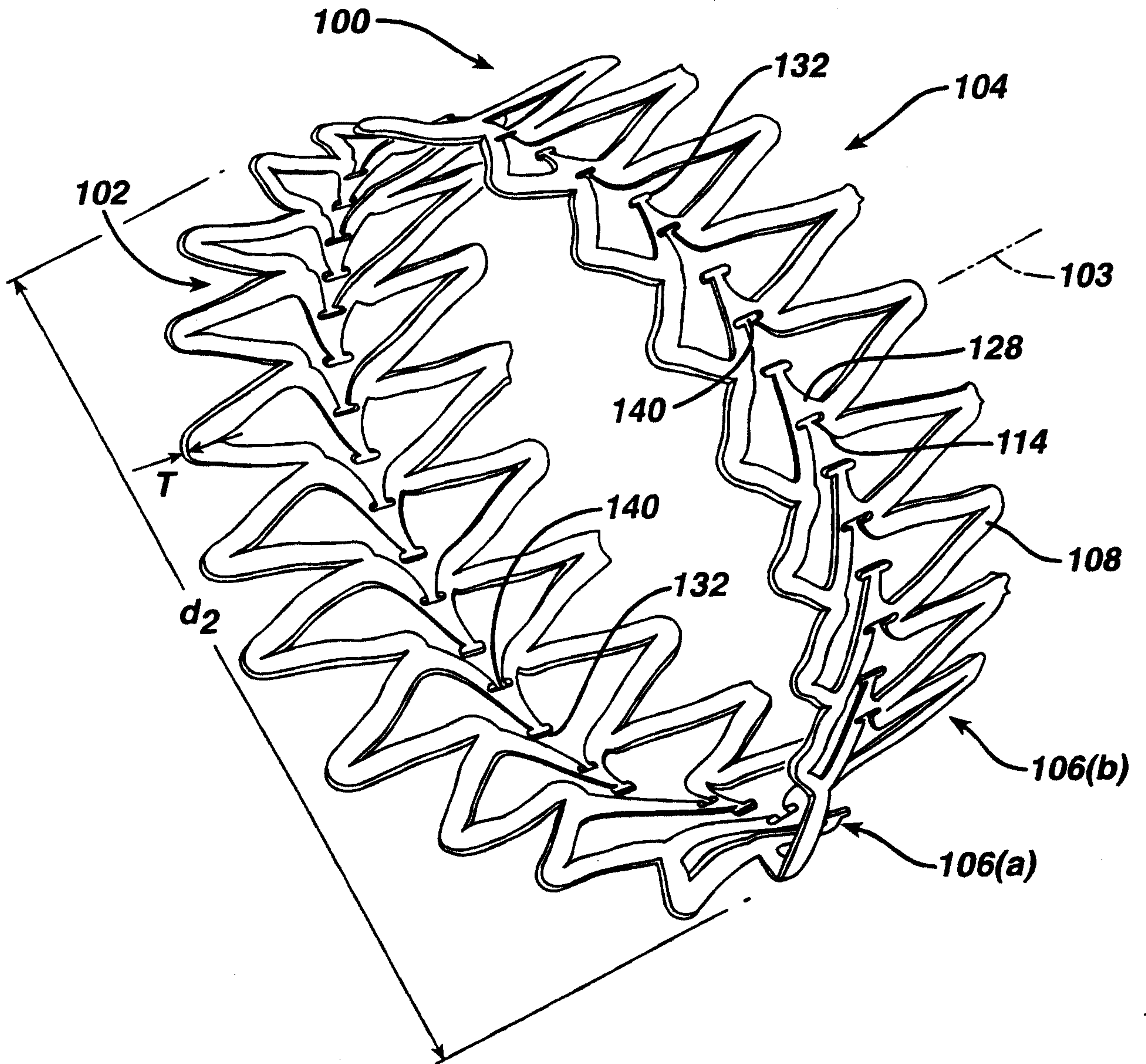
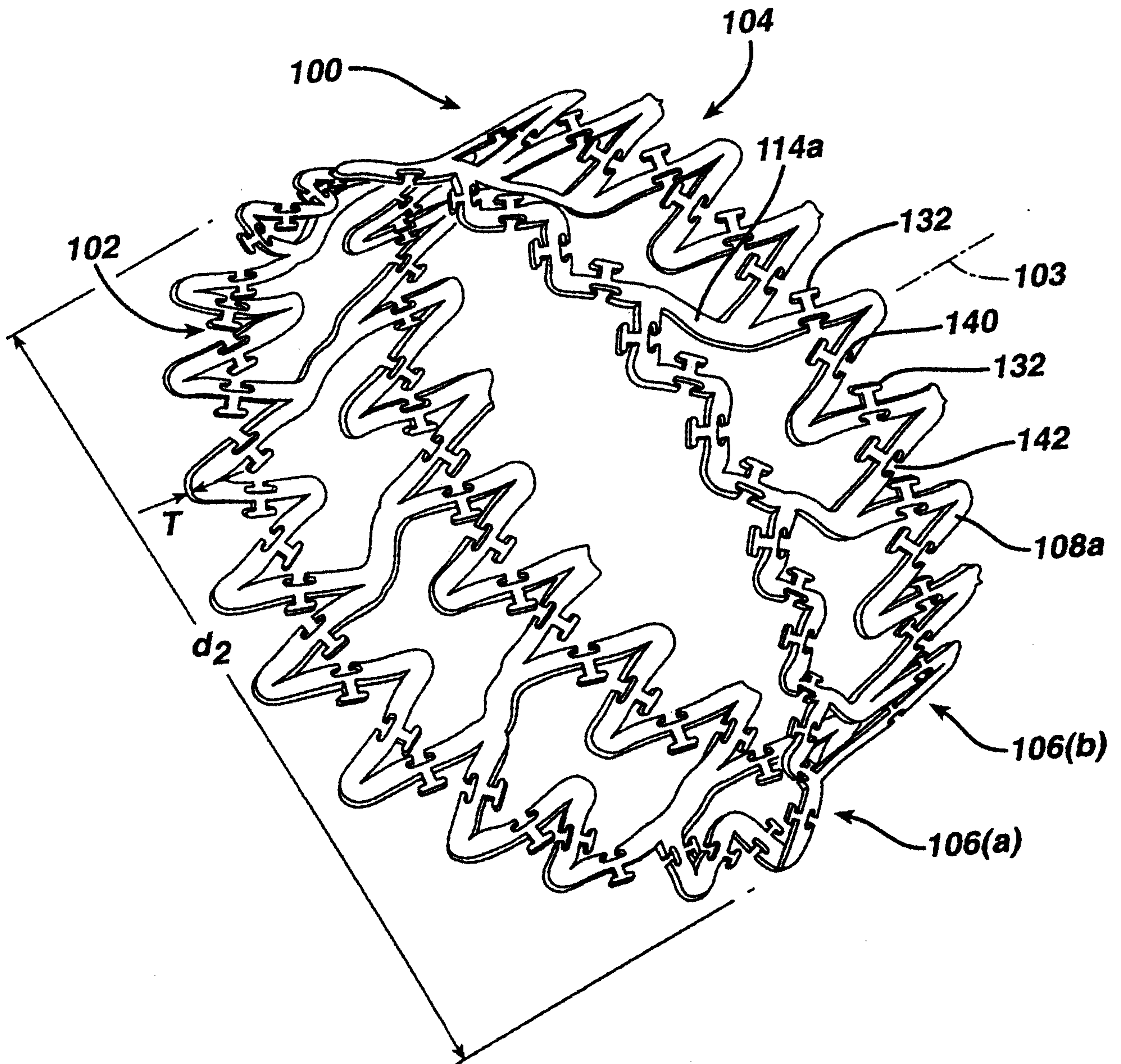

FIG. 4B



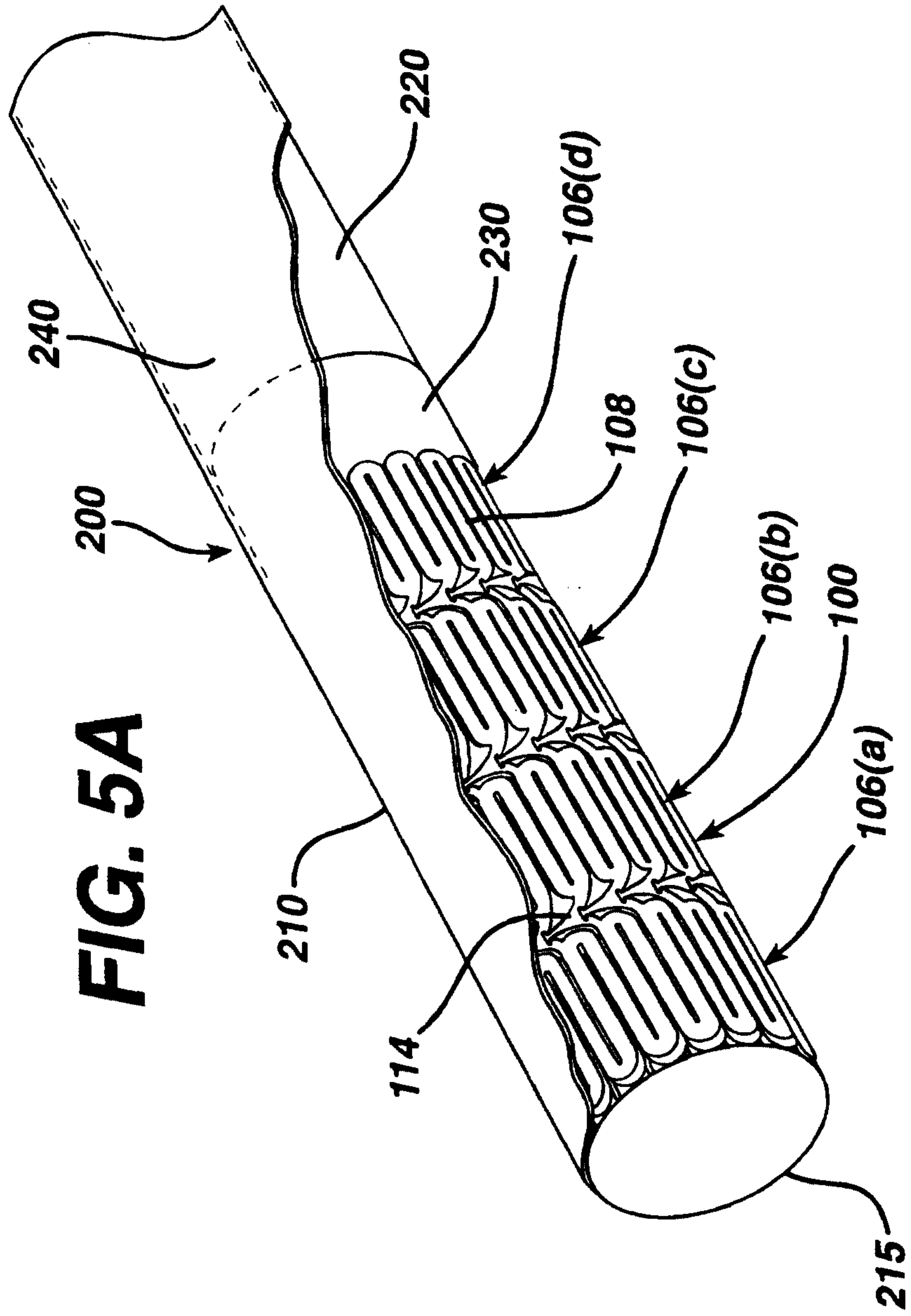

FIG. 5B

