

FASCICULE DE BREVET D'INVENTION

21 Numéro de dépôt : 1201700397
PCT/IB2016/052043

22 Date de dépôt : 11/04/2016

30 Priorité(s) :
ZA n° 2015/02400 du 10/04/2015

24 Délivré le : 26/04/2021

45 Publié le : 14/07/2021

73 Titulaire(s) :
EDEN GREEN HYDROPONICS INTERNATIONAL
(PTY) LTD.,
291 Sunderlandridge,
Kwambi Crescent,
0057 CENTURION (ZA)

72 Inventeur(s) :
VAN BUUREN, Eugene (ZA)
VAN BUUREN, Jacques (ZA)
EHLERS, Jan Gerhardus (ZA)

74 Mandataire : Cabinet NICO HALLE & CO. LAW
FIRM, 1st Floor SHALOM Building, Ancienne
Route, Opposite Pharmacie du Pont/Express
Union, B.P. 4876, DOUALA (CM).

54 Titre : Hydroponics.

57 Abrégé :

The invention relates to a planter (10) forming part of a hydroponic system. The planter (10) includes a longitudinal body (12) defining at least two longitudinally extending liquid channels (14.1, 14.2) and at least two plant holders (16, 18) defined in the body (12), the plant holders (16, 18) spaced on the outer circumference of the longitudinal body (12), each one of the at least two plant holders (16, 18) in fluid flow communication with one of the at least two longitudinally extending liquid channels (14.1, 14.2).

Fig. 3

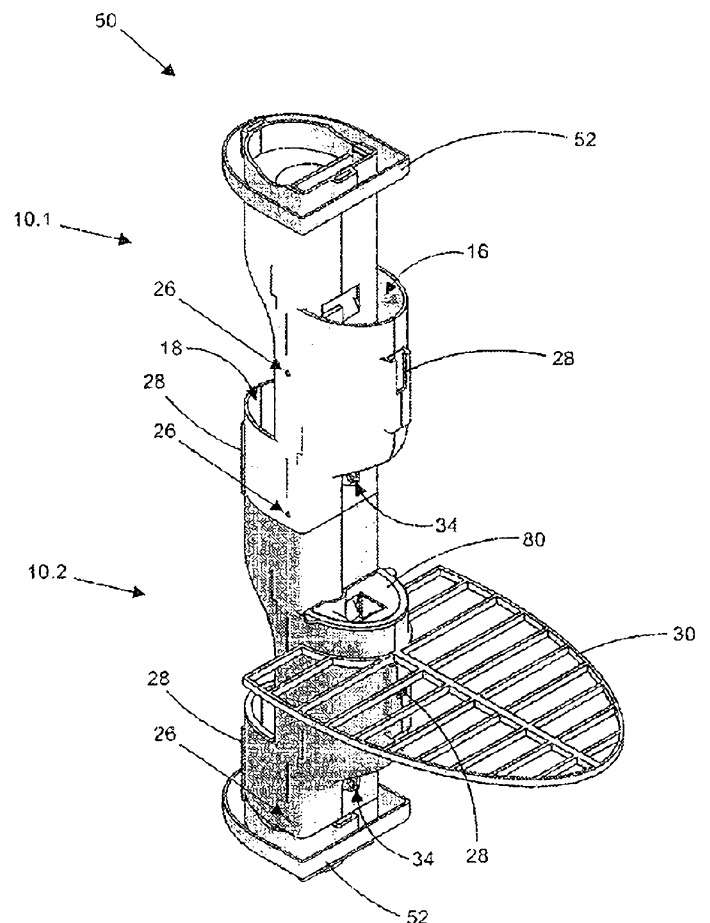

HYDROPONICS

FIELD OF INVENTION

[0001] This invention relates to hydroponics. In particular the invention relates to a planter, a planter tower and a hydroponic greenhouse

BACKGROUND OF THE INVENTION

[0002] The inventors are aware of hydroponic systems and arrangements. In particular, the inventors filed an earlier South African Patent application number 2014/02082.

[0003] Existing planters are prone to plants growing into each other and getting attached to each other in the planter, which make the harvesting of plants from the planter cumbersome.

[0004] Furthermore, the present invention has the object of improving planting density without compromising growth.

SUMMARY OF THE INVENTION

[0005] According to one aspect of the invention, there is provided a planter which includes a longitudinal body defining at least two longitudinally extending liquid channels; and at least two plant holders defined in the body, the plant holders spaced on the outer circumference of the longitudinal body, each one of the at least two plant holders in fluid flow communication with one of the at least two longitudinally extending liquid channels.

[0006] The longitudinal body may include a single longitudinal conduit which is internally divided to define the at least two longitudinally extending liquid channels.

[0007] Each planter holder may define a holder mouth into which plants are receivable. In particular the holder mouth may be shaped as an applanated cylindrical ellipse, -circle or the like.

[0008] In one embodiment, the at least two plant holders may be located on opposed sides of the longitudinal body. In particular, the at least two plant holders may be alternatively spaced on opposed sides over the length of the longitudinal body.

[0009] Each of the plant holders may be in fluid flow communication with a different one of the longitudinally extending liquid channels.

[0010] The longitudinal body may include connecting formations at the ends of the longitudinal body.

[0011] The connecting formations may be shaped and dimensioned to fit into corresponding connection formations of corresponding planters.

[0012] The operative lower end of the longitudinal body of the planter may have a connection formation for fitting into a corresponding connection formation on an operative upper end of a longitudinal body of a corresponding planter installed below the former planter, and the operative upper end of the longitudinal body of the planter may have a connection formation for fitting into a corresponding connection formation on an operative lower end of a longitudinal body of a corresponding planter installed above the former planter.

[0013] In one embodiment the connecting formations may be in the form of socket and spigot formations shaped and dimensioned to fit into respective spigot and socket formations of corresponding planters.

[0014] The operative lower end of the longitudinal body of the planter may have a spigot formation, for fitting into a socket formation on an operative upper end of a longitudinal body of a corresponding planter installed below the former planter and the operative upper end of the longitudinal body of the planter may have a socket formation for receiving a spigot formation on an operative lower end of a longitudinal body of a corresponding planter installed above the former planter.

[0015] In an opposed example, the operative lower end of the longitudinal body of the planter may have socket formation, for receiving a spigot formation on an operative upper end of a longitudinal body of a corresponding planter installed below the former planter and the operative upper end of the longitudinal body of the planter may have a spigot formation for fitting into a socket formation on an operative lower end of a longitudinal body of a corresponding planter installed above the former planter.

[0016] Each plant holder may include an inlet opening and an outlet opening, which is in flow communication with its corresponding liquid channel. In particular the inlet opening may be located above the outlet opening to permit gravitational liquid flow into the plant holder through the inlet opening and liquid flow from the plant holder through the outlet opening.

[0017] The planter may include at least one longitudinally extending gas channel, the gas channel having gas outlets spaced along its length. The gas outlets may open to the outside of the planter body. The gas outlets may be in the form of nozzles.

[0018] The connecting formations may be shaped and dimensioned to connect adjacent planter bodies together. The connecting formations may include liquid channel connecting formations for connecting the liquid channels of adjacent planter bodies together. The connecting formations may include gas channel connecting formations for connecting the gas channels of adjacent planter bodies together.

[0019] The planter may include an external attachment formation proximate the plant holder mouth for attaching plant supports. In particular, the attachment formation may be located below the plant holder mouth and may receive various types of plant supports, such as a creeper trellis and the like. In this embodiment, the creeper trellis may be arranged to support a creeper plant, planted in the plant holder when it grows from the plant holder mouth.

[0020] The external attachment formation may further be supportive of lighting means, proximate the plant leaves for enhancing lighting onto the plant and subsequent plant growth. The lighting means may be in the form of light emitting diodes (LED's) operable to emit a specific frequency of light.

[0021] The planter may further include planting inserts shaped and dimensioned to fit into mouths of the at least two plant holders.

[0022] The planting inserts may be selected from any one or more of: a seedling tray, a planting tray, a seeding clip and the like.

[0023] The seedling tray may be in the form of a cylindrical body, shaped to the shape of the plant holder. The seedling tray may have a depth of about 43mm. The seedling tray may include an inlet opening indexed with the inlet opening of the plant holder. The seedling tray may include a planar base cut in sections to provide drainage slits. The drainage slits may be less than 0.5mm in width to permit liquid drainage without flushing seedlings from the seedling tray.

[0024] The planting tray may be in the form of a cylindrical body shaped to the shape of the plant holder. The planting tray may have a depth of about 117mm. The planting tray may include an inlet opening indexed with the inlet opening of the plant holder. The planting tray may include a planar base cut in sections to provide drainage slits. A portion of the planting tray sidewall may also include drainage slits. The portion of the sidewall may be slightly tapered towards the base. The drainage slits may be less than 0.5mm in width to permit liquid drainage without flushing seedlings from the seedling tray.

[0025] The seeding clip may have a planar body for closing the planter mouth and provided with a downwardly projecting plate having a slot shaped to engage the stem of a plant.

[0026] According to another aspect of the invention, there is provided a planter tower, which includes a plurality of planters as described, connected together to form an elongate upright planter with plant holders extending from the sides of the planter tower.

[0027] The planter tower may include between eight and sixteen planters connected together.

[0028] The planter tower may include at least one end member, shaped and dimensioned to connect onto an end the plurality of planters connected together.

[0029] Specifically the planter tower may include two end members, a top end member for connecting to the top end of the plurality of planters and a bottom end member for connecting to the bottom end of the plurality of planters.

[0030] The at least one end member may be shaped to fit onto an end of a longitudinal body of a planter, socket and spigot fashion.

[0031] The at least one end member may include dual liquid conduits indexed to match the longitudinally extending liquid channels.

[0032] The at least one end member may include a gas conduit indexed to match a gas channel extending through the planters.

[0033] The at least one end member may include a body with two sides, one of which is provided with a socket formation and one of which is provided with a spigot formation for fitting onto matched spigot and socket formations of the ends of the longitudinal body.

[0034] The top end member may be in the form of an intake closure attached at a top end of a plurality of inter-connected planters for directing liquid into the two longitudinally extending liquid channels and for directing gas into the at least one longitudinally extending gas channel.

[0035] The bottom end member may be in the form of an outlet closure attached at a bottom end of a plurality of inter-connected planters for directing liquid from the two longitudinally extending liquid channels and for directing gas from the at least one longitudinally extending gas channel.

[0036] The at least one end member may include a catchment tray, for receiving any overflow liquid.

[0037] The liquid channels may extend over the length of the interconnected planters.

[0038] Each planter in the planter tower may include a gas channel, the gas channel extends over the length of the inter-connected planters.

[0039] According to another aspect of the invention, there is provided a hydroponic greenhouse, which includes an array of planter towers, the planter towers arranged in parallel spaced rows, the rows being provided with a top liquid and gas supply line, connected via an intake closure to a top of each of the planter towers, the rows further being provided with a bottom liquid and gas collection line, connected via an outlet closure to a bottom of each of the planter towers; a liquid circulation system, connected to the liquid supply lines and the liquid collection lines; a gas circulation system, connected to the gas supply lines and the gas collection lines.

[0040] In an embodiment where the gas outlets, described above, are directed to the outsides of the planter bodies, the gas outlets may be directed at plants in an adjacent planter tower, advantageously to provide an adequate exchange of gas on the leaves of an adjacent plant.

[0041] The greenhouse may include a partially closed enclosure, which may be provided with any one or more of air conditioners, high pressure fans, dampers, coiled coolers for recirculation of the liquid or gas from the liquid collection lines to the liquid supply lines or alternatively gas supply lines, geothermal heater/coolers, heat pumps, humidity controllers, infra-red controllers, and the like.

[0042] The greenhouse may be provided with a nutrient supply dosing pump connected to the liquid circulation system for dosing nutrients into the liquid circulation system.

[0043] The greenhouse may further include a filtering arrangement connected to the liquid circulation system for filtering the liquid in the liquid circulation system.

10 [0044] The invention will now be described by way of a non-limiting example only, with reference to the following drawing.

DRAWINGS

[0045] In the drawings:

15 [0046] Figure 1a and 1 b show three-dimensional views of a planter in accordance with one aspect of the invention;

[0047] Figure 2a and 2b show two halves of the planter of Figure 1 ;

[0048] Figure 3 shows a planter tower comprising assembled planters of Figure 1 ;

[0049] Figure 4a and 4b show three-dimensional views of an end member of a planter arrangement;

20 [0050] Figure 5 shows a seedling tray of a planter;

[0051] Figure 6 shows a planting tray of a planter;

[0052] Figure 7 shows a creeper trellis of a planter;

[0053] Figure 8 shows a seeding clip of a planter arrangement; and

25 [0054] Figure 9 shows a hydroponic greenhouse in accordance with a further aspect of the invention.

EMBODIMENT OF THE INVENTION

[0055] In Figure 1 a planter 10, in accordance with one aspect of the invention, is shown. The planter 10 has a longitudinal body 12, in two halves 12.1 and 12.2, as best shown in Figures 2a and 2b.

30 [0056] The longitudinal body 12 defines two longitudinally extending liquid channels 14.1 and 14.2 as shown in Figure 1 and 2.

[0057] The planter 10 includes two plant holders 16, 18 defined on the outer circumference of the longitudinal body. As can be seen in Figure 2, the two plant holders 16, 18 have openings 16.1, 18.1 defining liquid inlets to the plant holders and 16.2, 18.2 defining liquid outlets from the plant holders.

5 [0058] As can be seen in Figures 1 and 2, the plant holders 16, 18 have holder mouths in the form of applanated cylindrical ellipses.

[0059] As can be seen in Figures 1 and 2, the two plant holders 16, 18 are alternatively spaced on opposed sides of the longitudinal body.

10 [0060] In Figure 1 and 2, it can be seen that the longitudinal body has connecting formations 20, 22 in the form of socket and spigot formations at the ends of the longitudinal body 12. As can be seen in Figure 3, the connecting formations are shaped and dimensioned to fit into respective spigot and socket formations of corresponding planters.

[0061] Importantly the operative lower end of the longitudinal body 12 of the planter 10 has a spigot formation 22, for fitting into a socket formation 20 on an operative upper end of a longitudinal body 12 of a corresponding planter 10 installed below the former planter.

15 [0062] As can be seen in Figure 2, each plant holder 16, 18 has an inlet opening 16.1, 18.1 and an outlet opening 16.2, 18.2, respectively, which forms part of its corresponding liquid channel 14.2 and 14.1, respectively. As can be seen, the inlet openings 16.1, 18.1 are located above the outlet openings 16.2, 18.2 to permit liquid to flow into the plant holders 16, 18 through the inlet openings 20 16.1, 18.1 and from the plant holder through the outlet opening 16.2, 18.2.

[0063] As can be seen in Figure 2, each plant holder 18 comprises two halves, which defines a complete plant holder, when connected to each other.

25 [0064] The planter 10 further includes a longitudinally extending gas channel 24. The gas channel 24 has outlets spaced along its length. In particular, the gas channel 24 has outlets 26 that open to the outside of the planter body 12 (see Figure 3). The gas outlets 26 are in the form of nozzles, when the planters are assembled in an array as shown in Figure 9, the nozzles are directed at plants in adjacent planter towers, to ensure adequate gas exchange on the leaves of those plants.

30 [0065] As can be seen in Figure 1, the planter has an external attachment formation 28 proximate the plant holder mouth for attaching plant supports. One example of such a plant support is a plant trellis 30, shown in Figure 7, which has a corresponding attachment formation 32, which can fit into the attachment formation 28, spigot and socket fashion. The creeper trellis 30 is arranged to support a creeper plant (not shown), planted in the plant holder when it grows from the plant holder mouth 16, 18.

[0066] The planter 10 also has external attachment formations in the form of apertures 34, for holding wire, line or cables that can provide additional structural strength to the planter assembly 50 or to provide a structure onto which creepers can grow.

[0067] Each planter 10 also includes planting inserts (as shown in Figure 5, 6 and 8) shaped and dimensioned to fit onto mouths of the plant holders 16, 18. The planting inserts are selected from: a seedling tray, a planting tray and a seeding clip. The planting inserts may be selected based on its suitability for a specific plant.

[0068] In Figure 5 a seedling tray 60 is shown, which is shaped and dimensioned to fit into a mouth of a plant holder 16, 18. The seedling tray 60 has a depth of about 43mm. The seedling tray 60 has an inlet opening 60.1 indexed with the inlet openings 16.1, 18.1 of the plant holder. The seedling tray 60 has a planar base cut in sections to provide drainage slits 60.2. The drainage slits 60.2 are less than 0.5mm in width to permit liquid drainage without flushing seedlings from the seedling tray 60.

[0069] In Figure 6 a planting tray 70 is shown, which is shaped and dimensioned to fit into a mouth of a plant holder 16, 18. The planting tray 70 has a depth of about 117mm and is in the form of a cylindrical body shaped to the shape of the plant holder 16, 18. The planting tray 70 includes an inlet opening 70.1 indexed with the inlet openings of the plant holder 16.1, 18.1. The planting tray 70 has a planar base cut in sections to provide drainage slits. A portion of the planting tray sidewall also has drainage slits 70.2. The portion of the sidewall is slightly tapered towards the base. The drainage slits is less than 0.5mm in width to permit liquid drainage without flushing seedlings from the seedling tray 70.

[0070] In Figure 8 a seeding clip 80 is shown. The seeding clip 80 is shaped to fit onto the mouth of a plant holder 16, 18. The seeding clip 80 has a planar body for closing the planter mouth and is provided with a downwardly projecting plate 80.2 and a slot 80.3 shaped to engage the stem of a plant. The seeding clip 80 further includes finger projections 80.1, which can be compressed towards each other for removing the seeding clip 8 from the mouth of the plant holder 16, 18.

[0071] Figure 3 shows a planter tower 50 in accordance with a further aspect of the invention. In this example the planter tower 50 includes two planters 10.1, 10.2 as described, connected together to form an elongate upright planter, with plant holders 16, 18 extending from the sides of the planter tower 50 (It is to be appreciated that in a preferred embodiment a planter tower would include about eight planters connected together as shown in Figure 9).

[0072] The planter tower 50 is provided with two end members 52, as best shown in Figure 4, (not mounted in Figure 4) shaped to fit socket and spigot fashion onto a top or bottom end of a longitudinal body 12 of a planter 10.

[0073] The end members 52 have dual liquid conduits 54, 56 indexed to match the longitudinally extending liquid channels 14.2, 14.1. The end members 52 also each has a gas conduit 58 indexed to match the gas channel 24 extending through the planters.

[0074] The end members 52 each has a body with two sides, an upper side which is provided with a socket formation 52.1 and a bottom side which is provided with a spigot formation 52.2 for fitting onto matched spigot- 22 and socket- 20 formations on the ends of the longitudinal body 12 of the planters 10. The upper and bottom sides further includes a recessed cradle formation for receiving a top liquid and gas supply line (as shown in Figure 9) and a bottom liquid and gas collection line across the end members. In this example the upper cradle formation is dimensioned to fit a 50mm to 65mm pipe and the bottom cradle formation is dimensioned to fit a 110mm to 160mm pipe.

[0075] In this example the planter tower 50 includes a top end member 52 for connecting to the top end of the plurality of planters 10.1, 10.2 and a bottom end member 52 for connecting to the bottom end of the plurality of planters 10.1, 10.2. The top end member 52 and bottom end member 52 are identical in shape and dimension, but function as an intake closure 52 and outlet closure 52 respectively.

[0076] The intake closure 52 attached at a top end of a plurality of interconnected planters, being operable to direct liquid into the two longitudinally extending liquid channels 14.1, 14.2 and for directing gas into the longitudinally extending gas channel 24.

[0077] The outlet closure 52 attached at a bottom end of a plurality of interconnected planters, being operable to direct liquid out from the two longitudinally extending liquid channels 14.1, 14.2.

[0078] The liquid channels 14.1, 14.2 and gas channel 24 extend over the length of the interconnected planters 10.

[0079] The bottom side of the end members 52 also includes a catchment tray 57 on the outer perimeter of the end members. When the end member 52 is used as a bottom end member, the catchment tray 57 is operable to receive overflow liquid from the planter tower 50.

[0080] As can be seen in Figure 3, the plant holders 16, 18 which are alternatively spaced on opposed sides over the length of the of the planter tower 50, provide for maximum space and access to sunlight for the plants. Furthermore, with the roots growing downwardly, possibly into the liquid

channels 14.1, 14.2, maximum provision is made for root growth, without interference from plants directly below or above any planter.

[0081] Figure 9 shows a hydroponic greenhouse 100 in accordance with yet a further aspect of the invention. The hydroponic greenhouse 100 includes an array of planter towers as described. In this figure only one row of planter towers 50.1 to 50.10 are shown (for illustrative purposes), however in practice the hydroponic greenhouse includes a plurality of parallel spaced planter tower rows.

[0082] The rows being provided with a top liquid and gas supply line 102, connected via an intake closure 52 to a top of each of the planter towers 50. The rows are further provided with a bottom liquid and gas collection line 103, connected via an outlet closure 52 to a bottom of each of the planter towers 50.

[0083] The hydroponic greenhouse 100 includes a liquid circulation system (not shown), connected to the liquid supply lines 102 and the liquid collection lines 103 and a gas circulation system (not shown), connected to the gas supply lines 102 and the gas collection lines 103.

[0084] In this example the top liquid and gas supply line 102 includes a 50 mm to 65mm diameter plastic outer pipe, onto which the top end members 52 of each planter tower 50 in the row is attached. The 50 mm to 65 mm diameter plastic outer pipe includes interspaced apertures through which liquid and gas is fed into the planter towers 50. The top end members (inlet closures) 52 are secured to the pipe via connectors. In this example the connectors are in the form of cable ties (not shown), which are threaded through connector apertures 59 on the end members 52.

[0085] In this example the bottom liquid and gas collection line 103 includes a 110mm to 160mm diameter plastic outer pipe, onto which the bottom end members (outlet closures) 52 of each planter tower 50 in the row is attached. The 110mm to 160mm diameter plastic outer pipe includes interspaced apertures through which liquid and gas is received from the planter towers 50. The bottom end members 52 are secured to the pipe via connectors. In this example the connectors are in the form of cable ties (not shown), which are threaded through connector apertures 59 on the end members 52.

[0086] The hydroponic greenhouse includes a partially closed enclosure (not shown), which is provided with any one or more of: air conditioners, high pressure fans, dampers, coiled coolers for recirculation of the liquid or gas from the liquid collection lines to the liquid supply lines or alternatively gas supply lines, geothermal heater/coolers, heat pumps, humidity controllers and infra-red controllers.

[0087] The hydroponic greenhouse is also provided with a nutrient supply dosing pump (not shown) connected to the liquid circulation system for dosing nutrients into the liquid circulation system.

[0088] The hydroponic greenhouse is further provided with a filtering arrangement (not shown) connected to the liquid circulation system for filtering the liquid in the liquid circulation system.

[0089] The inventors are of the opinion that the invention as described provides a new planter, a planter tower and a hydroponic greenhouse.

CLAIMS

1. A planter which includes
a longitudinal body defining at least two longitudinally extending liquid channels; and
at least two plant holders defined in the body, the plant holders spaced on the outer
5 circumference of the longitudinal body, each one of the at least two plant holders in
fluid flow communication with one of the at least two longitudinally extending liquid
channels.
2. The planter as claimed in claim 1, in which the longitudinal body includes a longitudinal
10 conduit which is internally divided to define the at least two longitudinally extending liquid
channels.
3. The planter as claimed in claim 1, in which each plant holder defines a holder mouth into
which a plant is receivable.
4. The planter as claimed in claim 3, in which the holder mouth is shaped as any one of an
applanated cylindrical ellipse and -circle.
- 15 5. The planter as claimed in claim 1, in which the at least two plant holders are located on
opposed sides of the longitudinal body.
6. The planter as claimed in claim 1, in which the at least two plant holders are alternatively
spaced on opposed sides over the length of the longitudinal body.
7. The planter as claimed in claim 1, in which each of the plant holders are in fluid flow
20 communication with a different one of the longitudinally extending liquid channels.
8. The planter as claimed in claim 1, in which the longitudinal body includes connecting
formations at the ends of the longitudinal body.
9. The planter as claimed in claim 8, in which the connecting formations are shaped and
dimensioned to fit into corresponding connection formations of corresponding planters.
- 25 10. The planter as claimed in claim 9, in which the operative lower end of the longitudinal body
of the planter has a connection formation for fitting into a corresponding connection formation on an
operative upper end of a longitudinal body of a corresponding planter installed below the former

planter, and in which the operative upper end of the longitudinal body of the planter has a connection formation for fitting into a corresponding connection formation on an operative lower end of a longitudinal body of a corresponding planter installed above the former planter.

11. The planter as claimed in claim 9, in which the connecting formations are in the form of
5 socket and spigot formations shaped and dimensioned to fit into respective spigot and socket formations of corresponding planters.

12. The planter as claimed in claim 10, in which the operative lower end of the longitudinal body
of the planter has a spigot formation, for fitting into a socket formation on an operative upper end of
a longitudinal body of a corresponding planter installed below the former planter and in which the
10 operative upper end of the longitudinal body of the planter has a socket formation for receiving a
spigot formation on an operative lower end of a longitudinal body of a corresponding planter
installed above the former planter.

13. The planter as claimed in claim 10, in which the operative lower end of the longitudinal body
of the planter has a socket formation, for receiving a spigot formation on an operative upper end of a
15 longitudinal body of a corresponding planter installed below the former planter and in which the
operative upper end of the longitudinal body of the planter has a spigot formation for fitting into a
socket formation on an operative lower end of a longitudinal body of a corresponding planter
installed above the former planter.

14. The planter as claimed in claim 1, in which each plant holder includes an inlet opening and
20 an outlet opening, which is in flow communication with its corresponding liquid channel.

15. The planter as claimed in claim 14, in which the inlet opening is located above the outlet
opening to permit gravitational liquid flow into the plant holder through the inlet opening and liquid
flow from the plant holder through the outlet opening.

16. The planter as claimed in claim 1, in which the planter includes at least one longitudinally
25 extending gas channel, the gas channel having gas outlets spaced along its length.

17. The planter as claimed in claim 16, in which the gas outlets open to the outside of the planter
body.

18. The planter as claimed in claim 17, in which the gas outlets are in the form of nozzles.

19. The planter as claimed in claim 8, in which the connecting formations includes liquid channel connecting formations for connecting the liquid channels of adjacent planter bodies together.
20. The planter as claimed in claim 8, in which the connecting formations include gas channel
5 connecting formations for connecting the gas channels of adjacent planter bodies together.
21. The planter as claimed in claim 1, in which the planter includes an external attachment formation associated with each plant holder for attaching a plant support.
22. The planter as claimed in claim 21, in which the attachment formation is located below the plant holder mouth.
- 10 23. The planter as claimed in claim 21, in which the plant support is in the form of a creeper trellis arranged to support a creeper plant, planted in the plant holder when it grows from the plant holder mouth.
24. The planter as claimed in claim 1, which includes planting inserts shaped and dimensioned to fit into mouths of the at least two plant holders.
- 15 25. The planter as claimed in claim 24, in which the planting inserts are selected from any one or more of: a seedling tray, a planting tray and a seeding clip.
26. The planter as claimed in claim 25, in which the seedling tray is in the form of a cylindrical body, shaped to the shape of the plant holder and includes an inlet opening indexed with the inlet opening of the plant holder, the seedling tray includes a planar base cut in sections to provide
20 drainage slits to permit liquid drainage without flushing seedlings from the seedling tray.
27. The planter as claimed in claim 25, in which the planting tray is in the form of a cylindrical body shaped to the shape of the plant holder and includes an inlet opening indexed with the inlet opening of the plant holder, the planting tray includes a planar base cut in sections to provide drainage slits to permit liquid drainage without flushing seedlings from the seedling tray.
- 25 28. The planter as claimed in claim 27, in which a portion of the planting tray sidewall also includes drainage slits.

29. The planter as claimed in claim 27, in which a portion of the sidewall is slightly tapered towards the base.
30. The planter as claimed in claim 25, in which the seeding clip has a planar body for closing the planter mouth and provided with a downwardly projecting plate having a slot shaped to engage
5 the stem of a plant.
31. A planter tower, which includes
a plurality of planters as claimed in any one or more of claims 1 to 30, connected together to
form an elongate upright planter with plant holders extending from the sides of the
planter tower.
- 10 32. The planter tower as claimed in claim 31, in which the plant holders are alternatively spaced
on opposed sides over the length of the longitudinal bodies being connected together.
33. The planter tower as claimed in claim 31, which includes at least one end member, shaped
and dimensioned to connect onto an end of the plurality of planters connected together.
34. The planter tower as claimed in claim 33, in which the planter tower includes two end
15 members, a top end member for connecting to the top end of the plurality of planters and a bottom
end member for connecting to the bottom end of the plurality of planters.
35. The planter tower as claimed in claim 33, in which the at least one end member is shaped to
fit onto an end of a longitudinal body of a planter, socket and spigot fashion.
36. The planter tower as claimed in claim 33, in which the at least one end member includes dual
20 liquid conduits indexed to match the longitudinally extending liquid channels.
37. The planter tower as claimed in claim 33, in which the at least one end member includes a
gas conduit indexed to match a gas channel extending through the planters.
38. The planter tower as claimed in claim 35, in which the at least one end member includes a
body with two sides, one of which is provided with a socket formation and one of which is provided
25 with a spigot formation for fitting onto matched spigot and socket formations of the ends of the
longitudinal body.

39. The planter tower as claimed in claim 34, in which the top end member is in the form of an intake closure attached at a top end of a plurality of inter-connected planters for directing liquid into the two longitudinally extending liquid channels and for directing gas into the at least one longitudinally extending gas channel.
- 5 40. The planter tower as claimed in claim 34, in which the bottom end member is in the form of an outlet closure attached at a bottom end of a plurality of inter-connected planters for directing liquid from the two longitudinally extending liquid channels and for directing gas from the at least one longitudinally extending gas channel.
- 10 41. The planter tower as claimed in claim 33, in which the at least one end member includes a catchment tray, for receiving any overflow liquid.
42. The planter tower as claimed in claim 36, in which the liquid channels extend over the length of the inter-connected planters.
43. The planter tower as claimed in claim 31, in which each planter includes a gas channel, the gas channel extends over the length of the interconnected planters.
- 15 44. A hydroponic greenhouse, which includes
an array of planter towers as claimed in any one or more of claims 31 to 43, the planter
towers arranged in parallel spaced rows, the rows being provided with a top liquid
and gas supply line, connected via an intake closure to a top of each of the planter
towers, the rows further being provided with a bottom liquid and gas collection line,
20 connected via an outlet closure to a bottom of each of the planter towers;
a liquid circulation system, connected to the liquid supply lines and the liquid collection
lines; and
a gas circulation system, connected to the gas supply lines and the gas collection lines.
- 25 45. A hydroponic greenhouse as claimed in claim 44, in which gas outlets of the planters, are directed to the outsides of the planter bodies, the gas outlets being directed at plants in an adjacent planter tower, advantageously to provide an adequate exchange of gas on the leaves of the plants.
46. The hydroponic greenhouse as claimed in claim 44, in which the greenhouse includes a partially closed enclosure, which is provided with any one or more of: air conditioners, high pressure fans, dampers, coiled coolers for recirculation of the liquid or gas from the liquid collection

lines to the liquid supply lines or alternatively gas supply lines, geothermal heater/coolers, heat pumps, humidity controllers and infra-red controllers.

47. The hydroponic greenhouse as claimed in claim 44, in which the greenhouse is provided with a nutrient supply dosing pump connected to the liquid circulation system for dosing nutrients
5 into the liquid circulation system.

48. The hydroponic greenhouse as claimed in claim 44, in which the greenhouse is provided with a filtering arrangement connected to the liquid circulation system for filtering the liquid in the liquid circulation system.

49. The planter as claimed in claim 1, substantially as herein described and illustrated.

10 50. The planter tower as claimed in claim 31, substantially as herein described and illustrated.

51 The hydroponic greenhouse as claimed in claim 44, substantially as herein described and illustrated.

52. A new planter, a new planter tower and a new hydroponic greenhouse, substantially as herein described.

15

Fig 1b

Fig 1a

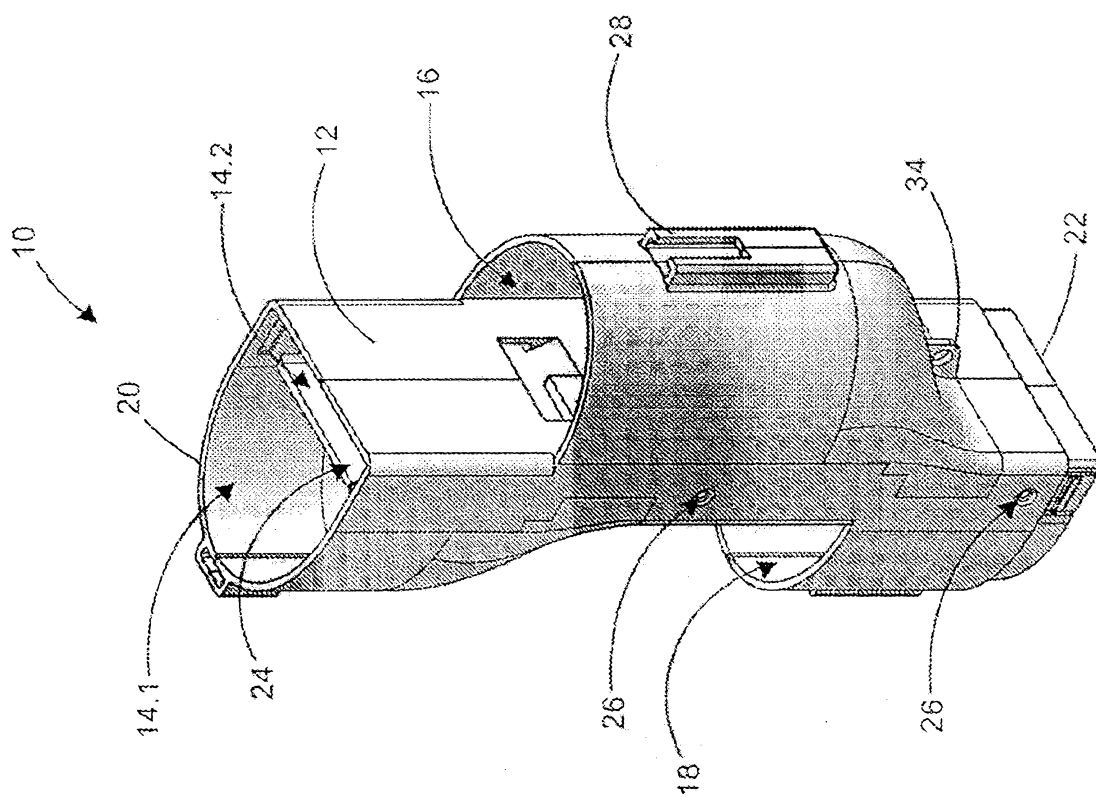
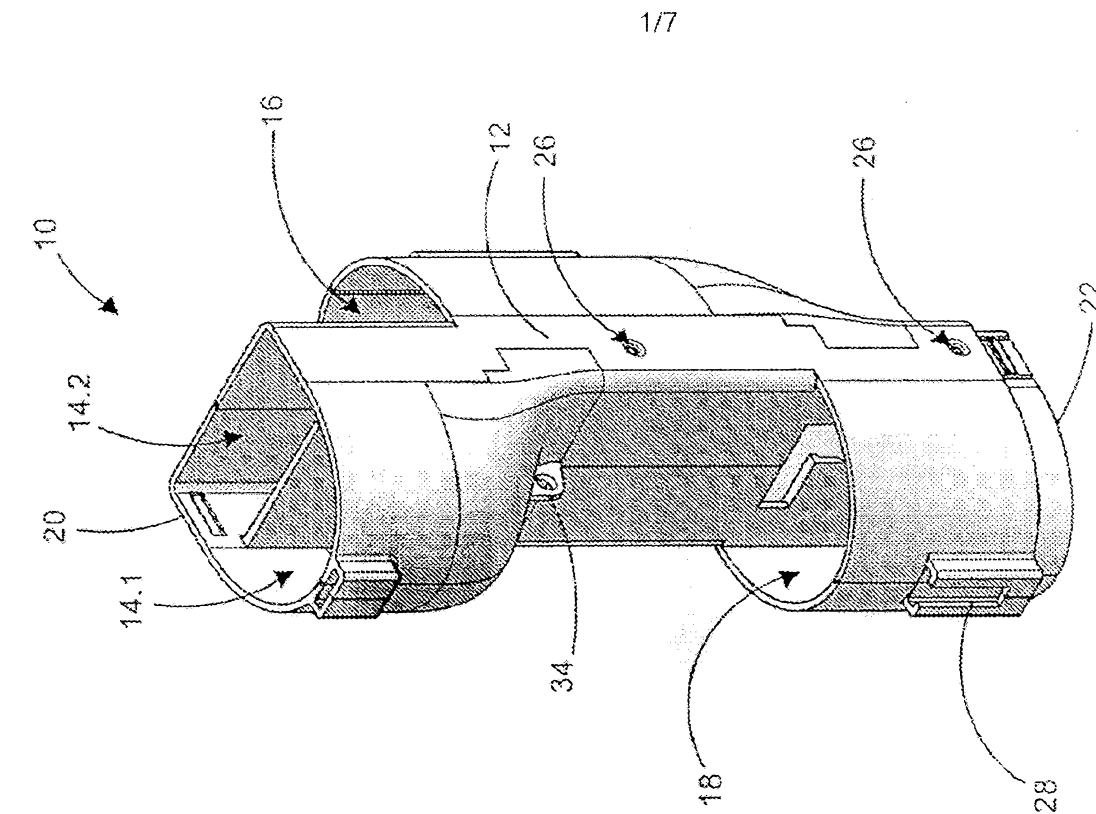

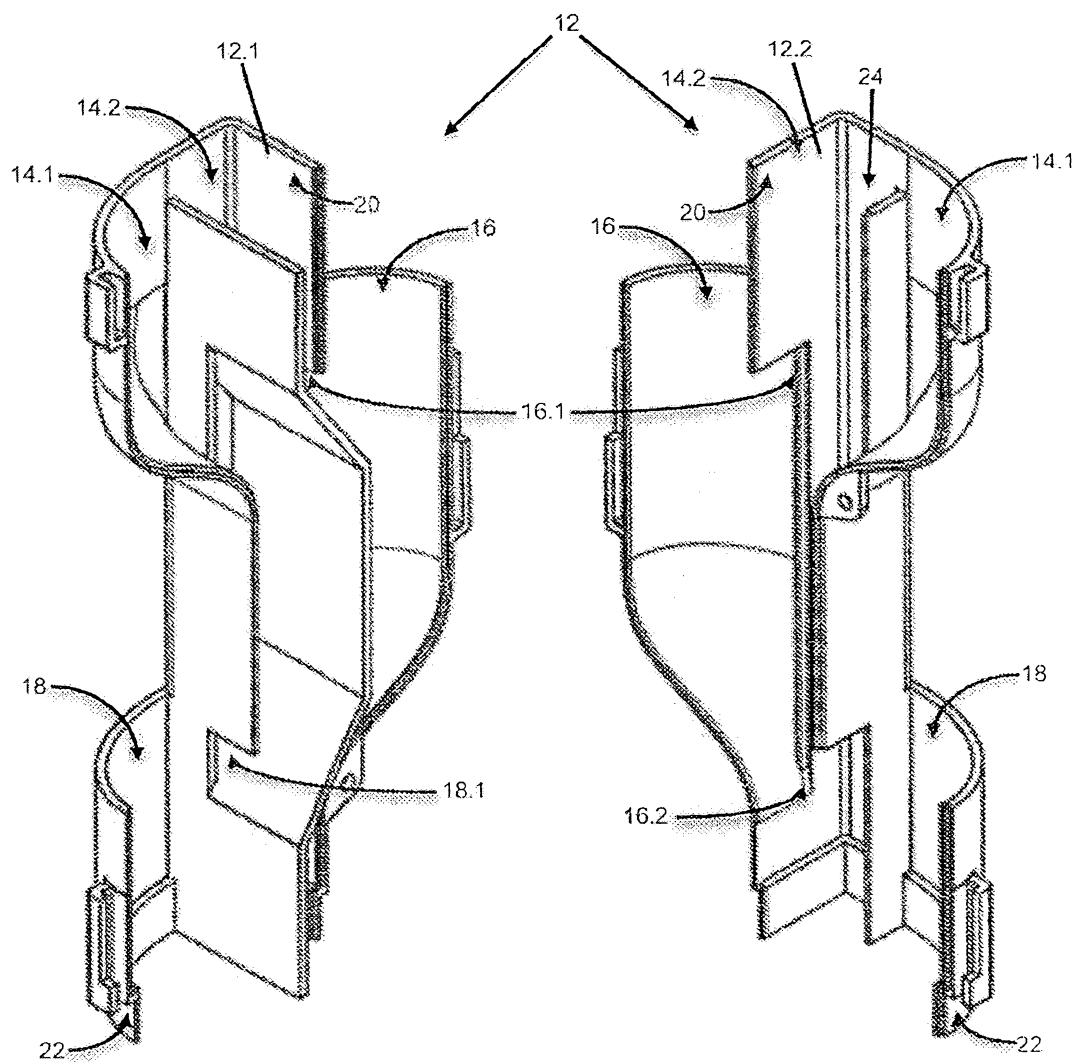

Fig. 2a

Fig. 2b

3/7

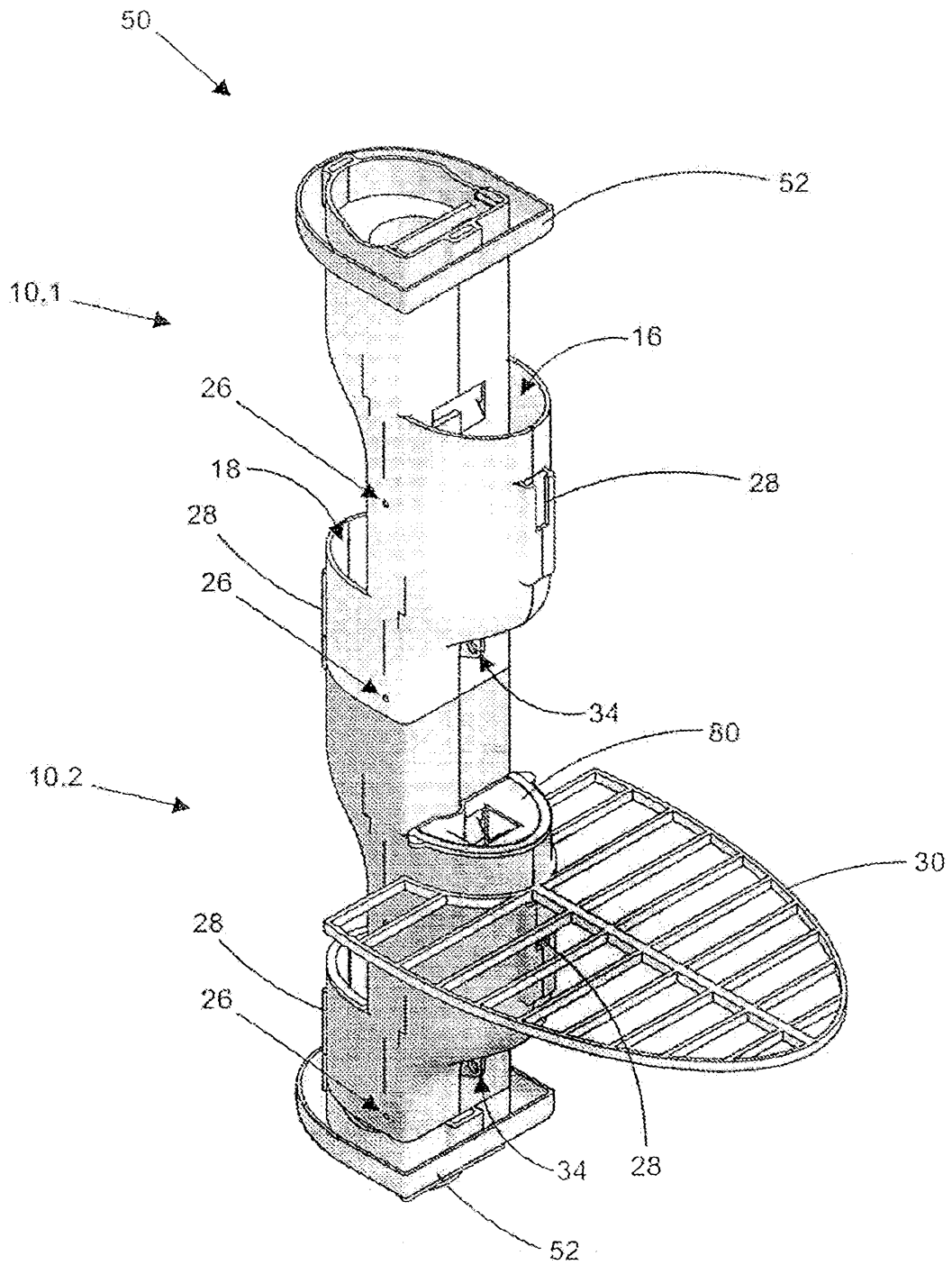

Fig 3

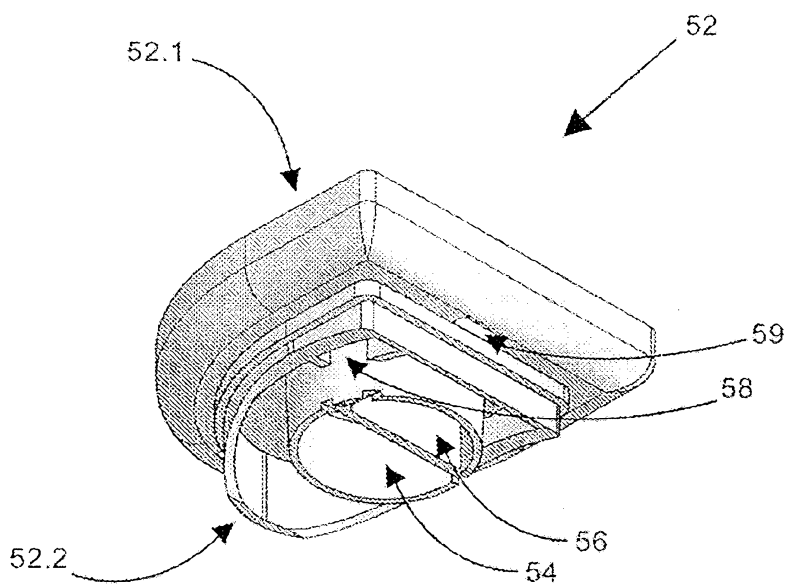

Fig 4a

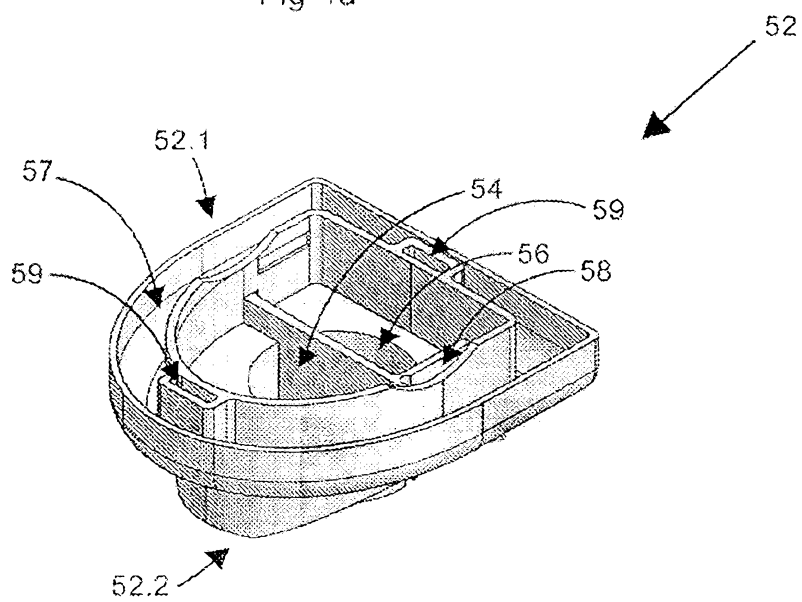
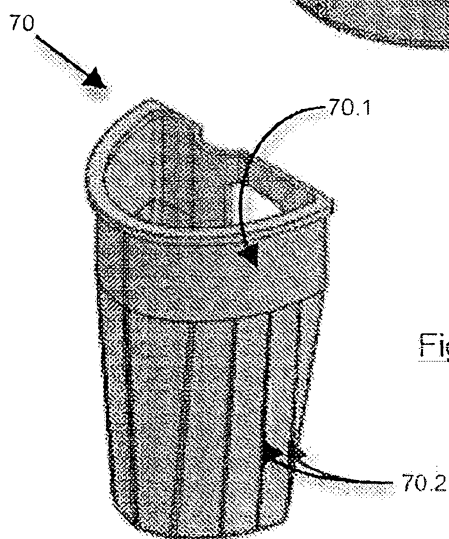
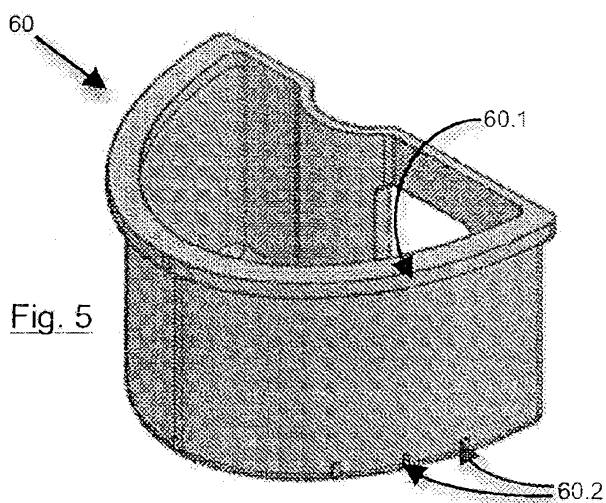

Fig 4b



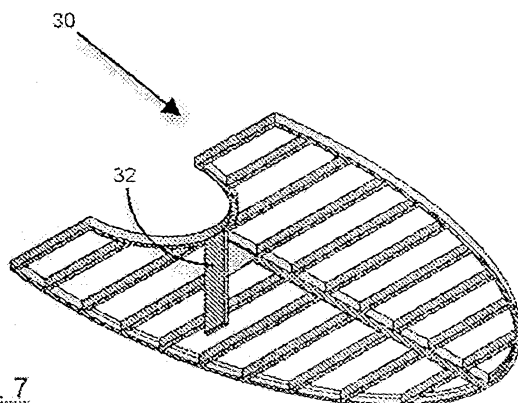

Fig. 7

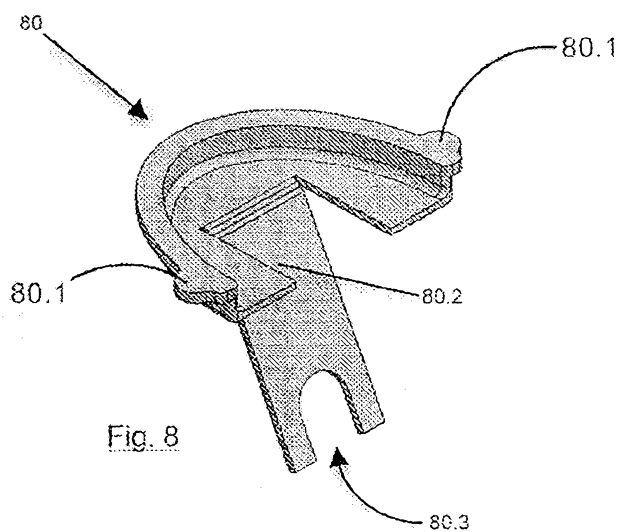

Fig. 8

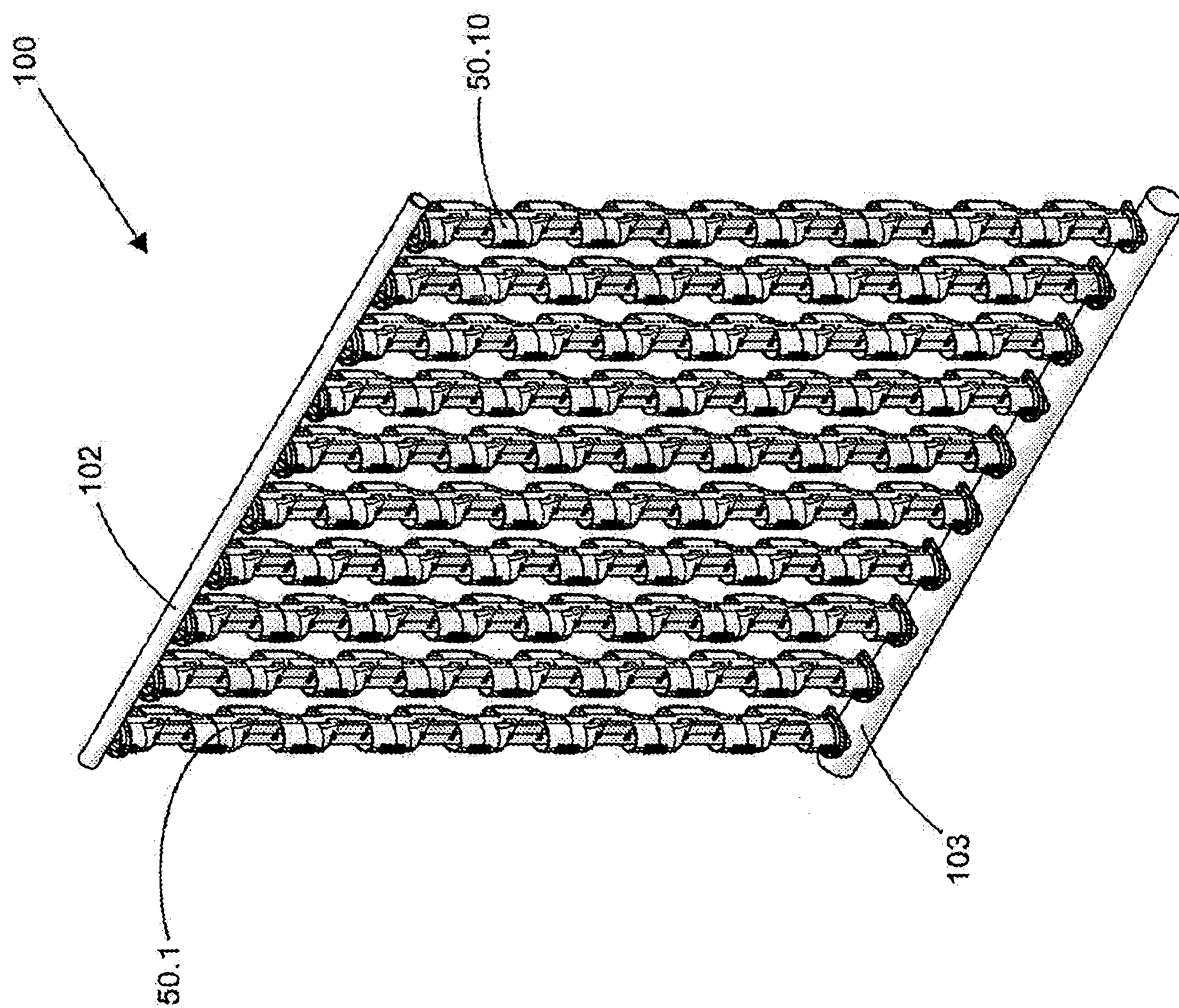

Fig 9

ABSTRACT

The invention relates to a planter (10) forming part of a hydroponic system. The planter (10) includes a longitudinal body (12) defining at least two longitudinally extending liquid channels (14.1, 14.2) and at least two plant holders (16, 18) defined in the body (12), the plant holders (16, 18) spaced on the outer circumference of the longitudinal body (12), each one of the at least two plant holders (16, 18) in fluid flow communication with one of the at least two longitudinally extending liquid channels (14.1, 14.2).

Fig. 3