

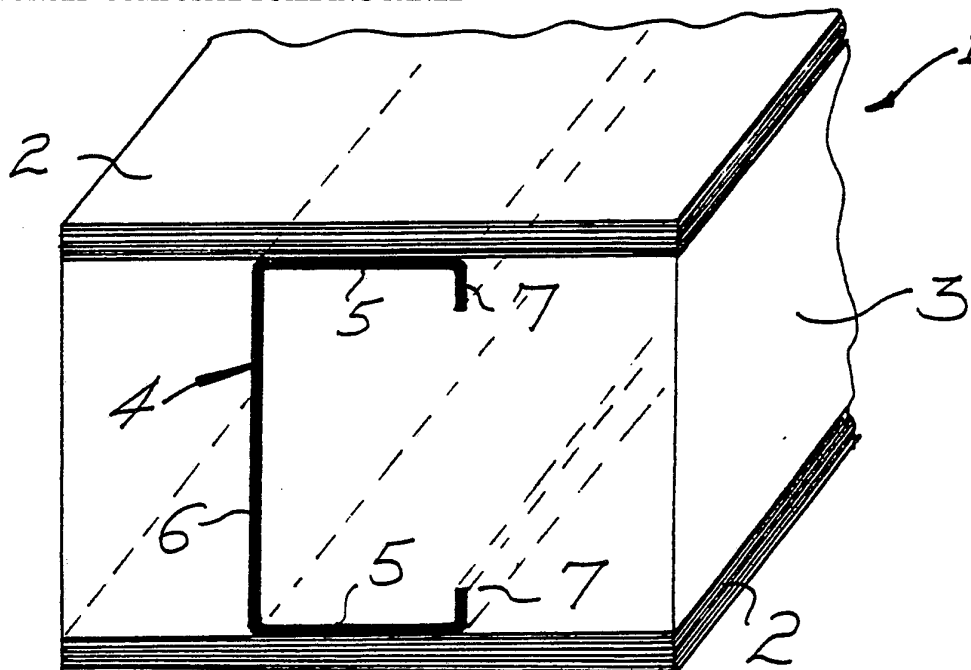

## INTERNATIONAL APPLICATION PUBLISHED UNDER THE PATENT COOPERATION TREATY (PCT)

<p>(51) International Patent Classification <sup>5</sup> : E04C 2/06, 2/36</p>	<p>A1</p>	<p>(11) International Publication Number: <b>WO 93/12303</b> (43) International Publication Date: 24 June 1993 (24.06.93)</p>
<p>(21) International Application Number: PCT/AU92/00664 (22) International Filing Date: 16 December 1992 (16.12.92) (30) Priority data: PL 0095 18 December 1991 (18.12.91) AU (71) Applicant (for all designated States except US): JAMES HARDIE &amp; COY. PTY. LIMITED [AU/AU]; 1 Grand Avenue, Camellia, NSW 2142 (AU). (72) Inventor; and (75) Inventor/Applicant (for US only) : SEACH, Barry, George [AU/AU]; 8 Philip Place, Carlingford, NSW 2118 (AU). (74) Agent: ALLEN, Leon, Keith; Shelston Waters, 55 Clarence Street, Sydney, NSW 2000 (AU).</p>		<p>(81) Designated States: AT, AU, BB, BG, BR, CA, CH, CS, DE, DK, ES, FI, GB, HU, JP, KP, KR, LK, LU, MG, MN, MW, NL, NO, NZ, PL, PT, RO, RU, SD, SE, UA, US, European patent (AT, BE, CH, DE, DK, ES, FR, GB, GR, IE, IT, LU, MC, NL, PT, SE), OAPI patent (BF, BJ, CF, CG, CI, CM, GA, GN, ML, MR, SN, TD, TG).  Published <i>With international search report.</i></p>

(54) Title: REINFORCED COMPOSITE BUILDING PANEL



(57) Abstract

The present invention relates to composite building panels (1) of the kind comprising two parallel opposed spaced apart facing sheets (2) having an intermediate core of cementitious material (3) adhered therebetween. Panels according to the invention include a reinforcing bridging member (4) that is disposed between the facing sheets and which is at least partially embedded within the cementitious core. This bridging member (4) has an ultimate shear strain to failure that is greater than that of the cementitious core. The reinforcing bridging member increases both the bending strength and impact strength of the panels, the cementitious material helping to prevent the bridging member from failing due to buckling. This allows the use of relatively light reinforcing sections. Furthermore, the reinforcements can be advantageously positioned along the edge of the panel to provide a means of jointing the panels.

*FOR THE PURPOSES OF INFORMATION ONLY*

Codes used to identify States party to the PCT on the front pages of pamphlets publishing international applications under the PCT.

AT	Austria	FR	France	MR	Mauritania
AU	Australia	GA	Gabon	MW	Malawi
BB	Barbados	GB	United Kingdom	NL	Netherlands
BE	Belgium	GN	Guinea	NO	Norway
BF	Burkina Faso	GR	Greece	NZ	New Zealand
BG	Bulgaria	HU	Hungary	PL	Poland
BJ	Benin	IE	Ireland	PT	Portugal
BR	Brazil	IT	Italy	RO	Romania
CA	Canada	JP	Japan	RU	Russian Federation
CF	Central African Republic	KP	Democratic People's Republic of Korea	SD	Sudan
CG	Congo	KR	Republic of Korea	SE	Sweden
CH	Switzerland	KZ	Kazakhstan	SK	Slovak Republic
CI	Côte d'Ivoire	LI	Liechtenstein	SN	Senegal
CM	Cameroon	LK	Sri Lanka	SU	Soviet Union
CS	Czechoslovakia	LU	Luxembourg	TD	Chad
CZ	Czech Republic	MC	Monaco	TG	Togo
DE	Germany	MG	Madagascar	UA	Ukraine
DK	Denmark	ML	Mali	US	United States of America
ES	Spain	MN	Mongolia	VN	Viet Nam
FI	Finland				

- 1 -

Title: "REINFORCED COMPOSITE BUILDING PANEL"

#### TECHNICAL FIELD

The present invention relates to an improved composite building panel for use in constructing walls, partitions and the like.

#### BACKGROUND ART

The invention has been developed primarily for improving the strength of lightweight panels incorporating lightweight core materials and will be described hereinafter with reference to this use.

However, it will be appreciated that the invention is not limited to this particular type of panel.

Composite building panels of the kind referred to above made by placing a lightweight core material between two flat, parallel facing sheets are widely used. Panels of this type are typically manufactured by filling the space between two adjacent fibre reinforced cement (FRC) sheets with a lightweight concrete core.

- 2 -

Such lightweight concrete cored panels are generally only suitable for the construction of non-load bearing fire rated walls and partitions as they do not have sufficient strength for load-bearing applications.

The bending strength of these lightweight concrete cored panels is primarily due to the strength of the facing sheets. The lightweight core bonds the two facing sheets together and resists shear between the facing sheets but does not contribute substantially to the bending strength of the panels as a whole.

Whilst it has been proposed to increase the bending strength of the panels by using thicker and stronger facing sheets and/or making the panels thicker by increasing the core thickness, both of these options are undesirable in that they add substantially to the cost and weight of the panels.

Another known option is to reinforce the individual facing sheets. Whilst this may serve to increase the relative bending strength of the facing sheets, it has been found that the most likely result is that the panels will then fail by core shear failure.

Physical testing of lightweight concrete cored panels of the kind described has shown that they fail in bending in two different ways depending on the relative strength of the core material and facings. When the core shear strength is adequate the panels fail in bending when facing sheets fail in tension. Conversely,

- 3 -

when the core shear strength is inadequate, the panels fail by core shear failure and/or delamination of the core from the facing sheets.

It is an object of the present invention to provide an improved composite building panel which will avoid or at least ameliorate the disadvantages of the prior art.

#### DISCLOSURE OF THE INVENTION

According to the invention there is provided a reinforced composite building panel comprising, two parallel opposed spaced apart facing sheets, an intermediate core of cementitious material adhered therebetween, and at least one reinforcing bridging member disposed intermediate said facing sheets and at least partially embedded within said core, said bridging member having an ultimate shear strain to failure that is greater than that of the cementitious core.

Desirably, the bridging member extends substantially the thickness of the core. In a preferred form the bridging member is connected to one or both of the opposing faces of the facing sheets with a suitable adhesive and/or suitable mechanical fasteners. Preferably, the facing sheets are made from fibre reinforced cement (FRC).

It is further preferred that the cementitious core comprise a low density material such as foamed concrete or a lightweight aggregate concrete incorporating, for example, expanded mineral beads or other suitable

- 4 -

materials.

Preferably, the bridging member includes flange means extending from an interconnecting web, the flanges serving to both assist connection of the bridging member to the facing sheets and simultaneously stiffen the facing sheets.

In preferred embodiments the bridging members are in the form of elongate sheet metal channel sections or Z-section studs. In another embodiment the web of the bridging member is profiled to form a tongue and groove profile, which when located at the edge of a panel can simultaneously serve as a means of jointing the panels.

Where the panels are required to be fire resistant it is preferred that the web of the bridging member is perforated to minimise thermal conduction through the thickness of the panel.

#### BRIEF DESCRIPTION OF THE DRAWINGS

Preferred embodiments of the invention will now be described with reference to the accompanying drawings in which:

Figure 1 is a schematic perspective view of a first embodiment composite building panel according to the invention.

Figure 2 is a schematic sectional view of a second variation of the building panel shown in Figure 1.

Figure 3 is a schematic sectional view of a second embodiment panel according to the invention.

- 5 -

Figure 4 is a schematic perspective view of a bridging member particularly suited for use in a fire resistant panel according to the invention.

Figure 5 is another suitable bridging member for use in a panel according to the invention.

Figures 6 and 7 are schematic perspective views of a third embodiment of the panel according to the invention where the bridging members simultaneously form tongue and groove jointing edges.

Figures 8 and 9 show another variation on the tongue and groove arrangement shown in Figures 6 and 7.

Figure 10 is a schematic perspective view of a fourth embodiment wherein the bridging member forms a protective edge to the panel.

#### BEST MODE FOR CARRYING OUT THE INVENTION

Referring first to Figure 1, the building panel 1 comprises two parallel opposed spaced apart facing sheets 2 preferably made from fibre reinforced concrete (FRC) and an intermediate core of compression resistant cementitious material 3 adhered between the sheets 2. The core material comprises in the preferred embodiments either a lightweight foamed concrete or a lightweight aggregate concrete. However, other cementitious materials such as gypsum or portland cement can also be used.

Disposed within the core 3 is at least one substantially channel shaped sheet metal bridging member

- 6 -

or reinforcing member 4 comprising connecting flanges 5 and an interconnecting web 6. Stiffening flanges 7 are also provided in the first embodiment which extend contiguously from connecting flanges 5. The bridging member 4 connects to at least one of the opposing faces of the facing sheets 2 by means of adhesive applied to the connecting flanges 5.

Alternate embodiments of the invention will now be described and where appropriate like reference numerals used to denote corresponding features.

Referring next to Figure 2, there is shown a second embodiment of the invention where the bridging member is again in the form of a channel as shown in Figure 1 but incorporating wider connecting flanges 5. These wider flanges serve to increase the proportion of the reinforcement in contact with the FRC facing sheets to further stiffen the facing sheets 2.

Figure 3 shows an embodiment of the panel again utilising a channel shaped bridging member, this version omitting the stiffening flanges 7 shown in Figures 1 and 2.

Figure 4 illustrates an alternate bridging member or reinforcing member 4 suitable for use in a fire resistant panel according to the invention. The panel includes a plurality of perforations or cut-outs 8 in the interconnecting web 9.

Figure 5 shows a further alternate channel shaped



- 7 -

bridging member 4 including corrugated stiffening flanges 7 to improve the connection between the bridging member and the lightweight concrete core.

Figures 6 to 10 illustrate various embodiments wherein the reinforcing bridging members are positioned at the edge of the panel to strengthen this part of the panel and, in Figures 6 to 9, simultaneously provide a tongue and groove arrangement for jointing the panels.

Figures 1, 2 and 3 show the bridging member 4 fully within the core 3 between the facing sheets 2. The bridging member 4 may also be arranged so that while its flanges are embedded within the core 3, its web 6 is exposed to form one edge of the panel 1 as shown in Figures 6 to 10. Web 6 when thus exposed to form one edge of the panel 1 may usefully be contoured into a non-flat profile such as a tongue or groove profile that can be used for jointing of panels. Two such arrangements are shown in Figures 6 to 9.

To form the panels herein described, the facing sheets are spaced apart and one or more bridging members or reinforcing channels are arranged therebetween. It may be advantageous to attach the reinforcing channels to one or both of the sheets first by means of adhesive or mechanical fasteners. However, this is not essential as the cementitious core will adhere to the facing sheets and bridging members to assemble the panel. Lightweight concrete is then poured into the cavities

- 8 -

between the facing sheets. The concrete is then allowed to cure, either naturally or by accelerated means, until the panel has sufficient strength to be removed from its mould without damage.

Lightweight concrete for use in manufacture of building panels is typically made by adding either pre-made air/water chemical foam or expanded lightweight aggregate beads to a water borne cement slurry. The density of lightweight concrete typically ranges from  $200\text{kg/m}^3$  to  $1800\text{kg/m}^3$ . Normal weight concrete has a density typically in the range  $1800\text{kg/m}^3$  to  $2600\text{kg/m}^3$ .

Composite building panels are also commonly made by fastening sheets, such as FRC sheets, as facings to both sides of a metal frame comprising sheet metal channel studs, top and bottom plates and noggins. Panels of this type may also be filled with low density insulation for increased thermal resistance. However, physical testing has shown that metal framed panels generally fail in bending when the metal channel studs fail by buckling.

#### EXAMPLES

In order to determine the comparative strengths of panels made according to the invention and reinforced panels having no core material, a series of tests were conducted.

Two sets of four composite building panels

- 9 -

specimens were made from the same batch of metal stud bridging or reinforcing members and facing sheets. They were all 1200mm long x 600mm wide x 75mm thick, with 4.5mm thick "Versilux" panels which are FRC facing sheets manufactured by James Hardie & Coy Pty Ltd.

In each panel, four galvanised steel channels 64mm deep x 35mm wide x 0.55mm steel thickness were aligned in the long direction of the panel, equally spaced and adhesive bonded to the FRC facing sheets with for example, a solvent based neoprene such as that manufactured by the H.B. Fuller Company sold under the trade mark "Fulaprene 303". One set of four specimens was filled with lightweight concrete of  $600\text{kg/m}^3$  nominal density.

Both sets of building panels were tested in bending as simply supported beams using an A-grade universal testing machine. A comparison of the observed bending test results of the composite building panel specimens is given in table 1 below. The ultimate load is the maximum load sustained by each panel. The ultimate deflection is the deflection under the load of each panel at the ultimate load state. The energy of fracture is the integral of load with respect to deflection, from the no load state to the ultimate load state.

- 10 -

<u>Panel Core</u> <u>Detail</u>	<u>Failure</u> <u>Mode</u>	<u>Ultimate</u> <u>Strength</u> kN	<u>Ultimate</u> <u>Deflection</u> mm	<u>Energy of</u> <u>Fracture</u> Nm
No core	Steel Buckling	14.1	18.3	148
No core	Steel Buckling	13.3	14.1	100
No core	Steel Buckling	14.0	16.8	134
No core	Steel Buckling	14.3	17.7	144
Averages		13.9	16.7	132
Foam Concrete	Steel Yield	17.3	38.4	422
Foam Concrete	Steel Yield	18.8	84.4	1381
Foam Concrete	Steel Yield	18.7	79.1	1286
Foam Concrete	Steel Yield	18.4	76.2	1204
Averages		18.3	69.5	1073

Table 1. Composite Building Panel Bending Test Results

The test results given in table 1, demonstrate the ultimate strength, deflection and energy of fracture of each foamed concrete cored panel is greater than that of each of the non-cored panels. The presence of the lightweight concrete core prevented buckling of the steel channel stud reinforcement enabling it to hold a higher load before failure in yielding.

The prevention of buckling failure by the lightweight concrete core allows use of reinforcement channels with wider flanges than could otherwise be used, as shown in figure 2. Such wider flanges serve to increase the proportion of metal within each reinforcement channel in contact with the FRC facing sheet and therefore the efficiency of achieving a particular strength and stiffness.

In addition, the prevention of buckling failure by

- 11 -

the lightweight concrete core allows use of reinforcement channels without stiffening flanges as shown in figure 3. Such reinforcement channel without stiffening flanges are less expensive and use their strength more efficiently than otherwise.

It has also been shown that the prevention of buckling failure by the lightweight concrete core allows use of reinforcement channels with webs containing holes and cut-outs as shown in figure 4. Such holes and cut-outs reduce thermal conduction from one face of the panel to the other in a fire situation.

Furthermore, the prevention of buckling failure by the lightweight concrete core also allows use of reinforcement channels with undulating stiffening flanges as shown in figure 5. Such undulating flanges increase the connection between the reinforcement channel and the lightweight concrete core increasing the strength of the panel.

It is also noted that the use of metal reinforcement channels which are bonded to the facing sheets in a composite building panel filled with a lightweight concrete core serves to restrain the core during fire exposure preventing dislodgment. This increases the time for which the panel is able to resist fire.

Additionally, the use of metal reinforcement channels allows manufacture of panels with joints in

- 12 -

their facing sheets, without large losses in strength and stiffness.

In summary, the physical testing has therefore shown, that when cured, the panels according to the invention have higher bending strength than either unreinforced composite panels or hollow cored metal framed panels.

When the panels according to the invention are subjected to bending, the lightweight concrete core provides support to the metal channel studs. This support prevents buckling failure of the metal channel studs which are able to carry a higher load than if they had buckled. The lightweight concrete core also bonds the facing sheets together so that they also make a significant contribution to the bending strength of the panels.

Conversely, the bending strength of metal framed panels faced with FRC sheets is primarily due to the strength of the metal frame. The impact strength of these panels is low because the FRC facing sheets are only supported over the framing. Between the framing, the support given to the FRC facing sheets by the foamed plastic insulation material, if present, is minimal.

In alternate embodiments not illustrated, the bridging member may be made from other materials, the only requirement being that the bridging member have a higher shear strain to failure than the core material.

- 13 -

Furthermore, whilst the embodiments described use substantially 'C'- shaped channel sections, other section shapes can also be used such as 'Z' section, "I" section etc.

Similarly, the use of other facing sheet and core materials has been contemplated and are deemed to fall within the scope of the invention. Similarly, although this invention has been described with reference to flat wall panels, it is also applicable to corner panels and other building elements such as floor, ceiling and roof panels.

Although the invention has been described with reference to the specific examples, it will be appreciated by those skilled in the art that the invention may be embodied in many other forms.

- 14 -

## CLAIMS:-

1. A reinforced composite building panel comprising, two parallel opposed spaced apart facing sheets, an intermediate core of cementitious material adhered therebetween, and at least one reinforcing bridging member disposed intermediate said facing sheets and at least partially embedded within said core, said bridging member having an ultimate shear strain to failure that is greater than that of the cementitious core.
2. A reinforced composite building panel according to claim 1 wherein the bridging member extends substantially the thickness of the core.
3. A reinforced composite building panel according to claim 2 wherein the bridging member is connected to at least one of the opposing faces of the facing sheets.
4. A reinforced composite building panel according to claim 3 wherein the bridging member is connected to said facing sheet by use of a suitable adhesive and/or mechanical fastener.
5. A reinforced composite building panel according to any one of the preceding claims wherein the cementitious core comprises a light weight concrete having a density of between  $200\text{kg/m}^3$  to  $1800\text{kg/m}^3$ .
6. A reinforced composite building panel according to claim 5 wherein the cementitious core comprises a foamed concrete or light weight aggregate concrete.
7. A reinforced composite building panel according



- 15 -

to any one of the preceding claims wherein the bridging member includes at least one flange extending from a web, the flange extending substantially parallel to the facing sheets.

8. A reinforced composite building panel according to any one of the preceding claims wherein the bridging member is in the form of an elongate sheet metal channel or z-section stud.

9. A reinforced composite building panel according to any one of the preceding claims wherein the web of the bridging member is perforated to minimise thermal conduction through the thickness of the panel.

10. A reinforced composite building panel according to any one of the preceding claims wherein the bridging member is located along an edge of said panel, the web of the bridging member being profiled to form a jointing tongue or groove.

11. A reinforced composite building panel substantially as herein described with reference to the accompanying drawings.

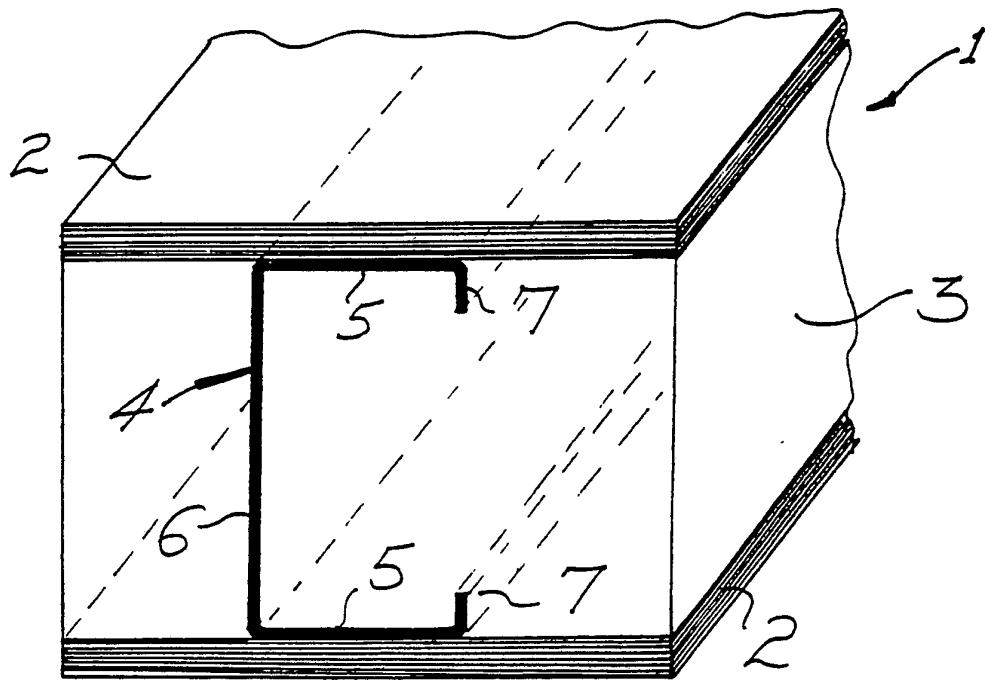

FIG. 1

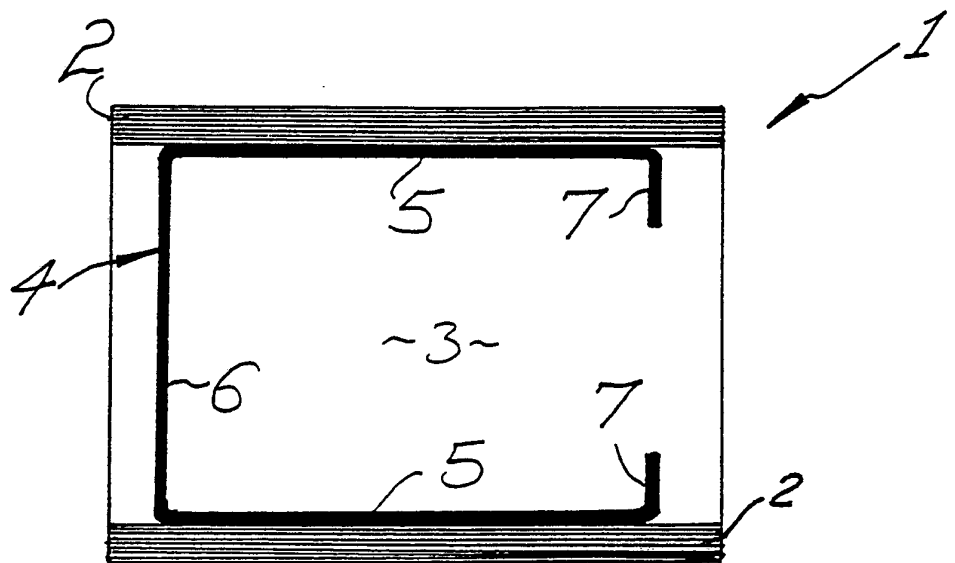

FIG. 2

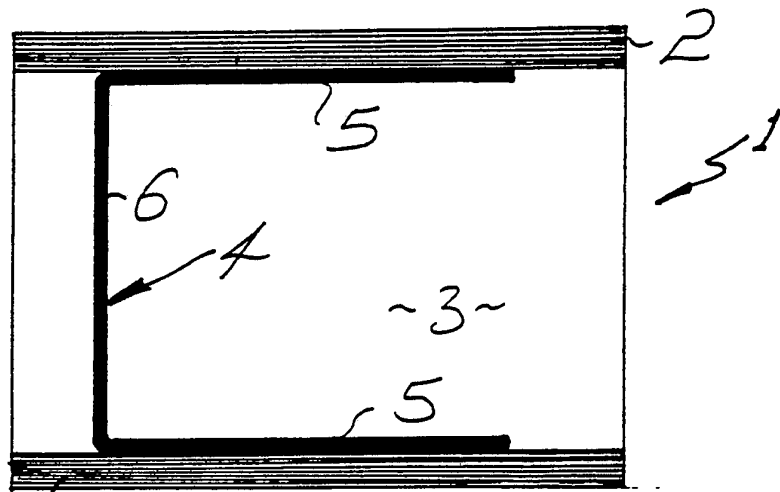

FIG. 3

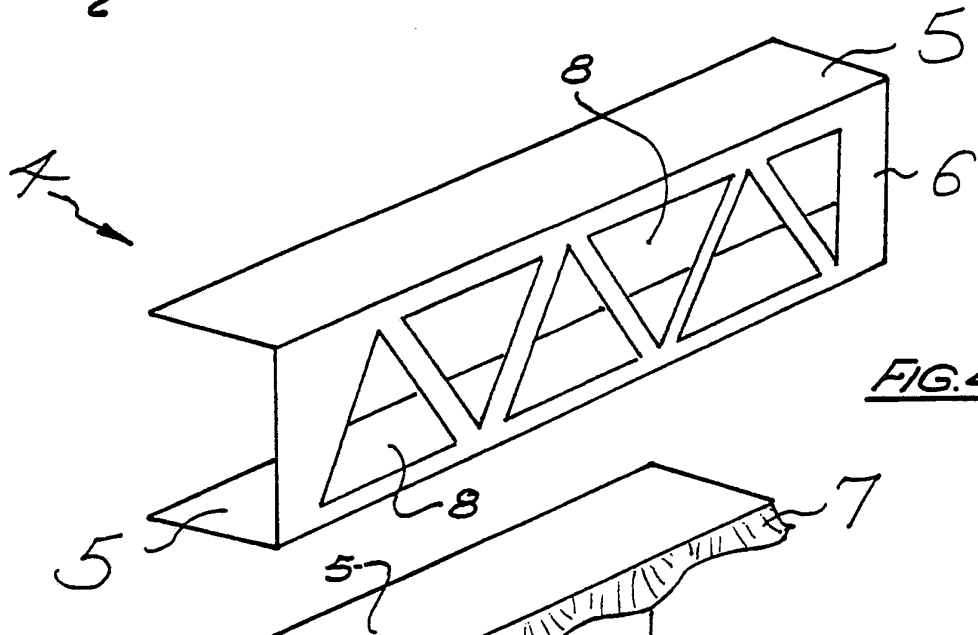

FIG. 4

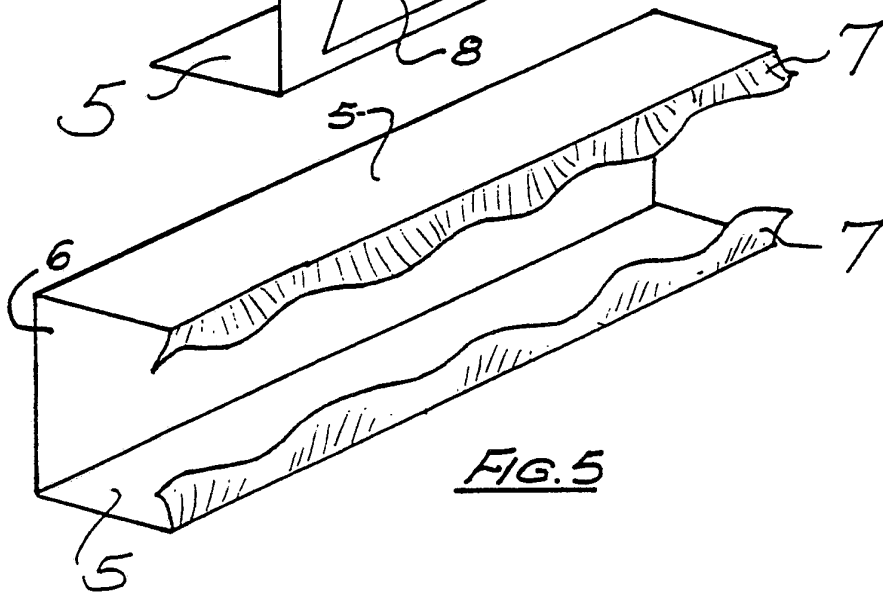
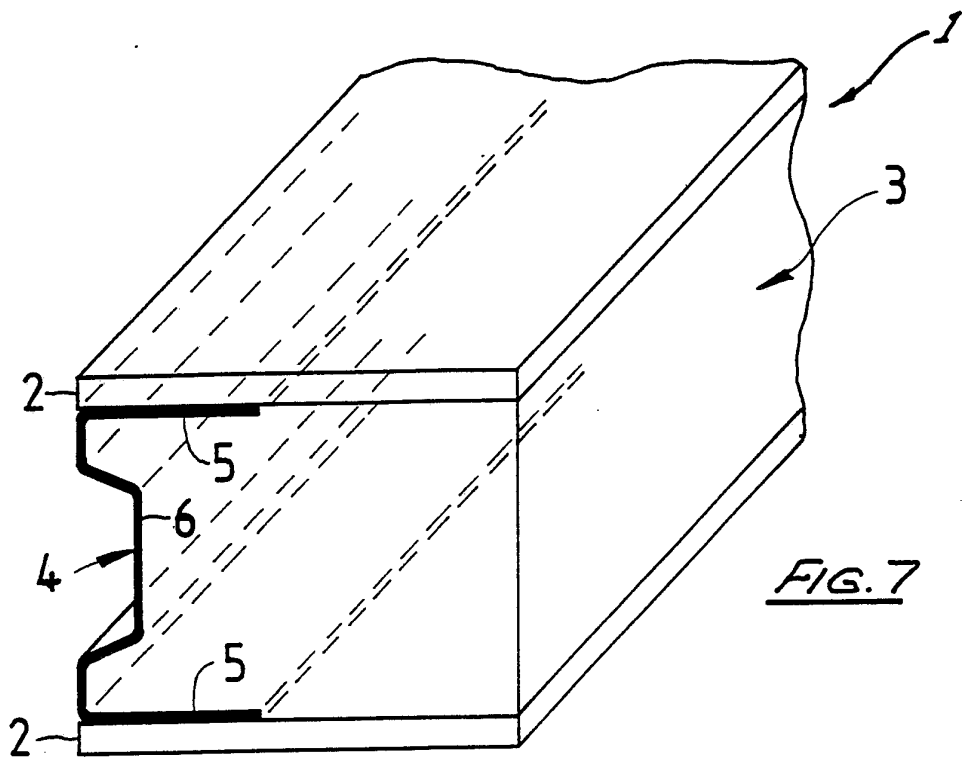
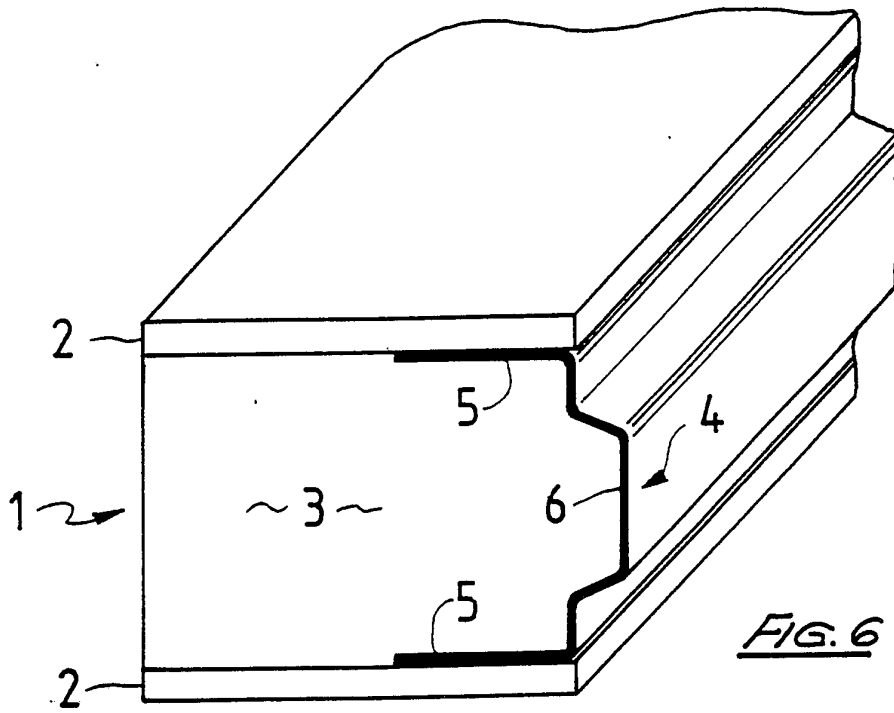
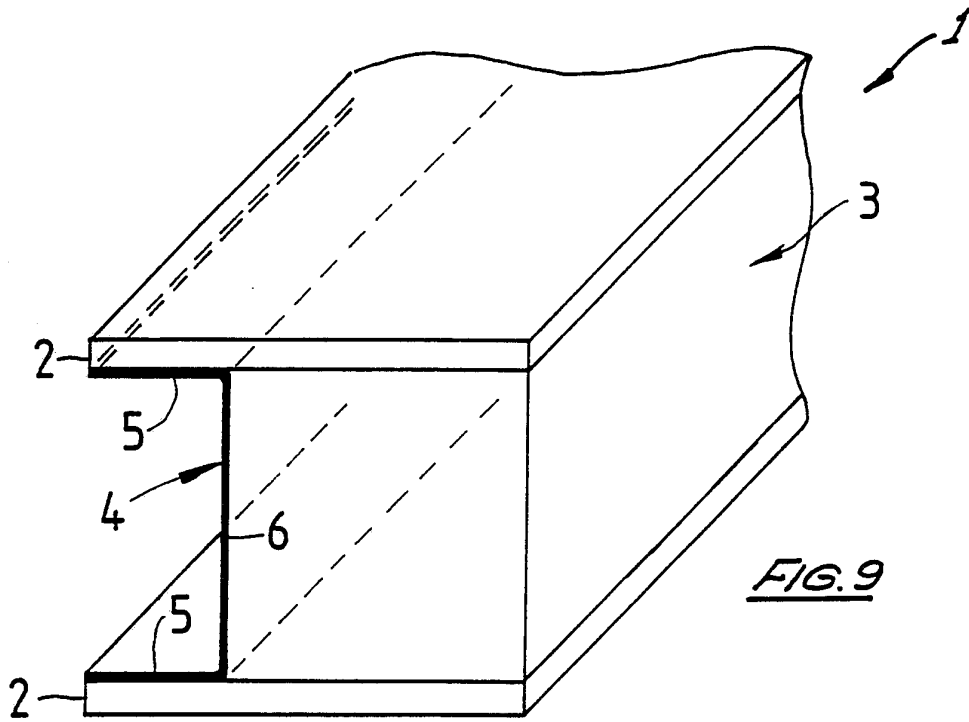
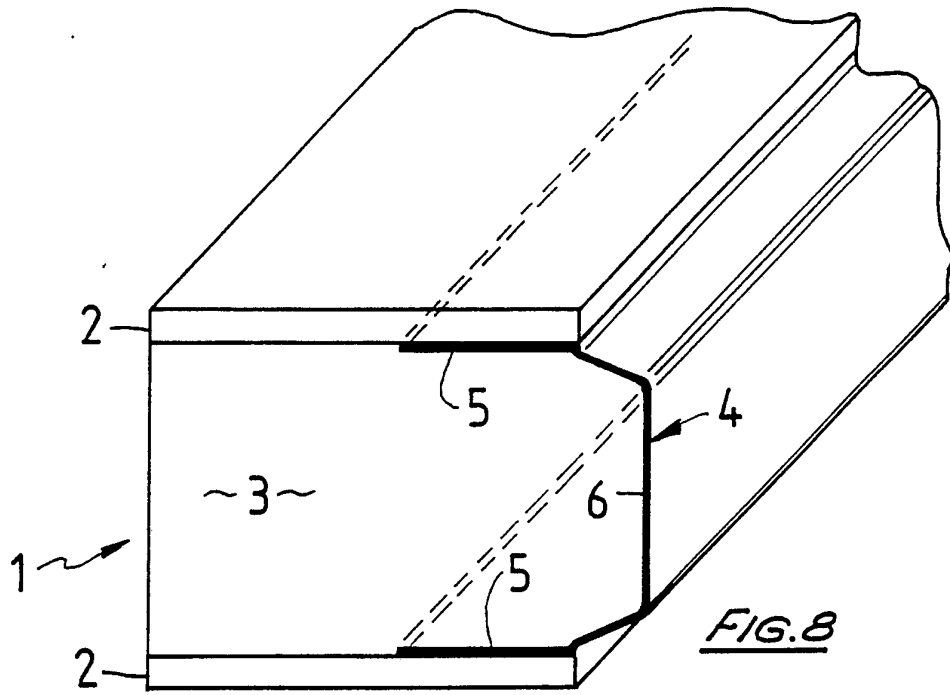

FIG. 5





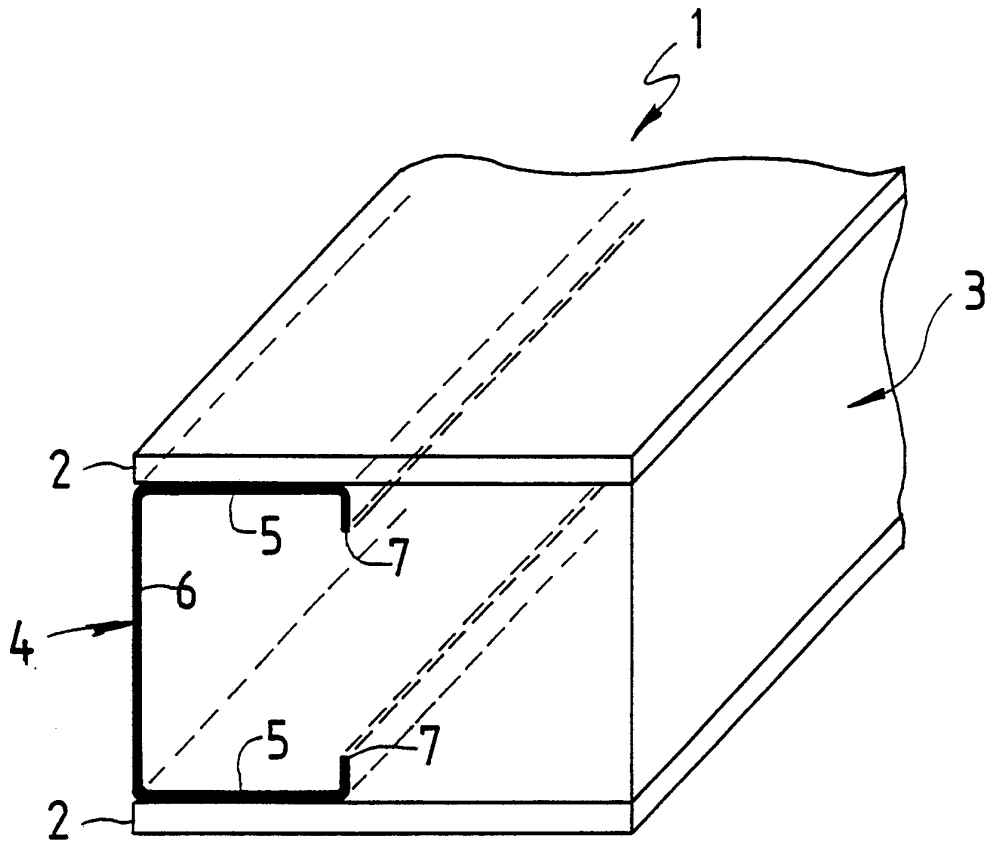



FIG. 10

<b>A. CLASSIFICATION OF SUBJECT MATTER</b> Int. Cl. <sup>5</sup> E04C 2/06, 2/36  According to International Patent Classification (IPC) or to both national classification and IPC		
<b>B. FIELDS SEARCHED</b>  Minimum documentation searched (classification system followed by classification symbols): IPC E04C 2/06, 2/36  Documentation searched other than minimum documentation to the extent that such documents are included in the fields searched AU : IPC as above  Electronic data base consulted during the international search (name of data base, and where practicable, search terms used) JAPIO DERWENT		
<b>C. DOCUMENTS CONSIDERED TO BE RELEVANT</b>		
Category*	Citation of document, with indication, where appropriate, of the relevant passages	Relevant to Claim No.
X	GB,A, 2077802 (KOOR METALS LTD) 23 December 1981 (23.12.81) Figure 1	1-3
X	GB,B, 1600653 (SA RTORIO) 21 October 1981 (21.10.81) Figures 2,6	1-3
X	GB,B, 1360430 (BLUM) 17 July 1974 (17.07.74) Figure 1	1-3
X	DE,A, 2422091 (PACENTI) 21 November 1974 (21.11.74) Figure 6	1-3,8,9
<input checked="" type="checkbox"/> Further documents are listed in the continuation of Box C. <input checked="" type="checkbox"/> See patent family annex.		
* Special categories of cited documents :		
"A"	document defining the general state of the art which is not considered to be of particular relevance	"T" later document published after the international filing date or priority date and not in conflict with the application but cited to understand the principle or theory underlying the invention
"E"	earlier document but published on or after the international filing date	"X" document of particular relevance; the claimed invention cannot be considered novel or cannot be considered to involve an inventive step when the document is taken alone
"L"	document which may throw doubts on priority claim(s) or which is cited to establish the publication date of another citation or other special reason (as specified)	"Y" document of particular relevance; the claimed invention cannot be considered to involve an inventive step when the document is combined with one or more other such documents, such combination being obvious to a person skilled in the art
"O"	document referring to an oral disclosure, use, exhibition or other means	"&" document member of the same patent family
"P"	document published prior to the international filing date but later than the priority date claimed	
Date of the actual completion of the international search 26 March 1993 (26.03.93)		Date of mailing of the international search report 5 APR 1993 (5.4.93)
Name and mailing address of the ISA/AU AUSTRALIAN PATENT OFFICE PO BOX 200 WODEN ACT 2606 AUSTRALIA  Facsimile No. 06 2853929		Authorized officer   D. LUM  Telephone No. (06) 2832544

C(Continuation). DOCUMENTS CONSIDERED TO BE RELEVANT		
Category *	Citation of document, with indication, where appropriate of the relevant passages	Relevant to Claim No.
A	US,A, 3905171 (CARGILL et al) 16 September 1975 (16.09.75) Figure 1	
A	US,A, 2839812 (BERLINER) 24 June 1958 (24.06.58) Figure 6	
A	US,A, 2667060 (CAMPBELL) 26 January 1954 (26.01.54) Figure 6	



## INTERNATIONAL SEARCH REPORT

Information on patent family members

International application No.

PCT/AU92/00664

This Annex lists the known "A" publication level patent family members relating to the patent documents cited in the above-mentioned international search report. The Australian Patent Office is in no way liable for these particulars which are merely given for the purpose of information.

Patent Document Cited in Search Report		Patent Family Member					
GB	2077802	CH	650829	DE	3114617	HK	306/87
		IL	59817	KE	3681	US	4433522
		ZA	8102405				
GB	1600653	CH	628946	DE	2803629	ES	466984
		FR	2378910	IT	1061821	US	4261150
GB	1360430	CH	536407	FR	2111811	LU	64130
		NL	7114325	BE	774295		
AU	29421/71			NIL			
DE	2422091	AU	68673/74	CA	1004021	DE	2462243
		DE	2462244	DE	2462245	US	3872636
		ZA	7402903				
END OF ANNEX							