(12) PATENT ABRIDGMENT (11) Document No. AU-B-29986/89
(19) AUSTRALIAN PATENT OFFICE (10) Acceptance No. 618783

- (54) Title
LOW VIBRATION RESONANT SCANNING UNIT FOR MINIATURE OPTICAL DISPLAY APPARATUS
- International Patent Classification(s)
(51)⁴ **H04N 003/10 G09F 009/37**
- (21) Application No. : **29986/89** (22) Application Date : **16.02.89**
- (30) Priority Data
- (31) Number (32) Date (33) Country
200645 31.05.88 US UNITED STATES OF AMERICA
- (43) Publication Date : **07.12.89**
- (44) Publication Date of Accepted Application : **09.01.92**
- (71) Applicant(s)
REFLECTION TECHNOLOGY, INC.
- (72) Inventor(s)
BENJAMIN A. WELLS
- (74) Attorney or Agent
DAVIES COLLISON CAVE , 1 Little Collins Street, MELBOURNE VIC 3000
- (56) Prior Art Documents
AU 18940/88 H04N 3/08 3/12 3/14 5/66 9/12 9/14 9/30 13/04
US 4732440
US 4632501
- (57) Claim

1. A resonant electromechanical scanning unit comprising;
 - a base;
 - a mirror;
 - first spring means connecting said mirror to said base so as to allow said mirror to oscillate relative to said base, said mirror and said first spring means forming a first spring/mass system having a first mechanical resonant oscillation frequency and transferring a first reaction force to said base;
 - a counterbalance mass;
 - second spring means connecting said counterbalance mass to said base so as to allow said counterbalance mass to oscillate relative to said base, said counterbalance mass and said second spring means forming a second spring/mass system having a second mechanical resonant oscillation frequency substantially equal to said first mechanical resonant oscillation frequency and transferring a second reaction

(11) AU-B-29986/89
(10) 618783

-2-

force to said base; and

driving motor means for imparting motion to at least one of said mirror and said counterbalance mass, said first spring means and said second spring means being connected to said base so that said first reaction force and said second reaction force substantially cancel at said base.

COMMONWEALTH OF AUSTRALIA

PATENTS ACT 1952

COMPLETE SPECIFICATION

618783

NAME & ADDRESS
OF APPLICANT:

Reflection Technology, Inc.
240 Bear Hill Road
Waltham Massachusetts 02154
United States of America

NAME(S) OF INVENTOR(S):

Benjamin A. WELLS

ADDRESS FOR SERVICE:

DAVIES & COLLISON
Patent Attorneys
1 Little Collins Street, Melbourne, 3000.

COMPLETE SPECIFICATION FOR THE INVENTION ENTITLED:

Low vibration resonant scanning unit for miniature optical display apparatus

The following statement is a full description of this invention, including the best method of performing it known to me/us:-

FIELD OF THE INVENTION

This invention relates to display devices which generate a raster scan image by using a line of light-emitting devices displayed by means of an oscillating mirror. More particularly, the invention relates to means for reducing vibration in such devices caused by the rapid oscillation of the mirror.

BACKGROUND OF THE INVENTION

There are many different types of display devices which can visually display information such as figures, numbers and video information. These devices include the ubiquitous cathode ray tube in which a raster is created by repetitively sweeping an electron beam in a rectangular pattern. The image is created by selectively modulating the beam to generate light and dark spots on the raster.

Another display device is an electromechanical scanning system in which a line of light-emitting devices is modulated with the information to be

displayed. The illuminated line is converted into a raster by means of an oscillating mirror thereby generating a virtual raster image. These latter devices have the advantage that a full "page" display can be created from a much smaller number of light-emitting devices than is necessary to generate a normal full page real image.

In operation, an enlarged, virtual image of the illuminated devices is reflected from a mirror as the mirror is being physically pivoted about a fixed axis by means of an electromagnetic motor. Although it is possible to directly drive the mirror to produce oscillations, in order to reduce the power necessary to drive the mirror, it is possible to use a resonant electromechanical oscillator to move the mirror. In such an oscillator, the mirror is mounted on a spring attached to a frame so that the mass of the mirror and the spring create a mechanical resonator. An electromagnetic motor oscillates the mirror mass at the resonant frequency of the spring/mirror system. In this manner, only a small amount of power is needed to produce a relatively large oscillation. Such a conventional resonant oscillator is shown in U.S. Patent 4,632,501 in which the mirror is attached to the base by a thin sheet of spring material.

A problem with the conventional mirror/spring oscillator system is that the rapid angular oscillation of the mirror requires a large spring force to accelerate and decelerate the mirror. The spring force is also applied to the base of the device and constitutes a "reaction force". When the base is rigidly secured to a relatively massive object, this force is not a serious concern. However, when it is impossible or undesirable to attach the display device to a massive object, as is the case for hand-held, eyeglass-mounted or "heads-up" displays, the force causes vibrations which are, at best, annoying and, in some cases, may cause the resulting image to be blurred or even unintelligible. In addition, the vibration can disrupt the function of an accompanying instrument, such as a microscope, that is sensitive to vibration. Further, even if the vibration is acceptable, the power required to oscillate the mirror increases when the vibration is transmitted to an external structure. This extra power means a larger motor is required to insure that the motor can drive the display with sufficient amplitude, in turn, resulting in increased battery drain for portable displays.

This problem is even more serious if the system design requires that the mirror pivot about a point

near the end of the mirror as opposed to near the center of the mirror. Such a design is desirable in a hand-held display application because it permits use of smaller lenses and results in a more compact display.

Accordingly, it is an object of the present invention to provide a resonant scanning unit for an optical display device in which the net reaction force transferred to the mounting base is reduced.

It is a further object of the present invention to provide a resonant scanning unit which reduces vibration in a resonant-scanning optical display device.

It is yet another object of the present invention to provide a resonant scanning unit which allows the electromagnetic motor which drives the mirror to operate in an efficient manner.

It is yet another object of the present invention to provide a resonant scanner construction which uses a counter-balanced mass construction to reduce the net reaction force transmitted to the mounting base.

It is still a further object of the present invention to provide a resonant scanning unit in which the pivot point about which the mirror oscillates is located at a distance from the mirror center.

SUMMARY OF THE INVENTION

In accordance with the present invention there is provided a resonant electromechanical scanning unit comprising;

a base;

5 a mirror;

first spring means connecting said mirror to said base so as to allow said mirror to oscillate relative to said base, said mirror and said first spring means forming a first spring/mass system having a first mechanical resonant oscillation frequency and transferring a first reaction force to said base;

10 a counterbalance mass;

second spring means connecting said counterbalance mass to said base so as to allow said counterbalance mass to oscillate relative to said base, said counterbalance mass and said second spring means forming a second spring/mass system having a second mechanical resonant oscillation frequency substantially equal to said first mechanical resonant oscillation frequency and transferring a second reaction force to said base; and

driving motor means for imparting motion to at least one of said mirror and said counterbalance mass, said first spring means and said second spring means being connected to said base so that said first reaction force and said second reaction force substantially cancel at said base.

20 The present invention also provides a resonant electromechanical scanning unit comprising;

a base;

a mirror;

25 a first spring means connecting said mirror to said base so as to allow said mirror to oscillate about a first pivot point relative to said base, said mirror and said first spring means forming a first spring/mass system having a first mechanical resonant oscillation frequency and transferring a first reaction force to said base;

a counterbalance mass;

30 a second spring means connecting said counterbalance mass to said base so as to allow said counterbalance mass to oscillate about a second pivot point relative to said base, said counterbalance mass and said second spring means forming a



second spring/mass system having a second mechanical resonant oscillation frequency substantially equal to said first mechanical resonant oscillation frequency and transferring a second reaction force to said base; and

5 a voice coil driving motor mounted on said mirror and said counterbalance mass for simultaneously imparting opposite motions to said mirror and to said counterbalance mass, said first pivot point being located on said base relative to said second pivot point so that said first reaction force and said second reaction force substantially cancel at said base.

The present invention further provides a miniature optical display device for
10 generating a raster image to display selected information, said display device comprising:

a linear array of light-emitting devices;

a mirror;

15 an optical system located between said linear array and said mirror, said optical system projecting a virtual image of said linear array via said mirror;
a base;

first spring means connecting said mirror to said base so as to allow said mirror to oscillate relative to said base, said mirror and said first spring means forming a first spring/mass system having a first mechanical resonant oscillation
20 frequency and imparting a first reaction force to said base;

a counterbalance mass;

second spring means connecting said counterbalance mass to said base so as to allow said counterbalance mass to oscillate relative to said base, said counterbalance mass and said second spring means forming a second spring/mass
25 system having a second mechanical resonant oscillation frequency substantially equal to said first mechanical resonant oscillation frequency and imparting a second reaction force to said base; and

driving motor means for imparting opposite motions to said mirror and to said counterbalance mass whereby said virtual image of said linear array is swept
30 by the motion of said mirror to produce a raster display, said first and second reaction forces substantially cancelling at said base.

The present invention also provides a miniature optical display device for



generating a raster image to display selected information, said display comprising:

a linear array of light-emitting devices;

a mirror;

an optical system located between said linear array and said mirror, said

5 optical system projecting a virtual image of said linear array via said mirror;

a base;

a first and a second flexure springs connecting said mirror to said base;

a counterbalance mass;

a third flexure spring connecting said counterbalance mass to said base so

10 that said counterbalance mass is adjacent said mirror;

an electrically conductive rectangular coil having an inner dimension and an outer dimension, said coil being mounted on said mirror;

a permanent magnet structure mounted on said counterbalance mass having a first, a second and a third finger, said first and third fingers being configured to
15 pass on either side of said coil when said mirror and said counterbalance mass move relative to each other, said second finger configured so as to fit within said inner dimension of said coil; and

driving circuit means for providing a periodic current to said coils so as to cause said mirror and said counterbalance mass to angularly rotate in opposite
20 directions back and forth in arc segments about fixed pivot points at said base so that the reaction force of said mirror at said base is substantially cancelled by the reaction force of said counterbalance mass at said base.

The present invention also provides in a miniature display apparatus which generates a raster image from a linear array of light-emitting devices, said display
25 device having a base, a mirror, a first spring connecting said mirror to said base at a first point and a driving mechanism for oscillating said mirror relative to said base, the reaction force generated by the motion of said mirror being transmitted through said spring to said base, a method for reducing the vibration of said base due to said reaction force, said method comprising the steps of:

- 30 A. mounting a counterbalance mass on said base by means of a second spring attached to said base at a second point, the mechanical resonant frequency of said mirror/first spring system being substantially equal to the mechanical



resonant frequency of said counterbalance mass/second spring system;

- B. providing a driving mechanism to oscillate said counterbalance mass, the reaction force produced by the oscillation of said counterbalance mass being conducted through said second spring to said base, and
- 5 C. positioning said first spring attachment point relative to said second spring attachment point so that the reaction force of said mirror is substantially cancelled by the reaction force of said counterbalance mass.

In one preferred embodiment, the mirror is mounted to the base of the display device by crossed flexure springs. A counterbalance mass is also
10 connected to the base of the video display device by a spring. The stiffness of both the mirror flexures and the counterbalance mass spring are selected so that the mirror and counterbalance mass have substantially the same resonant frequency.

In this embodiment, a voice-coil electromagnetic motor is used to drive the mirror and the counterbalance mass. The motor comprises a permanent magnet portion and associated magnetic return path mounted on one arm of the tuning fork configuration and a coil mounted on the other arm. When a properly controlled current is applied to the coil, the permanent magnet is alternately attracted and repulsed from the coil. In this fashion, a driving force is applied to both the mirror and the counterbalance mass causing each to oscillate at the frequency of the driving force.

The spring forces which accelerate and deaccelerate the mirror and counterbalance mass are also applied by the flexure springs to the base, and constitute "reaction forces". The geometry of the counterbalance mass and the counterbalance mass pivot point location are both selected so that the reaction force applied to the base by the counterbalance mass substantially cancels the reaction force applied to the base by the mirror.

In addition, the geometry of the electromagnetic motor is selected so that the drive forces applied to the mirror and counterbalance mass are substantially equal to the air resistance forces acting on the mirror and counterbalance mass, with the result that little or no net force is applied to the base due to drive forces.

BRIEF DESCRIPTION OF THE DRAWING

Figure 1 is a schematic view of a typical prior art resonant electromechanical scanner.

Figure 2 is a partial cross-sectional view of a resonant scanner constructed in accordance with the present invention.

Figure 3A is a schematic diagram of a miniature display using a scanning mirror which is pivoted near the mirror center.

Figure 3B is a schematic diagram of a miniature display using a scanning mirror which is pivoted near the mirror end.

Figure 4 is a perspective view of the resonant scanner shown in Figure 2.

Figure 5 is a perspective view of a preferred embodiment of a resonant scanner utilizing a drive motor with improved efficiency.

Figure 6 is a plan view of the preferred drive motor construction showing the mirror assembly overlaid by the counterbalance mass. Spring 42 which connects the mirror assembly to the base has been omitted for clarity.

Figure 7 is a cross-sectional view of the preferred drive motor embodiment taken along the line 7-7 shown in Figure 6.

Figure 8 is another cross-sectional view of the preferred drive motor embodiment taken along the line 8-8 shown in Figure 6.

Figure 9 is a longitudinal cross section of another embodiment using a sensor flag to sense position of the mirror 30.

Figure 10 is a partial exploded view of a portion of the embodiment shown in Figure 9 showing the voice coil with sensor flag, the counterbalance mass and the sensor assembly.

Figure 11 is an electrical schematic diagram of an illustrative drive circuit.

Figure 12 is a perspective view of a miniature optical display device utilizing an illustrative embodiment of the inventive scanner unit.

DETAILED DESCRIPTION OF PREFERRED EMBODIMENTS

Figure 1 is a schematic diagram of a typical prior art resonant electromechanical scanner of the type shown in U.S. patent 4,632,501. As this device is explained in detail in the latter patent, it will not be fully discussed herein. In Figure 1, the resonant scanner is used in a scanned image display device of the type ^{described in the specification of U.S. Patent 4,934,773} ~~covered in copending U.S. Patent application entitled Miniature Video Display System, filed on July 27, 1987 under serial number 078,295 and assigned to the same assignee as the present~~



~~invention~~ As the display device is described in detail in that application, which is hereby incorporated by reference, only a brief description of the operation will be given here.

In a scanned image type of display device, a row of light emitting devices 10 (which may illustratively be light-emitting diodes) is electrically excited to selectively emit light thereby generating an illuminated line. In Figure 1, the row of LEDs extends perpendicularly into the page.

The light from LED row 10 passes through an optical system schematically illustrated as lens 5, which creates an enlarged virtual image of the LED's. The image is reflected from mirror 30 to an observer's eye 15 as mirror 30 is repetitively oscillated in the direction of arrow 16. By selectively illuminating the LEDs in row 10 as mirror 30 moves, a rectangular raster can be formed which can be observed by the viewer.

The mechanism which moves the mirror is generally termed as a resonant scanner. It consists of a base 20 to which plane mirror 30 is attached by means of a flat spring 34 which extends perpendicularly into the page. Mirror 30 is oscillated by a drive motor consisting of two cylindrical permanent magnets 44 and 45 and two ring



coils 46 and 47. In operation, one of coils 46 and 47, for example coil 47, is excited and the corresponding permanent magnet, 45, is either attracted into coil 47 or repulsed depending on the relative magnetic fields produced by coil 47 and magnet 45. The resulting force causes mirror 30 to pivot around the attachment point with spring 34 so that mirror 30 oscillates in the direction of arrow 16.

The remaining coil (coil 46 in the example) is used as a sensing coil to sense the motion of mirror 30. The electrical signals derived from the motion of magnet 44 relative to coil 46 are used by driving circuitry (not shown) to control the current provided to drive coil 47 in a conventional fashion and as described in the aforementioned Patent No. 4,632,501.

In practice, the mass and geometry of mirror 30 and the spring constant of spring 34 are chosen so that a resonant mass system is formed at the desired operating frequency. In this manner, a large excursion angle for mirror 30 is produced by a driving force which is much lower than would be required if the mirror were driven in a non-resonant fashion.

The problem with the mirror driving system shown in Figure 1 is that the spring forces which cause

the mirror mass 30 to oscillate are also applied to base 20 and any supporting structures attached to base 20. Although mirror 30 is generally quite small, its motion is typically at a sufficiently high frequency that the forces are large in amplitude. These large amplitude forces are transmitted to base 20 causing it to vibrate in response.

Figure 2 shows a partial cross-sectional view of the mirror assembly of the present invention. The elements of Figure 2 which correspond to those of Figure 1 have been given the same numeral designations. In the Figure 2 structure, mirror 30 is part of a balanced assembly with two arms. One arm comprises mirror 30, mirror support 36 and driving coil 46. The other arm consists of weight 40 and permanent magnet 44. The mirror arm is attached to base mounting 21 by means of two flexure springs 32 and 34. Springs 32 and 34 are both flat springs which extend into the page. As will be discussed hereinafter, two springs are used in a crossed arrangement to constrain rotation of the mirror assembly to a single axis.

Mirror 30 is directly attached to a mirror support 36 (which may be comprised of a suitable plastic or other material) by means of adhesive or cement. One end of spring 32 is attached to mirror

support 36 by means of a screw or rivet or other fastener. The other end of spring 32 is attached to base mounting 21 by means of another fastener. A second spring, 34, is also attached to mirror support 36 by fastener 37 and to base 21 by fasteners 39. Although not explicitly shown, rectangular washers would generally be used with fasteners 39 in order to mechanically define the flexing point of the spring. The two flexure springs 32 and 34 act together so that mirror 30 and mirror support 36 effectively pivot around the point 48 at which springs 32 and 34 cross. Under influence of the driving motor, the mirror arm oscillates in the direction of arrow 16 around point 48.

Weight 40 is attached to the one end of spring 42 by means of fastener 43. Spring 42 is also a flat spring extending into the page. The other end of spring 42 is attached to base 21 by means of fastener 45. Weight 40 thus effectively pivots around an intermediate point located on spring 42 between attachment points 43 and 45.

Mirror 30 and weight 40 are driven by a voice-coil type electromagnetic motor consisting of permanent magnet 44 weight 40 and coil 46. Magnet 44 is rigidly secured to weight 40, while the coil 46 is rigidly secured to mirror support 36. Weight

40 is shaped with an overhanging portion 41 which acts to complete the magnetic flux return path and improve the efficiency of the motor. Circuitry is provided (not shown) to supply a sinusoidal current (or other periodic current, such as a square wave or current pulses) to the electrical coil 46. In accordance with one feature of the invention, the electrical connections between coil 46 and the driving circuitry are provided through springs 32 and 34 in order to avoid separate wires which are subject to fatigue from flexing.

The sinusoidal current in coil 46 generates a fluctuating magnet field which causes magnet 44 and coil 46 to be alternately attracted and repelled at the frequency of the current. The frequency of the sinusoidal driving current is chosen so that mirror 30 rotates through an arc segment at the resonant frequency of the spring/mass system consisting of mirror 30 and spring 32. Generally, the desired resonant frequency will depend upon the use of the scanner. In a scanned image display system as previously mentioned, the proper resonant frequency depends on the minimum display refresh rate to eliminate display "flicker". The resonant frequency can be selected in a conventional fashion by choosing the mass and geometry of mirror 30 and the spring constant of spring 32.

Advantageously, the use of the illustrative structure allows a light-weight drive coil to be placed on the mirror assembly rather than requiring a heavy magnet structure to be placed on the mirror assembly. This arrangement, in turn, allows the electromagnetic drive motor to be designed for efficient operation because the permanent magnet structure on the counterbalance arm can be large and heavy in order to produce a high magnetic field strength without contributing to the mass of the mirror arm.

When used in a scanned image display, the illustrative scanner has an additional benefit. Since the effective mirror pivot point 48 is located away from the center of mirror 30, a smaller mirror can be used to produce an optical system with a given "exit pupil". This advantage is illustrated in Figures 3A and 3B which show two display systems each utilizing an oscillating scanner mirror. Elements and locations in Figures 3A and 3B which are equivalent to those elements and locations shown in Figure 2 are given the same numeral designations.

Exit pupil 110 is defined as the area in which the user's eye 15 can be placed so as to see the entire image. In Figure 3A, a display system is constructed with a mirror pivoted near the center. As shown in the figure, the size of the exit pupil

110 is dependent on the arc through which the mirror swings and the geometry of the display. In Figure 3B, an exit pupil which has the same size as the exit pupil in Figure 3A can be achieved with a significantly smaller lens 5 and case size when the mirror is pivoted near one end according to one aspect of the present invention.

Figure 4 shows a partial perspective view of the illustrative embodiment of the resonant scanning unit with an accompanying housing shown in partial phantom detail. Figure 4 illustrates the connection of flexure springs 32, 34 and 42 between mirror 30 and weight 40 and the base mounting 21. In Figure 4, components which are equivalent to those shown in Figure 2 are given the same numeric designations.

Flexure spring 34 is illustratively a U-shaped spring made out of a single layer of flat spring material. Similarly, flexure spring 32 is a single layer flat spring which is mounted between the legs of spring 34 at a right angle to the plane of spring 32. This "crossed" spring design constrains movement of mirror mass 30 to essentially pure rotation whereas the single spring design common in conventional units is subject to undesirable twisting movements. Spring 42 is another U-shaped spring which fastens weight 40 to base 21.

The design of the mirror assembly and counterbalance mass in order to accomplish cancellation of the reaction forces can be carried out in a conventional manner. In particular, in accordance with conventional mechanical design theory, the reaction forces on a mass/spring system can be represented by a pair of force vectors which act at a conceptual "point of percussion". Although the actual moving part will have both mass and rotary moment of inertia these may be modeled as an equivalent point mass located at the point of percussion.

A secondary force vector passes through the point of percussion and the system pivot point and represents centrifugal force. A primary force vector passes through the point of percussion and is perpendicular to the secondary force vector and represents the force needed to translate and rotate the mass about the pivot point.

In operation, in the illustrative resonant scanner, the primary force vector has a relatively large sinusoidal magnitude which causes the mirror to accelerate back and forth (the magnitude of the force is greatest at the extreme ends of travel of the mirror). This force depends only upon the equivalent mass of the mirror assembly and the amplitude of mirror travel and, with proper pivot

point placement and design, can be substantially cancelled by the reaction forces generated by the counterbalance mass. Specifically, the geometry of the mirror and counterbalance mass must be adjusted so that the primary force vectors are co-linear. In an illustrative embodiment constructed in accordance with the invention and operating at a scan frequency of 50 Hz., it has been found that this force is approximately 42 grams-force (gmf). It has been found that with a mirror mass of 3.36 grams, a counterbalance mass of 10.95 grams has produced effective cancellation of this force.

A much smaller drag force also acts upon the mirror assembly. This force is primarily a velocity-proportional force due to air resistance. In the previously mentioned illustrative embodiment constructed in accordance with the principles of the invention, the "Q" value for the mirror assembly alone is approximately 100 resulting in a drag force of about 0.4 gmf (the "Q" value is a measure of damping and has to do with the sharpness of the resonant peak). In order to make up for the energy lost due to the drag forces, voice coil motor 46 supplies a force to move mirror 30. If the drive force is a sine wave it can be made to substantially balance the previously-mentioned force resulting from drag.

Similarly, a drag force also acts on the counterbalance assembly. In the preferred embodiment described above, this latter force is approximately 0.2 gmf, corresponding a to "Q" of 200 for the counterbalance mass alone. The "Q" of the mirror assembly alone is lower because of its larger surface area. To minimize any extraneous forces resulting from imperfectly cancelled motor forces, in the illustrative embodiment, the motor torque exerted on the mirror and the counterbalance mass by the voice coil motor must be in the ratio of 0.4/0.2. The geometry of the illustrative embodiment has been designed to substantially accomplish this result.

Although a sinusoidal drive force applied in the correct ratio theoretically results in substantially zero net drive-related forces applied to the base, a non-sinusoidal drive force can also be used. If the drive force is periodic but not sinusoidal, a small net force will be applied to the base, but this force may be acceptable in view of simplifications possible in the motor drive circuitry.

Further, since the equivalent mass of the mirror moves in a slight arc rather than in a straight line, there is also secondary force vector (mentioned earlier) caused by the transverse motion of the equivalent mass. This secondary force vector

represents centrifugal force. The magnitude of this secondary force vector is substantially sinusoidal and has a frequency twice the frequency of the mirror motion. The double-frequency force will cause a slight vibration of the device base or, if the base is prevented from moving, the reaction force will be transferred to the supporting structure. A similar force acts on the counterbalance mass assembly. With the mirror and counterbalance configuration shown in the illustrative embodiment, the double-frequency forces for the mirror assembly and the counterbalance mass assembly are in the same direction and, consequently, do not cancel. However, as the extent of the transverse movement of the mirror and counterbalance masses is very small for example, in the illustrative embodiment approximately $\pm 42 \text{ um}$ for the mirror and $\pm 5 \text{ um}$ for the counterbalance mass, the vibration which is produced is acceptable. When incorporated in a display of total weight 42 gm, the resulting case vibration would be $\pm 7 \text{ um}$.

It is also possible to mount the scanner assembly in a compliant mount which can allow slight motion of the display case so that vibrations caused by unbalanced forces do not cause vibration of the structure to which the display is attached.

Figure 4 also shows the electrical connections of coil 46 through flexure springs 32 and 34. Since two separate flexure springs, 32 and 34, are used to support mirror 30 these springs may also be used in order to carry electrical current to coil 46 and, thus, eliminate the use of separate wires which may be subject to breakage due to repeated flexing. In particular, one electrical lead, 50, of coil 46 is attached to flexure spring 34 by means of fastener 37. Another electrical lead, 55, is attached to flexure spring 32 by means of fastener 35. Electrical connections to coil 46 can be completed by making appropriate electrical connections to the other ends of the flexure springs 32 and 34 at fasteners 33 and 39, respectively. Current is thus carried along the flexure springs directly to coil 46.

Figures 5-8 show an alternative embodiment of a resonant scanner unit that uses a preferred construction of the voice coil motor. This preferred construction increases motor efficiency by achieving higher magnetic field strength in the air gap. With a motor construction as shown in Figures 2 and 4, inefficiency results because the air gap between the inside diameter of toroidal coil 46 and magnet 44 must be sufficient to accommodate the varying arcs through which mirror 30 and weight 40

move. The relatively large tolerance which is required in order to prevent physical collisions results in high flux leakage and low field strength in the air gap, and, thus, in poor motor efficiency.

The motor design shown in Figures 5-8 improves motor efficiency by optimizing the magnetic circuit to reduce leakage flux. Parts of the assembly which remain the same as the embodiments shown in Figures 2 and 4 are designated with the same numerals. In particular, the toroidal-shaped coil 46 shown in Figure 4 is replaced by a rectangular coil 66 shown in Figures 5 and 6. Instead of a single cylindrical magnet 44 as shown in Figure 4, weight 40 has been modified to have an "E" shape with three fingers, 70, 72 and 74 shown in the cross-sectional view of Figure 7. Central finger 72 fits into the rectangular opening 73 in coil 66 as shown in Figures 7 and 8. The two side fingers 70 and 74 are provided with magnets 73 and 75 which lie on the outside of coil 66 as shown in Figures 7 and 8.

Also shown in Figure 5 is a slot 76 which is cut in weight 40. This slot, as will hereinafter be described, is used to accommodate a mechanical sensor that senses the position of mirror 30 and generates electrical signals which control the driving current to ensure that mirror 30 and weight

40 oscillate at the desired resonant frequency.

Figures 6-8 also shown an improved mechanism for attaching spring 42 to weight 40. As shown, spring 42 is clamped between two clamping members 45 and 47. Clamp members 45 and 47 have slots 51 (shown in Figure 6) which allow the members to be slid over fasteners 43. The ends of spring 42 which are fastened by fasteners 43 are not slotted, thus the distance between the wieght 40 and base 21 is mechanically fixed. However, clamping members 45 and 47 can be moved relative to weight 40, thus effectively changing the attachment point of spring 42 to weight 40. Thus, the effective spring length can be changed for the purposes of adjusting the resonant frequency without changing the basic geometry of the device.

Figure 9 is a partial cross-section of the resonant scanning unit of Figures 5-8 fitted with a position sensor mechanism. The main components of this mechanism are also depicted in the partial exploded view shown in Figure 10. The sensor mechanism consists of a "flag" 80 which is mounted on one end of rectangular coil unit 66. When the unit is assembled, flag 80 extends between the two arms of LED/photocell sensing unit 90. As shown in Figure 10, sensing unit 90 consists of a mounting bracket 92 which is affixed to the scanner housing

as shown in Figure 9. Two arms 94 and 96 extend from the bracket 92 and lie on either side of flag 80. An LED device 98 is mounted on arm 94 and a photodiode 100 is mounted on arm 96.

In operation, when mirror 30 rotates through an angle which exceeds approximately 70% of the maximum normal operating angle, light emitted from LED 98 is sensed by photodiode 100 which thereupon generates an electrical signal. When the angle of rotation of mirror 30 is less than approximately 70% of the maximum normal operating angle, flag 80 is interposed between LED 98 and photodiode 100, in turn, preventing light emitted from LED 98 from reaching diode 100. The signal emitted from diode 100 thereupon ceases. Consequently, as mirror 30 and weight 40 oscillate, an oscillating electrical signal is developed by photodiode 100. This oscillating signal is used to control the driving electronics which provide the current to the coil 66 of the electromagnetic driving motor.

A schematic block diagram of the driving circuit electronics is shown in Figure 11. The basic components of the circuit consists of a comparator 102, a phase-locked loop 104, an automatic gain control circuit 106 and a power amplifier 108. The components are arranged in a conventional frequency control loop. More particularly, the oscillating

output signal developed by photodiode 100 is provided to one input of comparator 102. Comparator 102 compares the voltage signal level to a reference voltage in order to standardize the waveform and sharpen the zero crossing points. The output of the comparator is a pulse-train signal which is used to drive the remainder of the circuitry.

The output from comparator 102 is provided to a conventional phase-locked loop circuit 104 which is adjusted to maintain the frequency of oscillation at the desired value. The operation of such a phase-locked loop is conventional and will not be explained hereinafter in detail. Circuit 104 generates control signals which control the power amplifier.

The output of comparator 102 is also provided to a conventional automatic gain control circuit 106 which generates a magnitude control signal.

The control signals generated by phase-locked loop circuit 104 and AGC circuit 106 are provided to power amplifier which provides the driving current to the voice coil and completes the feedback loop.

Figure 12 of the drawing shows an illustrative embodiment of the resonant scanning unit incorporated into a miniature display device. The miniature display device is of the type described in detail in aforementioned ~~pending~~ U.S. Patent



^{4,934,773}
~~application serial number 078,295.~~ The operation and construction of the display device is discussed in detail in that application which is hereby incorporated by reference, and will not be repeated in detail herein for clarity. The display device consists of a base 10 on which the various optical components which comprise the display are mounted. At one end of base 10 is mounted the header block 5 in which an array of light-emitting devices 15 (such as light-emitting diodes) is attached. Generally, such an array may be a linear array comprising two rows of devices which are staggered in order to compensate for gaps between the devices. The devices are covered by a clear cover plate 17.

Light emitted from devices 15 is projected on mirror 30 by means of an optical system which consists of housing 18 in which are mounted lenses 19 and 23. In accordance with the principles set forth in the aforementioned ^{Patent 4,934,773} ~~U.S. patent~~ application ~~serial no. 078295~~ the lens system projects the image of array 15 via mirror 30.

Mirror 30 is actuated by providing a periodic current via leads 50 and 55 (shown in Figure 4) to coil 46, causing mirror 30 and weight 40 to oscillate. The oscillation of mirror 30, in turn, creates a raster image from linear array 15.



Having thus described one preferred embodiment of the present invention it will be apparent to those skilled in the art that various modifications and alterations are possible without departing from the spirit and scope of the invention. For example, instead of the pair of flexure springs used to support the mirror assembly, other conventional arrangements such as four-bar linkages (in which each end of the mirror is attached to the base by means of a separate link) may be used without departing from the spirit and scope of the invention. Similarly, a different geometrical arrangement can be used in which the mirror is attached to the base at the center rather than at one end. The invention is not intended to be limited to the preferred embodiment disclosed above. It is limited in scope by the following claims.

THE CLAIMS DEFINING THE INVENTION ARE AS FOLLOWS.

1. A resonant electromechanical scanning unit comprising;
 - a base;
 - a mirror;
 - first spring means connecting said mirror to said base so as to allow said mirror to oscillate relative to said base, said mirror and said first spring means forming a first spring/mass system having a first mechanical resonant oscillation frequency and transferring a first reaction force to said base;
 - a counterbalance mass;
 - second spring means connecting said counterbalance mass to said base so as to allow said counterbalance mass to oscillate relative to said base, said counterbalance mass and said second spring means forming a second spring/mass system having a second mechanical resonant oscillation frequency substantially equal to said first mechanical resonant oscillation frequency and transferring a second reaction force to said base; and
 - driving motor means for imparting motion to at least one of said mirror and said counterbalance mass, said first spring means and said second spring means being connected to said base so that said first reaction force and said

second reaction force substantially cancel at said base.

2. A resonant electromechanical ^{scanning unit} ~~scanner~~ according to Claim 1 wherein said first spring means comprises a first flexure spring and a second flexure spring, said first and second flexure springs connecting said mirror to said base and lying in different planes.
3. A resonant electromechanical ^{scanning unit} ~~scanner~~ as set forth in Claim 1 wherein said first and second spring means comprise flat flexure springs.
4. A resonant electromechanical ^{scanning unit} ~~scanner~~ as set forth in Claim 1 wherein said driving motor means comprises a voice-coil electromagnetic motor.
5. A resonant electromechanical ^{scanning unit} ~~scanner~~ as set forth in Claim 4 wherein said voice-coil electromagnetic motor comprises an electrically conductive coil mounted on said mirror, a permanent magnet mounted on said counterbalance mass and means to form a magnetic circuit between said coil and said magnet.



6. A resonant electromechanical ^{scanning unit} ~~scanner~~ as set forth in Claim 4 wherein said voice-coil electromagnetic motor comprises an electrically conductive coil mounted on said counterbalance mass and a permanent magnet mounted on said mirror.
7. A resonant electromechanical ^{scanning unit} ~~scanner~~ as set forth in Claim 5 wherein said first spring means comprises at least two separate springs, each of which is electrically conductive said springs being connected to said electrically conductive coil so as to comprise two electrical connections to said electrically conductive coil.
8. A resonant ^{electromechanical scanning unit} ~~scanner~~ as set forth in Claim 1 further comprising means for detecting the position of said mirror.
9. A resonant electromechanical scanning unit comprising;
- a base;
 - a mirror;
 - a first spring means connecting said mirror to said base so as to allow said mirror to oscillate about a first pivot point relative to



said base, said mirror and said first spring means forming a first spring/mass system having a first mechanical resonant oscillation frequency and transferring a first reaction force to said base;

a counterbalance mass;

a second spring means connecting said counterbalance mass to said base so as to allow said counterbalance mass to oscillate about a second pivot point relative to said base, said counterbalance mass and said second spring means forming a second spring/mass system having a second mechanical resonant oscillation frequency substantially equal to said first mechanical resonant oscillation frequency and transferring a second reaction force to said base; and

a voice coil driving motor mounted on said mirror and said counterbalance mass for simultaneously imparting opposite motions to said mirror and to said counterbalance mass, said first pivot point being located on said base relative to said second pivot point so that said first reaction force and said second reaction force substantially cancel at said base.

10. A resonant electromechanical ^{scanning unit} ~~scanner~~ according to Claim 9 further comprising a third spring



connected between said mirror and said base,
said first and third springs lying in different
planes.

11. A resonant electromechanical ^{scanning unit} ~~scanner~~ as set forth in Claim 10 wherein said first and third springs are flat flexure springs.
12. A resonant electromechanical ^{scanning unit} ~~scanner~~ as set forth in Claim 10 wherein said voice-coil driving motor comprises an electrically conductive coil and a permanent magnet.
13. A resonant electromechanical ^{scanning unit} ~~scanner~~ as set forth in Claim 12 wherein said electrically conductive coil has two leads and said first spring is connected to one of said leads and said third spring is connected to the other of said leads so as to comprise two electrical connections to said electrically conductive coil.
14. A resonant electromechanical ^{scanning unit} ~~scanner~~ according to Claim 9 further comprising a light source, a photodetector for detecting light generated by said light source and means attached to said mirror and responsive to the movement of said mirror for periodically preventing light from



said light source from reaching said photodetector.

15. A miniature optical display device for generating a raster image to display selected information, said display^{device} comprising:
- a linear array of light-emitting devices;
 - a mirror;
 - an optical system located between said linear array and said mirror, said optical system projecting a virtual image of said linear array via said mirror;
 - a base;
 - first spring means connecting said mirror to said base so as to allow said mirror to oscillate relative to said base, said mirror and said first spring means forming a first spring/mass system having a first mechanical resonant oscillation frequency and imparting a first reaction force to said base;
 - a counterbalance mass;
 - second spring means connecting said counterbalance mass to said base so as to allow said counterbalance mass to oscillate relative to said base, said counterbalance mass and said second spring means forming a second spring/mass system having a second mechanical resonant



oscillation frequency substantially equal to said first mechanical resonant oscillation frequency and imparting a second reaction force to said base; and

driving motor means for imparting opposite motions to said mirror and to said counterbalance mass whereby said virtual image of said linear array is swept by the motion of said mirror to produce a raster display, said first and second reaction forces substantially cancelling at said base.

16. A miniature optical display ^{device} ~~unit~~ according to Claim 15 wherein said first spring means comprises a first flexure spring and a second flexure spring, said first and second flexure springs connecting said mirror to said base and lying in different planes.

17. A miniature optical display ^{device} ~~unit~~ according to Claim 15 wherein said first and second spring means comprise flat flexure springs.

18. A miniature optical display ^{device} ~~unit~~ according to Claim 16 wherein said driving motor means comprises a voice-coil electromagnetic motor having an electrically conductive coil and a permanent magnet.



19. A miniature optical display ^{device} ~~unit~~ according to Claim 18 wherein said first and second flexure springs are electrically conductive and are connected to said electrically conductive coil so as to comprise two electrical connections to said electrically conductive coil.
20. A miniature optical display device for generating a raster image to display selected information, said display comprising:
- a linear array of light-emitting devices;
 - a mirror;
 - an optical system located between said linear array and said mirror, said optical system projecting a virtual image of said linear array via said mirror;
 - a base;
 - a first and a second flexure springs connecting said mirror to said base;
 - a counterbalance mass;
 - a third flexure spring connecting said counterbalance mass to said base so that said counterbalance mass is adjacent said mirror;
 - an electrically conductive rectangular coil having an inner dimension and an outer dimension, said coil being mounted on said mirror;

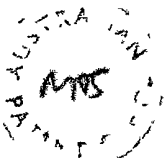

a permanent magnet structure mounted on said counterbalance mass having a first, a second and a third finger, said first and third fingers being configured to pass on either side of said coil when said mirror and said counterbalance mass move relative to each other, said second finger configured so as to fit within said
5 inner dimension of said coil; and

driving circuit means for providing a periodic current to said coils so as to cause said mirror and said counterbalance mass to angularly rotate in opposite directions back and forth in arc segments about fixed pivot points at said base so that the reaction force of said mirror at said base is substantially cancelled by the
10 reaction force of said counterbalance mass at said base.

21. A miniature optical display device according to claim 20 further comprising a light source, a photodetector arranged to receive light from said light source and a flag member attached to said mirror, said flag member moving between said light
15 source and said photodetector to block light from said light source from reaching said photodetector when said mirror rotates through a predetermined angle.

22. In a miniature display apparatus which generates a raster image from a linear array of light-emitting devices, said display device
20



having a base, a mirror, a first spring connecting said mirror to said base at a first point and a driving mechanism for oscillating said mirror relative to said base, the reaction force generated by the motion of said mirror being transmitted through said spring to said base, a method for reducing the vibration of said base due to said reaction force, said method comprising the steps of:

- A. mounting a counterbalance mass on said base by means of a second spring attached to said base at a second point, the mechanical resonant frequency of said mirror/first spring system being substantially equal to the mechanical resonant frequency of said counterbalance mass/ second spring system;
- B. providing a driving mechanism to oscillate said counterbalance mass, the reaction force produced by the oscillation of said counterbalance mass being conducted through said second spring to said base, and
- C. positioning said first spring attachment point relative to said second spring attachment point so that the reaction force of said mirror is substantially cancelled by the reaction force of said counterbalance mass.

23. A resonant electromechanical scanning unit substantially as hereinbefore described with reference to Figures 2 to 12.

5

10



15

DATED this 4th day of October, 1991.

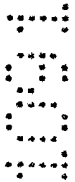

REFLECTION TECHNOLOGY, INC.

By its Patent Attorneys

20 Davies & Collison

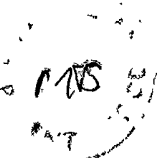

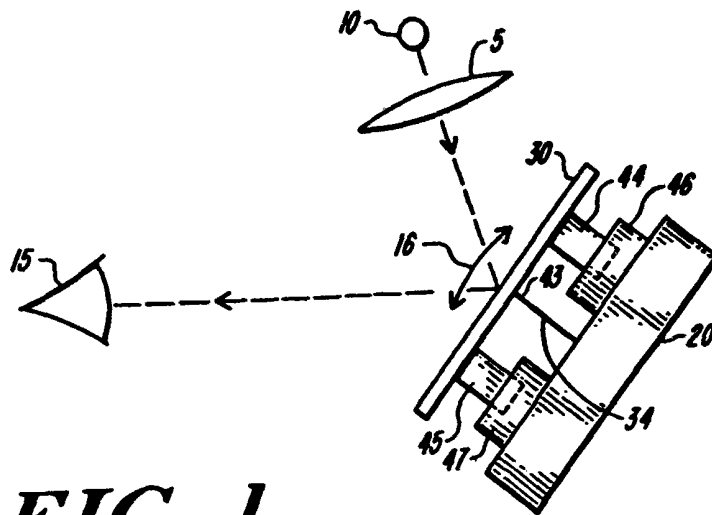

FIG. 1
(PRIOR ART)

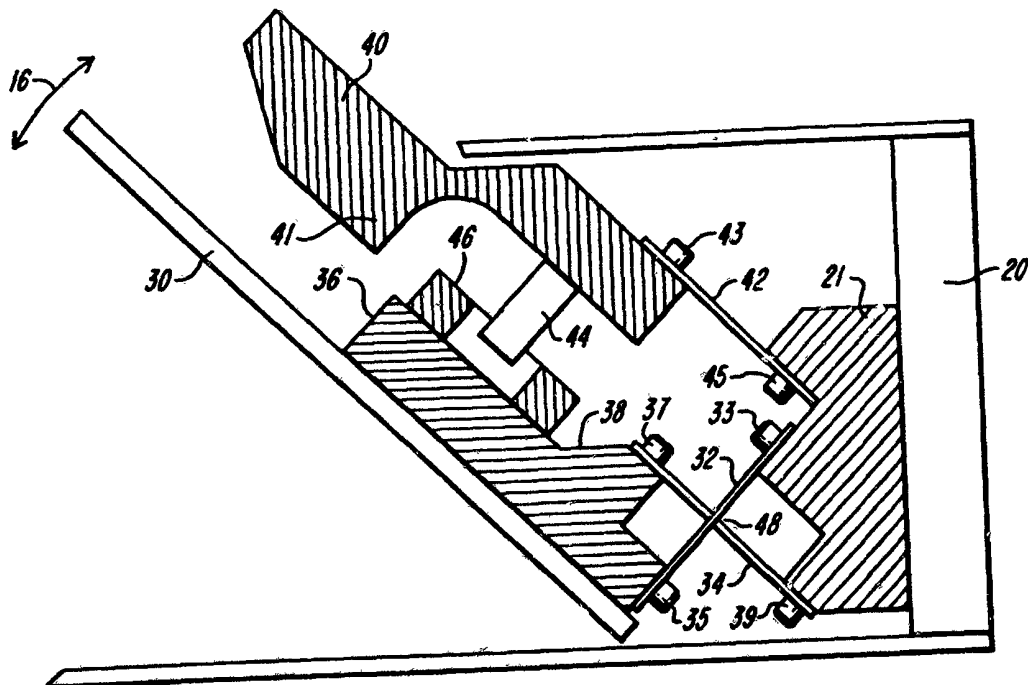

FIG. 2

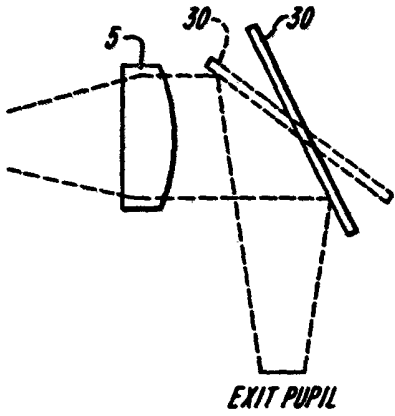

FIG. 3A

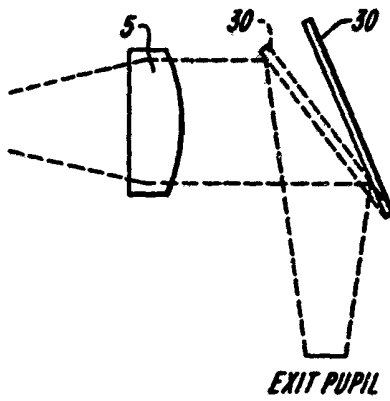

FIG. 3B

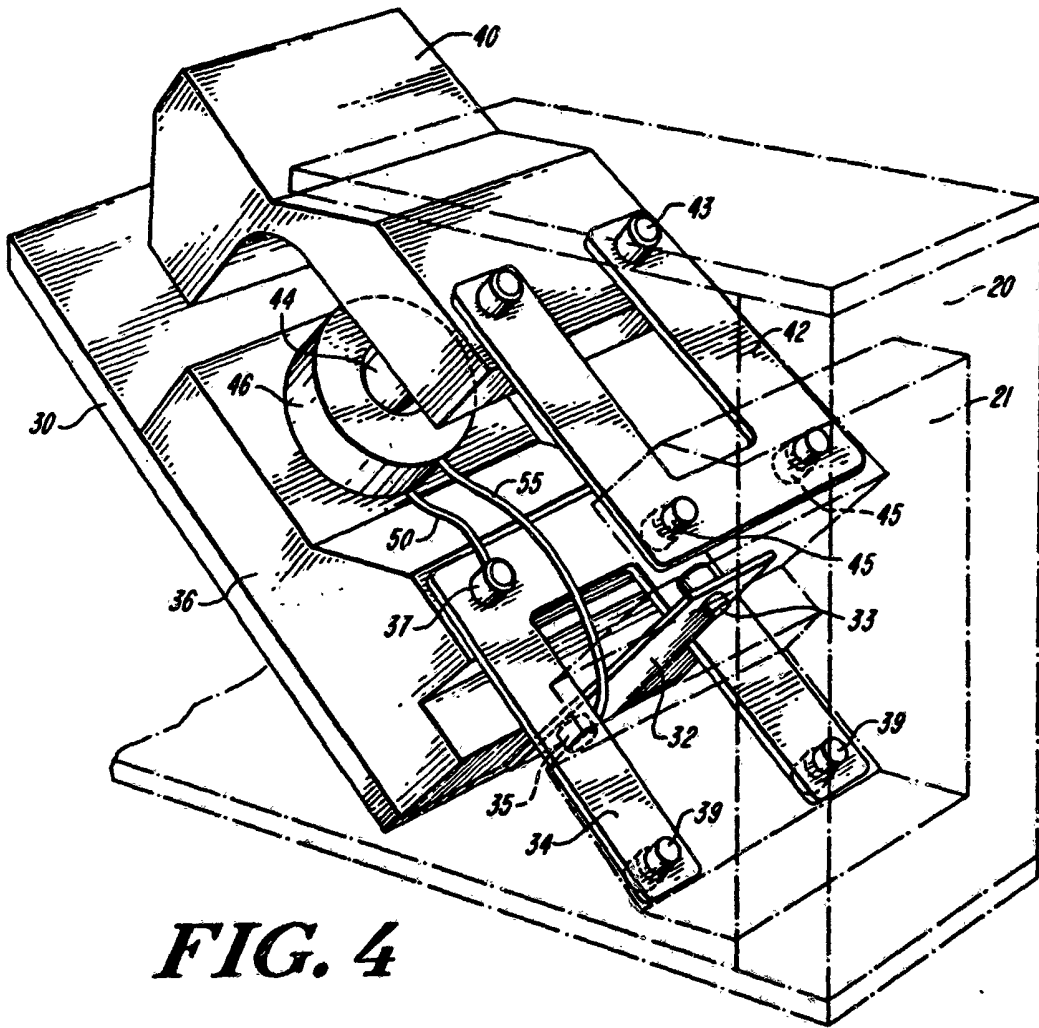

FIG. 4

29986/89

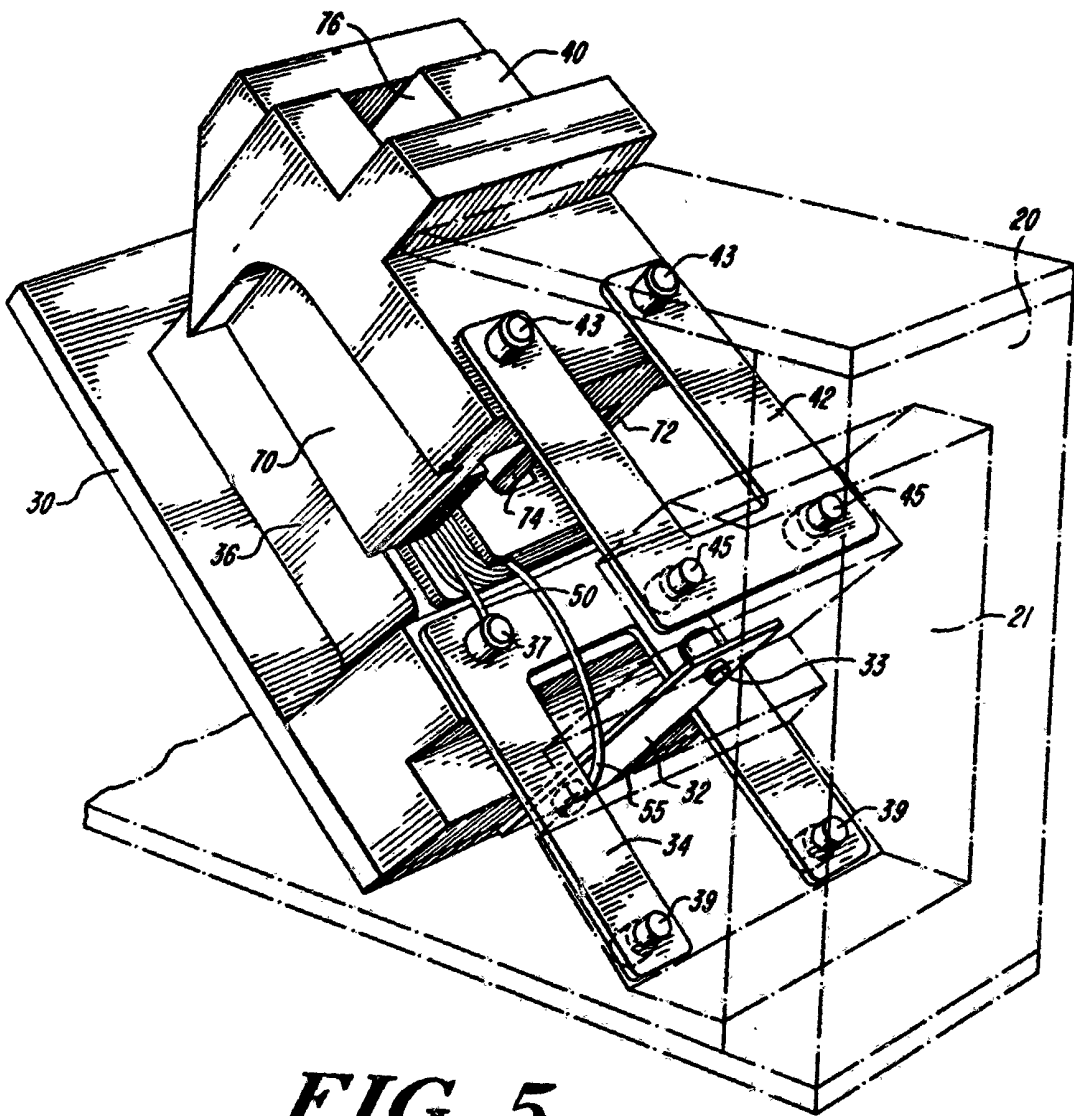

FIG. 5

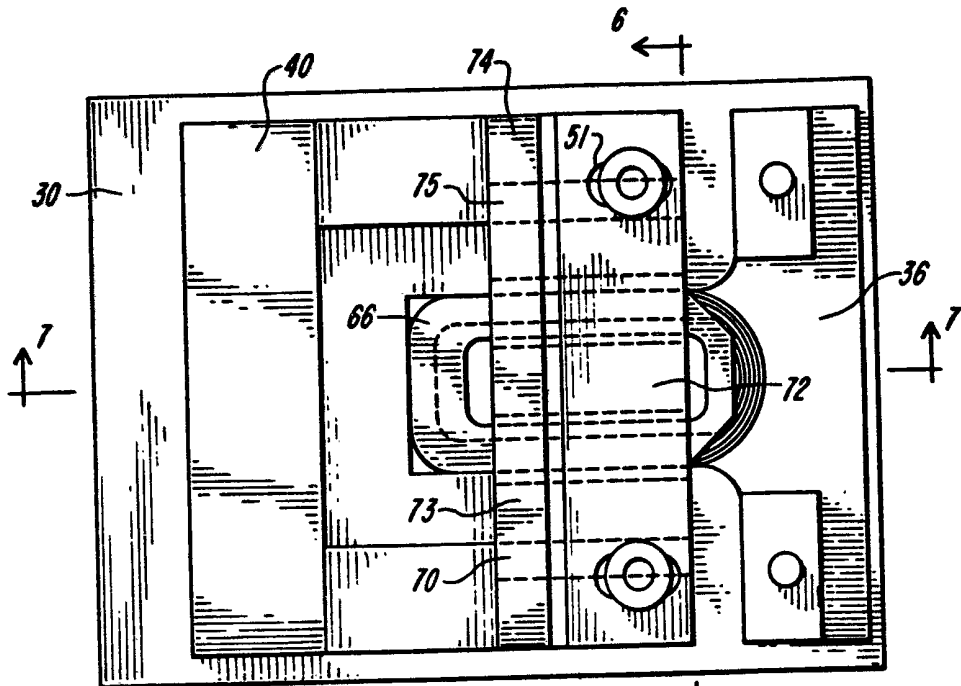

FIG. 6

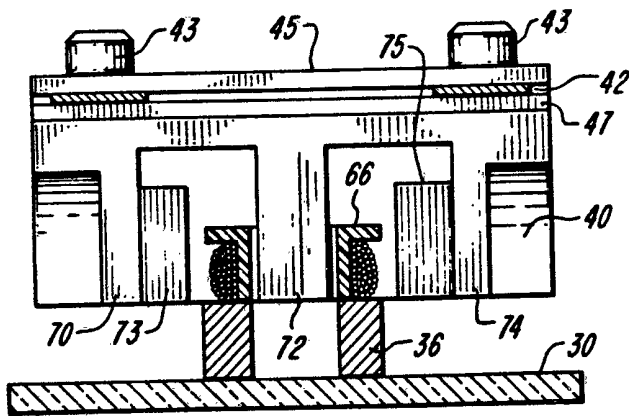

FIG. 7

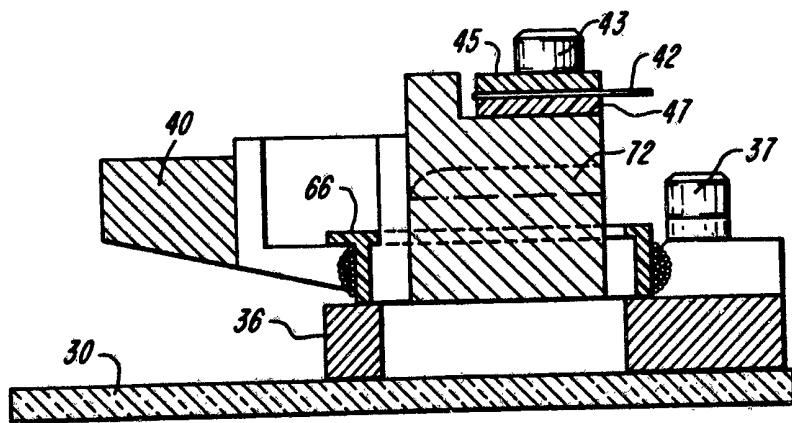

FIG. 8

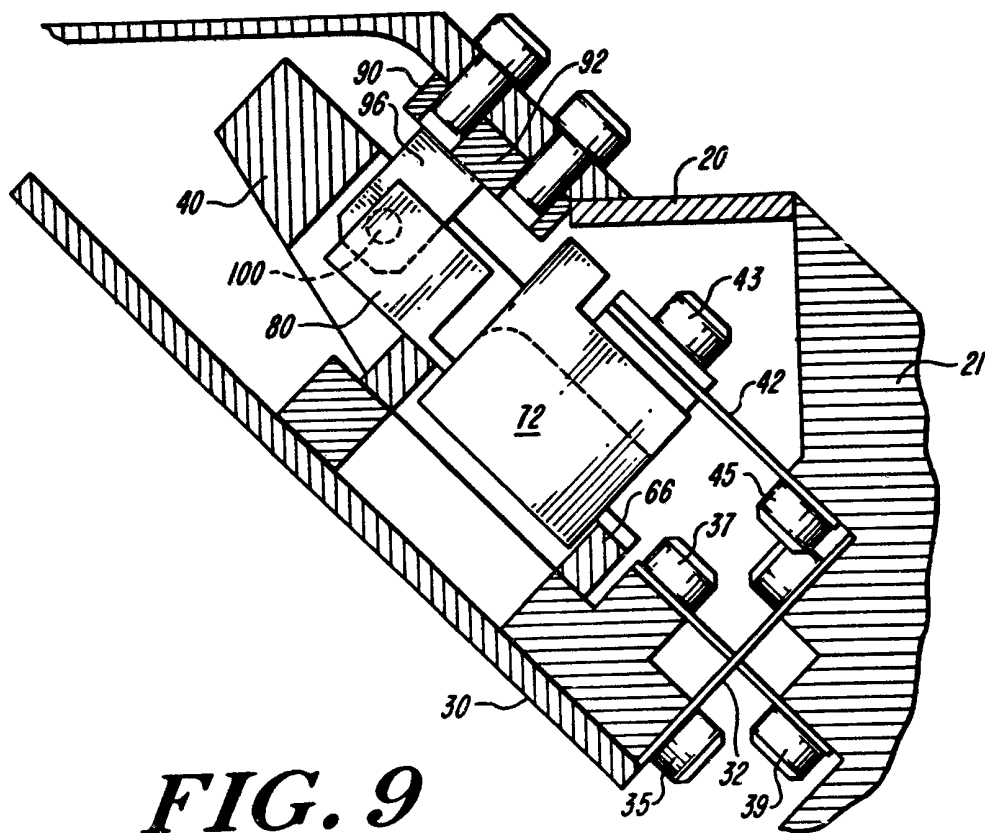

FIG. 9

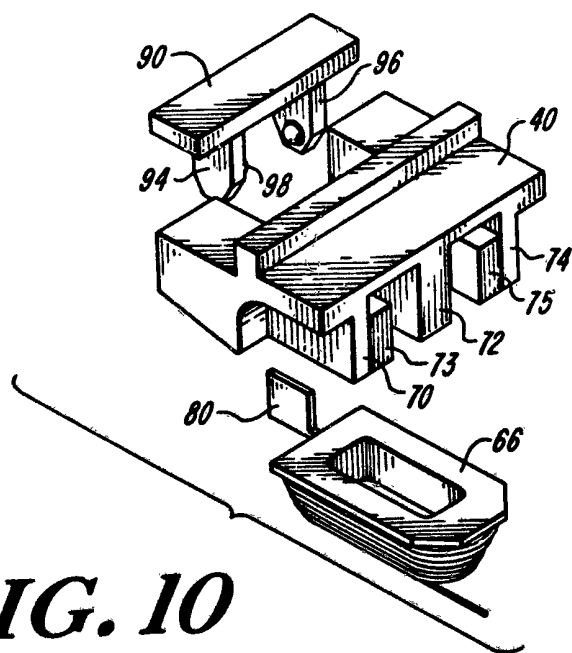

FIG. 10

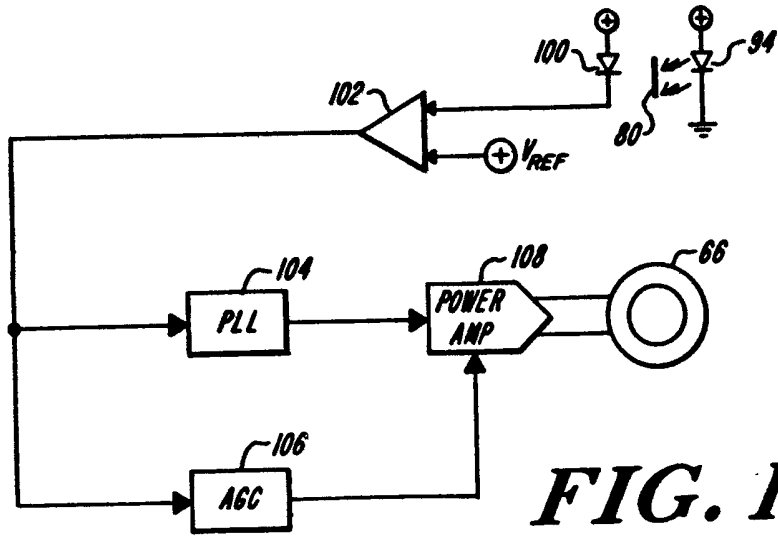

FIG. 11

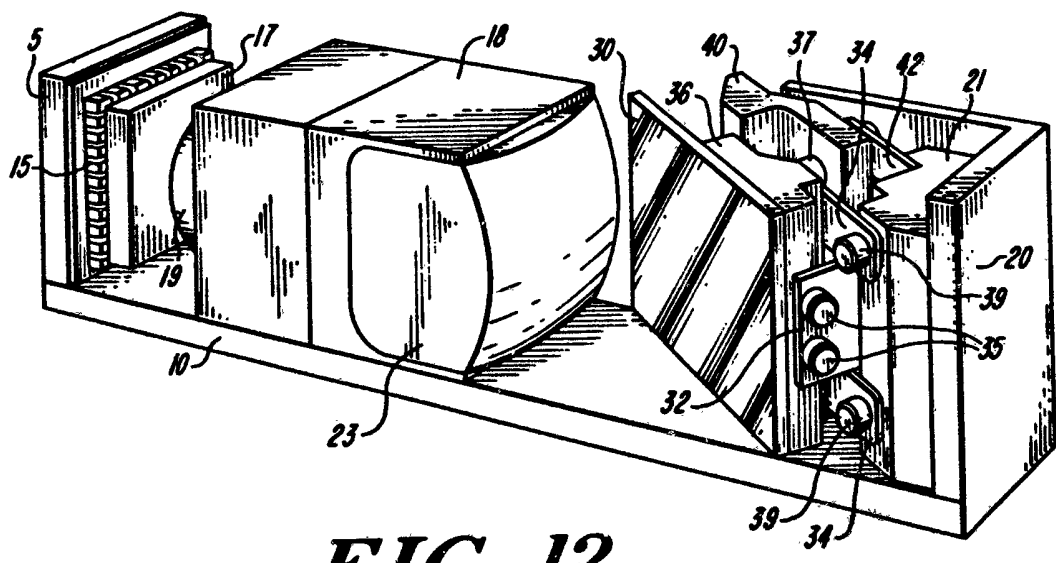

FIG. 12