



- (51) **International Patent Classification:**  
A61M 16/06 (2006.01)
- (21) **International Application Number:**  
PCT/US2011/044229
- (22) **International Filing Date:**  
15 July 2011 (15.07.2011)
- (25) **Filing Language:** English
- (26) **Publication Language:** English
- (30) **Priority Data:**  
61/365,149 16 July 2010 (16.07.2010) US  
61/465,422 18 March 2011 (18.03.2011) US
- (71) **Applicant (for all designated States except US):** HONEYWELL INTERNATIONAL, INC. [US/US]; Patents Services Group AB2, 101 Columbia Road, P.O. Box 2245, Morristown, NJ 07962 (US).
- (72) **Inventors; and**
- (75) **Inventors/Applicants (for US only):** GAUTHIER, Felix [CA/CA]; 2615 Letouneux #5, Montreal, Quebec H1V 2P3 (CA). LAMONTAGNE, Marc [CA/CA]; 250 Lanoue, Repentigny, Quebec J6A 1W1 (CA). DANG DUC, Bach [CA/CA]; 7450 Tunisie Av., Brossard, Quebec J4W 2J4 (CA).
- (74) **Agents:** FAIRCHILD, Jeffery, N. et al.; Wood, Phillips, Katz, Clark & Mortimer, 500 West Madison Street, Suite 3800, Chicago, IL 60661 (US).

- (81) **Designated States (unless otherwise indicated, for every kind of national protection available):** AE, AG, AL, AM, AO, AT, AU, AZ, BA, BB, BG, BH, BR, BW, BY, BZ, CA, CH, CL, CN, CO, CR, CU, CZ, DE, DK, DM, DO, DZ, EC, EE, EG, ES, FI, GB, GD, GE, GH, GM, GT, HN, HR, HU, ID, IL, IN, IS, JP, KE, KG, KM, KN, KP, KR, KZ, LA, LC, LK, LR, LS, LT, LU, LY, MA, MD, ME, MG, MK, MN, MW, MX, MY, MZ, NA, NG, NI, NO, NZ, OM, PE, PG, PH, PL, PT, RO, RS, RU, SC, SD, SE, SG, SK, SL, SM, ST, SV, SY, TH, TJ, TM, TN, TR, TT, TZ, UA, UG, US, UZ, VC, VN, ZA, ZM, ZW.
- (84) **Designated States (unless otherwise indicated, for every kind of regional protection available):** ARIPO (BW, GH, GM, KE, LR, LS, MW, MZ, NA, SD, SL, SZ, TZ, UG, ZM, ZW), Eurasian (AM, AZ, BY, KG, KZ, MD, RU, TJ, TM), European (AL, AT, BE, BG, CH, CY, CZ, DE, DK, EE, ES, FI, FR, GB, GR, HR, HU, IE, IS, IT, LT, LU, LV, MC, MK, MT, NL, NO, PL, PT, RO, RS, SE, SI, SK, SM, TR), OAPI (BF, BJ, CF, CG, CI, CM, GA, GN, GQ, GW, ML, MR, NE, SN, TD, TG).

**Declarations under Rule 4.17:**

— of inventorship (Rule 4.17(iv))

**Published:**

— without international search report and to be republished upon receipt of that report (Rule 48.2(g))

(54) **Title:** REPLACEMENT LENS CARTRIDGE

Fig. 25

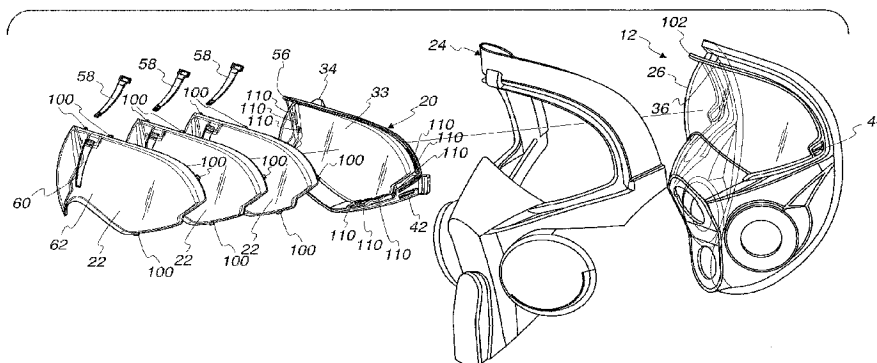

(57) **Abstract:** A replaceable lens cartridge (10) is provided for use with a face mask (12). The cartridge (10) includes a plurality of molded lenses (22), each lens (22) sized to extend over both eyes of a wearer and having a curved shape and a plurality of catches (40,52, 100); and a molded carrier (20) mounting the lenses (22) in stacked arrangement, the carrier having a first set of catches (38,50, 110) receiving the catches (40,52,100) on one of the lenses (22).



## REPLACEMENT LENS CARTRIDGE

## CROSS-REFERENCE TO RELATED APPLICATIONS

**[0001]** This application claims the benefit of the filing date of U.S. Provisional Serial No. 61/365,149, filed July 16, 2010 and U.S. Provisional Serial No. 61/465,422, filed March 18, 2011, both of which are hereby incorporated by reference in their entirety.

## FEDERALLY SPONSORED RESEARCH OR DEVELOPMENT

**[0002]** Not Applicable.

## MICROFICHE/COPYRIGHT REFERENCE

**[0003]** Not Applicable.

## FIELD

**[0004]** This replacement lens cartridge is mostly directed to protective face and eyewear such as is worn in the shipyard industry, but could be suitable for different types of construction sites where sandblasting/shot blasting is performed.

## BACKGROUND

**[0005]** In order to build or repair ships, workers have to crawl and work in very tight space (vessel, portal, etc.) where their protective equipment (respirator) is subjected to grit rebound. Those rebounds will damage the lens of their respirator and blur their vision. They are currently using a respirator that only provides a 4½ inch x 2¾ inch flat field of view. This tunnel vision adds to the claustrophobic effect of their work environment. Plus, it requires more

-2-

head movement from the worker to see where he is aiming with the blasting gun. Workers would benefit from a larger field of vision.

The permanent lens of the above-described respirator is protected by a disposable lens pack in a cartridge that provides 2 to 4 layers of protection depending on the lens thickness. There is foam that surrounds the lenses in the cartridge. This cartridge is inserted in a square frame on the face mask of the respirator and secured in place by a door mounted on a hinge. The disposable lens are made of glass, tempered or untempered, and can be laminated for heavy blasting. As the grit rebound wears the disposable lens, they are removed from the cartridge by pulling glued tab (two on each lens). Because the lenses are made of glass, the cartridge adds a lot of weight in front of the respirator and workers have complaint about the front heaviness of the respirator. This could result in neck pain.

#### SUMMARY

**[0006]** In accordance with one feature, a replaceable lens cartridge is provided for use with a face mask. The cartridge includes a plurality of molded lenses, each lens sized to extend over both eyes of a wearer and having a curved shape and a plurality of catches; and a molded carrier mounting the lenses in stacked arrangement, the carrier having a first set of catches receiving the catches on one of the lenses.

**[0007]** In one feature, the carrier has a second set of catches receiving the catches of the other of the lenses, the first set of catches having locations on the carrier that differ from locations of the second set of catches on the carrier.

**[0008]** As one feature, the lens cartridge further includes a third molded lens sized to extend over both eyes of a wearer and having a curved shape and a plurality of catches. The carrier mounts the third lens in stacked relation with

the other two lenses and has a third set of catches receiving the catches of the third molded lens, the third set of catches having locations on the carrier that differ from the locations of the first and second set of catches on the carrier.

**[0009]** According to one feature, the plurality of catches on each lens are located along a perimeter of the lens, with the catches of each lens being spaced along the perimeter from the catches of the other lens with the lenses mounted in stacked arrangement on the carrier.

**[0010]** In one feature, the plurality of catches on each lens comprises at least four projections extending from the perimeter of the lens, and the first and second set of catches on the carrier includes a matching number of reliefs on the carrier, each relief receiving one of the projections.

**[0011]** As one feature, the curved shape of each of the lenses differs from one lens to the next to compensate for optical distortions produced by the lenses mounted in stacked arrangement on the carrier.

**[0012]** According to one feature, the lens cartridge further includes a plurality of pull tabs, each tab corresponding to one of the lenses, centered on the lens to overlie a nose bridge of the lens and attached to the lens to allow removal of the lens from the carrier when the tab is pulled by a wearer.

**[0013]** As a further feature, each of the lenses includes a recess underlying the pull tab to receive the pull tab and prevent unwanted interference between the pull tab and any adjacent lens.

**[0014]** According to one feature, the carrier further includes a fixed lens underlying the lenses mounted in stacked arrangement on the carrier, the fixed lens having a curved shape.

**[0015]** In one feature, the carrier further includes a peripheral lip that extends over perimeters of the lenses mounted in stacked arrangement on the carrier. In a further feature, the first set of catches is formed in the peripheral lip. In yet a further feature, the carrier has a second set of catches formed in the peripheral lip and receiving the catches of the other of the lenses, the first

-4-

set of catches having locations on the peripheral lip that differ from locations of the second set of catches on the peripheral lip.

**[0016]** In one feature, there is an air gap between each of the lenses.

**[0017]** As one feature, each lens includes one of a cylindrical lens, a spherical lens, or a toric lens.

**[0018]** According to one feature, the carrier further includes a plurality of mount catches for engagement with a face mask.

**[0019]** Other features and advantages of the invention will become apparent from a review of the entire specification, including the appended claims and drawings.

#### BRIEF DESCRIPTION OF THE DRAWINGS

**[0020]** Fig. 1 is a perspective view from the front and below of a lens cartridge;

**[0021]** Fig. 2 is a perspective view of a respirator for use with the lens cartridge and worn by a worker with additional protective garments;

**[0022]** Fig. 3 is a section view of the cartridge of Fig. 1 mounted on the respirator of Figs. 2 and taken along the centerline of the cartridge and respirator;

**[0023]** Fig. 4 is an enlarged, front perspective view of a portion of the respirator of Fig. 2;

**[0024]** Fig. 5 is a perspective view from the rear of the cartridge of Fig. 1 and showing an optional feature;

**[0025]** Figs. 6A-6G are a sequence of figures showing the steps for mounting and dismounting the cartridge of Fig. 1 onto the respirator of Figs. 2 and 3, and for removing replacement lenses carried in the cartridge;

**[0026]** Fig. 7A and 7B are broken, perspective views from the front and above showing a selected portion of a carrier of the cartridge and a lens carried

in the cartridge, with Fig. 7A showing the lens being inserted and Fig. 7B showing the lens in an inserted position;

**[0027]** Figs. 8A and 8B are front perspective views showing the carrier and lens of Figs. 7A and 7B, with Fig. 8A showing the lens prior to engagement with the carrier and Fig. 8B showing the lens partially engaged with the carrier as it is inserted;

**[0028]** Fig. 9 is an enlarged perspective from above and to the front showing the carrier and lens of Figs. 7A, 7B, 8A and 8B;

**[0029]** Figs. 10 and 11 are enlarged views of the carrier and lens shown in Figs. 7A and 7B, with Fig. 10 showing one option for lens removal and Fig. 11 showing another option for lens removal;

**[0030]** Fig. 12 is a front view of the cartridge of Fig. 1;

**[0031]** Fig. 13 is a bottom view taken from line 13-13 in Fig. 12; and

**[0032]** Fig. 14 is a section view similar to Fig. 4 and taken along the line 14-14 in Fig. 12;

**[0033]** Fig. 15 is a perspective view from the front and side of a replacement lens;

**[0034]** Fig. 16 is an enlarged perspective view from above of a portion of the lens of Fig. 15;

**[0035]** Fig. 17 is an enlarged perspective view from below of a portion of the lens of Fig. 15;

**[0036]** Fig. 18 is an enlarged perspective view from above of a portion of the cartridge of Fig. 1;

**[0037]** Fig. 19 is an enlarged perspective view from the front showing a portion of the cartridge of Fig. 19;

**[0038]** Fig. 20 is a perspective view from the front and side of the cartridge of Fig. 1;

**[0039]** Fig. 21 is a somewhat diagrammatic perspective view from the front and above of an alternate embodiment of the lens cartridge;

-6-

- [0040]** Fig. 22 is a partial section view taken along line 22-22 in Fig. 21;
- [0041]** Figs. 23A and 23B are perspective views from the front of an alternate embodiment of a respirator and lens cartridge concept as worn by a worker with additional protective garments;
- [0042]** Fig. 24 is a perspective view from the front of the alternate embodiment of the lens cartridge and lenses of Fig. 23A and 23B;
- [0043]** Fig. 25 is an exploded perspective view from the front of the respirator of Figs. 23A and 23B;
- [0044]** Fig. 26 is an exploded perspective view from the rear of the respirator of Figs. 23A and 23B;
- [0045]** Fig. 27 is an enlarged exploded rear view of selected components of the respirator of Figs. 23A and 23B;
- [0046]** Fig. 28 is a perspective view from the front and side of the respirator of Figs. 23A and 23B with a protective shield removed;
- [0047]** Fig. 29 is a perspective view similar to Fig. 28 but showing the protective shield in place;
- [0048]** Fig. 30 is an enlarged exploded view of the cartridge and lenses of Figs. 23A and 23B;
- [0049]** Fig. 31 is an assembled perspective view of the lens cartridge of Figs. 23A and 23B and Fig. 30;
- [0050]** Figs. 32A-32C are a sequence of views illustrating the mounting of the lens cartridge to the respirator of Figs. 23A and 23B; and
- [0051]** Fig. 33 is an enlarged sectional view of the lens cartridge and respirator of Figs. 23A and 23B.

#### DETAILED DESCRIPTION

- [0052]** According to one feature, a replacement lens cartridge 10 is made from molded plastic (polycarbonate, TPU, acrylic, etc.), preferably

suitable for optic purposes. Because of the process and material, the cartridge 10 offers a cost effective system compared to conventional products. Furthermore, the density of resins, such as polycarbonate, is half of the glass density which brings down the weight considerably in comparison to conventional products.

**[0053]** With reference to Figs. 1-3, the cartridge 10 is provided for use on a face mask of a respirator or other device having a permanent lens for protecting the eyes of a user, such as the face mask 12 of the respirator 14 shown in Fig. 2. The cartridge 10 comprises a carrier 20 and multiple (3 or 4) disposable lenses 22. The cartridge 10 is preferably molded and is not limited to flat surfaces. Accordingly, each lens 22 can have a curved shape and, for example, can be a cylindrical lens, a spherical lens, or a toric lens. With those curvatures it's possible to offer more peripheral view. In one embodiment, each lens 22 inside the carrier 20 is identical. However, if overwhelming distortion occurs by stacking the lenses 22, it would be possible to make each lens 22 slightly different to correct distortion made by the previous lens 22 in the cartridge 10.

**[0054]** As seen in Fig. 3, when the cartridge 10 is mounted on the respirator 14, it abuts a protective rubber 24 that covers a permanent lens 26 of the respirator 14. This will create a small gap  $g$  between the permanent lens 26 and the cartridge 10, which will allow proper assembly of the cartridge 10 on the respirator 14 even if grit is trapped between the two. As shown in Fig. 5, another way to create the gap  $g$  is by adding a glued rubber cord 30 that follows the perimeter on the back surface 32 of the cartridge carrier 20. This structure can also be achieved by co-injection as well.

**[0055]** The carrier 20 holds the stack of lenses 22 together and provides means to attach the cartridge 10 on the respirator 14. It's also the last layer of protection of the cartridge 10 with a fixed lens 33. As best seen in Figs. 6A-6G, the carrier 20 has a top tooth 34 that can be inserted into a face mask clamp or

-8-

slot 36 on the face mask 12 of the respirator 14. Aligned with this top tooth 34, there is a catch in the form of a slot 38 on the carrier 20 to receive a catch in the form of a lens top tooth 40 on the first loaded lens 22. There is hook or slot 42 on each side of the carrier 20 to secure the cartridge 10 on the respirator 12 by engagement with corresponding hook receiving tabs 44 on each side the face mask 12 of the respirator 14.

**[0056]** As best seen in Figs. 3, 7A and 7B, the carrier 20 includes a bridge 46 that extends over the nose of a wearer and has a blade or tab 48 that has a set of catches in the form of openings 50 to receive a catch in the form of a bottom tooth 52 of each of the lenses 22. This blade 48 is cantilevered from the bridge 46 and will bend when each of the lenses 22 are inserted into the carrier 10, then move to its initial or as-molded position to secure the lenses 22 in place.

**[0057]** As best seen in Figs. 8 and 9, on the perimeter of the carrier 10 there is an extrusion or peripheral lip 56 that extends forward to protect the lens 22 from dust that could enter between each of the lenses 22. This peripheral lip 56 also helps to avoid lens shifting.

**[0058]** As best seen in Figs. 1 and 6A, each lens 22 in the cartridge 10 has a transparent pull tab 58 centered on the lens 22 to overlie a nose bridge portion 59 of the lens 22 and attached to the lens 22 for removal of the used lens 22. This tab 58 could be over molded in the lens 22 or glued in a secondary operation. There is a recess 60 on the front surface 62 of the lenses 22 to receive the folded tab 58 to avoid any gaps between the lenses 22.

**[0059]** As best seen in Fig. 4, each lens 22 has a top tooth 40 and a bottom tooth 52. As previously discussed, the top tooth 40 is made to align the first lens 22 in the carrier top slot 38. There is also a top slot 64 on each lens 22 to align the next lens 22 by receiving the top tooth 40 of the next lens 22. There is a forwardly projecting extrusion or lip 68 on the upper section of the each lens 22 to avoid shifting of the lenses 22 relative to each other.

**[0060]** The bottom tooth 52 on each lens 22 will snap into the blade 48 of the carrier bridge portion 46, with each lens 22 having its own opening 50 in the blade 48. As illustrated by the horizontal dashed lines in Fig. 10, the bottom tooth 52 will break when the tab 58 is pulled. As illustrated by the vertical dashed lines in Fig. 11, another option is that a portion of the blade 48 on the bridge 46 breaks instead of the lens bottom tooth 52.

**[0061]** Figs. 21 and 22 illustrate an alternate embodiment of the cartridge 10 wherein the carrier 20 has an L-shaped cross-section with a lip 70 that extends forwardly and includes a number of tab receiving openings 72 that receive mount tabs 74 formed on each of the lenses 22. This mount structure replaces the teeth 34, 40 and 52, slots 38 and 64, openings 50, blade 48, and bridge 46 of the embodiment illustrated in Figs. 1-20. This embodiment also differs from the previously described embodiment in that the pull tab 58 is attached to and extends in cantilevered fashion from an upper portion of each lens 22, rather than from a lower central portion as in Figs. 1-20.

**[0062]** Figs. 23A-33 illustrate another embodiment for the lenses 22 and lens cartridge 10 together with a respirator 14 for that embodiment, with like reference numbers indicating similar features and/or components.

**[0063]** As with the prior described embodiments, the embodiment of Figs. 23A-33 is mostly dedicated to the shipyard industry, but could be suitable for different types of construction site where sandblasting/shot blasting is performed, and could also be extended to other industries such as welding, painting, oil rig and any other activities that require optic protection that gets damaged by different media (dirt, oil, paint, etc).

**[0064]** As with the prior described concepts, the concept is to make the replacement lens cartridge 10 with molded plastic (polycarbonate, TPU, acrylic, etc) suitable for optic purposes. Because of the process and material, this concept is also a cost effective system. Density of resins, such as

-10-

polycarbonate, is half of the glass density which brings down the weight considerably.

**[0065]** The embodiment of Figs. 23A-33 differs from the embodiment of Figs. 1-20 in that it has eliminated the cantilevered blade 48 and openings 50 on the carrier 20, the corresponding tooth 52 on each of the lenses 22, the top tooth 40 on each of the lenses 22 and the corresponding slot 64 on each of the lenses 22 and has provided for a different means of releasably securing each of the lenses 22 to the carrier 20, as will be discussed more fully below.

**[0066]** As with the prior embodiments, the cartridge 10 comprises a carrier 20 and multiple disposable lenses 22 (3 or 4). Because the cartridge 10 is molded, the lenses 22 are no longer limited by flat surfaces, and are cylindrical lens, spherical lens or toric lens. With those curvatures it's possible to offer more peripheral view.

**[0067]** While each lens inside the carrier 20 can be identical, if overwhelming distortion occurs by stacking the lenses 22 it would be possible to make each of them slightly different to correct distortion made by the previous lens 22 in the cartridge 10. More specifically, as best seen in Fig. 30, the fixed lens 33 of the carrier 20 and each of the replacement or disposable lens 22 (1, 2 and 3) has its own inside and outside spherical radius to correct distortion/deformation that was created by the previous one. Each replacement lens 22 is different in size and has different positions for a plurality of catches in the form of retaining hooks, tabs, or projections 100 formed on the perimeter of each lens 22 that clip into a corresponding set of catches in the form of recesses, openings, or grooves 110 formed into the peripheral lip 56 of the carrier 20. This will ensure that replacement lenses 22 are in the right order in the carrier 20 to provide optimal optics. The goal is to obtain almost no distortion with multiple layers of lenses 22.

**[0068]** As best seen in Figs. 32A-32C, when the lens cartridge 10 is mounted on the respirator 14, it leans on a protective rim 102 that is molded on

-11-

the base lens 26 of the face mask 12 of the respirator 14. There is rubber/TPE piece or shield 24 that covers portions of the base lens 26 and the filter of the respirator 14. As best seen in Fig. 33, between the base lens 26 and the lens 33 carrier 22 there is a gap  $g$  of air that plays a role in the optic correction. There is also a gap  $g$  of air between each lens 22 to allow geometric compensation.

**[0069]** The carrier 20 holds the stack of lenses 22 together and provides means to attach the cartridge 10 on the respirator 14. Its lens 33 is also the last layer of protection of the cartridge 10. As best seen in Figs. 32A-32C, the carrier 20 has a top tooth 34 that is inserted into a clamp or slot 36 in the rim 102 on the respirator 14. There is a catch in the form of a projection or hook 42 on each side of the carrier 20 to secure the lens cartridge 10 on the respirator 14 by snap engagement with catches in the form of indents or recesses 44 on the face mask 12. As previously discussed, each replacement lens 22 is retained by the catches 100 on its perimeter that are inserted in the corresponding carrier catches 110.

**[0070]** Each lens 22 in the cartridge 10 has a transparent or opaque pull tab 58 in the center for removal of the used lens 22. As best seen in Figs. 30 and 33, this tab 58 can be snapped in a secondary operation by inserting each tab 58 through a slot 112 in the corresponding lens 22 until a thickened end 114 of the tab 58 is received in an indent 116 on the back face of the lens 22. There is a recess 60 on the front surface of the lens 20 to receive the folded tab 58 to avoid creating any unwanted gaps between the lenses 22.

**[0071]** It will be appreciated by those skilled in the art that there are many possible modifications to be made to the specific forms of the features and components of the disclosed embodiments while keeping within the spirit of the concepts disclosed herein. Accordingly, no limitations to the specific forms of the embodiments disclosed herein should be read into the claims unless expressly recited in the claims.

-12-

## CLAIMS

1. A replaceable lens cartridge (10) for use with a face mask, the cartridge (10) comprising:

two molded lenses (22), each lens (22) sized to extend over both eyes of a wearer and having a curved shape and a plurality of catches (100);

a molded carrier (20) mounting the lenses (22) in stacked arrangement, the carrier (20) having a first set of catches (110) receiving the catches (100) on one of the lenses (22) and a second set of catches (110) receiving the catches (100) of the other of the lenses (22), the first set of catches (110) having locations on the carrier (20) that differ from locations of the second set of catches (110) on the carrier (20); and

wherein the curved shape of each of the lenses (22) differs from one lens (22) to the next to compensate for optical distortions produced by the lenses (22) mounted in stacked arrangement on the carrier (20).

2. A replaceable lens cartridge (10) for use with a face mask, the cartridge (10) comprising:

two molded lenses (22), each lens (22) sized to extend over both eyes of a wearer and having a curved shape and a plurality of catches (40,52,100);

a molded carrier (20) mounting the lenses (22) in stacked arrangement, the carrier (20) having a first set of catches (110) receiving the catches (100) on one of the lenses (22) and a second set of catches (110) receiving the catches (100) of the other of the lenses (22), the first set of catches (110) having locations on the carrier (20) that differ from locations of the second set of catches (110) on the carrier (20); and

a plurality of pull tabs (58), each tab (58) corresponding to one of the lenses (22), centered on the lens (22) to overlie a nose bridge (59) of the lens

-13-

(22) and attached to the lens (22) to allow removal of the lens (22) from the carrier (20) when the tab (58) is pulled by a wearer.

3. A replaceable lens cartridge (10) for use with a face mask, the cartridge (10) comprising:

two molded lenses (22), each lens (22) sized to extend over both eyes of a wearer and having a curved shape and a plurality of catches (40,52,100); and a molded carrier (20) mounting the lenses (22) in stacked arrangement, the carrier (20) having a first set of catches (38,50,110) receiving the catches (40,52,100) on one of the lenses (22).

4. The lens cartridge (10) of claim 3 wherein the carrier (20) has a second set of catches (110) receiving the catches (100) of the other of the lenses (22), the first set of catches (110) having locations on the carrier (20) that differ from locations of the second set of catches (110) on the carrier (20).

5. The lens cartridge (10) of claim 4 further comprising a third molded lens (22) sized to extend over both eyes of a wearer and having a curved shape and a plurality of catches (100); and wherein the carrier (20) mounts the third lens (22) in stacked relation with the other two lenses (22) and has a third set of catches (110) receiving the catches (100) of the third molded lens (22), the third set of catches (110) having locations on the carrier (20) that differ from the locations of the first and second set of catches (110) on the carrier (20).

6. The lens cartridge (10) of claim 4 wherein the plurality of catches (100) on each lens (22) are located along a perimeter of the lens (22), with the catches of each lens (22) being spaced along the perimeter from the catches ( )

of the other lens (22) with the lenses (22) mounted in stacked arrangement on the carrier (20).

7. The lens cartridge (10) of claim 6 wherein the plurality of catches (100) on each lens (22) comprises at least four projections (100) extending from the perimeter of the lens (22), and wherein the first and second set of catches (110) on the carrier (20) comprises a matching number of reliefs on the carrier (20), each relief receiving one of the projections (100).

8. The lens cartridge (10) of claim 3 wherein the curved shape of each of the lenses (22) differs from one lens (22) to the next to compensate for optical distortions produced by the lenses (22) mounted in stacked arrangement on the carrier (20).

9. The lens cartridge (10) of claim 3 further comprising a plurality of pull tabs (58), each tab (58) corresponding to one of the lenses (22), centered on the lens (22) to overlie a nose bridge (59) of the lens (22) and attached to the lens (22) to allow removal of the lens (22) from the carrier (20) when the tab (58) is pulled by a wearer.

10. The lens cartridge (10) of claim 9 wherein each of the lenses (22) includes a recess (60) underlying the pull tab (58) to receive the pull tab (58) and prevent unwanted interference between the pull tab (58) and any adjacent lens (22).

11. The lens cartridge (10) of claim 3 wherein the carrier (20) further comprises a fixed lens (33) underlying the lenses (22) mounted in stacked arrangement on the carrier (20), the fixed lens (22) having a curved shape.

12. The lens cartridge (10) of claim 3 wherein the carrier (20) further comprises a peripheral lip (56) that extends over perimeters of the lenses (22) mounted in stacked arrangement on the carrier (20).

13. The lens cartridge (10) of claim 12 wherein the first set of catches (38,50,110) is formed in the peripheral lip.

14. The lens cartridge (10) of claim 13 wherein the carrier (20) has a second set of catches (110) formed in the peripheral lip (56) and receiving the catches (100) of the other of the lenses (22), the first set of catches (110) having locations on the peripheral lip (56) that differ from locations of the second set of catches (110) on the peripheral lip (56).

15. The lens cartridge (10) of claim 3 wherein there is an air gap between each of the lenses (22).

16. The lens cartridge (10) of claim 3 wherein each lens (22) comprises one of a cylindrical lens, a spherical lens, or a toric lens.

17. The lens cartridge (10) of claim 3 wherein the carrier (20) further comprises a plurality of mount catches (34,44) for engagement with a face mask.

Fig. 1

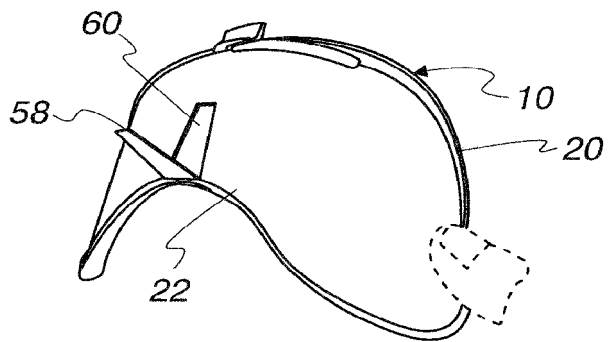
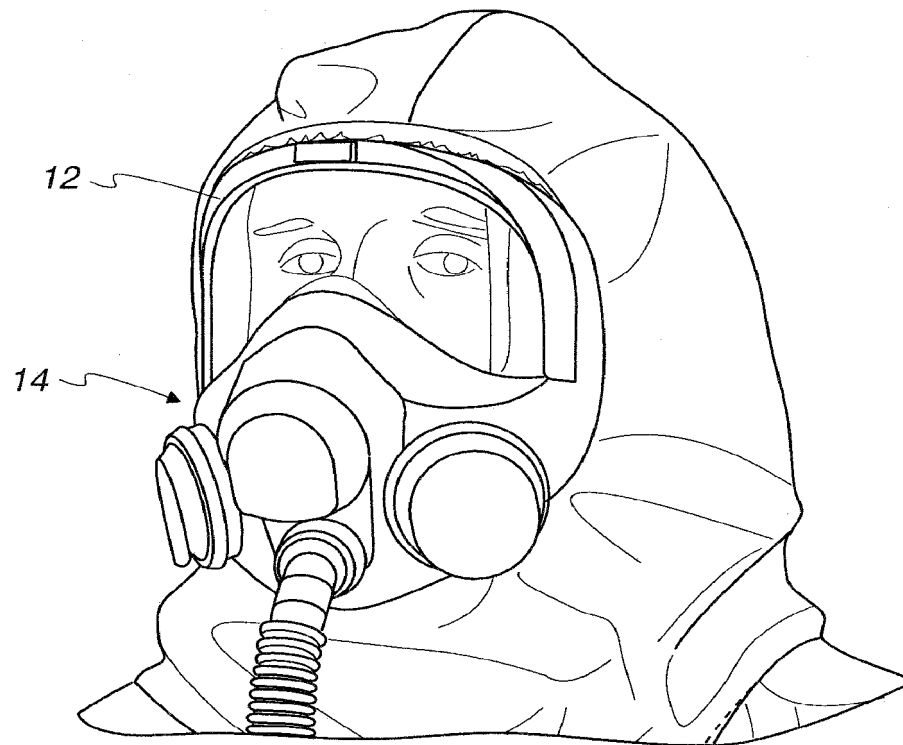

Fig. 2



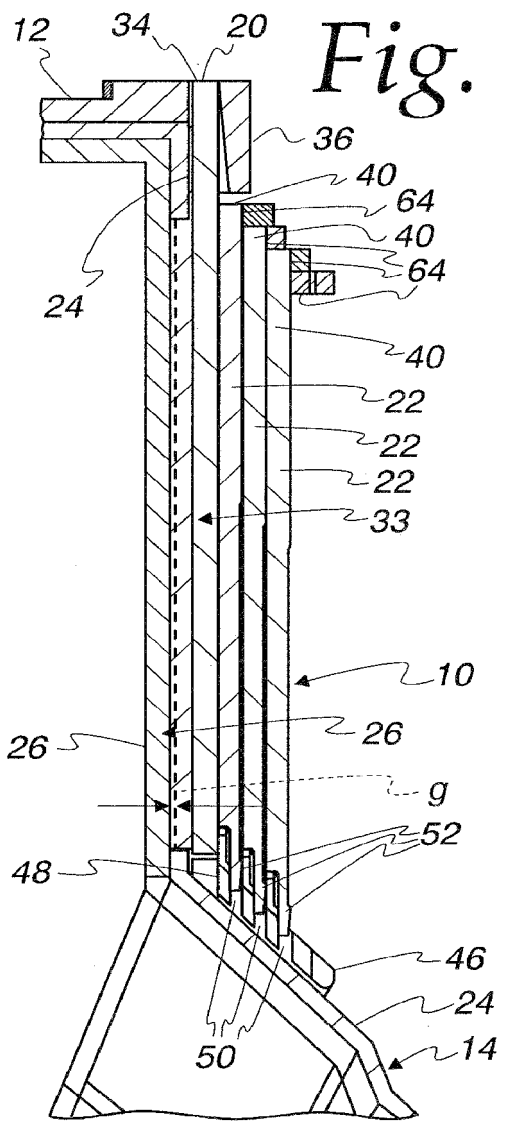

Fig. 3

Fig. 4

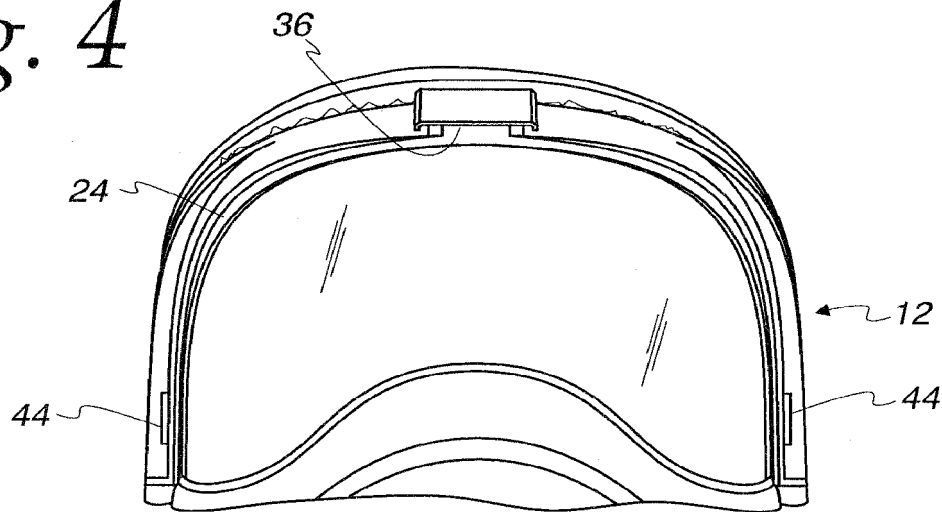

Fig. 5

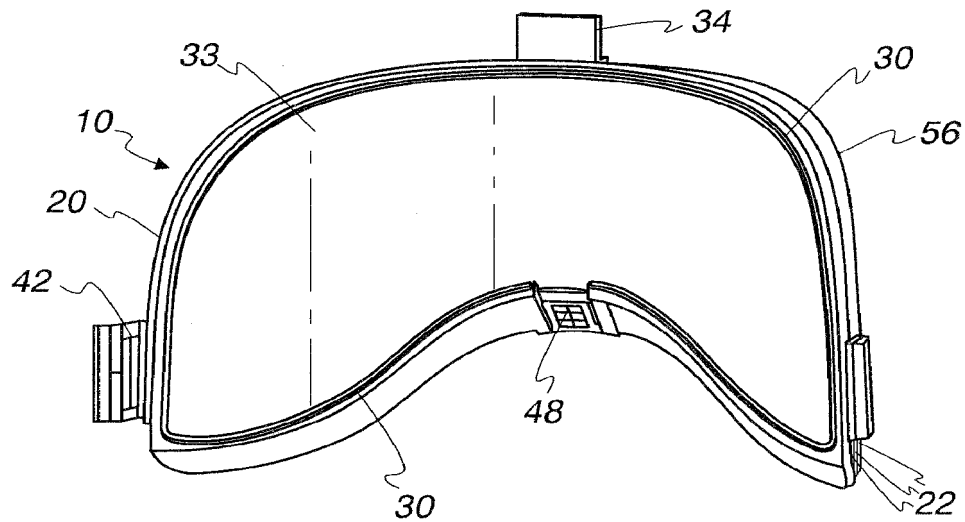

Fig. 6A

3/19

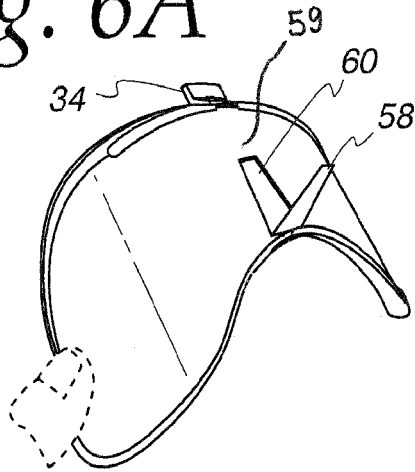

Fig. 6B

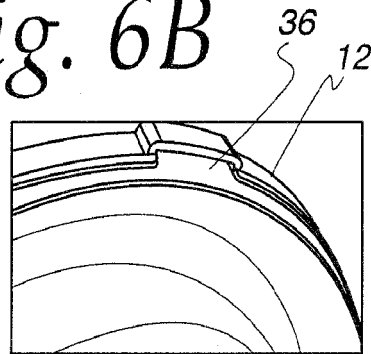

Fig. 6C

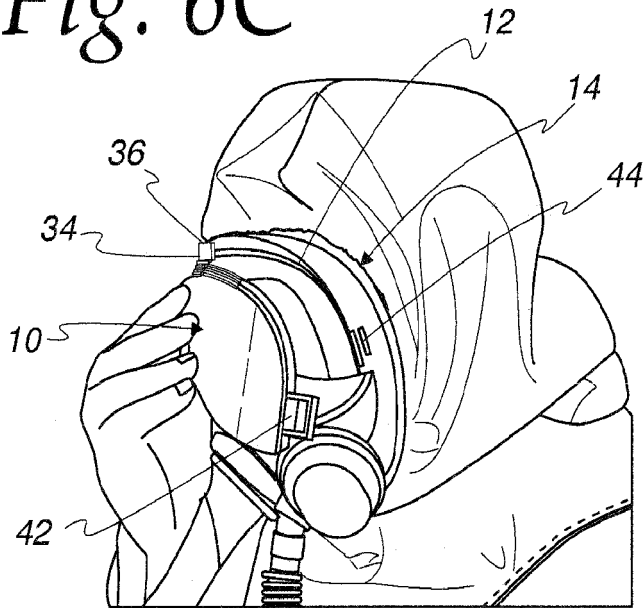
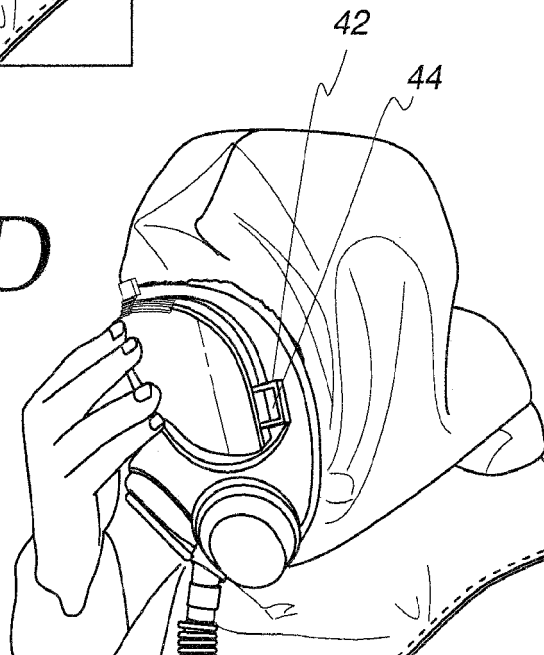
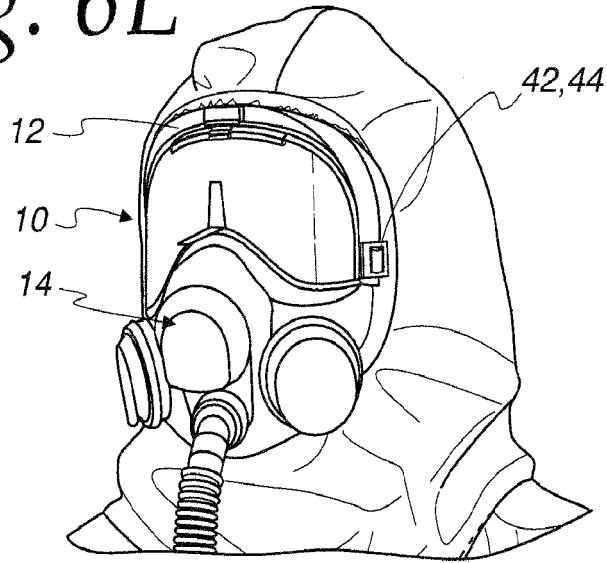

Fig. 6D



*Fig. 6E*



*Fig. 6F*

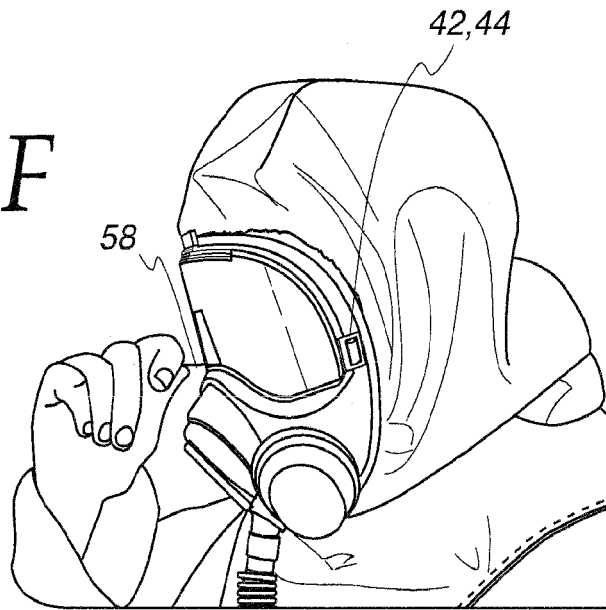

*Fig. 6G*



Fig. 7A

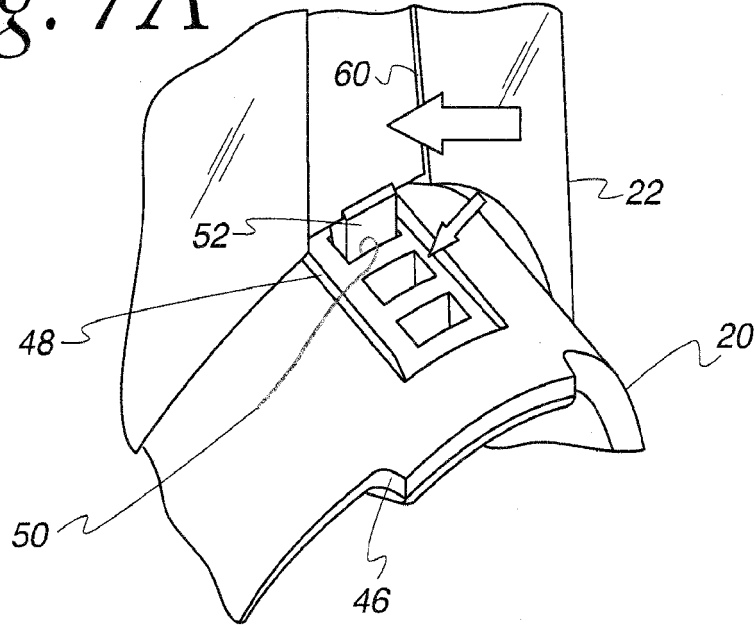

Fig. 7B

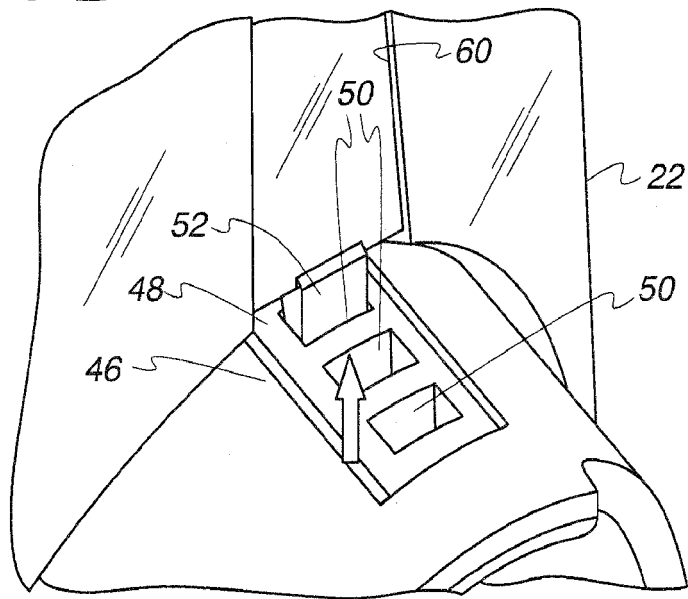

Fig. 8A

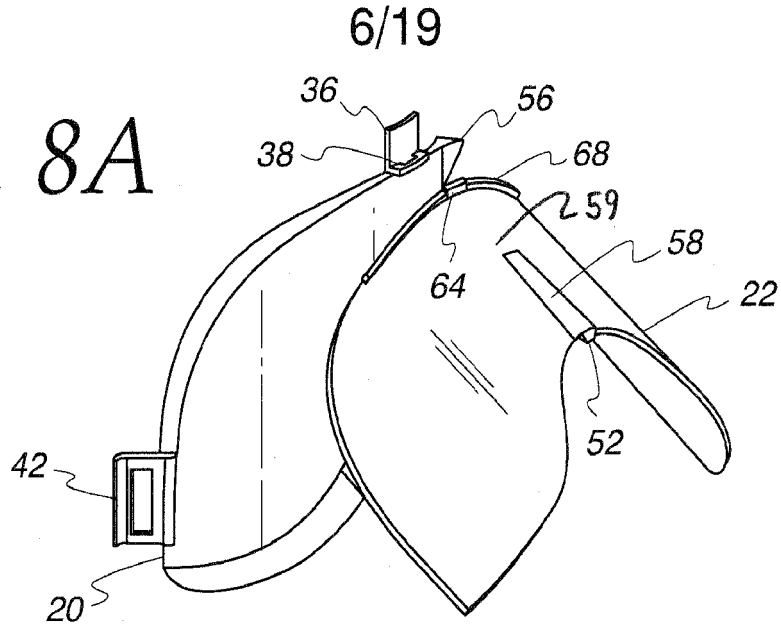

Fig. 8B

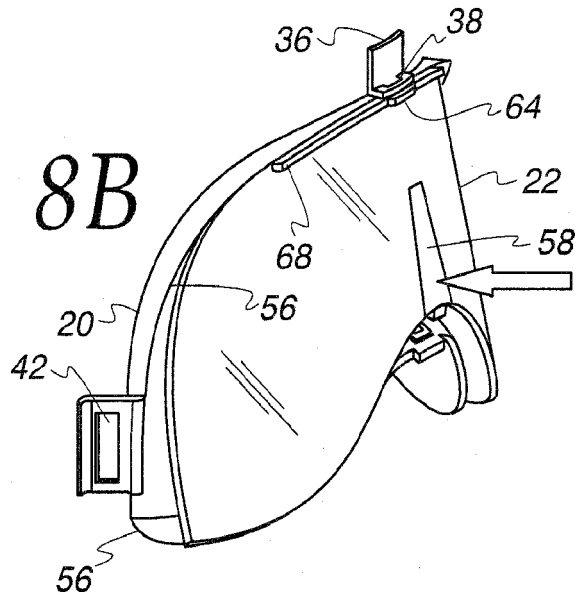
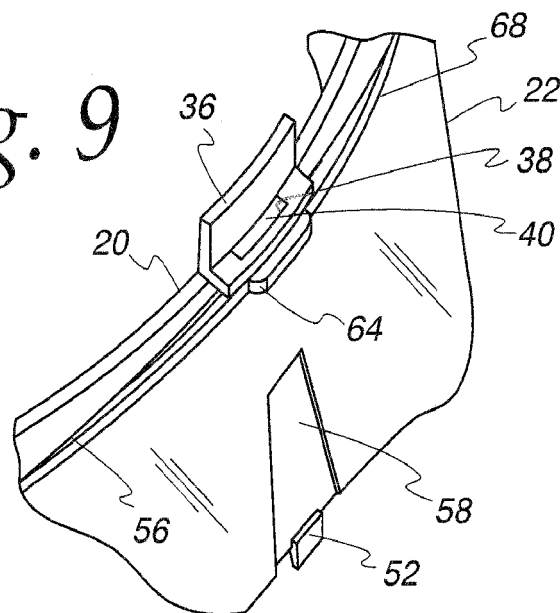

Fig. 9



7/19

Fig. 10

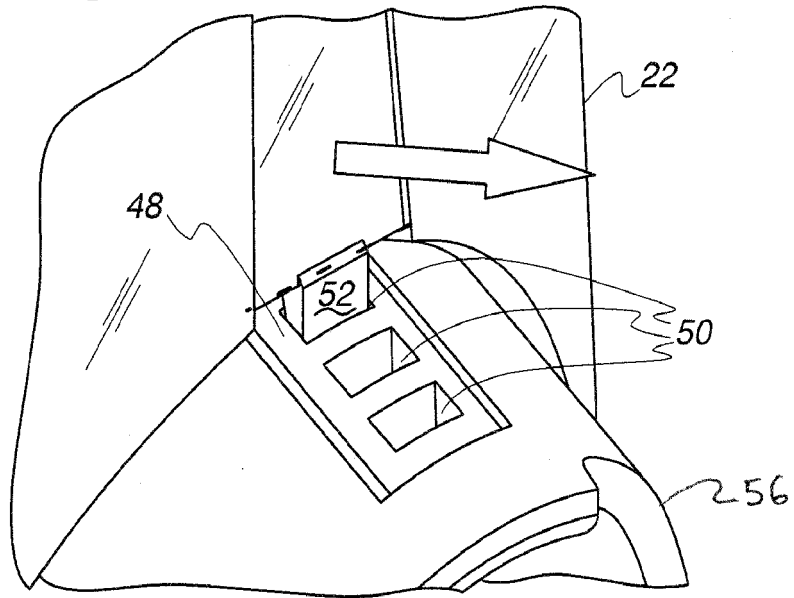

Fig. 11

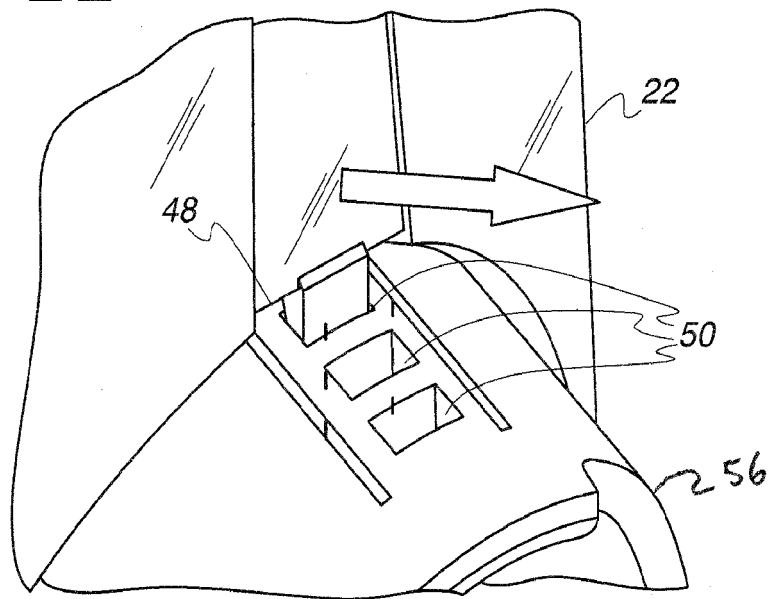

Fig. 12

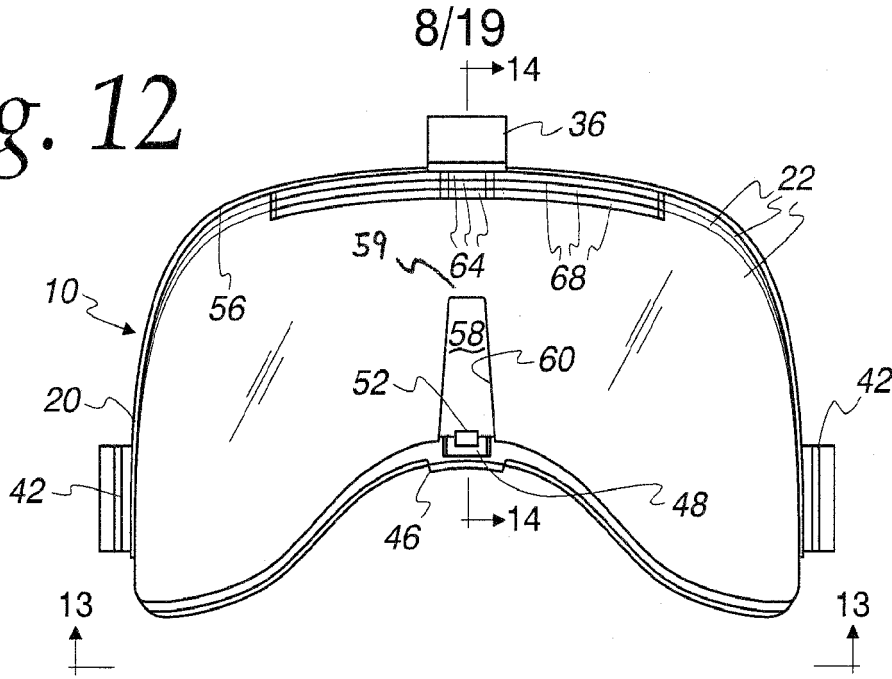

Fig. 13

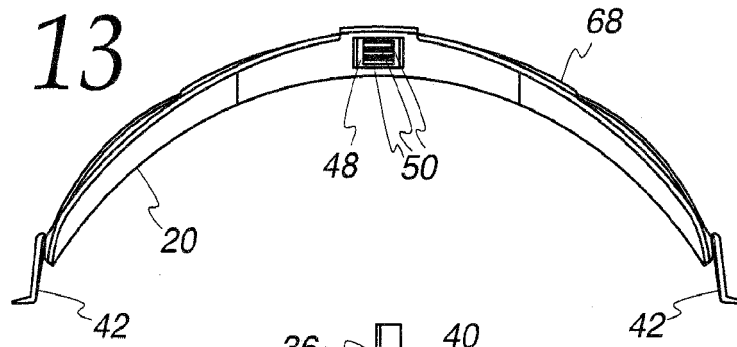
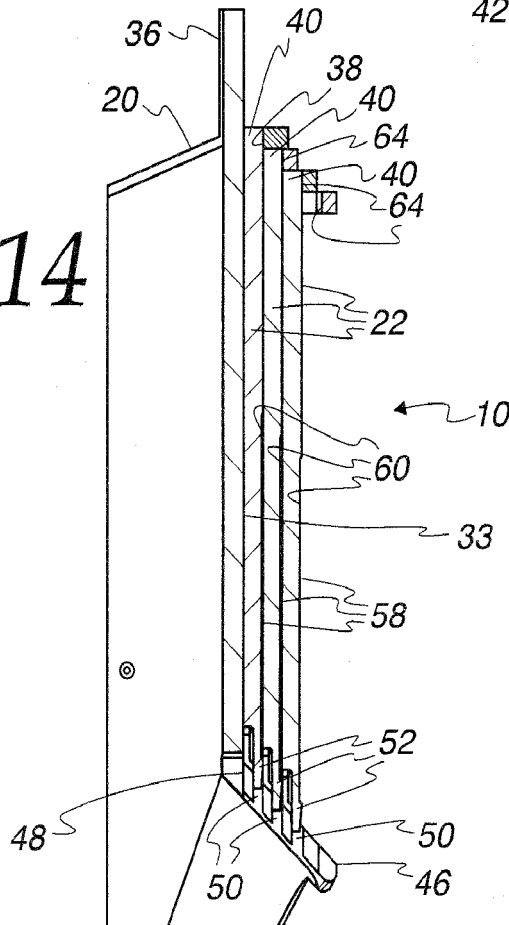
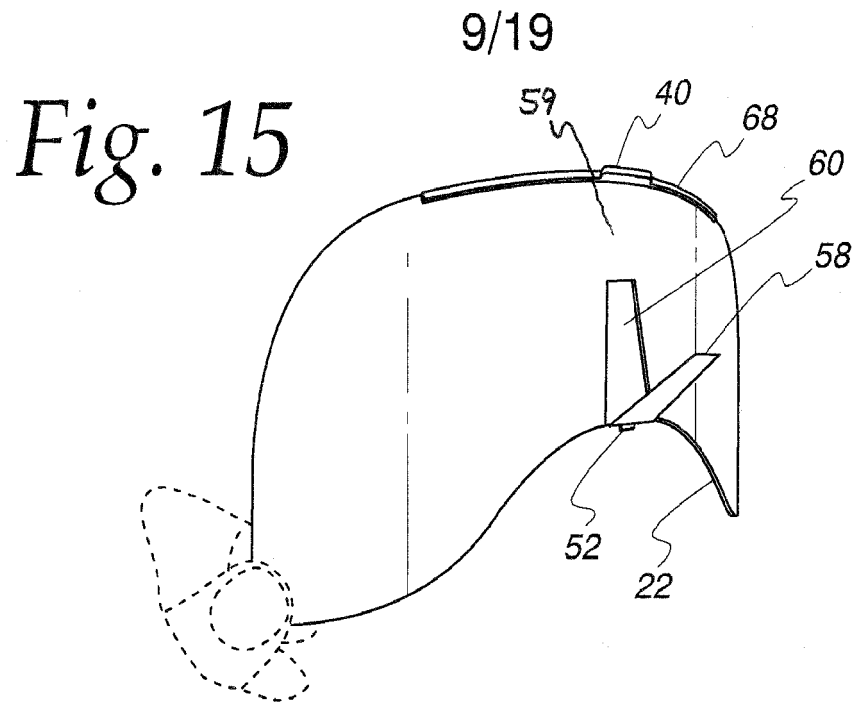
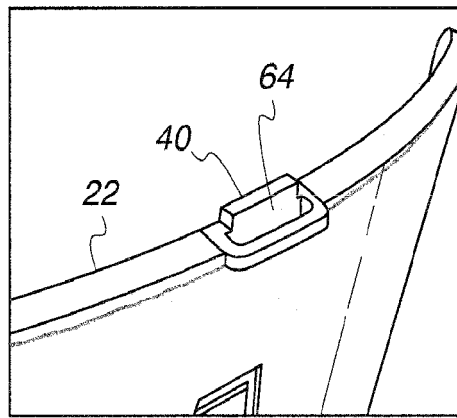

Fig. 14

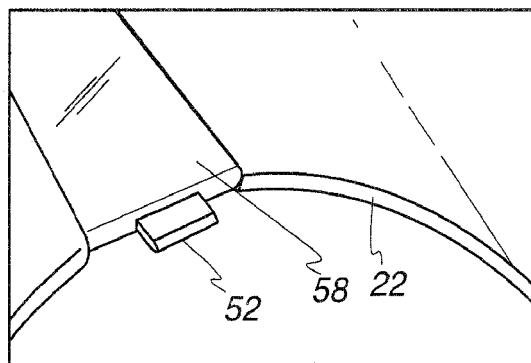



*Fig. 16*



*Fig. 17*



10/19

Fig. 18

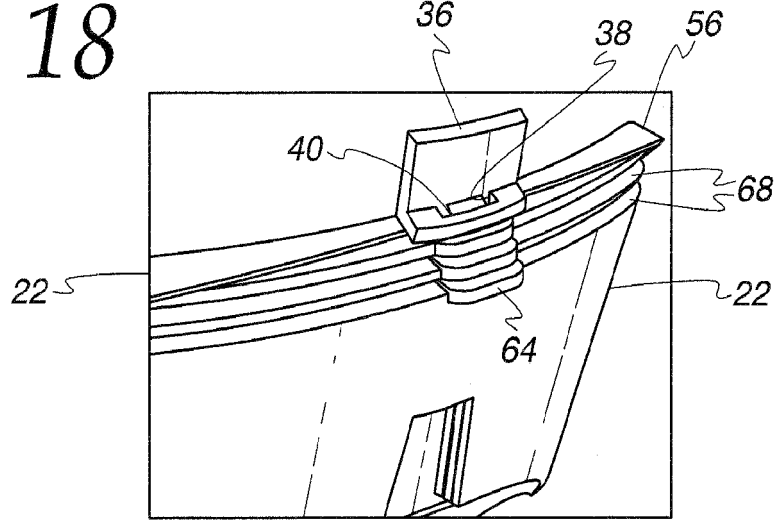

Fig. 19

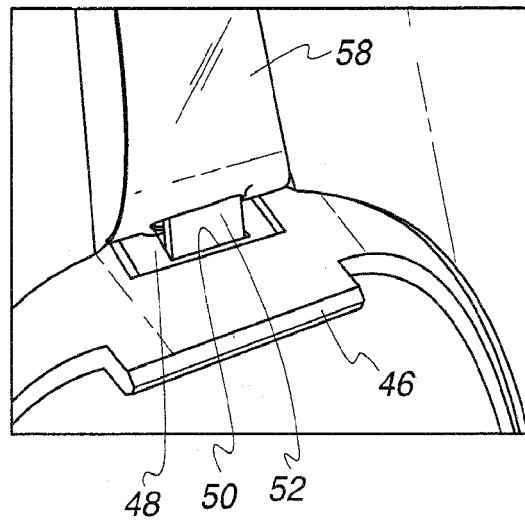

Fig. 20

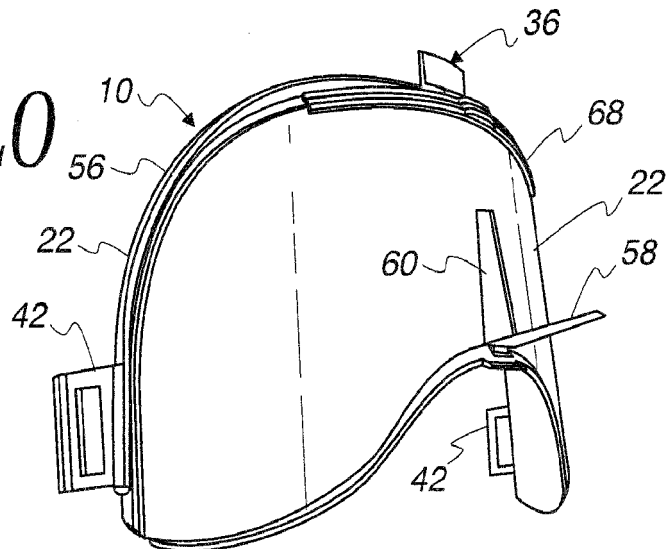

Fig. 21

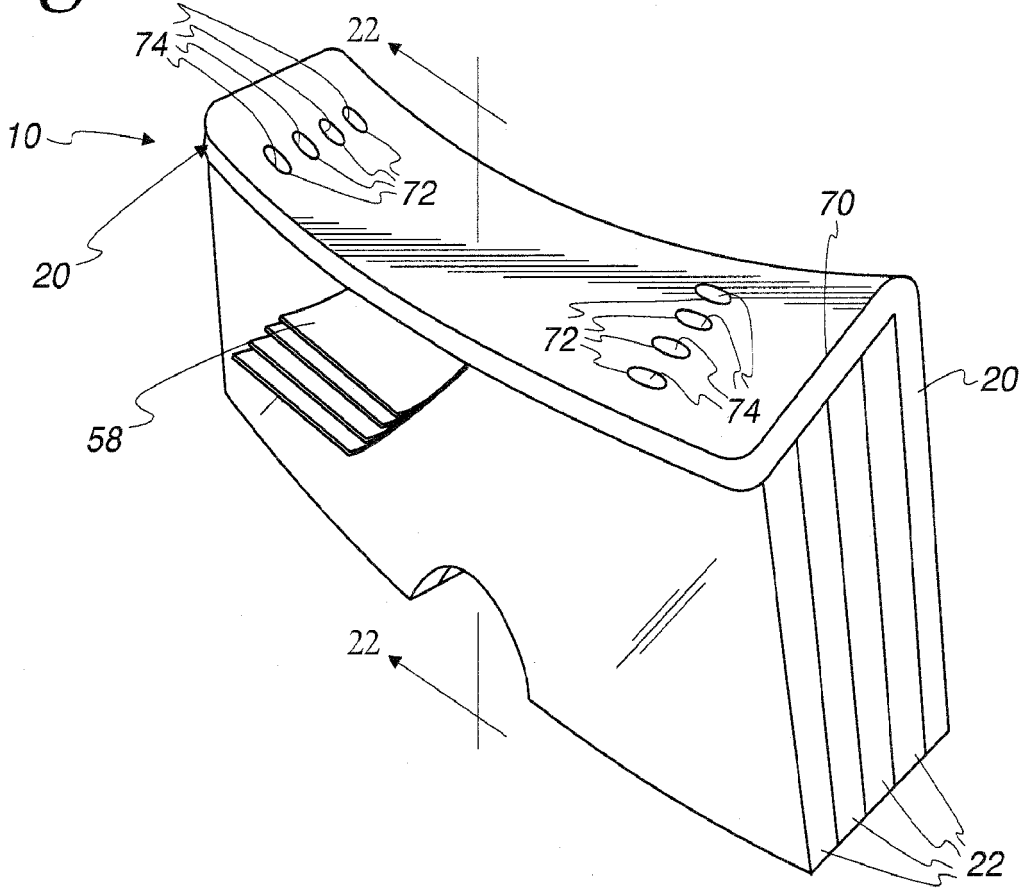
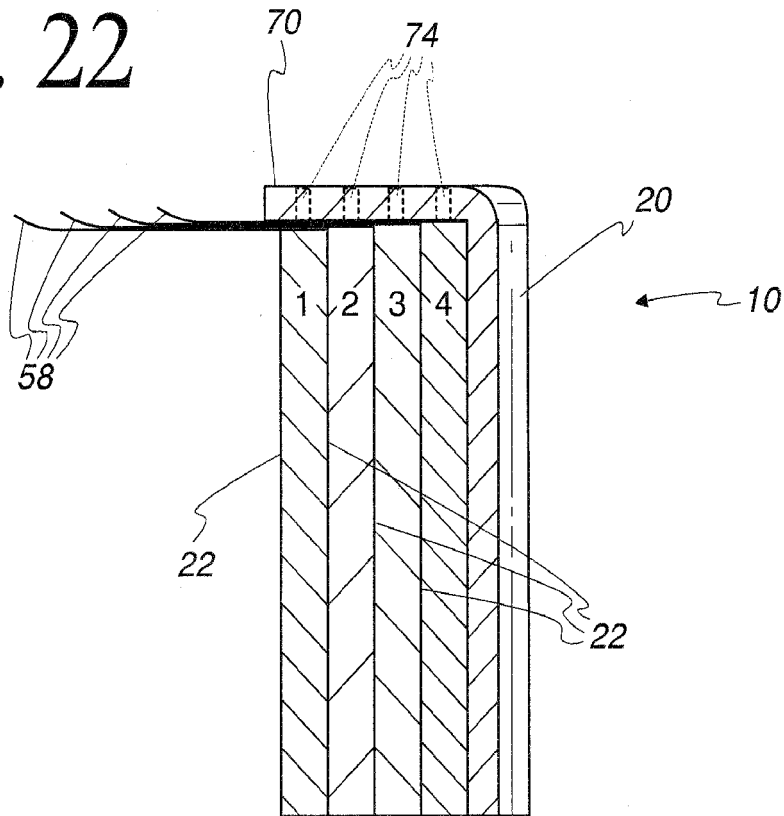

Fig. 22



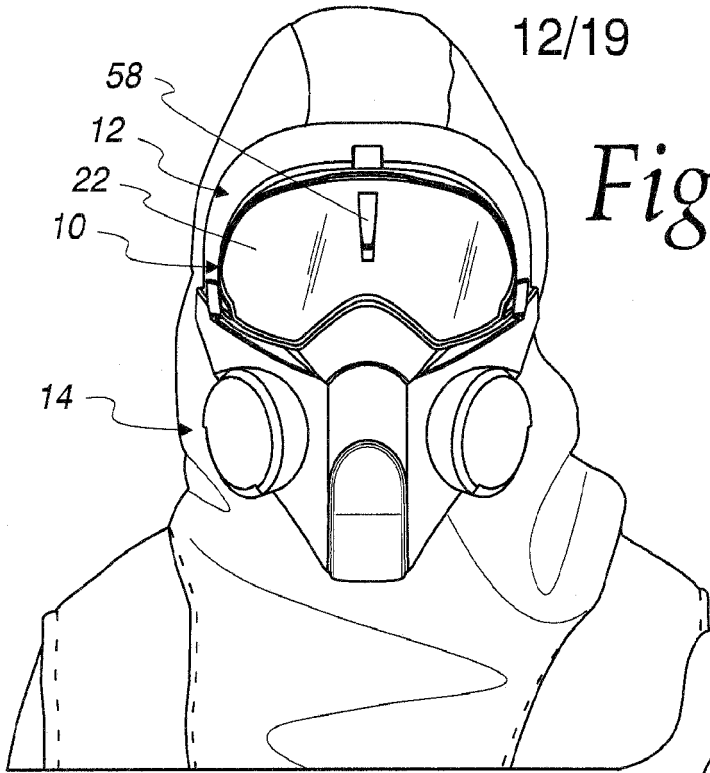

Fig. 23A

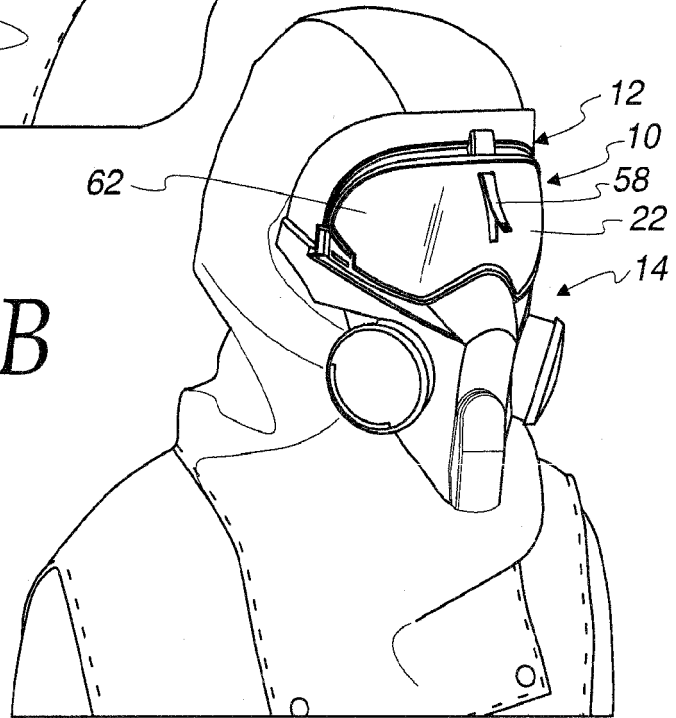

Fig. 23B

Fig. 24

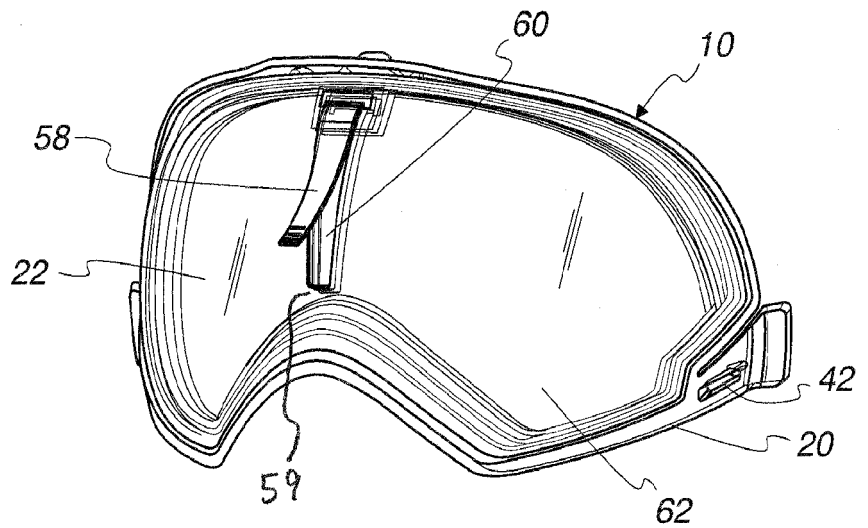
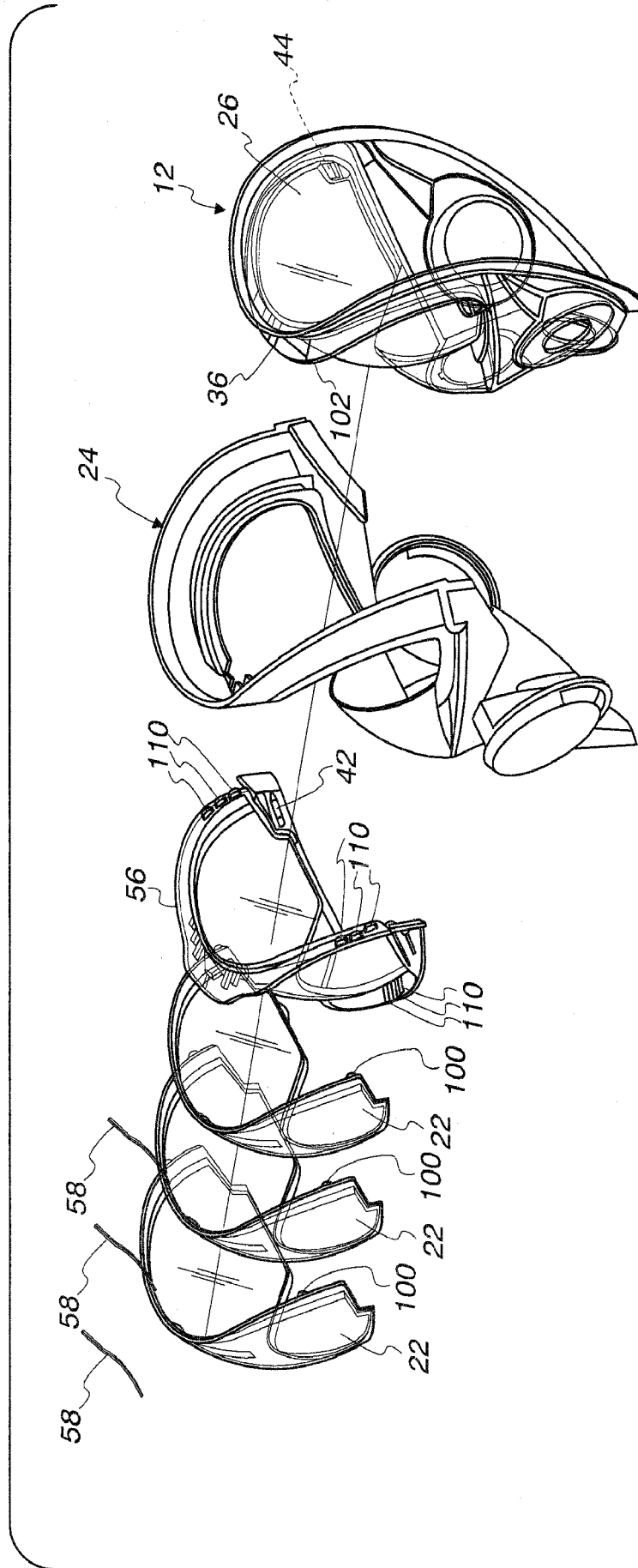
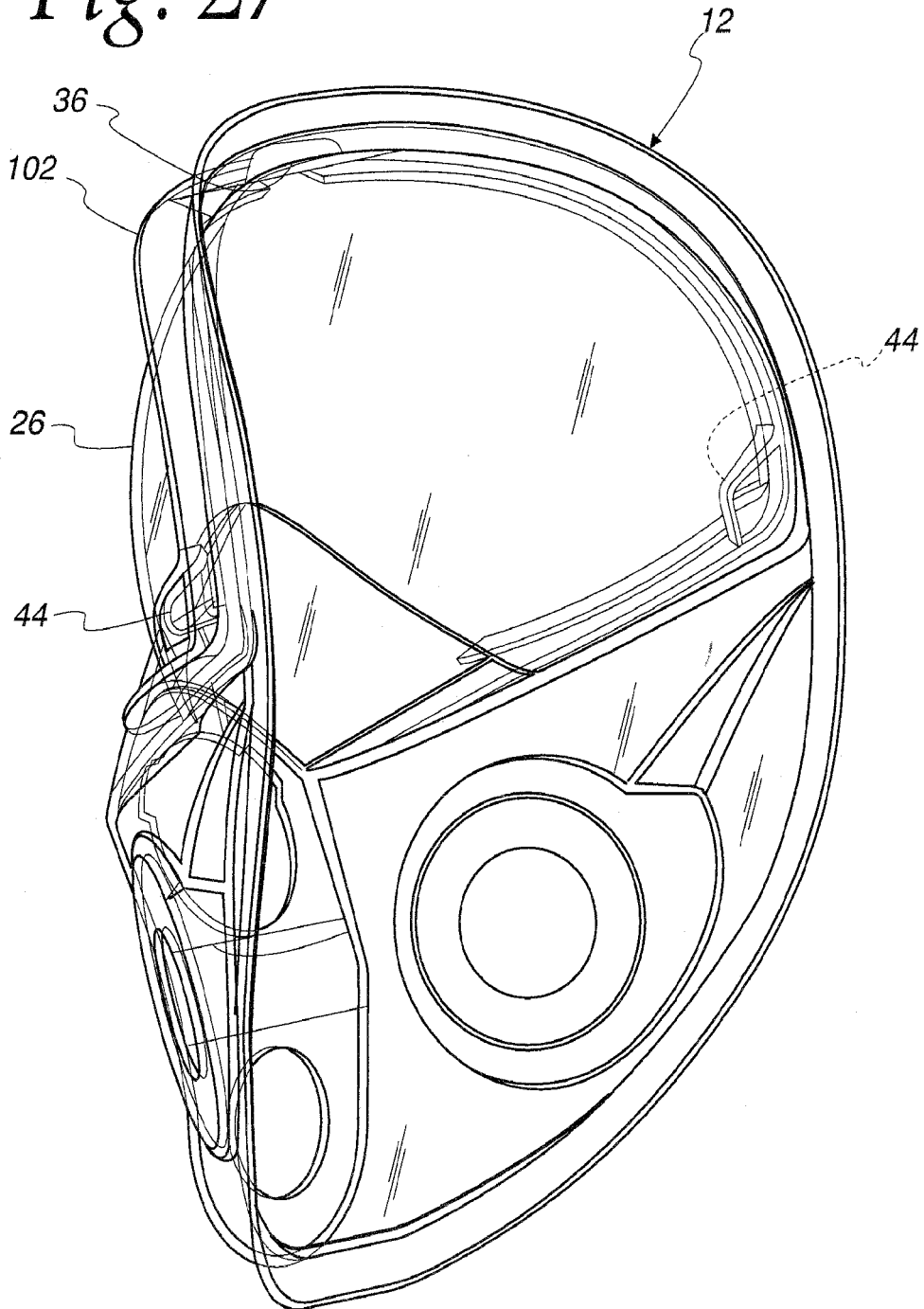



Fig. 26

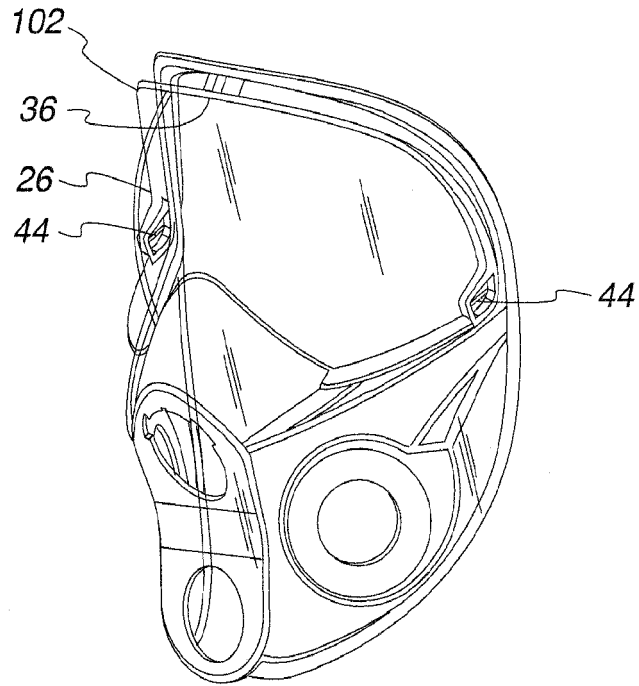

*Fig. 27*



16/19

*Fig. 28*



*Fig. 29*



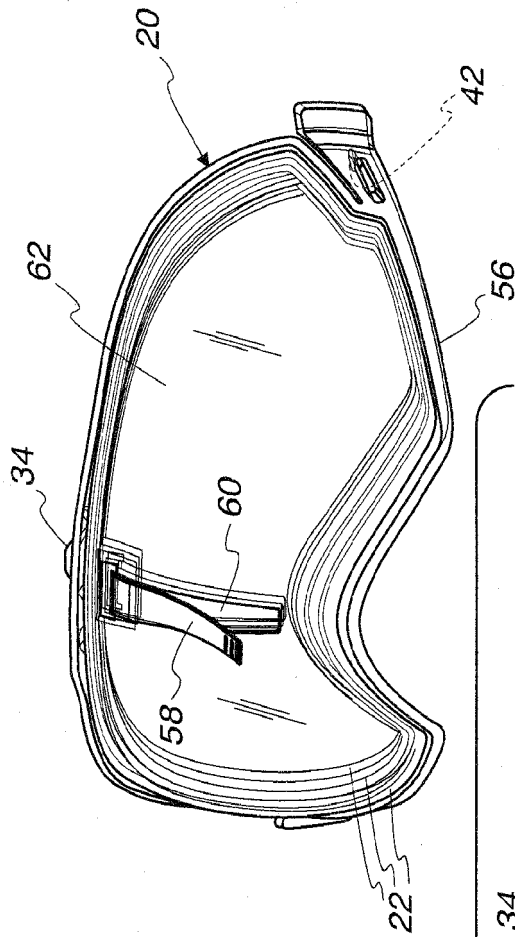

Fig. 31

Fig. 30

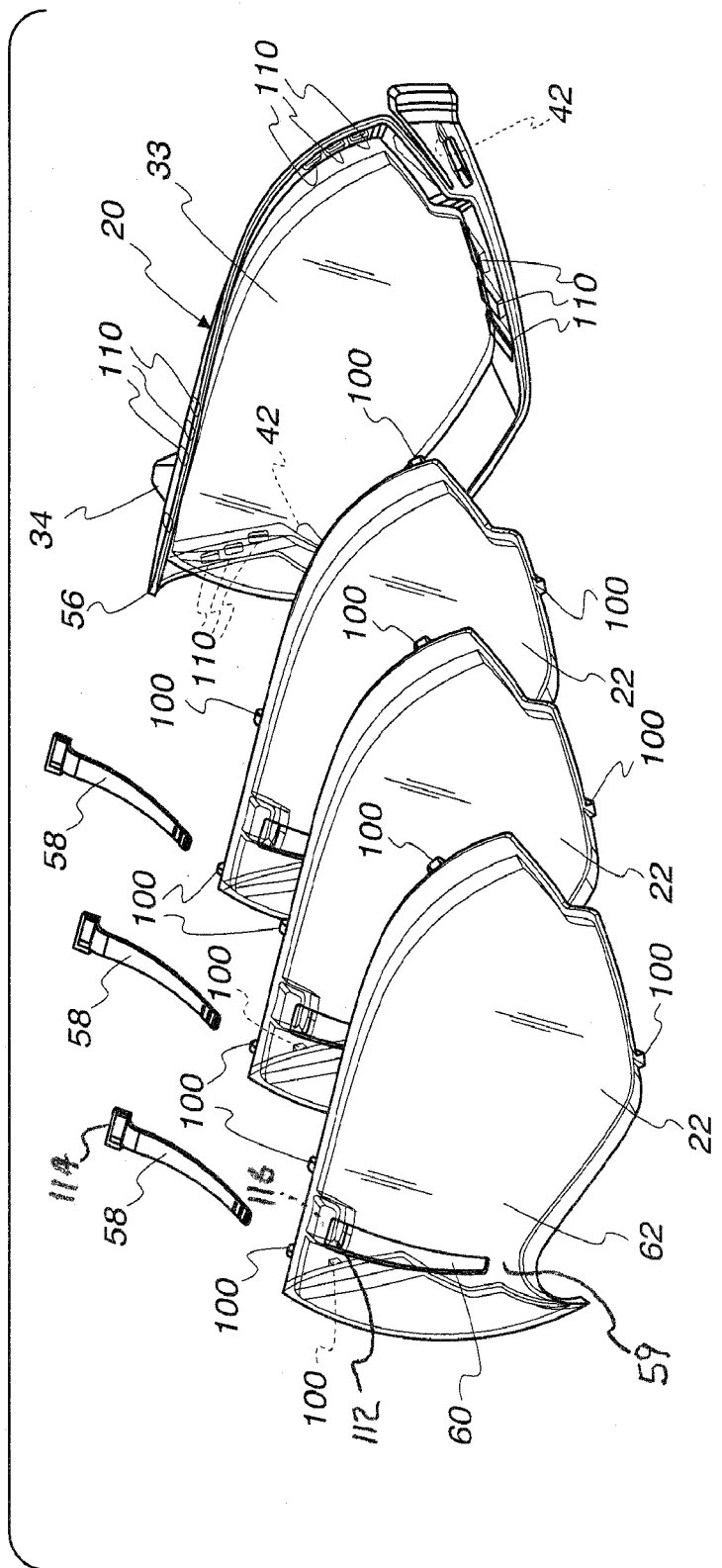

Fig. 32A

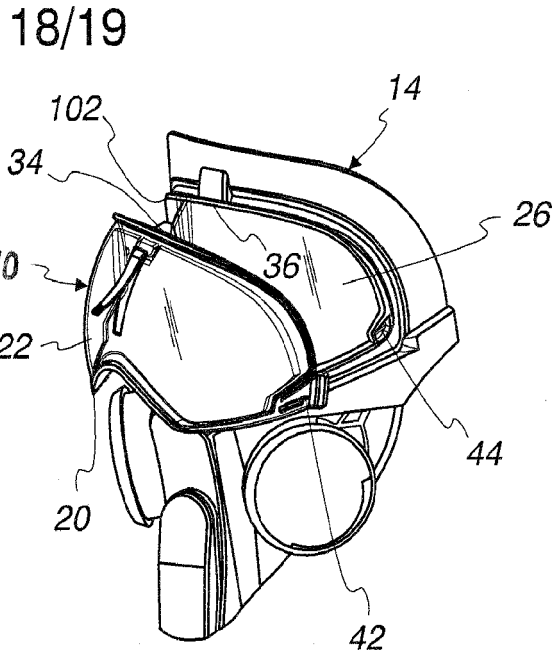

Fig. 32B

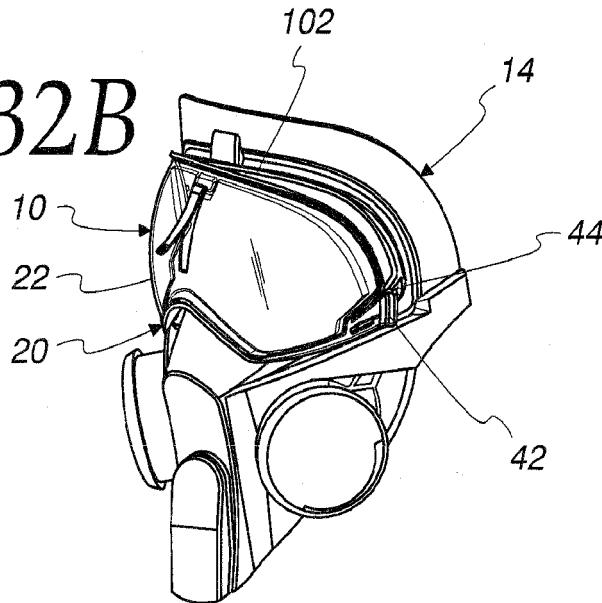

Fig. 32C

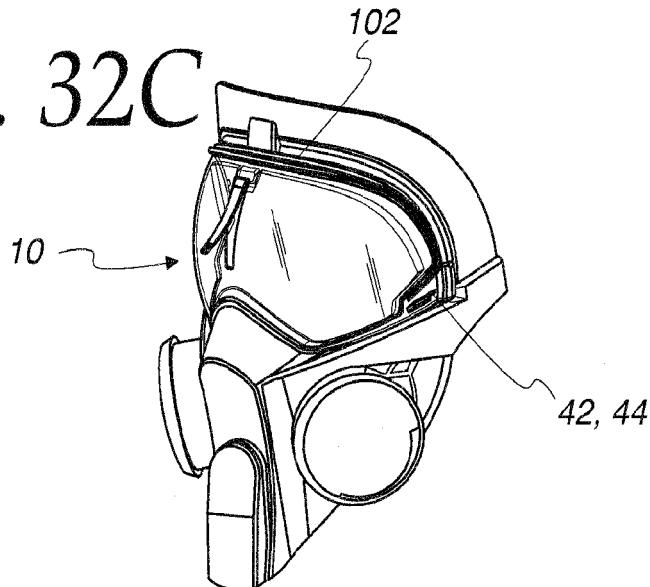

Fig. 33

