



(12) **DEMANDE DE BREVET CANADIEN  
CANADIAN PATENT APPLICATION**

(13) **A1**

(86) Date de dépôt PCT/PCT Filing Date: 2019/08/23  
(87) Date publication PCT/PCT Publication Date: 2020/02/27  
(85) Entrée phase nationale/National Entry: 2021/02/17  
(86) N° demande PCT/PCT Application No.: US 2019/047873  
(87) N° publication PCT/PCT Publication No.: 2020/041681  
(30) Priorité/Priority: 2018/08/23 (US62/722,003)

(51) Cl.Int./Int.Cl. *G06F 9/54* (2006.01),  
*H04L 12/701* (2013.01), *H04L 29/08* (2006.01)  
(71) Demandeur/Applicant:  
ARRCUS INC., US  
(72) Inventeurs/Inventors:  
SARKAR, PUSHPASHI, US;  
PATEL, KEYUR, US;  
YEUNG, DEREK MAN-KIT, US;  
PATEL, ALPESH, US;  
KREEGER, LAWRENCE ROLFE, US;  
PAI, NALINAKSH, US  
(74) Agent: ROBIC

(54) Titre : ARCHITECTURE DE MEMOIRE DE DONNEES A NœUDS MULTIPLES ET A NœUD UNIQUE DANS UN ENVIRONNEMENT DE ROUTAGE DE RESEAU  
(54) Title: SINGLE NODE AND MULTIPLE NODE DATASTORE ARCHITECTURE IN A NETWORK ROUTING ENVIRONMENT

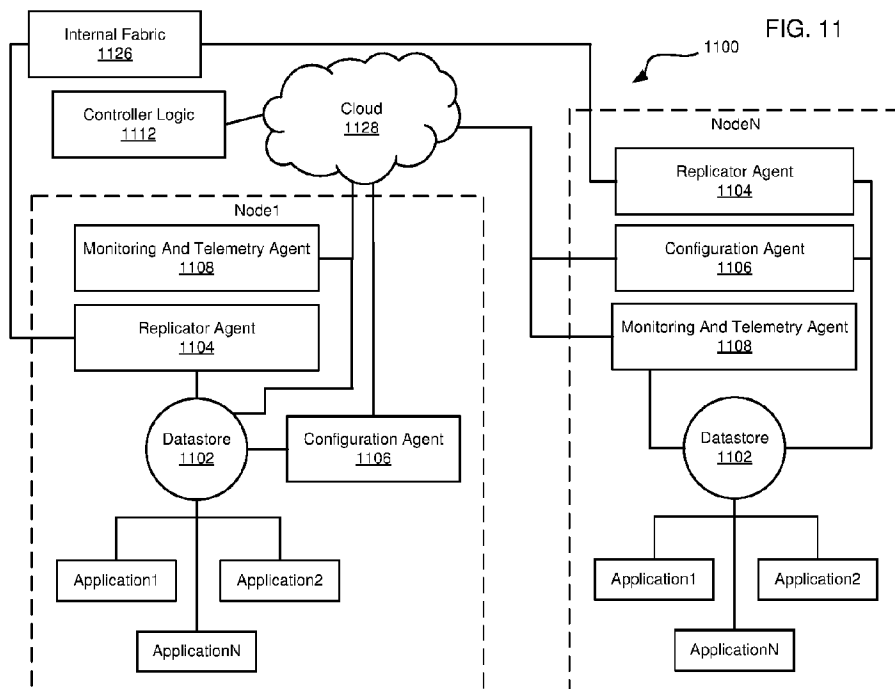

(57) **Abrégé/Abstract:**

Systems, methods, and devices for offloading network data to a datastore. A system includes a plurality of instances of a datastore node in a single networking device, each of the plurality of instances of the datastore node comprising: a datastore; a publisher independent of the datastore for publishing data to the datastore; a subscriber independent of the datastore for receiving information from the datastore; a replicator agent configured to connect to the datastore as a publisher or a subscriber; and a persistent storage agent configured to connect to the datastore as a publisher or a subscriber.

(12) INTERNATIONAL APPLICATION PUBLISHED UNDER THE PATENT COOPERATION TREATY (PCT)

(19) World Intellectual Property Organization  
International Bureau

(43) International Publication Date  
27 February 2020 (27.02.2020)



(10) International Publication Number  
**WO 2020/041681 A1**

- (51) International Patent Classification:  
G06F 9/54 (2006.01) H04L 29/08 (2006.01)  
H04L 12/701 (2013.01)
- (21) International Application Number:  
PCT/US2019/047873
- (22) International Filing Date:  
23 August 2019 (23.08.2019)
- (25) Filing Language: English
- (26) Publication Language: English
- (30) Priority Data:  
62/722,003 23 August 2018 (23.08.2018) US
- (71) Applicant: ARRCUS INC. [US/US]; 2077 Gateway Place Suite 400, San Jose, CA 95110 (US).
- (72) Inventors: SARKAR, Pushpasis; 2077 Gateway Place Suite 400, San Jose, CA 95110 (US). PATEL, Keyur; 2077 Gateway Place Suite 400, San Jose, CA 95110 (US). YE-UNG, Derek, Man-Kit; 2077 Gateway Place Suite 400,

San Jose, CA 95110 (US). PATEL, Alpesh; 2077 Gateway Place Suite 400, San Jose, CA 95110 (US). KREEGER, Lawrence, Rolfe; 2077 Gateway Place Suite 400, San Jose, CA 95110 (US). PAI, Nalinaksh; 2077 Gateway Place Suite 400, San Jose, CA 95110 (US).

(74) Agent: STEVENS, David, R.; Stevens Law Group, 1754 Technology Drive, Suite 226, San Jose, CA 95110 (US).

(81) Designated States (unless otherwise indicated, for every kind of national protection available): AE, AG, AL, AM, AO, AT, AU, AZ, BA, BB, BG, BH, BN, BR, BW, BY, BZ, CA, CH, CL, CN, CO, CR, CU, CZ, DE, DJ, DK, DM, DO, DZ, EC, EE, EG, ES, FI, GB, GD, GE, GH, GM, GT, HN, HR, HU, ID, IL, IN, IR, IS, JO, JP, KE, KG, KH, KN, KP, KR, KW, KZ, LA, LC, LK, LR, LS, LU, LY, MA, MD, ME, MG, MK, MN, MW, MX, MY, MZ, NA, NG, NI, NO, NZ, OM, PA, PE, PG, PH, PL, PT, QA, RO, RS, RU, RW, SA, SC, SD, SE, SG, SK, SL, SM, ST, SV, SY, TH, TJ, TM, TN, TR, TT, TZ, UA, UG, US, UZ, VC, VN, ZA, ZM, ZW.

(54) Title: SINGLE NODE AND MULTIPLE NODE DATASTORE ARCHITECTURE IN A NETWORK ROUTING ENVIRONMENT

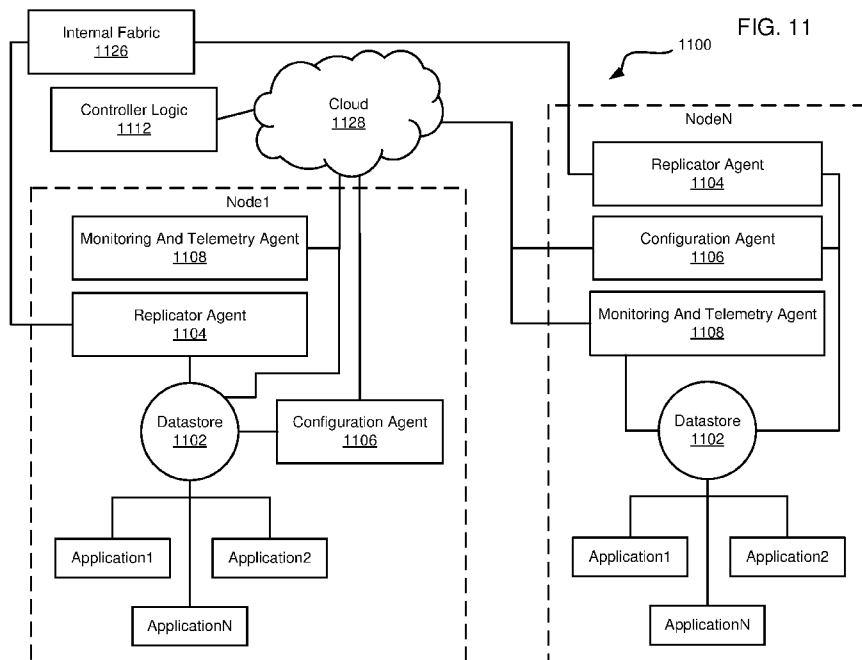

(57) Abstract: Systems, methods, and devices for offloading network data to a datastore. A system includes a plurality of instances of a datastore node in a single networking device, each of the plurality of instances of the datastore node comprising: a datastore; a publisher independent of the datastore for publishing data to the datastore; a subscriber independent of the datastore for receiving information from the datastore; a replicator agent configured to connect to the datastore as a publisher or a subscriber; and a persistent storage agent configured to connect to the datastore as a publisher or a subscriber.

WO 2020/041681 A1

**WO 2020/041681 A1** 

**(84) Designated States** (*unless otherwise indicated, for every kind of regional protection available*): ARIPO (BW, GH, GM, KE, LR, LS, MW, MZ, NA, RW, SD, SL, ST, SZ, TZ, UG, ZM, ZW), Eurasian (AM, AZ, BY, KG, KZ, RU, TJ, TM), European (AL, AT, BE, BG, CH, CY, CZ, DE, DK, EE, ES, FI, FR, GB, GR, HR, HU, IE, IS, IT, LT, LU, LV, MC, MK, MT, NL, NO, PL, PT, RO, RS, SE, SI, SK, SM, TR), OAPI (BF, BJ, CF, CG, CI, CM, GA, GN, GQ, GW, KM, ML, MR, NE, SN, TD, TG).

**Published:**

— *with international search report (Art. 21(3))*

## **SINGLE NODE AND MULTIPLE NODE DATASTORE ARCHITECTURE IN A NETWORK ROUTING ENVIRONMENT**

### **CROSS-REFERENCE TO RELATED APPLICATIONS**

[0001] This application claims priority to U.S. Provisional Patent Application Serial No. 62/722,003 filed August 23, 2018 titled “DATABASE SYSTEMS METHODS AND DEVICES,” which is incorporated herein by reference in its entirety, including but not limited to those portions that specifically appear hereinafter, the incorporation by reference being made with the following exception: In the event that any portion of the above-referenced application is inconsistent with this application, this application supersedes the above-referenced application.

### **TECHNICAL FIELD**

[0002] The disclosure relates to computing networks and particularly relates to data storage for network routing applications.

### **BACKGROUND**

[0003] Network computing is a means for multiple computers or nodes to work together and communicate with one another over a network. There exist wide area networks (WAN) and local area networks (LAN). Both wide and local area networks allow for interconnectivity between computers. Local area networks are commonly used for smaller, more localized networks that may be used in a home, business, school, and so forth. Wide area networks cover larger areas such as cities and can even allow computers in different nations to connect. Local area networks are typically faster and more secure than wide area networks, but wide area networks enable

widespread connectivity. Local area networks are typically owned, controlled, and managed in-house by the organization where they are deployed, while wide area networks typically require two or more constituent local area networks to be connected over the public Internet or by way of a private connection established by a telecommunications provider.

[0004] Local and wide area networks enable computers to be connected to one another and transfer data and other information. For both local and wide area networks, there must be a means to determine a path by which data is passed from one compute instance to another compute instance. This is referred to as routing. Routing is the process of selecting a path for traffic in a network or between or across multiple networks. The routing process usually directs forwarding on the basis of routing tables which maintain a record of the routes to various network destinations. Routing tables may be specified by an administrator, learned by observing network traffic, or built with the assistance of routing protocols.

[0005] Small networks may use manually configured routing tables to determine how information should travel from one computer to another computer. A routing table may include a listing of “best paths” indicating the most efficient or most desirable paths between a starting computer and a final destination computer. Larger networks, including networks connected to the public Internet, may rely on complex topologies that can change rapidly such that the manual construction of routing tables is unfeasible. Dynamic routing attempts to solve this problem by constructing routing tables automatically based on information carried by routing protocols. Dynamic routing enables a network to act nearly autonomously in avoiding network failures and blockages. There exist multiple routing protocols that provide rules or instructions for determining best paths between networked device. Examples of dynamic routing protocols and algorithms

include Routing Information Protocol (RIP), Open Shortest Path First (OSPF), Enhanced Interior Gateway routing Protocol (EIGRP), and Border Gateway Protocol (BGP).

[0006] In some instances, path selection involves applying a routing metric to multiple routes to select or predict the best route. Most routing algorithms use only one network path at a time. Multiple path routing techniques enable the use of multiple alternative paths. In computer networks, a routing algorithm may be used to predict the best path between two compute instances. The routing algorithm may be based on multiple factors such as bandwidth, network delay, hop count, path cost, load, maximum transfer unit, reliability, and communication cost. The routing table stores a listing of the best paths. A topological database may store a list of the best paths and may further store additional information.

[0007] In some networks, routing is complicated by the fact that no single entity is responsible for selecting best paths. Instead, multiple entities are involved in selecting best paths or event portions of a single path. In the context of computer networking over the Internet, the Internet is partitioned into autonomous systems (AS) such as Internet Service Providers (ISPs). Each autonomous system controls routes involving its network. Autonomous system-level paths are selected based on the Border Gateway Protocol (BGP). Each autonomous system-level path includes a sequence of autonomous systems through which packets of information flow to travel from one compute instance to another compute instance. Each autonomous system may have multiple paths from which to choose that are offered by neighboring autonomous systems.

[0008] In traditional network computing environments, best path determinations and other data are published by a publishing device to a plurality of subscriber devices. However, this can be computationally expensive for the publishing device. Additionally, this system provides few

safeguards against system crashes and system failures. It is therefore desirable to improve the storage of networking information.

[0009] In light of the foregoing, disclosed herein are systems, methods, and devices for offloading network data to an independent datastore.

**BRIEF DESCRIPTION OF THE DRAWINGS**

[0011] Non-limiting and non-exhaustive implementations of the disclosure are described with reference to the following figures, wherein like reference numerals refer to like parts throughout the various views unless otherwise specified. Advantages of the disclosure will become better understood with regard to the following description and accompanying drawings where:

[0012] FIG. 1 is a schematic diagram of a system of networked devices communicating over the Internet;

[0013] FIG. 2 is a schematic diagram illustrating how data is stored hierarchically in a datastore;

[0014] FIG. 3 is a schematic diagram illustrating how networking information from various applications on a single device can be offloaded and stored in a datastore;

[0015] FIG. 4 is a schematic diagram illustrating how networking information on a network device is stored in a datastore implemented locally on the same device;

[0016] FIG. 5 is a schematic diagram illustrating how storage of networking information can be offloaded to a datastore implemented elsewhere on a remote device;

[0017] FIG. 6 is a schematic diagram of communications between producers, producer consumers, and consumes with a datastore;

[0018] FIG. 7 is a schematic diagram illustrating how a datastore is implemented across multiple nodes of a single networking device;

[0019] FIG. 8 is a schematic diagram illustrating multiple devices being controlled by a remote controller offloaded to a cloud computing network;

[0020] FIG. 9 is a schematic diagram of an embodiment of a cloud-based datastore;

[0021] FIG. 10 is a schematic diagram of a system for offloading controller logic for a device to a cloud network;

[0022] FIG. 11 is a schematic diagram of a system for offloading controller logic for a multiple node device to a cloud-based controller;

[0023] FIG. 12 is a schematic diagram of an inter-process communication (IPC) based datastore;

[0024] FIG. 13 is a schematic diagram of an index server of a datastore;

[0025] FIG. 14 is a schematic diagram of a host server of a datastore;

[0026] FIG. 15 is a schematic diagram of a process flow for publishing data to a datastore and providing published data to subscriber devices;

[0027] FIG. 16 is a schematic diagram of a storage structure for data stored within a datastore;

[0028] FIG. 17 is a schematic flow chart diagram of a method for receiving and publishing data by a datastore;

[0029] FIG. 18 is a schematic flow chart diagram of a method for managing a multiple node datastore; and

[0030] FIG. 19 is a schematic diagram illustrating components of an example computing device.

**DETAILED DESCRIPTION**

[0032] Disclosed herein are systems, methods, and devices for single node and multiple node datastore architectures to be deployed in a network routing environment. In some instances of network routing, it is desirable to store routing information in a datastore that can quickly publish information to a multitude of locations at once. Disclosed herein are systems, methods, and devices for providing a datastore for storing network and routing information that is parallel to a box such as a router or a switch. In an embodiment, network states are offloaded to the datastore rather than being stored locally within the box.

[0033] In an embodiment, a datastore is a single database that is served by a single publish-subscribe (PUBSUB) entity. The datastore may be implemented and stored on multiple computing nodes. Each computing node may serve as a processing entity with its own independent computing processing entity and resources. Multiple nodes may interwork and act as a single computing entity or device (*e.g.* network devices with multiple line cards). Multiple nodes in a single computing device may still implement a single datastore but may run individual copies of datastore components on each node and interwork within themselves to make the datastore look like a datastore to any client running on any of the multiple compute nodes.

[0034] Embodiments of the disclosure include single node and multiple node database architectures. The datastore architectures can be deployed in a networking device of a network routing environment. In an embodiment, a single node datastore architecture is used in the networking device. The single node datastore architecture includes one instance of a datastore node. In the single node datastore architecture, one or more separate servers may be implemented to provide data flows between a producer and a consumer, and to host the distributed datastore. The entire single node database may be partitioned in independent datasets. A hosting server

process may be dedicated to one or more of the independent datasets. In an embodiment, a single database indexing server is deployed to maintain mapping of hosting servers and corresponding datasets hosted by each of hosting servers.

[0035] In an alternative embodiment, a multiple node datastore architecture can be deployed in a networking device of a network routing environment. The multiple node datastore architecture includes multiple instances of a datastore node. In an embodiment, the multiple node datastore architecture includes all nodes of the network device that may be implemented to maintain mapping of datasets and corresponding lists of producers and consumers across all datastore nodes of the database. Consumers may connect to the database index server by way of a datastore client to register and subscribe interest in certain datasets. Producers may connect to the database index server by way of a datastore client to update the database index to notify new and subsequently change or delete in a particular dataset. The database index server may allocate an appropriate database host server for storing the particular dataset and notify the producer. The producer may further connect to a specific host server to publish additions, modifications, and/or deletions of data objects. That database index server may notify consumers about the additions, modifications, and or deletions. In an embodiment, the database index server can connect to a specific producer to download an appropriate data changeset generated by the producer.

[0036] Datastores and databases are both used for storing information. However, there are some differences between the two types of storage architectures. A datastore can store both structured and unstructured data while a database typically stores only structured data. For example, a datastore can store structured data such as tables and can further store unstructured data such as images, videos, emails, various document formats, and so forth. A database stores structured data that is typically organized in a table format with many cells organized in rows and

columns. Databases are typically managed by a database management system (DBMS) that is configured to analyze and query the information in the database. An embodiment of the datastore discussed herein uses a single node database or a multiple node database for storing information. An embodiment of the datastore includes a database index server and a database host server 310 for performing queries and updates to the database data.

[0037] As discussed herein, a single node datastore architecture includes a single node that includes a datastore. A multiple node datastore architecture includes multiple nodes that each implement individual copies of various datastore servers that inter-work with each other to implement a single datastore across all the nodes in the network device. The multiple copies of datastore servers running on all the nodes within a multiple node datastore architecture can communicate with each other such that data produced on a node can be made available to consumer applications running on another node from a local database host server without having to fetch it every time from a database server running on the node where the producer application is running and the corresponding data would have been stored originally. This promotes faster data transfer. Multiple compute nodes in a single device may implement separate instances of the datastore but may each deploy a set of datastore servers that interact among themselves to make it appear as if the device has a single datastore. When the producer is on the same node as the consumer, the data from the producer is directly passed to the consumer without first sending the data to any other compute node.

[0038] Embodiments of the disclosure may be deployed for storing network routing information in a networking device comprising a single node datastore architecture or a multiple node datastore architecture. The single node datastore architecture includes a single datastore. The multiple node datastore architecture includes multiple datastores across multiple nodes. The

datastore provides flexibility to host data remotely rather than locally on a networking device such as a router or switch. In an embodiment, the datastore is configured for storing one or more routing tables for networked devices. The datastore can provide processing and storage resources for running applications outside the networking device. The datastore provides an ability to scale vertically and horizontally for adding storage and processing resources in a network routing environment. In an embodiment, the datastore hosts data outside the networking device and is configured to partition the data into a plurality of partitions. The partitions can be hosted on multiple storage devices that may be in communication with one another.

[0039] In an embodiment, the datastore is accessible by multiple networking devices such as routers and switches. As discussed herein, a networking device may be referred to as a BGP instance if the network device runs or stores paths determined by the Border Gateway Protocol (BGP). The BGP is used for determining a best path for transmitting data from a starting point to a destination point. In an embodiment, each of the networking devices can read information in the datastore to identify a best path for transmitting data so the data reaches its final destination. In an embodiment, each of the networking devices stores its own state at runtime and transmits its state to be replicated in the datastore. The datastore may be connected to multiple networking devices and store all states for each of the multiple networking devices. The states for each of the networking devices can thereby be offloaded to the datastore in any suitable format. In an embodiment, the datastore receives state information from multiple networking devices in real-time at runtime. The datastore may further be configured to receive snapshots of stored state information from multiple networking devices.

[0040] In an embodiment, the datastore is organized with a user-defined storage structure. The storage structure may include a hierarchy and organization defined with a JSON (JavaScript

Object Notation) based schema. The datastore may support a wide range of data structure types and support new data structure types when the need arises.

[0041] In an embodiment, the datastore provides support for memory diagnosis by leveraging a publish-subscribe infrastructure. In software architecture, publish-subscribe is a messaging pattern wherein a publisher (may be referred to as a “producer” in the contexts discussed herein) indirectly sends a message to a subscriber without directly sending the message to the subscriber. The publisher instead categorizes the message into classes without knowledge of the subscribers. Similarly, subscribers can express interest in one or more classes and only receive messages that are of interest. In the publish-subscribe messaging pattern, messages are “published” by publishers and then received by all appropriate subscribers. The datastore may leverage the publish-subscribe infrastructure for any application that needs a publish service hosted by itself or other applications.

[0042] In an embodiment, the datastore can be searched or queried by connected client accounts or networking devices. The datastore can return responses for customized searches using table indices. The datastore provides support for storing data across multiple data partitions. The data may be located across the multiple data partitions based on metadata stored locally on the datastore.

[0043] For purposes of furthering understanding of the disclosure, some explanation will be provided for numerous networking computing devices and protocols.

[0044] A BGP instance is a device for routing information in a network. A BGP instance may take the form of a route reflector appliance. The BGP instance may run on a switch, router, or BGP speakers on a switch. In an embodiment, the BGP instance sends all the paths it has learnt for a prefix to the best path controller. The best path controller responds with a set of best path from amongst those paths. The best path controller is permitted to modify the next-hop and attributes

for any of the paths. Once the best paths are received, the BGP instance updates the local Routing Information Base (RIB) and advertises the best path out to its neighbors.

[0045] A switch (may alternatively be referred to as a switching hub, bridging hub, or MAC bridge) creates a network. Most internal networks use switches to connect computers, printers, phones, camera, lights, and servers in a building or campus. A switch serves as a controller that enables networked devices to talk to each other efficiently. Switches connect devices on a computer network by using packet switching to receive, process, and forward data to the destination device. A network switch is a multiport network bridge that uses hardware addresses to process and forward data at a data link layer (layer 2) of the Open Systems Interconnection (OSI) model. Some switches can also process data at the network layer (layer 3) by additionally incorporating routing functionality. Such switches are commonly known as layer-3 switches or multilayer switches.

[0046] A router connects networks. Switches and routers perform similar functions, but each has its own distinct function to perform on a network. A router is a networking device that forwards data packets between computer networks. Routers perform the traffic directing functions on the Internet. Data sent through the Internet, such as a web page, email, or other form of information, is sent in the form of a data packet. A packet is typically forwarded from one router to another router through the networks that constitute an internetwork (*e.g.*, the Internet) until the packet reaches its destination node. Routers are connected to two or more data lines from different networks. When a data packet comes in on one of the lines, the router reads the network address information in the packet to determine the ultimate destination. Then, using information in the router's routing table or routing policy, the router directs the packet to the next network on its journey. A BGP speaker is a router enabled with the Border Gateway Protocol (BGP).

[0047] A routing table or routing information base (RIB) is a data table stored in a router or a networked computer that lists the routes to particular network destinations. In some cases, a routing table includes metrics for the routes such as distance, weight, and so forth. The routing table includes information about the topology of the network immediately around the router on which it is stored. The construction of routing tables is the primary goal of routing protocols. Static routes are entries made in a routing table by non-automatic means and which are fixed rather than being the result of some network topology discovery procedure. A routing table may include at least three information fields, including a field for network ID, metric, and next hop. The network ID is the destination subnet. The metric is the routing metric of the path through which the packet is to be sent. The route will go in the direction of the gateway with the lowest metric. The next hop is the address of the next station to which the packet is to be sent on the way to its final destination. The routing table may further include quality of service associate with the route, links to filtering criteria lists associated with the route, interface for an Ethernet card, and so forth.

[0048] For purposes of illustrating the concept of a routing table, the routing table may be analogized to using a map for delivering a package. A routing table is similar to the use of a map for delivering a package to its final destination. When a node needs to send data to another node on a network, the node must first know where to send the data. If the node cannot directly connect to the destination node, the node must send the data to other nodes along a proper route to the destination node. Most nodes do not try to figure out which routes might work. Instead, a node will send an IP packet to a gateway in the LAN, which then decides how to route the data to the correct destination. Each gateway will need to keep track of which way to deliver various packages of data, and for this it uses a routing table. A routing table is a database that keeps track of paths,

like a map, and uses these paths to determine which way to forward traffic. Gateways can also share the contents of their routing table with other nodes requesting the information.

[0049] For hop-by-hop routing, each routing table lists, for all reachable destinations, the address of the next device along the path to that destination, *i.e.* the next hop. Assuming the routing tables are consistent, the algorithm of relaying packets to their destination's next hop thus suffices to deliver data anywhere in a network. Hop-by-hop is a characteristic of an IP Internetwork Layer and the Open Systems Interconnection (OSI) model.

[0050] The Open Systems Interconnection (OSI) model is a conceptual model that characterizes and standardizes the communication functions of a computing system without regard to its underlying internal structure and technology. The goal of the OSI model is the interoperability of diverse communication systems with standard communication protocols. The OSI model partitions a communication system into abstraction layers. A layer serves the layer above it and is served by the layer below. For example, a layer that provides error-free communications across a network provides the path needed by applications above it, while it calls the next lower layer to send and receive packets that constitute the contents of that path. Two instances at the same layer are visualized as connected by a horizontal connection in that layer. Communication protocols enable an entity in one host to interact with a corresponding entity at the same layer in another host. Service definitions, like the OSI model, abstractly describe the functionality provided to an (N)-layer by an (N-1)-layer, wherein N is one of the layers of protocols operating in the local host.

[0051] Route control is a type of network management that aims to improve Internet connectivity and reduce bandwidth cost and overall internetwork operations. Some route control services include a suite of hardware-based and software-based products and services that work

together to improve overall Internet performance and finetune the use of available Internet bandwidth at minimal cost. Route control can be successful in scenarios where a network or autonomous system is sourcing Internet bandwidth from multiple providers. Route control can aid in the selection of the most optimal path for data transmission.

[0052] Some network communication systems are large, enterprise-level networks with thousands of processing nodes. The thousands of processing nodes share bandwidth from multiple Internet Service Providers (ISPs) and can process significant Internet traffic. Such systems can be extremely complex and must be properly configured to result in acceptable Internet performance. If the systems are not properly configured for optimal data transmission, the speed of Internet access can decrease, and the system can experience high bandwidth consumption and traffic. To counteract this problem, a set of services may be implemented to remove or reduce these concerns. This set of services may be referred to as routing control.

[0053] An embodiment of a routing control mechanism is composed of hardware and software. The routing control mechanism monitors all outgoing traffic through its connection with an Internet Service Provider (ISP). The routing control mechanism aids in selecting the best path for efficient transmission of data. The routing control mechanism may calculate the performance and efficiency of all ISPs and select only those ISPs that have performed optimally in applicable areas. Route control devices can be configured according to defined parameters pertaining to cost, performance, and bandwidth.

[0054] A known algorithm for determining the best path for the transmission of data is referred to as the Border Gateway Protocol (BGP). BGP is a path-vector protocol that provides routing information for autonomous systems on the Internet. When BGP is configured incorrectly, it can cause severe availability and security issues. Further, modified BGP route information can

permit attackers to redirect large blocks of traffic so the traffic travels to certain routers before reaching its intended destination. The BGP best path algorithm can be implemented to determine the best path to install in an Internet Protocol (IP) routing table for traffic forwarding. BGP routers may be configured to receive multiple paths to the same destination.

[0055] The BGP best path algorithm assigns a first valid path as the current best path. The BGP best path algorithm compares the best path with the next path in the list until the BGP reaches the end of the list of valid paths. The list provides the rules that are used to determine the best path. For example, the list may include an indication that the path with the highest weight is preferred, the path without a local preference is preferred, the path that was locally originated by way of a network or aggregate BGP is preferred, a shortest path is preferred, a path with the lowest multi-exit discriminator is preferred, and so forth. The BGP best path selection process can be customized.

[0056] In the context of BGP routing, each routing domain is known as an autonomous system (AS). BGP assists in selecting a path through the Internet to connect two routing domains. BGP typically selects a route that traverses the least number of autonomous systems, referred to as the shortest AS path. In an embodiment, once BGP is enabled, a router will pull a list of Internet routes from BGP neighbors which may be ISPs. BGP will then scrutinize the list to find routes with the shortest AS paths. These routes may be entered in the router's routing table. Generally, a router will choose the shortest path to an AS. BGP uses path attributes to determine how to route traffic to specific networks.

[0057] For the purposes of promoting an understanding of the principles in accordance with the disclosure, reference will now be made to the embodiments illustrated in the drawings and specific language will be used to describe the same. It will nevertheless be understood that no

limitation of the scope of the disclosure is thereby intended. Any alterations and further modifications of the inventive features illustrated herein, and any additional applications of the principles of the disclosure as illustrated herein, which would normally occur to one skilled in the relevant art and having possession of this disclosure, are to be considered within the scope of the disclosure claimed.

[0058] Before the structure, systems and methods for providing a datastore in a network computing environment are disclosed and described, it is to be understood that this disclosure is not limited to the particular structures, configurations, process steps, and materials disclosed herein as such structures, configurations, process steps, and materials may vary somewhat. It is also to be understood that the terminology employed herein is used for the purpose of describing particular embodiments only and is not intended to be limiting because the scope of the disclosure will be limited only by the appended claims and equivalents thereof.

[0059] In describing and claiming the subject matter of the disclosure, the following terminology will be used in accordance with the definitions set out below.

[0060] It must be noted that, as used in this specification and the appended claims, the singular forms “a,” “an,” and “the” include plural referents unless the context clearly dictates otherwise.

[0061] As used herein, the terms “comprising,” “including,” “containing,” “characterized by,” and grammatical equivalents thereof are inclusive or open-ended terms that do not exclude additional, unrecited elements or method steps.

[0062] As used herein, the phrase “consisting of” and grammatical equivalents thereof exclude any element or step not specified in the claim.

[0063] As used herein, the phrase “consisting essentially of” and grammatical equivalents thereof limit the scope of a claim to the specified materials or steps and those that do not materially affect the basic and novel characteristic or characteristics of the claimed disclosure.

[0064] Referring now to the figures, FIG. 1 illustrates a schematic diagram of a system 100 for connecting devices to the Internet. The system 100 includes multiple local area network 160 connected by a switch 106. Each of the multiple local area networks 160 can be connected to each other over the public Internet by way of a router 162. In the example system 100 illustrated in FIG. 1, there are two local area networks 160. However, it should be appreciated that there may be many local area networks 160 connected to one another over the public Internet. Each local area network 160 includes multiple computing devices 108 connected to each other by way of a switch 106. The multiple computing devices 108 may include, for example, desktop computers, laptops, printers, servers, and so forth. The local area network 160 can communicate with other networks over the public Internet by way of a router 162. The router 162 connects multiple networks to each other. The router 162 is connected to an internet service provider 102. The internet service provider 102 is connected to one or more network service providers 104. The network service providers 104 are in communication with other local network service providers 104 as shown in FIG. 1.

[0065] The switch 106 connects devices in the local area network 160 by using packet switching to receive, process, and forward data to a destination device. The switch 106 can be configured to, for example, receive data from a computer that is destined for a printer. The switch 106 can receive the data, process the data, and send the data to the printer. The switch 106 may be a layer-1 switch, a layer-2 switch, a layer-3 switch, a layer-4 switch, a layer-7 switch, and so forth. A layer-1 network device transfers data but does not manage any of the traffic coming through it. An example of a layer-1 network device is an Ethernet hub. A layer-2 network device is a multiport

device that uses hardware addresses to process and forward data at the data link layer (layer 2). A layer-3 switch can perform some or all of the functions normally performed by a router. However, some network switches are limited to supporting a single type of physical network, typically Ethernet, whereas a router may support different kinds of physical networks on different ports.

[0066] The router 162 is a networking device that forwards data packets between computer networks. In the example system 100 shown in FIG. 1, the routers 162 are forwarding data packets between local area networks 160. However, the router 162 is not necessarily applied to forwarding data packets between local area networks 160 and may be used for forwarding data packets between wide area networks and so forth. The router 162 performs traffic direction functions on the Internet. The router 162 may have interfaces for different types of physical layer connections, such as copper cables, fiber optic, or wireless transmission. The router 162 can support different network layer transmission standards. Each network interface is used to enable data packets to be forwarded from one transmission system to another. Routers 162 may also be used to connect two or more logical groups of computer devices known as subnets, each with a different network prefix. The router 162 can provide connectivity within an enterprise, between enterprises and the Internet, or between internet service providers' networks as shown in FIG. 1. Some routers 162 are configured to interconnecting various internet service providers or may be used in large enterprise networks. Smaller routers 162 typically provide connectivity for home and office networks to the Internet. The router 162 shown in FIG. 1 may represent any suitable router for network transmissions such as an edge router, subscriber edge router, inter-provider border router, core router, internet backbone, port forwarding, voice/data/fax/video processing routers, and so forth.

[0067] The internet service provider (ISP) 102 is an organization that provides services for accessing, using, or participating in the Internet. The ISP 102 may be organized in various forms,

such as commercial, community-owned, non-profit, or privately owned. Internet services typically provided by ISPs 102 include Internet access, Internet transit, domain name registration, web hosting, Usenet service, and colocation. The ISPs 102 shown in FIG. 1 may represent any suitable ISPs such as hosting ISPs, transit ISPs, virtual ISPs, free ISPs, wireless ISPs, and so forth.

[0068] The network service provider (NSP) 104 is an organization that provides bandwidth or network access by providing direct Internet backbone access to Internet service providers. Network service providers may provide access to network access points (NAPs). Network service providers 104 are sometimes referred to as backbone providers or Internet providers. Network service providers 104 may include telecommunication companies, data carriers, wireless communication providers, Internet service providers, and cable television operators offering high-speed Internet access. Network service providers 104 can also include information technology companies.

[0069] It should be appreciated that the system 100 illustrated in FIG. 1 is exemplary only and that many different configurations and systems may be created for transmitting data between networks and computing devices. Because there is a great deal of customizability in network formation, there is a desire to create greater customizability in determining the best path for transmitting data between computers or between networks. In light of the foregoing, disclosed herein are systems, methods, and devices for offloading best path computations to an external device to enable greater customizability in determining a best path algorithm that is well suited to a certain grouping of computers or a certain enterprise.

[0070] FIG. 2 illustrates a logical layout of data stored in a datastore 200 and the addressing mechanisms for accessing data within the datastore 200. The addressing mechanisms include the database URL 212, the table URL 214, and the object URL 216. The datastore 200 may be implemented as a client/server-based model of a publish-subscribe (“PUBSUB” or “Pub/Sub”)

database that offers enhanced flexibility. The datastore 200 may provide a two-hop data path between a producer and a subscriber with a database host server. The host server 310 may be inserted between the producer and the subscriber.

[0071] The datastore 200 includes a database directory tree 202 that includes an intermediate node 204 and a leaf node 206. The leaf node 206 is in communication with a table 210 stored in a database content tree 208. The table 210 stores information for multiple objects such as object1, object2, and object 3 as shown in FIG. 2. The leaf node 206 is accessible by way of a database URL 212. The database URL 212 may be provided to a client account for accessing the leaf node 206. Similarly, the table 210 is accessible by way of a table URL 214 and the objects are accessible by way of object URLs 216.

[0072] In an embodiment, the datastore 200 further includes a host library that allows apps to pose as a datastore host server 310 for data produced by an application. If the dataset is hosted and embedded on the host server and produced by the hosting app, an additional InterProcess Communication (IPC) hop may be avoided between the producer and the host server. In an embodiment, the datastore 210 may provide a one hop direct data path from a producer to a subscriber by combining a database host with the producer device.

[0073] Data may be stored in the hierarchal database directory tree 202. The database directory tree 202 may allow for wildcard subscriptions of data. A wildcard subscription may be an ad hoc, unexpected, one-off, or other singular event in which a subscriber, for example, requests data from a publisher. Wildcard subscriptions of the data may span over the dataset produced by more than one producer device. Alternatively, wildcard subscriptions may span over the dataset produced by more than one producer device. Alternatively, wildcard subscriptions may be hosted across multiple database host servers 310. When appropriately partitioned, the wildcard subscriptions

provide for effective horizontal scaling by providing a plurality of parallel data paths between producers and subscribers where the producer device includes the database host.

[0074] One advantage of the datastore as discussed herein is that the producer does not maintain the overhead of serving each subscriber by itself. Instead, overhead may be offloaded to one, or potentially a plurality, of the host server 310.

[0075] An additional advantage of the datastore as discussed herein is that an entire dataset produced by a single producer can be partitioned into subsets using appropriate data partitions. The data partitions can be assigned to different database host servers 310 as needed. This partitioning allows parallel data paths to be created between producers and subscribers while allowing for horizontal scaling. For example, a plurality of database host servers 310 can each create parallel data paths between producers and subscribers. Further, datastore 200 server components can be hosted on a separate server cluster to aid in offloading processing overhead to other devices.

[0076] In an embodiment, the datastore as discussed herein provides support for runtime diagnoses and system monitoring. For example, the datastore may collect diagnostic information from all datastore clients using the publish-subscribe infrastructure of the datastore.

[0077] FIG. 3 is a schematic diagram of a system 300 for offloading storage of best path computations and routes to a datastore 302. The system includes a datastore 302 in communication with multiple applications R1, R2, R3, Rn. The datastore 302 includes an index server 304 in communication with metadata 306. The metadata 306 provides an indication of where certain data is located within shared disk storage 312. The shared disk storage 312 includes a plurality of data storage devices 312a, 312b, 312c, 312n. The index server 304 is in communication with a processing platform 308 and the processing platform 308 has access to the shared disk storage 312.

The index server 304 is configured to provide an indication to the processing platform 308 of where certain data is located in the shared disk storage 312. The index server 304 makes this determination based on the metadata 306. The datastore 302 includes a host server 310 in communication with the processing platform 308. The host server 310 enables the processing platform 308 to write to the shared disk storage 312 by updating, adding, or deleting information in the shared disk storage 312. The processing platform 308 may include a plurality of hosts each comprising a processor and cache storage. Each of the hosts can be configured to read and write information in the shared disk storage 312.

[0078] FIG. 4 illustrates an embodiment wherein information is offloaded to a datastore 302 and the datastore 302 is local to a switch or router. The switch or router further includes hardware 416 and a software stack 414. The hardware 416 provides a physical connection that enables the transmission of data packets between computers or networks. The software stack 414 includes instructions to be implemented by a processor or hardware 416 for determining best paths and forwarding data packets along the best path for its destination device.

[0079] FIG. 5 illustrates an embodiment of a system 500 wherein information is offloaded to a datastore 302 and the datastore 302 is accessible over a cloud network 514. In an embodiment, the datastore 302 is a cloud-based database that is accessible by multiple networking devices R1, R2, R3, Rn.

[0080] FIG. 6 is a schematic diagram of communications between producers, producer consumers, and consumers within a datastore. In an embodiment, there is a datastore 602 local to the networking device that stores pertinent information for the system. The datastore 602 may be a database storing best path information for one or more routers or switches. The datastore 602 may further store system state information such as CPU utilization, temperature, fan speed, and

state information for peripherals such as LEDs or other devices. The datastore 602 may store a variety of information that may be useful to a monitoring agent. The information in the datastore 602 can be streamed out to another controller or device that could want such information. The datastore 602 may include a database index and may include multiple hosts. Each of the multiple hosts may include a processor and cache memory. In the example embodiment shown in FIG. 6, the datastore 602 includes a database host 1, a database host 2, a database host 3, and so on thru database host n.

[0081] The datastore 602 is in communication with a producer 604, a producer consumer 606, and a consumer 608. The producer 604 is an entity that creates data and adds to the datastore 602. A consumer 608 is an entity that reads data in the datastore 602. A producer consumer 606 is an entity that can produce a dataset and read a dataset in the datastore. In an embodiment, the producer consumer 606 can produce a first dataset in the datastore 602 and can read a second dataset in the datastore 602. The data includes, for example, status updates, computation results, state information, and so forth.

[0082] FIG. 7 is a schematic diagram of an embodiment of a datastore. The datastore shown in FIG. 7 illustrates a database cluster for multiple nodes in a single device of a datastore. The datastore may be implemented a publish-subscribe datastore. The datastore includes two nodes illustrated as discrete blocks. In the example implementation shown in FIG. 7, the datastore includes a NodeA and a NodeN. Each of the nodes include the same components connected by an internal fabric 726. The nodes each include a producer 704a, 704n in communication with a datastore client, a producer consumer 706a, 706n in communication with a datastore client, and a consumer 708a, 708n in communication with a datastore client. Each of the nodes includes a local datastore 702a, 702n for storing state information. The local datastore 702a, 702n includes a

database index along with multiple database hosts such as DB host 1, DB host 2, DB host 3, DB host n. The local datastore 702a, 702n is in communication with a replicator agent 712a, 712n. The replicator agent 712a, 712n is in communication with a datastore client 714a, 714n and includes replicator logic 716a, 716n. The persistent storage agent 718a, 718n is in communication with a datastore client 720a, 720n and has persistent storage 722a, 722n for storing data. The persistent storage agent 718a, 718n is in communication with disk storage 724a, 724n for storing data. The replicator agents 712a, 712n are in communication with internal fabric 726 for sharing datastore information between NodeA and NodeN and any other nodes that may also be connected to the internal fabric 726.

[0083] When the single node architecture shown in FIG. 7 is used, one or more separate database host servers may be implemented to provide data flows between a producer and a consumer, and to host the distributed datastore. The entire database may be partitioned into independent datasets. A hosting server process may be dedicated to one or more of the independent sets. A single database indexing server may be deployed to maintain mapping of hosting servers and corresponding datasets they host.

[0084] In an embodiment, a consumer 708a, 708n may connect to the database index server (see 304) by a datastore client. The database client can connect to the database index server 304 to register and subscribe interests in certain datasets. Producers 704a, 704n may connect to the database index server 304 by a datastore client to receive information about which hosting server to use and further to receive updates about the database. The producer 704a, 704n can connect to a specific hosting server and publish additions, modifications, deletions, and data objects. Consumers 708a, 708n may be notified by the database index server 304 of new, modified, and/or

deleted objects and be connected to appropriate hosting servers to download datasets produced by producers 704a, 704n.

[0085] A separate datastore replicator agent 712a, 712n may connect to the datastore 702a, 702n as a datastore client acting both as a consumer and producer. The replicator agent 712a, 712n is used to assist in replicating database to and from other nodes in the same device. The replicator agent 712a, 712n may act as a consumer for all data objects produced on the local node and act as a producer for all data objects produced on a remote node.

[0086] A separate persistent storage agent 718a, 718n may connect to the datastore 702a, 702n as both a producer and consumer and help store and restore data objects to a persistent memory storage device such as persistent storage 722a, 722n or disk 724a, 724n.

[0087] As database size increases, more servers may be deployed to balance load distribution. The database may be partitioned into independent partitions allowing each server to host a subset of the partitions.

[0088] FIG. 8 is a schematic diagram illustrating multiple devices being controlled by remote controller logic 812 offloaded to a cloud computing network. Each device, including Device1, Device2, and DeviceN includes one or more nodes, namely Node1, Node2, and NodeN. In the embodiment shown in FIG. 8 there are illustrated three separate devices, but it should be appreciated there may be any number of devices and nodes without departing from the scope of the disclosure. Each device includes a configuration agent 806 receiving communications from the controller logic 812 by way of the cloud network 814. Each device includes a monitoring and telemetry agent 808 providing data to the controller logic 812 by way of the cloud network 814. Each device includes a datastore 802 and one or more applications in communication with the datastore 802.

[0089] The devices and the nodes are separate and independent, and each include their own datastore. There is no datastore replication between the devices and the nodes. The devices and nodes individually send data from their respective monitoring and telemetry agents 808. The controller logic 812 performs processing based on the combined data from the multiple devices and nodes and sends each node configuration updates based on the results of the processing.

[0090] FIG. 9 is a schematic diagram of an embodiment of a database cluster of a multiple node architecture for a datastore hosted in the cloud. The datastore 902 is in communication with producers 904a, 904n, producer consumers 906a, 906n, and consumers 908a, 908n from multiple devices. In the example implementation illustrated in FIG. 9, the datastore 902 is in communication with producers, producer consumers, and consumers from two separate devices. The datastore 902 includes a database index and multiple database hosts such as database host 1, database host 2, database host 3, and up thru database host n as illustrated. The datastore 902 may have any number of database hosts in various embodiments. The datastore 902 is in communication with a persistent storage agent 918. The persistent storage agent 918 is in communication with a datastore client 920 and includes persistent storage 922. The persistent storage agent 918 stores information in disk storage 924. All communication channels between producer 904a, 904n and database index, database host to N can be secured (authenticated and encrypted) via SSL or similar mechanism. This maintains privacy of data exchanged between the components.

[0091] The datastore 902 and the persistent storage agent 918 may be offloaded to a cloud network 928 to be stored in cloud-based storage. The datastore 902 and the data stored in the disk storage 924 may be accessed by multiple different devices. The datastore 902 may be made accessible to a client account by way of a datastore URL. The datastore 902 may be stored across one more deployments of cloud-based storage across one or more cloud networks 928. The

datastore 902 may be accessible in multiple geographic locations. The datastore 902 may be also stored locally in networking devices or may be solely stored in cloud-based storage.

[0092] FIG. 10 is a schematic diagram of system 1000 for communication between a node 1004 of a device 1010 and controller logic 1012 stored in a cloud network 1028. The device 1010 may be a switch 106 or a router 162 as discussed herein. The node 1004 includes a configuration agent 1006 and a monitoring/telemetry agent 1008. The device 1010 includes a datastore 1002. The datastore 1002 may be stored locally with the node 1004, may be stored in the device 1010 and made accessible to multiple nodes, may be offloaded to cloud storage, or may be stored externally and made accessible to multiple devices 1002. The configuration agent 1006 receives instructions in the form of controller logic 1012. The controller logic 1012 is stored in cloud-based storage on a cloud network and is made accessible to the device 1010 over a network. The configuration agent 1006 provides instructions to the monitoring/telemetry agent 1008. The monitoring/telemetry agent 1008 receives information from the datastore 1002. The datastore 1002 may include information for multiple applications such as application 1, application 2, and up thru application N as shown. All communication channels between configuration agent 1006 and controller logic 1012, and between monitoring and telemetry agent 1008 and controller logic 1012 can be secured (authenticated and encrypted) using SSL or similar such mechanism to maintain privacy of data exchanged amongst the components.

[0093] The configuration agent 1006 is responsible for managing configuration on a networking device. The configuration agent 1105 typically provides a command-line interface or NETCONF or RESTCONF or some other interface to configure and provision a networking device. Certain applications running on that networking device such as BGP or routing information base (RIB) may be notified of configuration changes by the configuration agent 1006. The

configuration agent 1006 provides a mechanism where these applications can read the configuration and act accordingly.

[0094] The monitoring and telemetry agent 1008 subscribes to changes in a datastore and transmits those changes over a connection to an external entity such as a controller. The controller receives the telemetry data from multiple devices and may perform some analysis across devices and push back configuration updates to optimize the operations across devices. For illustration purposes, the telemetry may be similar simple network management protocol (SNMP), but instead of periodic polling, the monitoring and telemetry agent 1008 pushes updates to an external monitoring device.

[0095] The controller logic 1012 may alternatively be referred to as a controller. The controller logic 1012 manages multiple devices. The controller logic 1012 pushes configuration updates to the multiple devices and receives status information from the multiple devices by way of updates received from the monitoring and telemetry agent 1108. The controller logic 1012 can perform analysis such as a Best Path calculation across the route data from multiple devices and push appropriate results back to each device. This may provide improved overall network performance compared with each device performing its own best path calculation locally.

[0096] The applications are programs or services that perform operations based on the data in the datastore 1002. Example applications include Border Gateway Protocol (BGP), intermediate system to intermediate system (ISIS), routing information base (RIB), open shortest path first (OSPF), and so forth.

[0097] FIG. 11 is a schematic diagram of a system for offloading controller logic for a multi-node device to a cloud-based controller. The example architecture 1100 includes two nodes shown as discrete blocks Node1 and NodeN. It should be appreciated there may be any number of nodes

suitable to different embodiments and implementations of the disclosure. Node1 includes a replicator agent 1104 in communication with the internal fabric 1126 that provides communication with the replicator agent 1104 of NodeN. The replicator agent 1104 is responsible for keeping data consistent between different instances of the datastore. The replicator agent 1104 replicates changes in one datastore to another datastore for redundancy or clustering purposes. The configuration agent 1106 of Node1 is in communication with the cloud 1128 network which includes the controller logic 1112 for the datastore 1102. Each of the nodes includes a copy of the datastore 1102. The information in the datastore 1102 may be accessed and used by multiple applications such as application1, application2, and up thru applicationN. The monitoring and telemetry agent 1108 of NodeN is in communication with the datastore 1102 and the cloud 1128 network. The configuration agent 1106 of Node1 can be in communication with the monitoring and telemetry agent 1108 of NodeN by way of the cloud 1128 network.

[0098] FIG. 12 is a schematic diagram of a direct inter-process communication (IPC) model of a datastore 1202. The inter-process communication channels are illustrated in dotted lines. The difference between the dotted lines (IPC) and the solid lines is that the IPC connections bypass the datastore. The IPC connections connect the datastore clients directly with each other and hence are one hop less than the solid lines which go via the datastore. The IPC channels exist between the datastore clients of the producer 1204, the producer consumer 1206, and the consumer 1208 with the datastore client 1214 of the replicator agent 1210 and the datastore client 1220 of the persistent storage agent 1218 as shown. Each of the nodes, including Node1 and NodeN maintains its own datastore 1202. Each node includes one or more producers 1204, producer consumers 1206, and consumers 1208. Each node includes a replicator agent 1210 including a datastore client 1214 and

replicator logic 1216. Each node includes a persistent storage agent 1218 including a datastore client 1220 and persistent storage 1222 that offloads storage to disk 1224 storage.

[0099] FIG. 13 is a schematic diagram of an index server 304 of a datastore. Embodiments of the datastore may include an index server 304 and a host server 310. The index server 304 may be used in conjunction with the datastore in single and multiple node embodiments. The index server 304 includes a host server database 1304 storing host server information 1306. The index server 304 includes a client server connection to database 1308 that facilitates a client server connection 1310. The index server 304 includes a data partition database 1312 that includes data partition information 1314. The index server 120 includes a data subscribe database 1316 that includes data subscribe information 1318.

[0100] The index server 304 manages datastore operations and queries. The index server 304 knows what information is anchored on which host device in the datastore. The datastore includes multiple host devices each serving as an execution node in an execution platform. Each host device may include one or more processors and cache memory. The index server 304 can read metadata to determine what information is already stored locally in cache memory in each of the multiple hosts. The index server 304 is configured to perform load balancing operations for each of the multiple host instances in the datastore.

[0101] FIG. 14 is a schematic diagram of a host server 310 of a datastore. The host server may be used in conjunction with the datastore in single or multiple node architectures. The host server 310 facilitates an index server connection 1404 to a client server connection 1410 such that a client can access and query the datastore. The host server 310 facilitates a client database connection 1406 to generate a client server connection to the datastore 1408. The host server 310 includes a data subscribe database 1412 that facilitates a subscriber connection 1414 to access data

partition information 1416. The host server 310 includes a data partition database 1418 that includes data subscribe information 1420.

[0102] The host server 310 provides connection to data within the datastore after an initial connection is established between a networking device and the datastore. The initial connection may be established by the index server 304. The host server 310 provides an indication of where data is within the data server. The host server 310 allows writing on the data stored in the datastore.

[0103] FIG. 15 is a schematic diagram of a process flow 1500 for data operations in a publish-subscribe datastore. The process flow 1500 may be implemented by a datastore 1502, a publisher device 1504, and a subscriber device 1506. Each of the publisher device 1504 and the subscriber device 1506 may be a BGP instance and/or a networking device such as a router or switch. The publisher device 1504 and the subscriber device 1506 may include some local storage and may be configured to offload large sums of data to the datastore 1502. A copy of at least a portion of the datastore 1502 may be stored locally in the publisher device 1504 and/or the subscriber device. The datastore 1502 may be stored in cloud-based storage and may be made accessible to the publisher device 1504 and/or the subscriber device 1506 by way of a network connection.

[0104] In the process flow 1500, the publisher device 1504 determines data to be stored and stores the data locally at 1508. The data may include, for example, state information for the device such as CPU utilization, temperature, fan speed, status of peripherals, and so forth. State information for the device can be useful to a monitoring agent and may be streamed out to other controllers or devices that want such information. The data may include best path information indicating the hops required to transmit data from a first location to a final destination. The best path information may be determined by the device locally according to the BGP. The best path

information may be determined by a best path controller. The best path information may be published to the datastore such that it can be retrieved by all subscriber devices.

[0105] In the process flow, the publisher device 1504 publishes the data at 1510 to the datastore 1502. The datastore 1502 stores the data and makes the data available at 1512. The subscriber device 1506 may receive a notification from the datastore 1502 indicating the data is available. The subscriber device 1506 requests the data at 1514. The datastore 1502 queries the data stored within the datastore 1502 to provide a response to the subscriber device 1506. The subscriber device 1506 receives the data at 1516.

[0106] In an embodiment, the data is encrypted by the publisher device 1504 and/or the datastore 1502 and/or the subscriber device 1506. The datastore 1502 may encrypt the data and provide encrypted data to the subscriber device 1506. The datastore 1502 may perform authentications to ensure the subscriber device 1506 has permissions to read the data.

[0107] The process flow 1500 and the use of a datastore 1502 in a network computing environment enables numerous benefits. The datastore 1502 serves as an external database that stores replicated data for the devices. The datastore 1502 can be located externally to the devices. The datastore 1502 may receive an indication of all devices that are connected to the datastore 1502 and can receive and requests communications with the datastore 1502. This enables numerous benefits. The datastore 1502 can serve as a central agent that is aware of the state of all devices connected to the datastore 1502. The datastore 1502 can further serve as a central agent that knows what type of software, and what version of that software, is being run on each device in communication with the datastore 1502.

[0108] The data stored in the datastore 1502 can be used to restart operations in the event of a crash. If one or more devices fail due to an intermittent fault or a regression, the data in the

datastore 1502 can be retrieved to resume operations as if the failure never occurred. The datastore 1502 serves as a backup for each of the devices in the datastore's 1502 network.

[0109] The information in the datastore 1502 can be provided to multiple subscriber devices 1506 at one time. This enables numerous benefits and prevents publisher devices 1504 from becoming backlogged by servicing information requests from subscriber devices 1506. For example, a computer network may include numerous devices and those devices may share best path information. In the example, the computer network includes three devices, device1, device2, and device 3. In an implementation, device1 and device2 each require information from device3. If device3 must respond to these requests, then the processing and storage resources device3 can be logged down with servicing requests. However, if the computer network includes a datastore 1502, device3 can instead publish the information to the datastore 1502, the datastore 1502 can store in the information, and the datastore 1502 can handle any requests for data from the other devices. This frees up processing and memory resources in each of the devices for performing higher priority operations to ensure smooth operation of data transmission throughout the computer network and into outside computer networks.

[0110] FIG. 16 is a schematic diagram of a storage structure 1600 for storing metadata on database content. The storage structure 1600 provides an exemplary embodiment of data storage in a datastore as discussed herein. The datastore may employ a user-defined data model via JSON (Java Script Object Notation) data schema definition standards. The data model may provide structure for tables, objects, and attributes in a hierarchical system. For example, the datastore may allow any application, including third party applications, to define a JSON-based data model and use APIs (application program interfaces) to produce and subscribe to data adhering to the same JSON-based data model.

[0111] The storage structure 1600 illustrated in FIG. 16 includes database metadata 1602 for all table types 1606 in the database and all object types 1604 in the database. The database metadata 1602 for the all table types 1606 includes table definitions such as table definition 1, table definition 2, and up thru table definition n as shown in FIG. 16. The table definitions can be defined by table indexes 1608. The database metadata 1052 may include a table index for each table definition such as table index 1, table index 2, and up thru table index n. Each of the table indexes may include an attribute definition such as attribute definition 1, attribute definition 2, and up thru attribute definition n. The database metadata 1602 for the all object types 1604 may include an object definition for each object in the database, such as object definition 1, object definition 2, and up thru object definition n. The object definitions may further be associated with database metadata 1602 for all attribute types 1610.

[0112] In an embodiment, the datastore storage structure is specified by user-defined schema. The user-defined schema may be specified in JSON or in any other suitable language. In such an embodiment, the datastore can be fully customized to provide built in support for a multitude of datatypes for attributes, including array and sub objects. Further, this embodiment provides support for indexing objects under tables using indexing mechanisms. In an embodiment, the datastore can be stored in a JSON/XML format which may facilitate encapsulating the data in a REST (Representation State Transfer) and telemetry interface. The REST and telemetry interface may facilitate monitoring an analysis by a remote computing entity for determining the efficiency of the database. The data schema definition for the datastore may allow data to be provided from a REST/NETCONF interface in a manner that conforms to the data mode already defined for the data.

[0113] FIG. 17 is a schematic block diagram of a method 1700 for offloading storage of data from networking device to a datastore. The method 1700 can be performed by a datastore as discussed herein or any suitable computing device. The method 1700 may be performed by an index server 304 and/or a host server 310 of a datastore as discussed herein.

[0114] The method 1700 includes receiving at 1702, by a datastore in a network computing environment, data from a publisher device, wherein the datastore is independent of the publisher device. The method 1700 includes partitioning at 1704 the data into one or more database partitions according to database schema. The method 1700 includes storing at 1706 the data across one or more of a plurality of shared storage devices accessible by a plurality of hosts in a processing platform. The method 1700 includes receiving at 1708 a request for the data from a subscriber device, wherein the datastore is independent of the subscriber device. The method 1700 includes providing at 1710 the data to the subscriber device.

[0115] FIG. 18 is a schematic block diagram of a method 1800 for managing one or more datastores of a networking device. The method 1800 can be performed by an index server 304 as discussed herein or by any other suitable computing device.

[0116] The method 1800 begins and a computing device maintains at 1802 a database index comprising a mapping of datasets in a datastore of a networking device. The method 1800 continues and a computing device maintains at 1804 a list of publishers and subscribers for each of the datasets in the datastore. The method 1800 continues and a computing device updates at 1806 the database index in response to receiving a notification that one or more of the datasets in the datastore has been modified. The method 1800 continues and a computing device updates at 1808 the list of publishers and subscribers in response to receiving a notification from a subscriber indicating a desire to subscribe to a certain dataset.

[0117] Referring now to FIG. 19, a block diagram of an example computing device 1900 is illustrated. Computing device 1900 may be used to perform various procedures, such as those discussed herein. In one embodiment, the computing device 1900 can function as a datastore, including an index server 304 and/or a host server 310. Computing device 1900 can perform various monitoring functions as discussed herein, and can execute one or more application programs, such as the application programs or functionality described herein. Computing device 1900 can be any of a wide variety of computing devices, such as a desktop computer, in-dash computer, vehicle control system, a notebook computer, a server computer, a handheld computer, tablet computer and the like.

[0118] Computing device 1900 includes one or more processor(s) 1902, one or more memory device(s) 1904, one or more interface(s) 1906, one or more mass storage device(s) 1908, one or more Input/output (I/O) device(s) 1902, and a display device 1930 all of which are coupled to a bus 1912. Processor(s) 1902 include one or more processors or controllers that execute instructions stored in memory device(s) 1904 and/or mass storage device(s) 1908. Processor(s) 1902 may also include various types of computer-readable media, such as cache memory.

[0119] Memory device(s) 1904 include various computer-readable media, such as volatile memory (e.g., random access memory (RAM) 1914) and/or nonvolatile memory (e.g., read-only memory (ROM) 1916). Memory device(s) 1904 may also include rewritable ROM, such as Flash memory.

[0120] Mass storage device(s) 1908 include various computer readable media, such as magnetic tapes, magnetic disks, optical disks, solid-state memory (e.g., Flash memory), and so forth. As shown in FIG. 19, a particular mass storage device is a hard disk drive 1924. Various drives may also be included in mass storage device(s) 1908 to enable reading from and/or writing

to the various computer readable media. Mass storage device(s) 1908 include removable media 1926 and/or non-removable media.

[0121] Input/output (I/O) device(s) 1902 include various devices that allow data and/or other information to be input to or retrieved from computing device 1900. Example I/O device(s) 1902 include cursor control devices, keyboards, keypads, microphones, monitors or other display devices, speakers, printers, network interface cards, modems, and the like.

[0122] Display device 1930 includes any type of device capable of displaying information to one or more users of computing device 1900. Examples of display device 1930 include a monitor, display terminal, video projection device, and the like.

[0123] Interface(s) 1906 include various interfaces that allow computing device 1900 to interact with other systems, devices, or computing environments. Example interface(s) 1906 may include any number of different network interfaces 1920, such as interfaces to local area networks (LANs), wide area networks (WANs), wireless networks, and the Internet. Other interface(s) include user interface 1918 and peripheral device interface 1922. The interface(s) 1906 may also include one or more user interface elements 1918. The interface(s) 1906 may also include one or more peripheral interfaces such as interfaces for printers, pointing devices (mice, track pad, or any suitable user interface now known to those of ordinary skill in the field, or later discovered), keyboards, and the like.

[0124] Bus 1912 allows processor(s) 1902, memory device(s) 1904, interface(s) 1906, mass storage device(s) 1908, and I/O device(s) 1902 to communicate with one another, as well as other devices or components coupled to bus 1912. Bus 1912 represents one or more of several types of bus structures, such as a system bus, PCI bus, IEEE bus, USB bus, and so forth.

[0125] For purposes of illustration, programs and other executable program components are shown herein as discrete blocks, although it is understood that such programs and components may reside at various times in different storage components of computing device 1900 and are executed by processor(s) 1902. Alternatively, the systems and procedures described herein can be implemented in hardware, or a combination of hardware, software, and/or firmware. For example, one or more application specific integrated circuits (ASICs) can be programmed to carry out one or more of the systems and procedures described herein.

[0126] The foregoing description has been presented for the purposes of illustration and description. It is not intended to be exhaustive or to limit the disclosure to the precise form disclosed. Many modifications and variations are possible in light of the above teaching. Further, it should be noted that any or all of the aforementioned alternate implementations may be used in any combination desired to form additional hybrid implementations of the disclosure.

[0127] Further, although specific implementations of the disclosure have been described and illustrated, the disclosure is not to be limited to the specific forms or arrangements of parts so described and illustrated. The scope of the disclosure is to be defined by the claims appended hereto, if any, any future claims submitted here and in different applications, and their equivalents.

### Examples

[0128] The following examples pertain to further embodiments.

[0129] Example 1 is a system. The system includes a plurality of instances of a datastore node in a single networking device, each of the plurality of instances of the datastore node comprising: a datastore; a publisher independent of the datastore for publishing data to the datastore; a subscriber independent of the datastore for receiving information from the datastore; a replicator

agent configured to connect to the datastore as a publisher or a subscriber; and a persistent storage agent configured to connect to the datastore as a publisher or a subscriber.

[0130] Example 2 is a system as in Example 1, wherein the replicator agent is configured to replicate database data from other instances of the datastore node in the same single networking device by: connecting to the datastore as an acting publisher for data objects produced on a local instance of the datastore node; and connecting to the datastore as an acting consumer for data objects produced on remote instances of the datastore node.

[0131] Example 3 is a system as in any of Examples 1-2, wherein the persistent storage agent is configured to store data objects to a persistent data storage device.

[0132] Example 4 is a system as in any of Examples 1-3, wherein the persistent data storage device comprises a plurality of shared storage devices collectively storing a plurality of dataset, wherein each of the plurality of shared storage devices is accessible by each instance of a host server.

[0133] Example 5 is a system as in any of Examples 1-4, further comprising a single instance of an index server configured to: maintain a database index comprising a mapping of datasets in the datastore; and maintain a list of publishers and subscribers for each of the datasets in the datastore.

[0134] Example 6 is a system as in any of Examples 1-5, wherein the index server is configured to receive a notification from a subscriber to subscribe to a certain dataset.

[0135] Example 7 is a system as in any of Examples 1-6, wherein the index server is configured to receive a notification from a publisher to update the database index to reflect an update to one or more of the datasets in the datastore.

[0136] Example 8 is a system as in any of Examples 1-7, wherein each of the plurality of instances of the datastore node further comprises: an index server for receiving data processing requests from a plurality of subscriber devices; metadata accessible to the index server; a host server in communication with the datastore; and a plurality of shared storage devices collectively storing a plurality of datasets in the datastore.

[0137] Example 9 is a system as in any of Examples 1-8, further comprising controller logic offloaded to cloud-based storage, wherein the controller logic is accessible to each of the plurality of instances of the datastore node.

[0138] Example 10 is a system as in any of Examples 1-9, wherein the networking device is a switch or router.

[0139] Example 11 is an index server of a datastore, the index server comprising one or more processors configurable to execute instructions stored in non-transitory computer readable storage media, the instructions comprising: maintaining a database index comprising a mapping of datasets in the datastore; maintaining a list of publishers and subscribers for each of the datasets in the datastore; updating the database index in response to receiving a notification that one or more of the datasets in the datastore has been modified; and updating the database index in response to receiving a notification from a subscriber indicating a desire to subscribe to a certain dataset.

[0140] Example 12 is an index server as in Example 11, wherein the index server is a single instance of an index server managing a plurality of instances of the datastore in a single networking device.

[0141] Example 13 is an index server as in any of Examples 11-12, wherein the instructions further comprise retrieving controller logic from cloud-based storage.

[0142] Example 14 is an index server as in any of Examples 11-13, wherein the instructions further comprise receiving a message from a replicator agent configured to replicate datasets in the datastore to and from other instances of the datastore located in a single networking device, wherein the replicator agent can interact with the index server as a publisher or as a subscriber.

[0143] Example 15 is an index server as in any of Examples 11-14, wherein the instructions further comprise receiving a message from a persistent storage agent configured to store data objects in a persistent data storage device, wherein the persistent storage agent can interact with the index server as a publisher or as a subscriber.

[0144] Example 16 is a method for managing a multiple node architecture of a datastore, the method comprising: maintaining a database index comprising a mapping of datasets in the datastore; maintaining a list of publishers and subscribers for each of the datasets in the datastore; updating the database index in response to receiving a notification that one or more of the datasets in the datastore has been modified; and updating the database index in response to receiving a notification from a subscriber indicating a desire to subscribe to a certain dataset.

[0145] Example 17 is a method as in any of Examples 11-16, wherein the method is performed by an index server and the index server is a single instance of an index server managing a plurality of instances of the datastore in a single networking device.

[0146] Example 18 is a method as in any of Examples 11-17, further comprising retrieving controller logic from cloud-based storage.

[0147] Example 19 is a method as in any of Examples 11-18, further comprising receiving a message from a replicator agent configured to replicate datasets in the datastore to and from other instances of the datastore located in a single networking device, wherein the replicator agent can interact with the index server as a publisher or as a subscriber.

[0148] Example 20 is a method as in any of Examples 11-19, further comprising receiving a message from a persistent storage agent configured to store data objects in a persistent data storage device, wherein the persistent storage agent can interact with the index server as a publisher or as a subscriber.

[0149] It is to be understood that any features of the above-described arrangements, examples, and embodiments may be combined in a single embodiment comprising a combination of features taken from any of the disclosed arrangements, examples, and embodiments.

[0150] It will be appreciated that various features disclosed herein provide significant advantages and advancements in the art. The following claims are exemplary of some of those features.

[0151] In the foregoing Detailed Description of the Disclosure, various features of the disclosure are grouped together in a single embodiment for the purpose of streamlining the disclosure. This method of disclosure is not to be interpreted as reflecting an intention that the claimed disclosure requires more features than are expressly recited in each claim. Rather, inventive aspects lie in less than all features of a single foregoing disclosed embodiment.

[0152] It is to be understood that the above-described arrangements are only illustrative of the application of the principles of the disclosure. Numerous modifications and alternative arrangements may be devised by those skilled in the art without departing from the spirit and scope of the disclosure and the appended claims are intended to cover such modifications and arrangements.

[0153] Thus, while the disclosure has been shown in the drawings and described above with particularity and detail, it will be apparent to those of ordinary skill in the art that numerous modifications, including, but not limited to, variations in size, materials, shape, form, function and

manner of operation, assembly and use may be made without departing from the principles and concepts set forth herein.

[0154] Further, where appropriate, functions described herein can be performed in one or more of: hardware, software, firmware, digital components, or analog components. For example, one or more application specific integrated circuits (ASICs) or field programmable gate arrays (FPGAs) can be programmed to carry out one or more of the systems and procedures described herein. Certain terms are used throughout the following description and claims to refer to particular system components. As one skilled in the art will appreciate, components may be referred to by different names. This document does not intend to distinguish between components that differ in name, but not function.

[0155] The foregoing description has been presented for the purposes of illustration and description. It is not intended to be exhaustive or to limit the disclosure to the precise form disclosed. Many modifications and variations are possible in light of the above teaching. Further, it should be noted that any or all the aforementioned alternate implementations may be used in any combination desired to form additional hybrid implementations of the disclosure.

[0156] Further, although specific implementations of the disclosure have been described and illustrated, the disclosure is not to be limited to the specific forms or arrangements of parts so described and illustrated. The scope of the disclosure is to be defined by the claims appended hereto, any future claims submitted here and in different applications, and their equivalents.

**CLAIMS**

What is claimed is:

1. A system comprising:

a plurality of instances of a datastore node in a single networking device, each of the plurality of instances of the datastore node comprising:

a datastore;

a publisher independent of the datastore for publishing data to the datastore;

a subscriber independent of the datastore for receiving information from the datastore;

a replicator agent configured to connect to the datastore as a publisher or a subscriber; and

a persistent storage agent configured to connect to the datastore as a publisher or a subscriber.

2. The system of claim 1, wherein the replicator agent is configured to replicate database data from other instances of the datastore node in the same single networking device by:

connecting to the datastore as an acting publisher for data objects produced on a local instance of the datastore node; and

connecting to the datastore as an acting consumer for data objects produced on remote instances of the datastore node.

3. The system of claim 1, wherein the persistent storage agent is configured to store data objects to a persistent data storage device.

4. The system of claim 3, wherein the persistent data storage device comprises a plurality of shared storage devices collectively storing a plurality of dataset, wherein each of the plurality of shared storage devices is accessible by each instance of a host server.
  
5. The system of claim 1, further comprising a single instance of an index server for managing the plurality of instances of the datastore node, the index server configured to:
  - maintain a database index comprising a mapping of datasets in the datastore; and
  - maintain a list of publishers and subscribers for each of the datasets in the datastore.
  
6. The system of claim 5, wherein the index server is configured to receive a notification from a subscriber to subscribe to a certain dataset.
  
7. The system of claim 5, wherein the index server is configured to receive a notification from a publisher to update the database index to reflect an update to one or more of the datasets in the datastore.
  
8. The system of claim 1, wherein each of the plurality of instances of the datastore node further comprises:
  - an index server for receiving data processing requests from a plurality of subscriber devices;
  - metadata accessible to the index server;
  - a host server in communication with the datastore; and

a plurality of shared storage devices collectively storing a plurality of datasets in the datastore.

9. The system of claim 1, further comprising controller logic offloaded to cloud-based storage, wherein the controller logic is accessible to each of the plurality of instances of the datastore node.

10. The system of claim 1, wherein the networking device is a switch or router.

11. An index server of a datastore, the index server comprising one or more processors configurable to execute instructions stored in non-transitory computer readable storage media, the instructions comprising:

maintaining a database index comprising a mapping of datasets in the datastore;

maintaining a list of publishers and subscribers for each of the datasets in the datastore;

updating the database index in response to receiving a notification that one or more of the datasets in the datastore has been modified; and

updating the list of publishers and subscribers in response to receiving a notification from a subscriber indicating a desire to subscribe to a certain dataset.

12. The index server of claim 11, wherein the index server is a single instance of an index server managing a plurality of instances of the datastore in a single networking device.

13. The index server of claim 11, wherein the instructions further comprise retrieving controller logic from cloud-based storage.

14. The index server of claim 11, wherein the instructions further comprise receiving a message from a replicator agent configured to replicate datasets in the datastore to and from other instances of the datastore located in a single networking device, wherein the replicator agent can interact with the index server as a publisher or as a subscriber.

15. The index server of claim 11, wherein the instructions further comprise receiving a message from a persistent storage agent configured to store data objects in a persistent data storage device, wherein the persistent storage agent can interact with the index server as a publisher or as a subscriber.

16. A method for managing a multiple node architecture of a datastore, the method comprising:  
maintaining a database index comprising a mapping of datasets in the datastore;  
maintaining a list of publishers and subscribers for each of the datasets in the datastore;  
updating the database index in response to receiving a notification that one or more of the datasets in the datastore has been modified; and  
updating the list of publishers and subscribers in response to receiving a notification from a subscriber indicating a desire to subscribe to a certain dataset.

17. The method of claim 16, wherein the method is performed by an index server and the index server is a single instance of an index server managing a plurality of instances of the datastore in a single networking device.

18. The method of claim 16, further comprising retrieving controller logic from cloud-based storage.

19. The method of claim 16, further comprising receiving a message from a replicator agent configured to replicate datasets in the datastore to and from other instances of the datastore located in a single networking device, wherein the replicator agent can interact with the index server as a publisher or as a subscriber.

20. The method of claim 16, further comprising receiving a message from a persistent storage agent configured to store data objects in a persistent data storage device, wherein the persistent storage agent can interact with the index server as a publisher or as a subscriber.

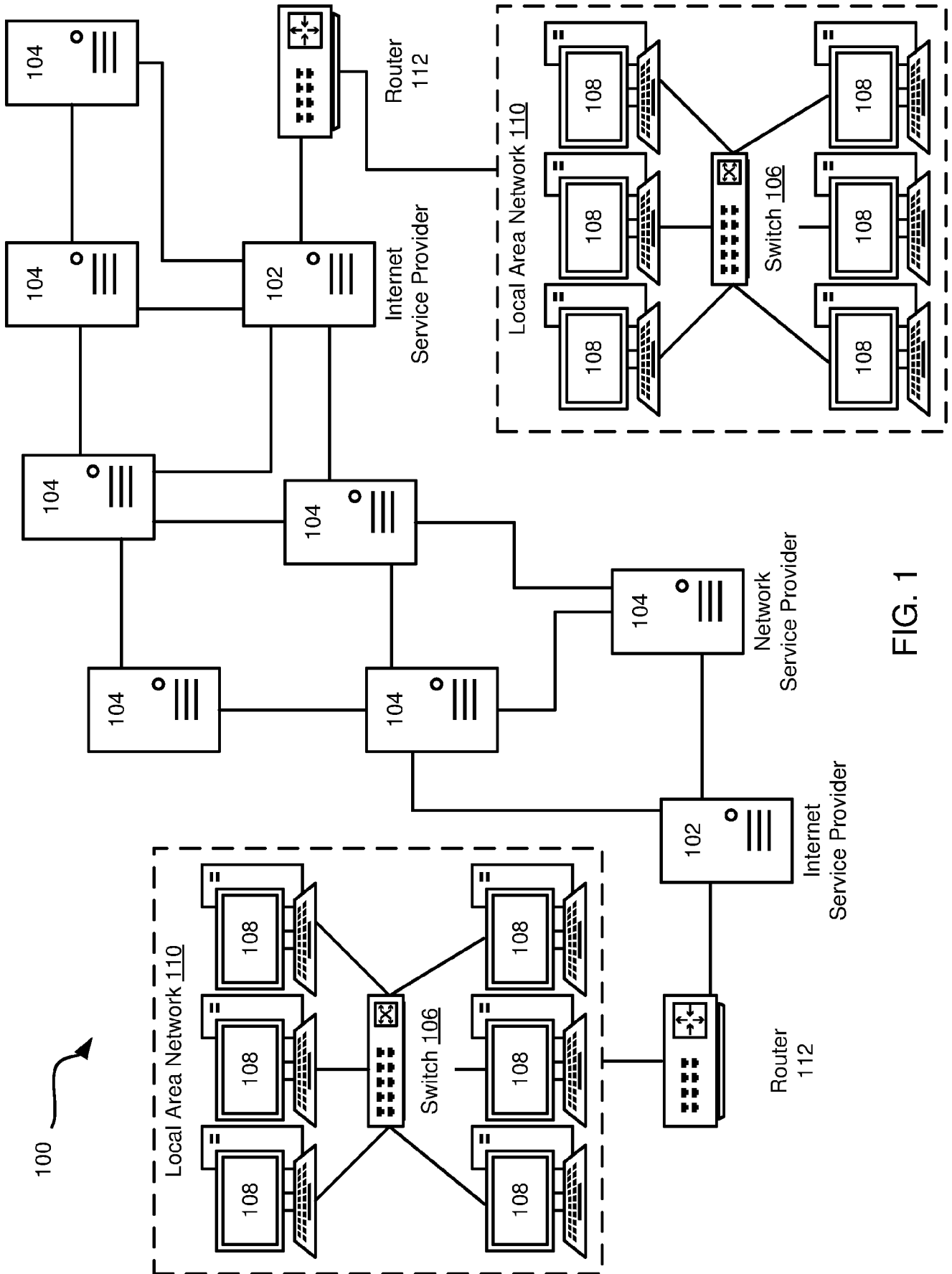

FIG. 1

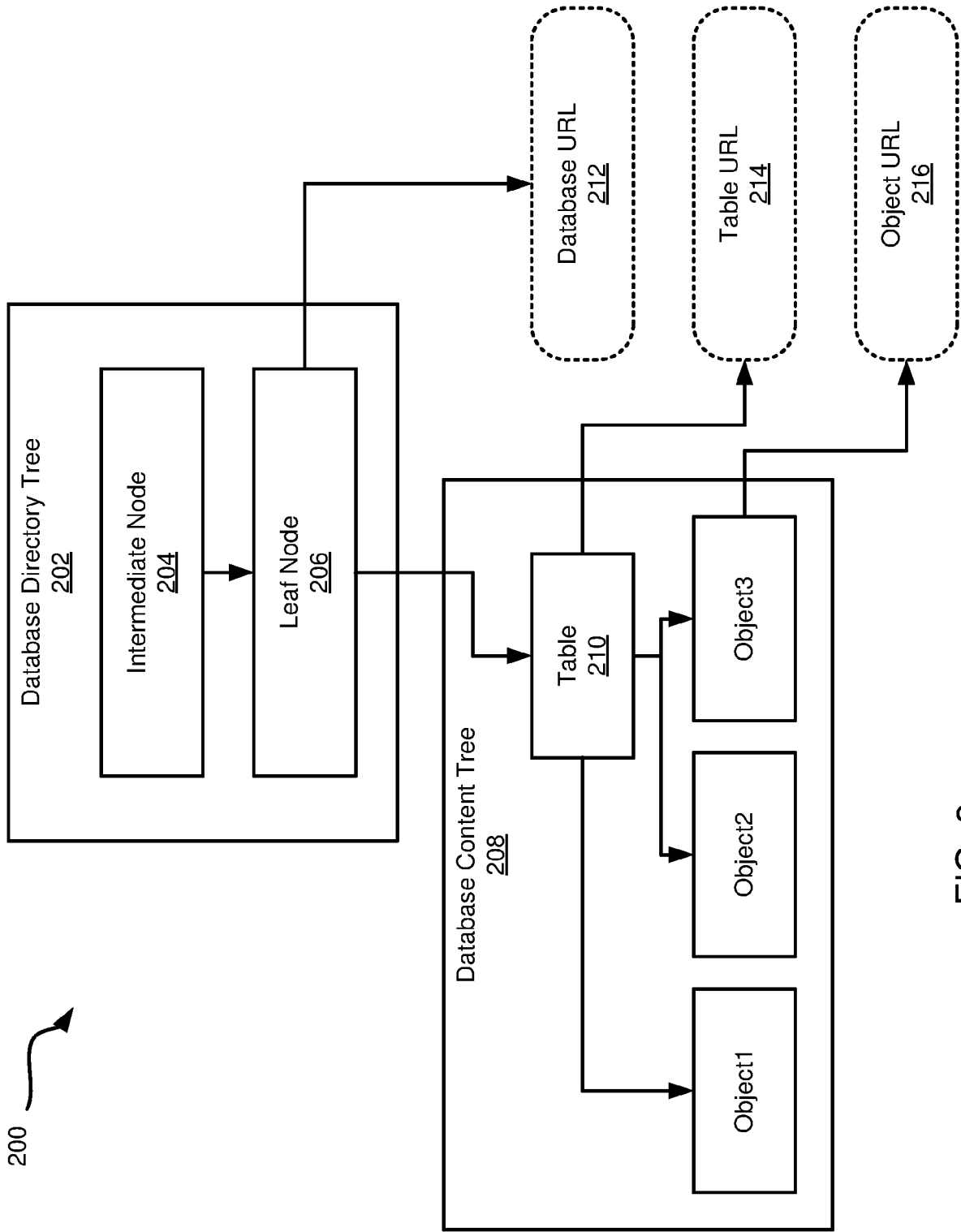

FIG. 2

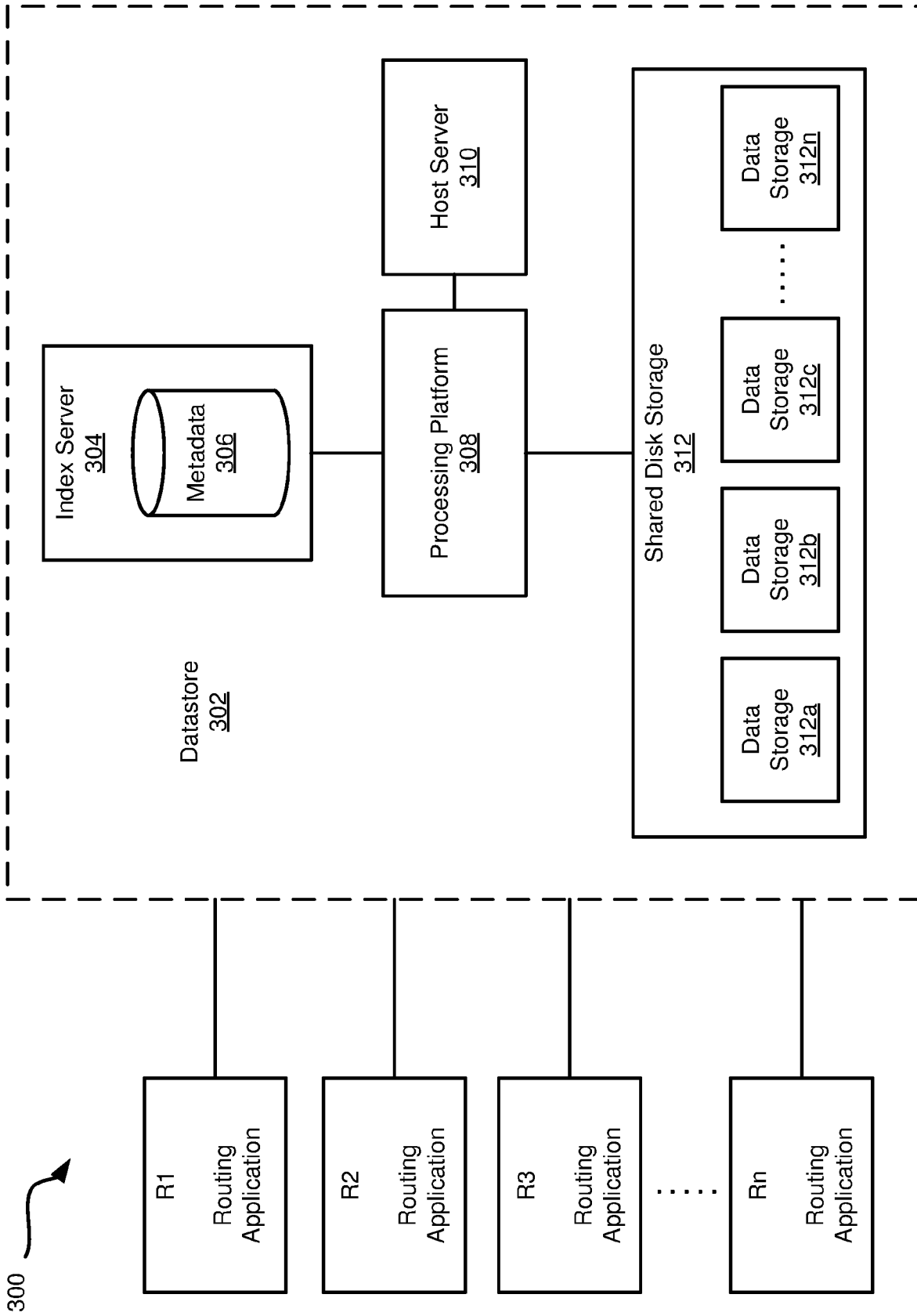

FIG. 3

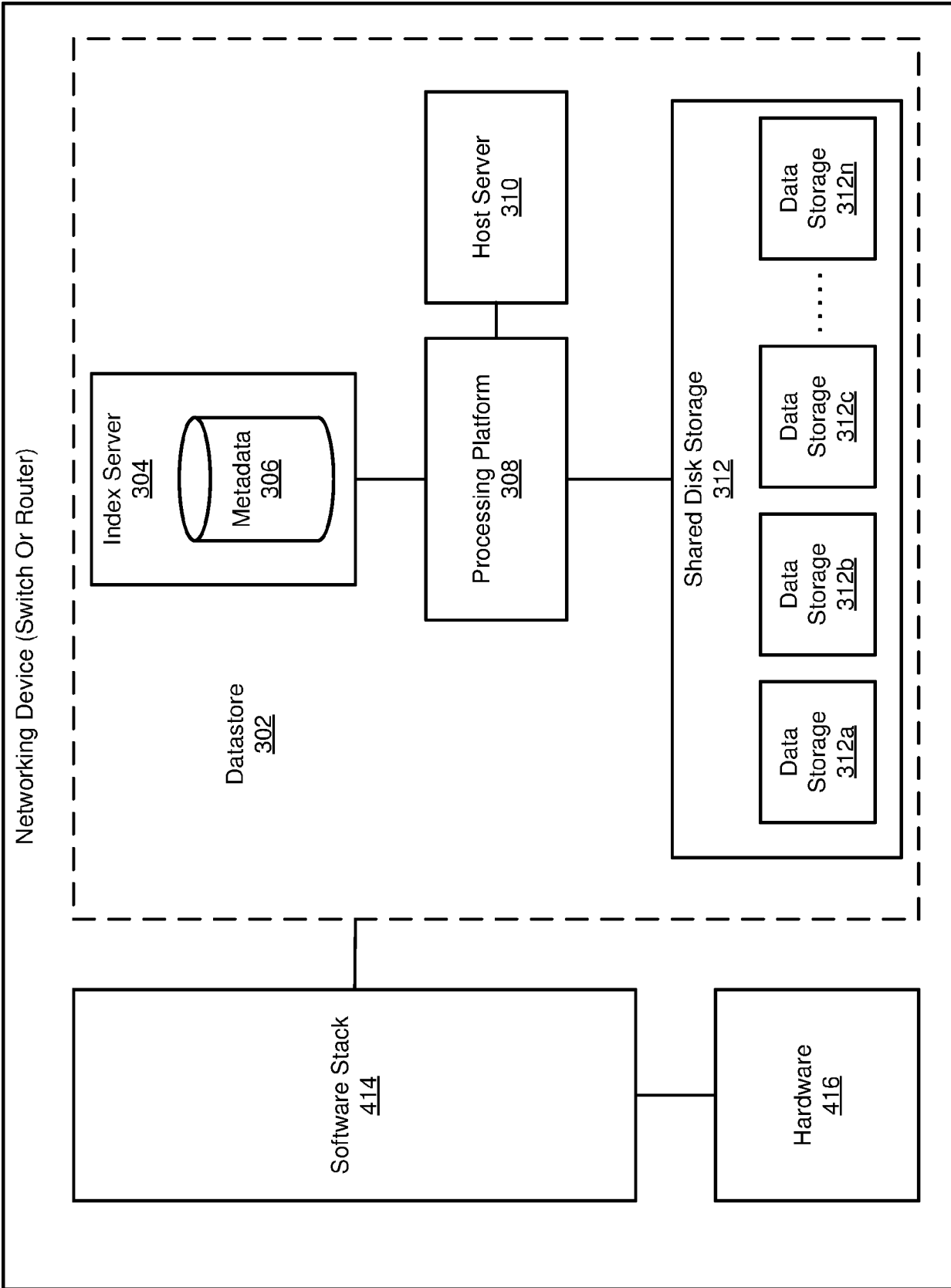

FIG. 4

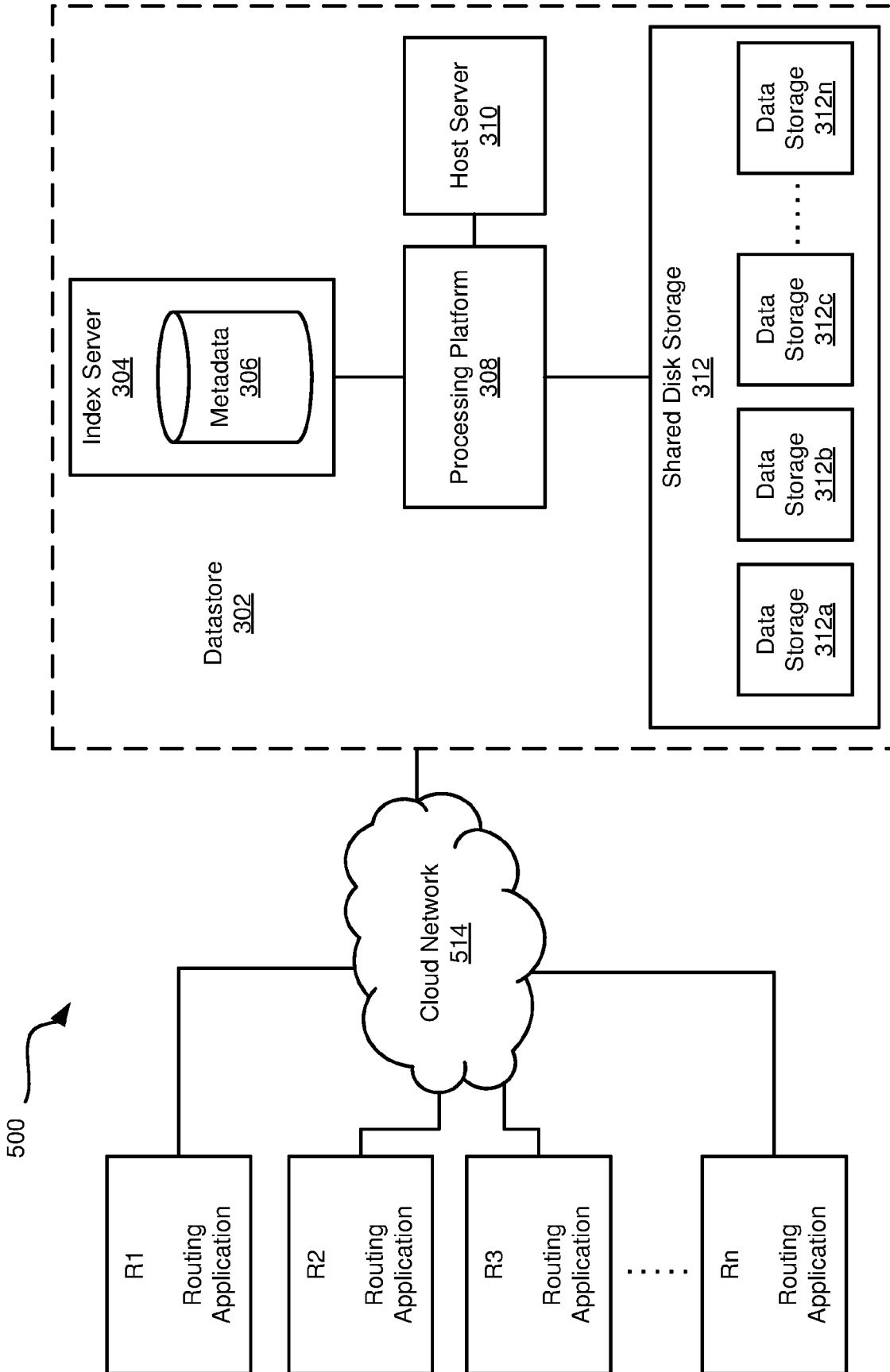

FIG. 5

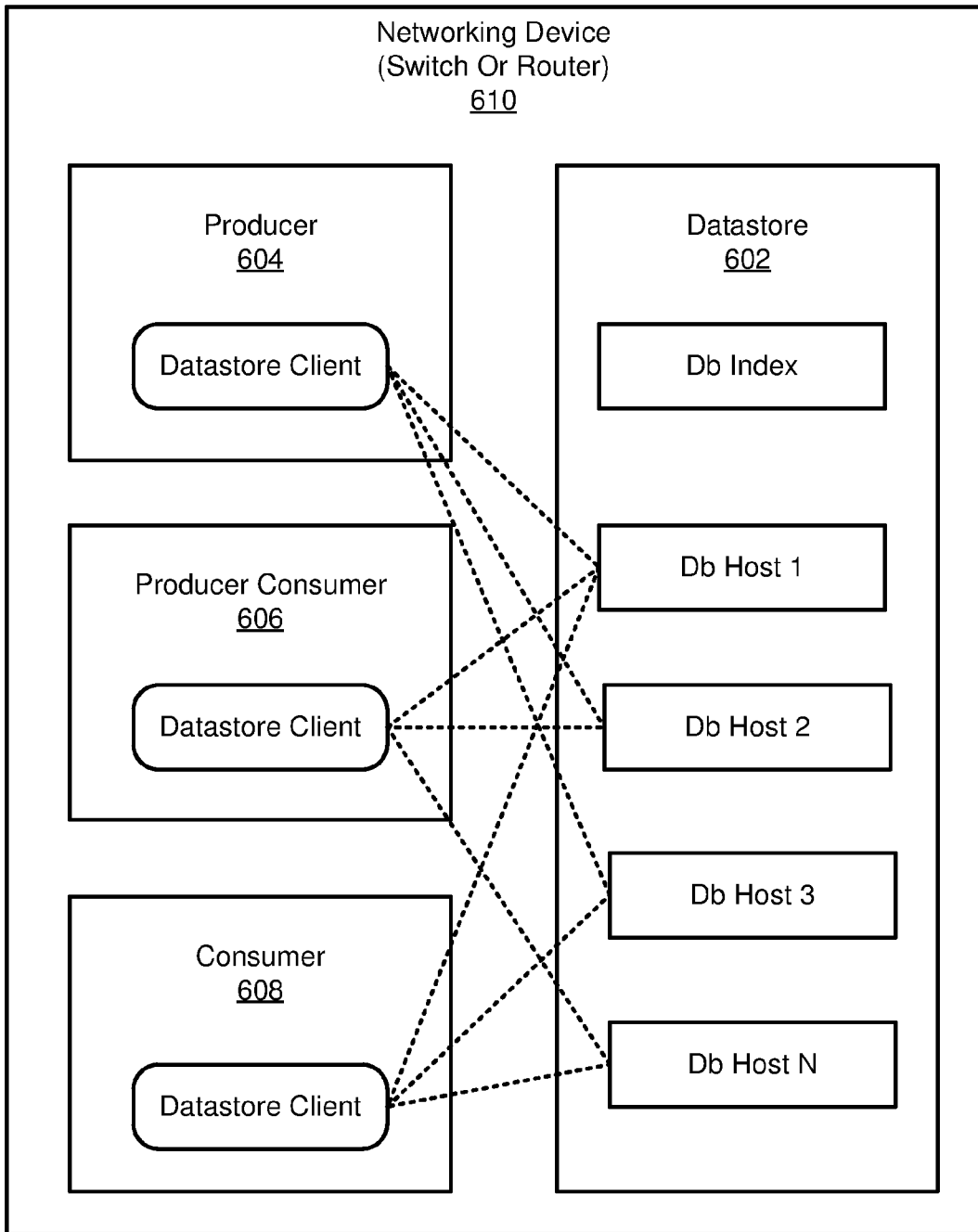

FIG. 6

FIG. 7

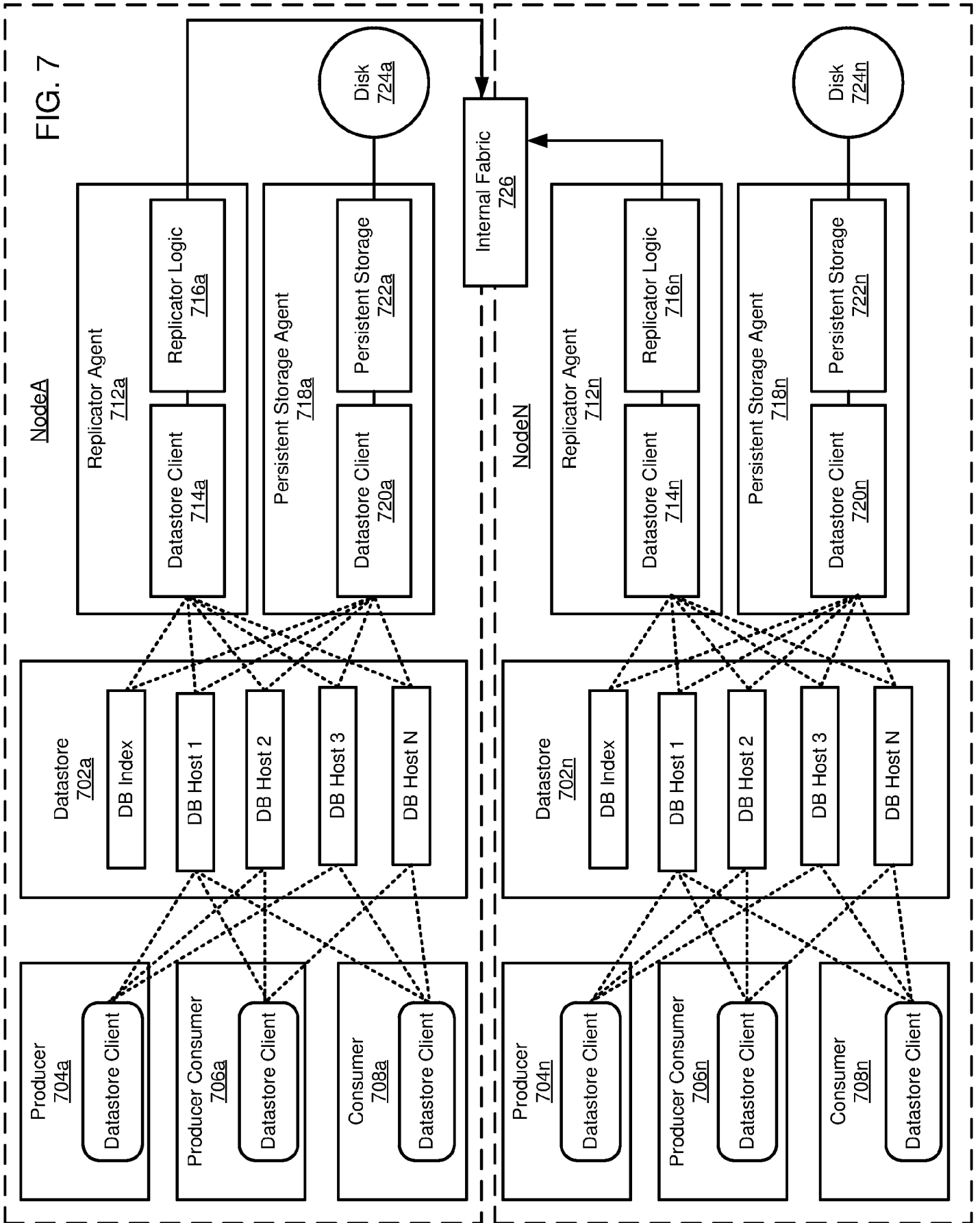

FIG. 8

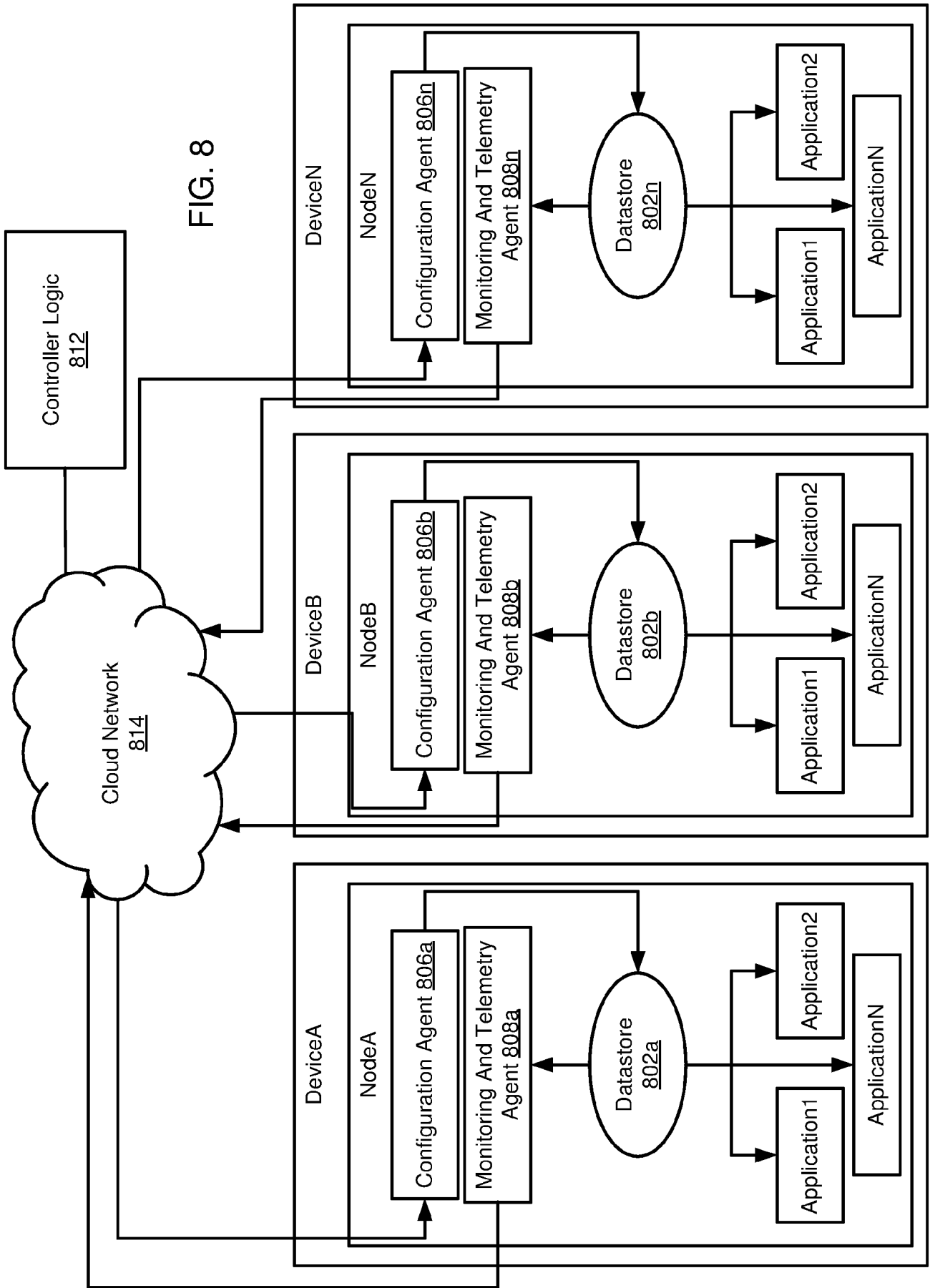
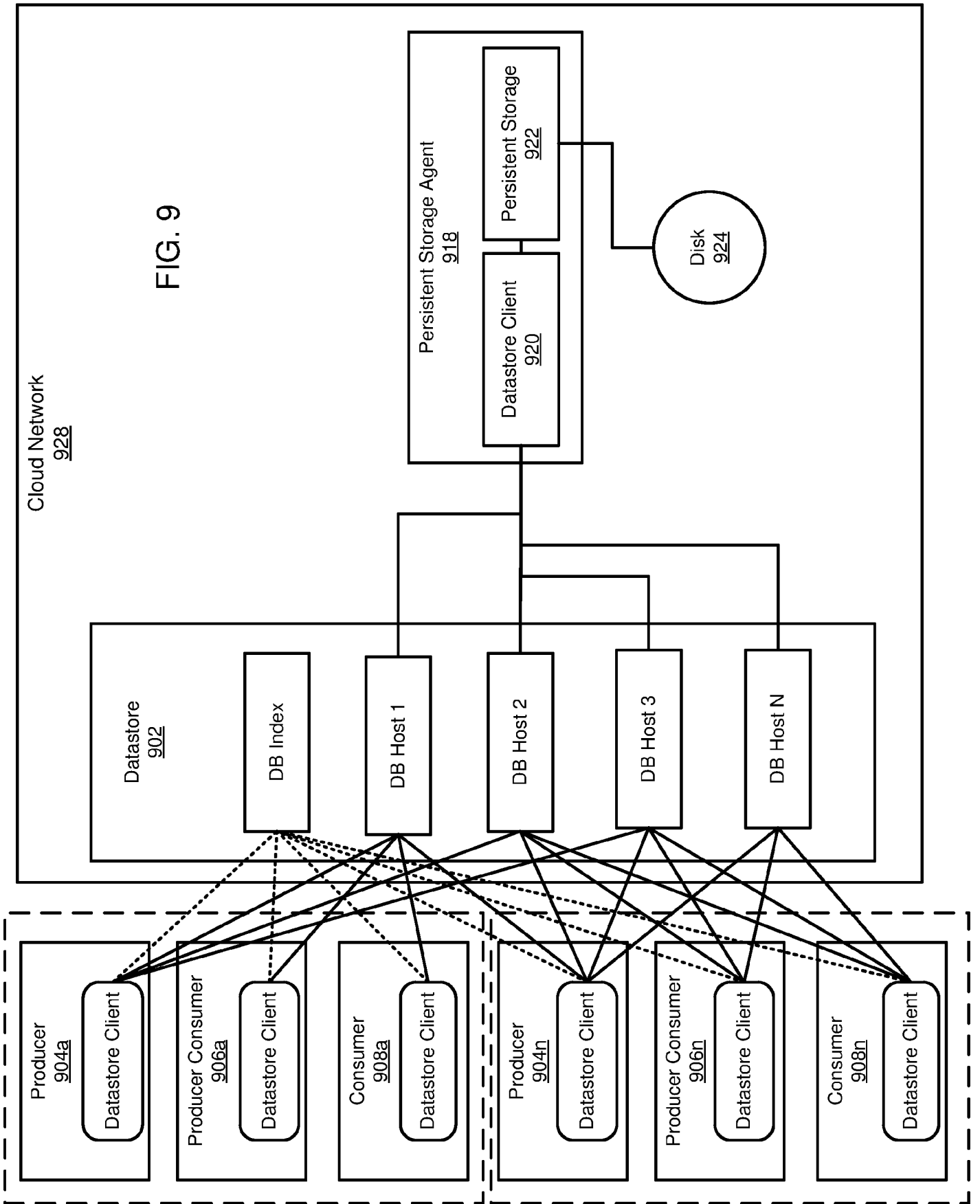

FIG. 9



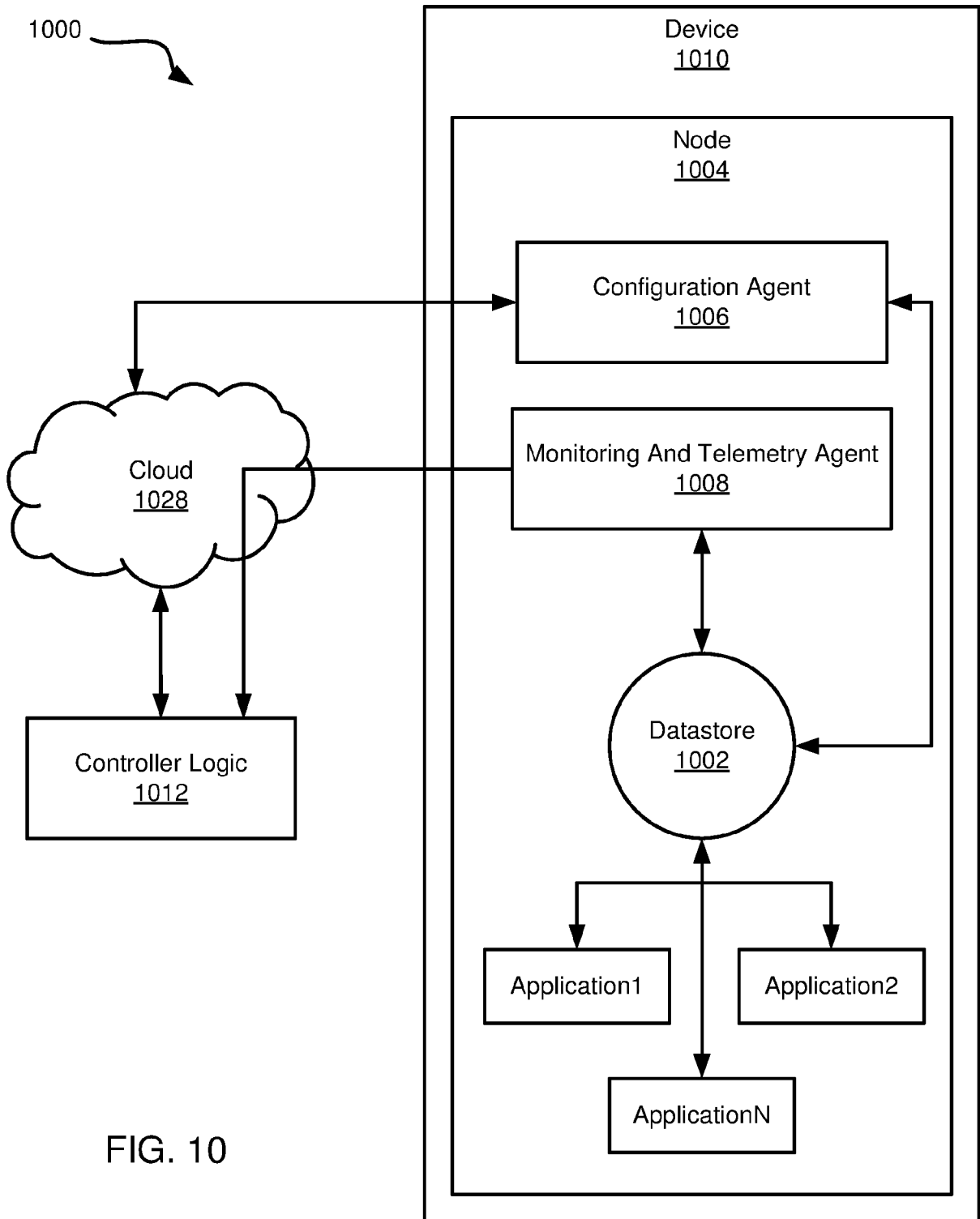
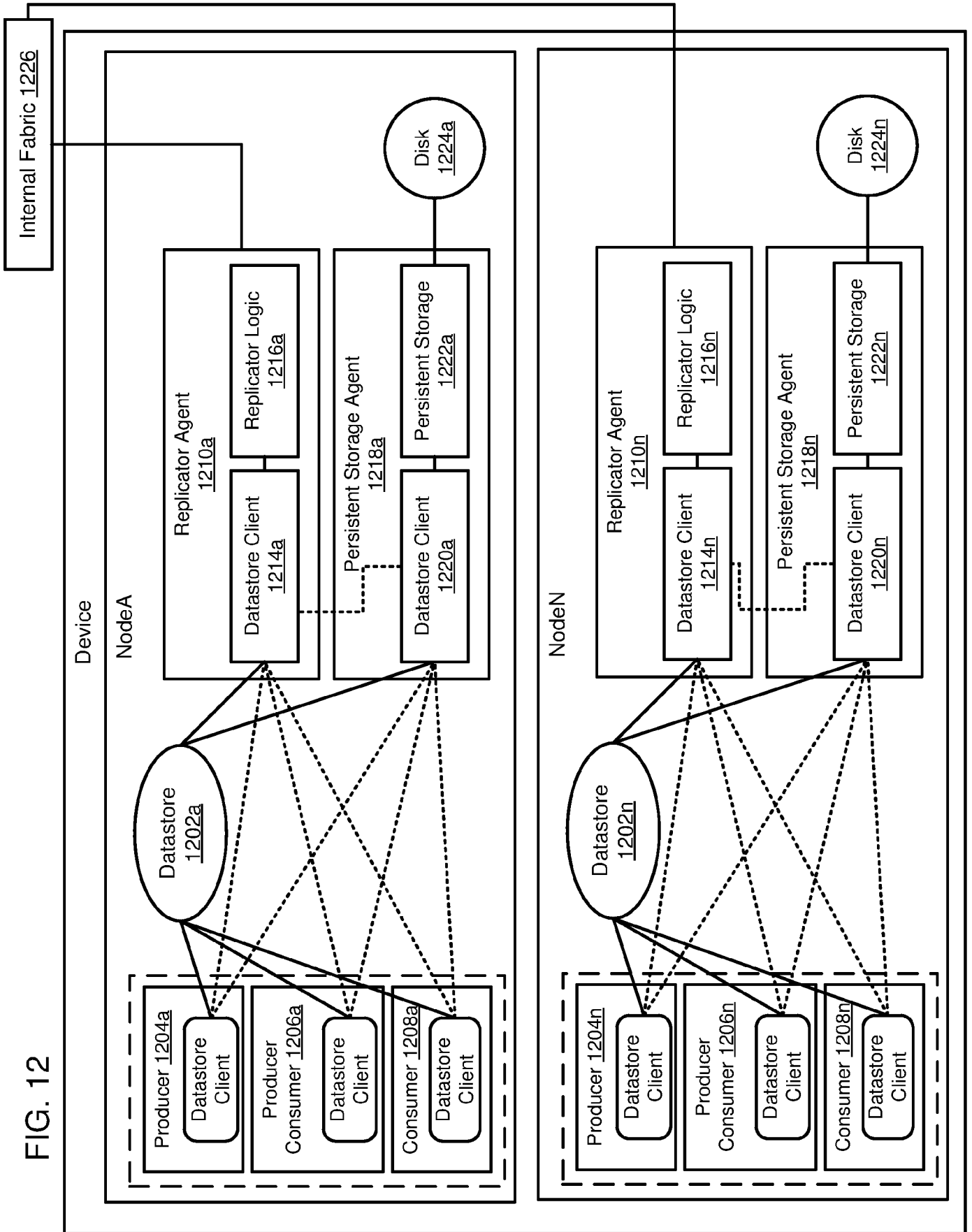

FIG. 10



FIG. 12



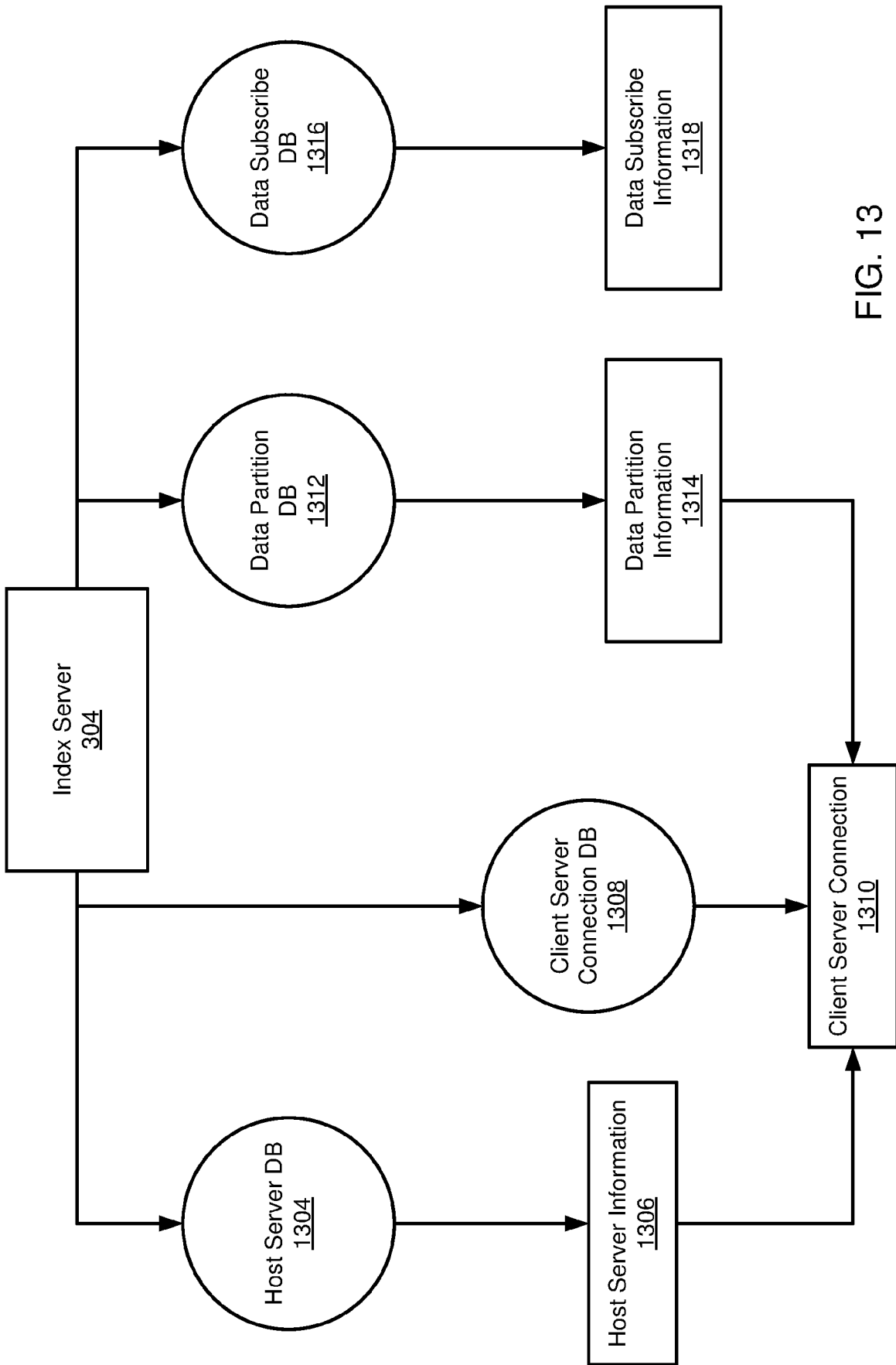

FIG. 13

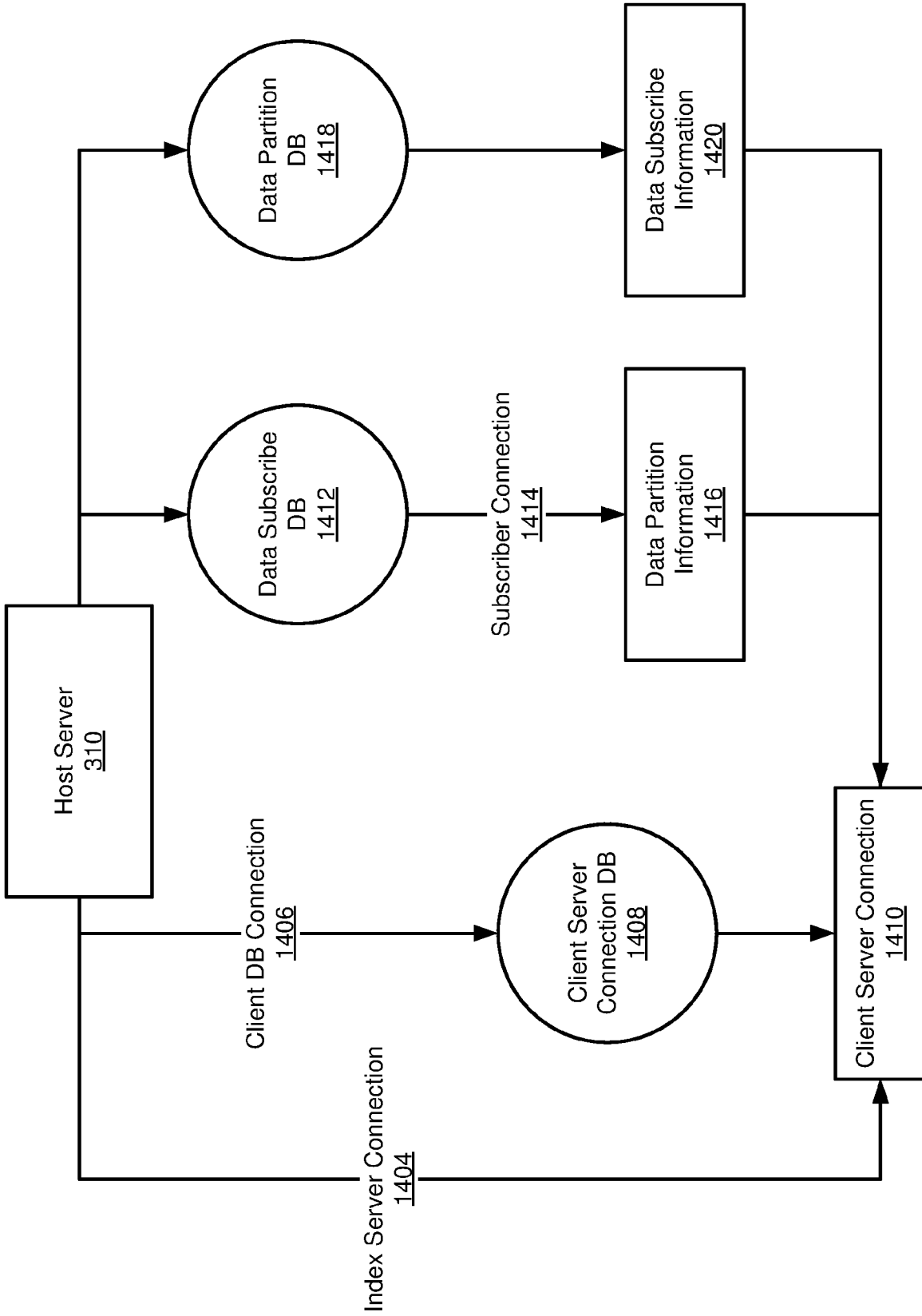

FIG. 14

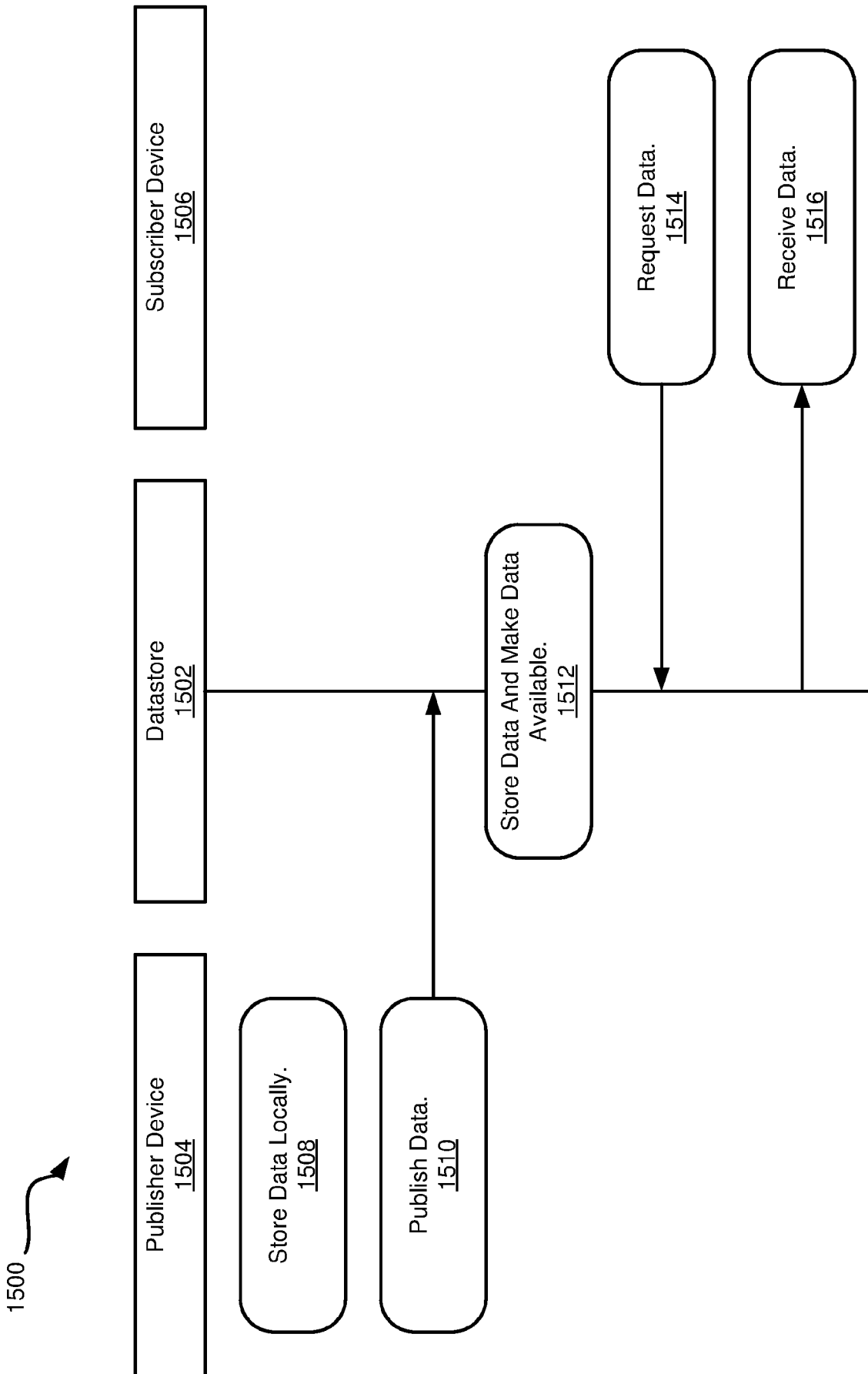

FIG. 15

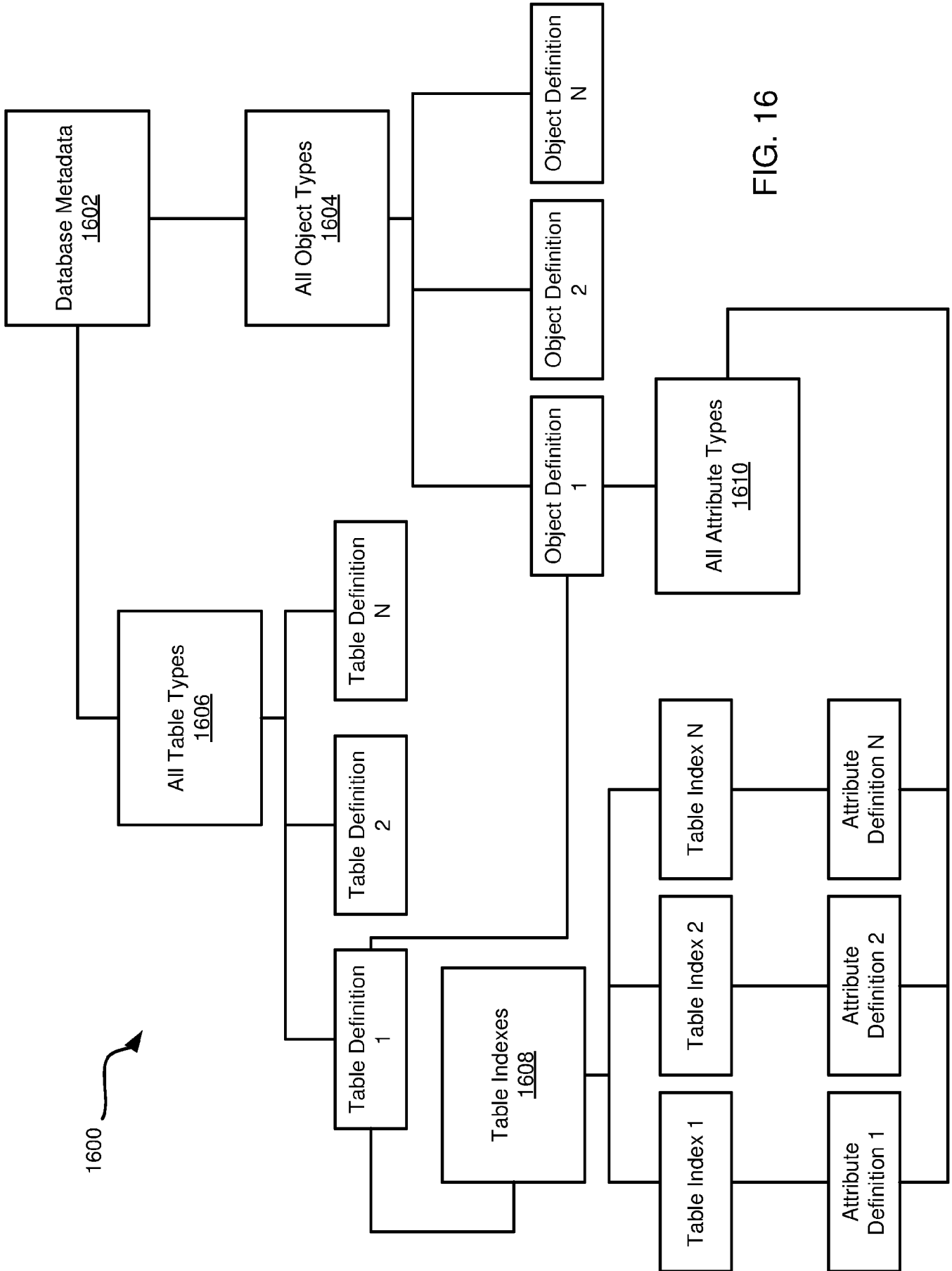



FIG. 16

1700 

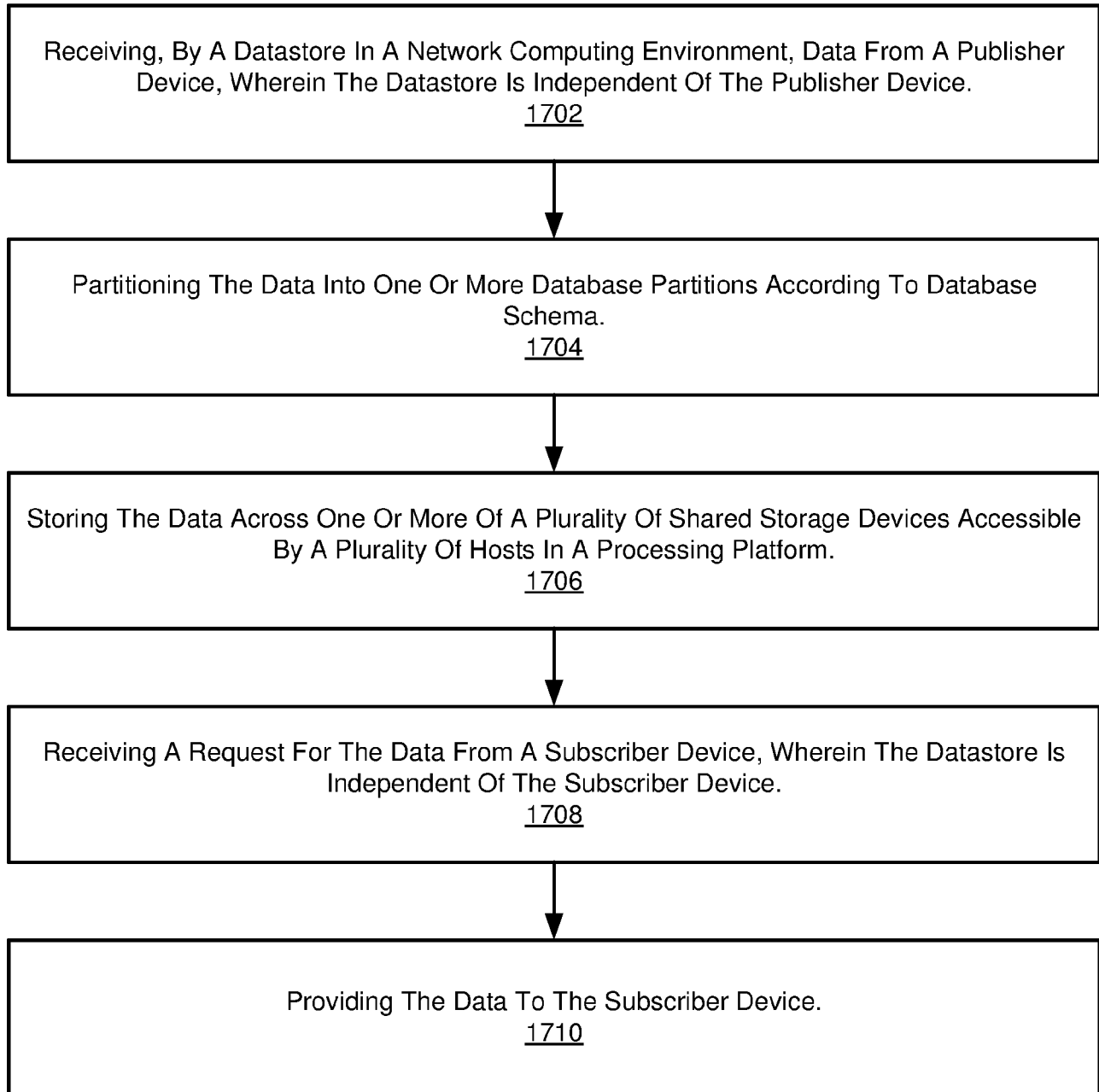



FIG. 17

1800 

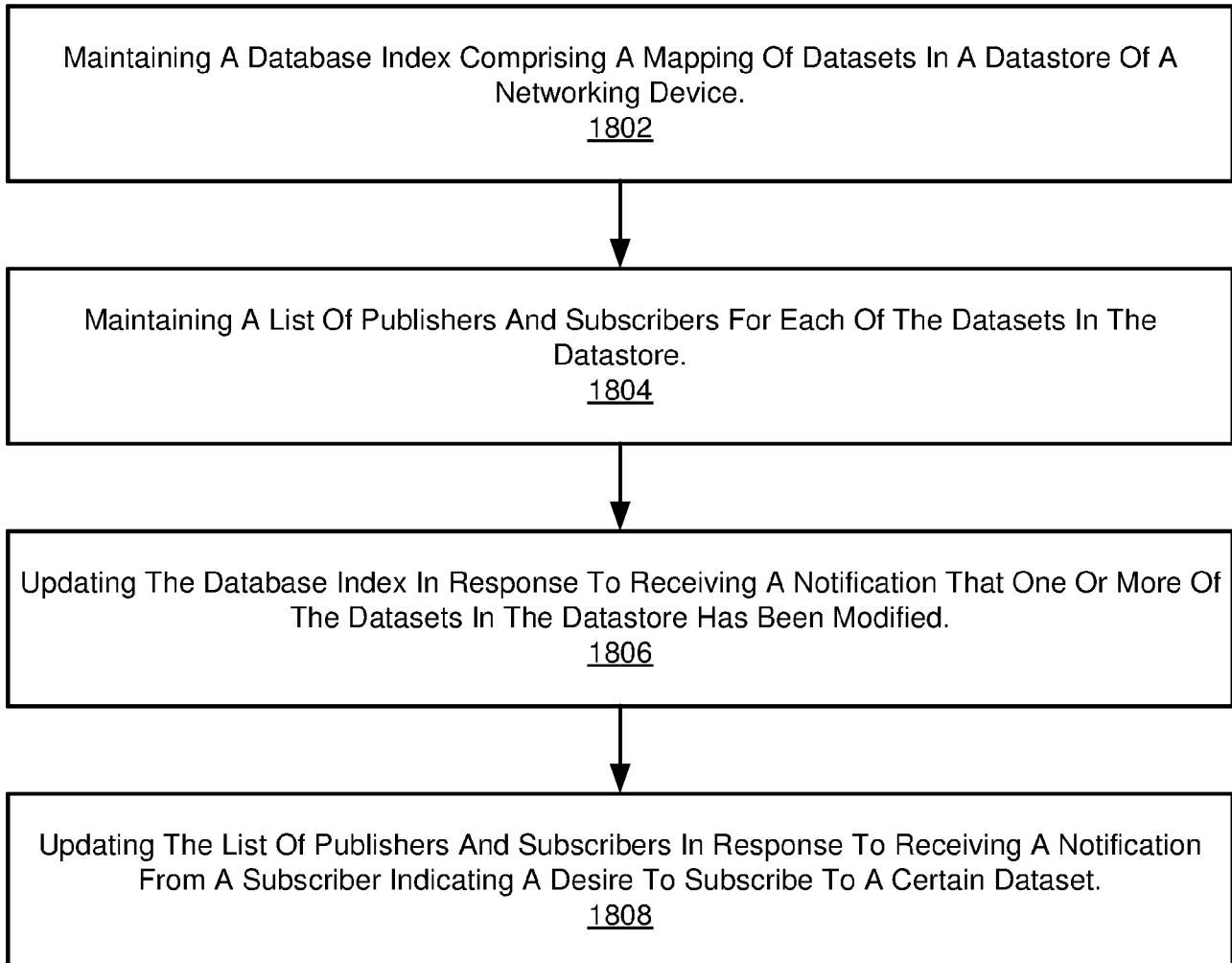

FIG. 18

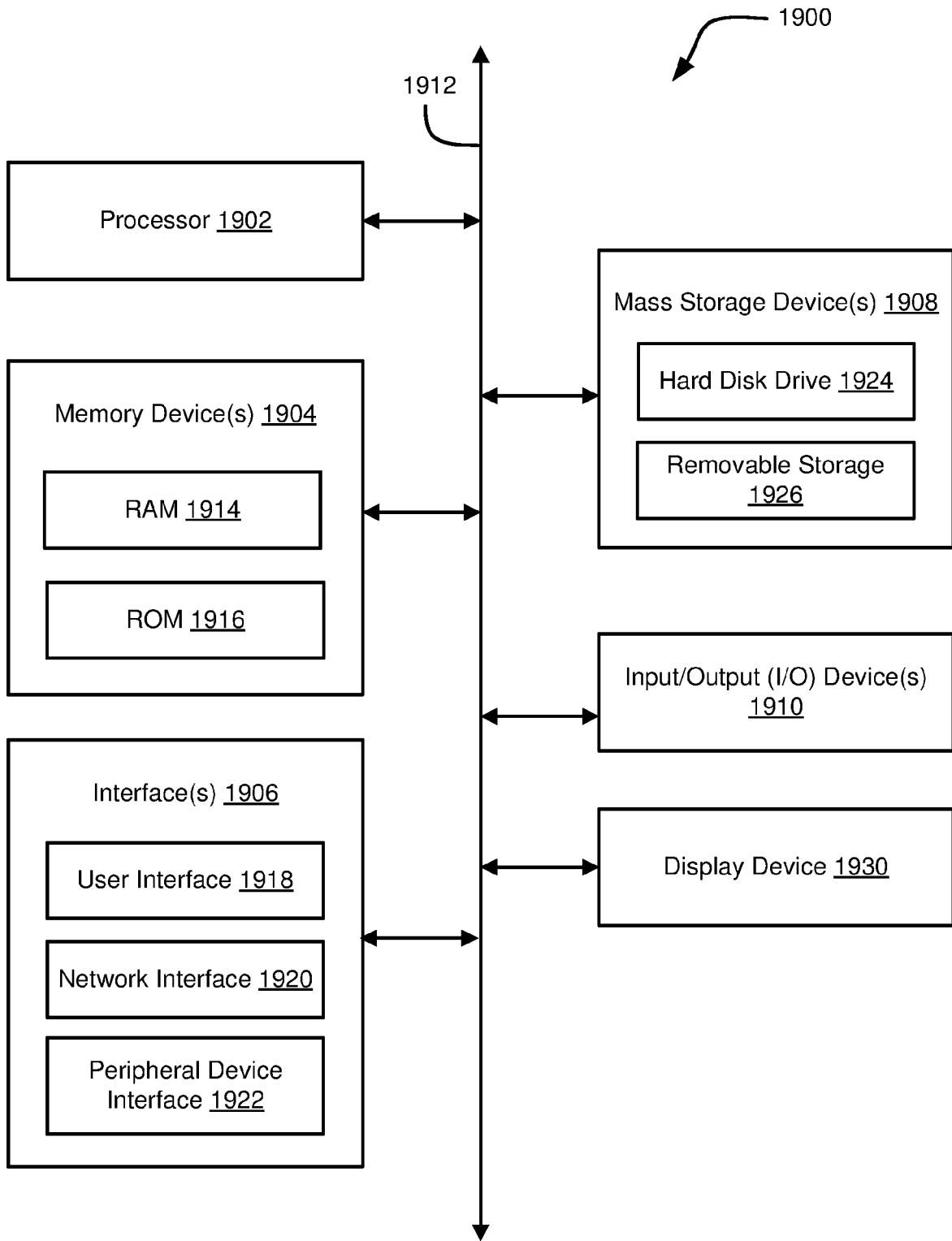

FIG. 19

FIG. 11

