

Nov. 30 1943.

S. GASPER

2,335,503

SCRUBBING BRUSH

Filed April 2, 1941

2 Sheets-Sheet 1

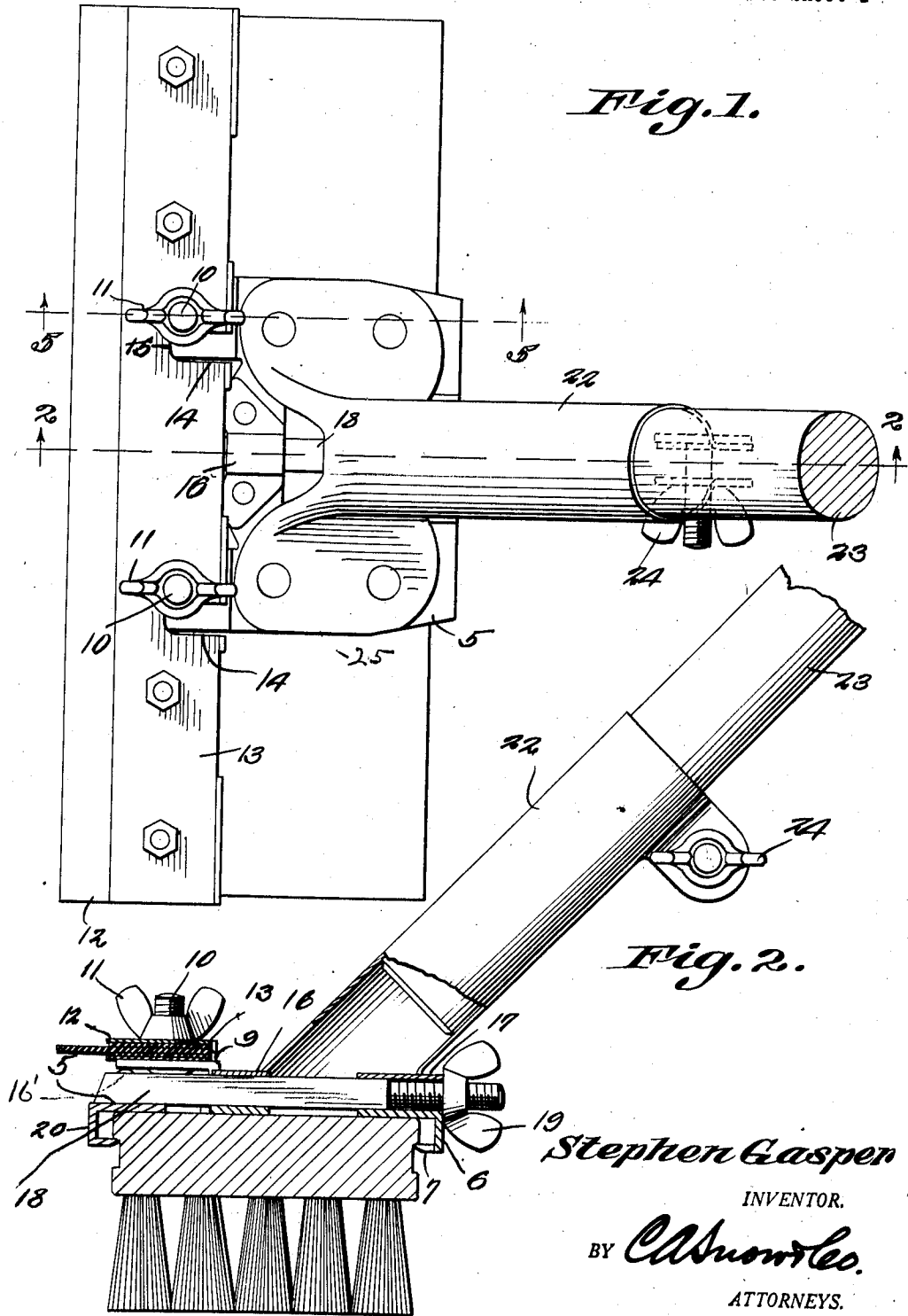

Fig. 1.

Fig. 2.

Stephen Gasper
INVENTOR.
BY *W. W. Lewis*
ATTORNEYS.

Nov. 30 1943.

S. GASPER

2,335,503

SCRUBBING BRUSH

Filed April 2, 1941

2 Sheets-Sheet 2

Fig. 3.

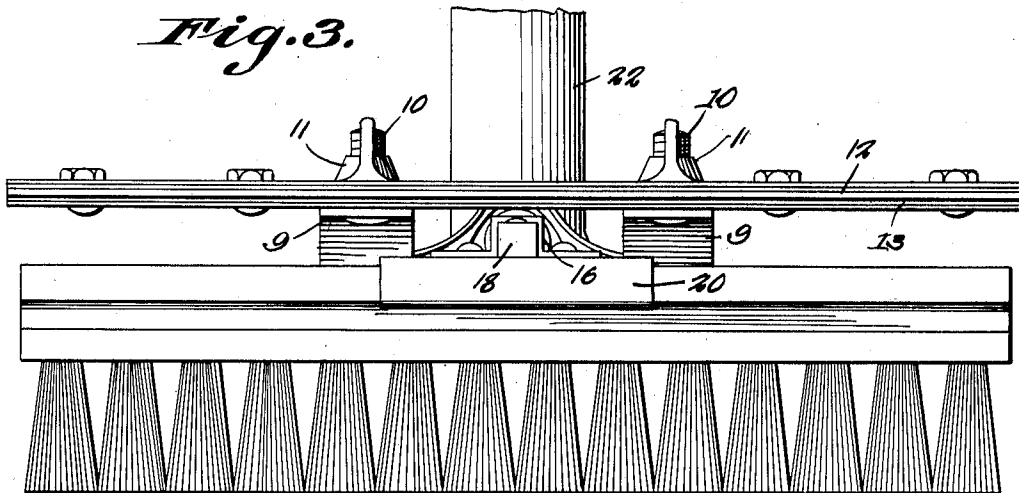

Fig. 4.

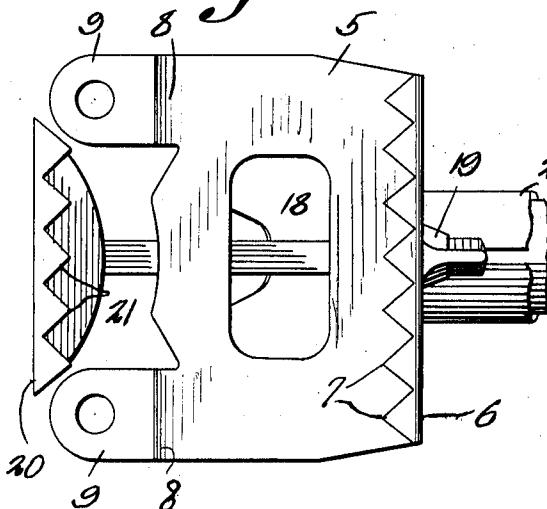

Fig. 5.

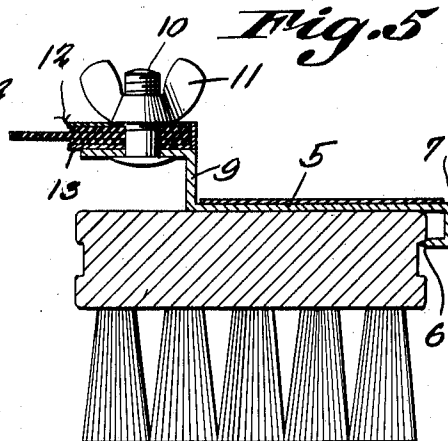
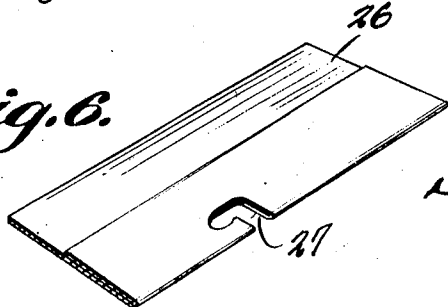

Fig. 6.



Stephen Gasper

INVENTOR.

BY *Edwards*

ATTORNEYS.

UNITED STATES PATENT OFFICE

2,335,503

SCRUBBING BRUSH

Stephen Gasper, Gary, Ind.

Application April 2, 1941, Serial No. 386,548

1 Claim. (Cl. 15—146)

This invention relates to brush and mop construction, the primary object of the invention being to provide a scrubbing brush including a handle provided with a clamping head which may be readily and easily clamped to the brush, mop or polishing head used therewith, in such a way that the brush, mop or polishing head will be securely held in position while in operation.

An important object of the invention is to provide a clamping head embodying a stationary clamping section and a movable or adjustable section adapted to automatically adjust itself for gripping brush, mop or polishing heads of various widths and shapes.

A further object of the invention is to provide a clamping head having means for removably securing a drier or scraping blade thereto, so that the device may be readily used for removing water or foreign matter from the surface under treatment

With the foregoing and other objects in view, which will appear as the description proceeds, the invention resides in the combination and arrangement of parts and in the details of construction hereinafter described and claimed, it being understood that changes in the precise embodiment of the invention herein described, may be made within the scope of what is claimed, without departing from the spirit of the invention.

Referring to the drawings:

Figure 1 is a plan view of a mop handle and clamping means constructed in accordance with the invention.

Figure 2 is a sectional view taken on line 2—2 of Figure 1.

Figure 3 is a front elevational view of the mop.

Figure 4 is a bottom plan view of the clamping head.

Figure 5 is a sectional view taken substantially on line 5—5 of Figure 1.

Figure 6 is a fragmental perspective view illustrating the scraping blade which may be positioned on the clamping head, in lieu of the wiping blade.

Referring to the drawings in detail, the brush clamping head comprises a substantially wide plate 5, the rear edge of the plate 5 being extended downwardly and inwardly as at 6, portions of the inwardly extended edge being cut-away providing teeth 7.

The front edge of the plate 5 is cut-away providing forwardly extended arms 8 that are formed with offset portions 9. Bolts 10 extend

upwardly from the arms 8, and are supplied with winged nuts 11 by means of which a wiping or scraping blade may be secured to the clamp head.

As shown by Figure 5 of the drawings, a wiper blade is indicated by the reference character 12, the wiper blade embodying a length of rubber held between the metal plates 13. The metal plates 13 are formed with slots 14 that terminate in the laterally extended portions 15, affording means whereby the wiping blade may be readily positioned on the clamping head, to insure against movement of the blade with respect to the clamping head, when in use.

Secured on the upper surface of the plate 5, and disposed intermediate the side edges thereof, is a bearing member 16 that aligns with the bearing member 17 arranged on the upper surface of the plate and disposed adjacent to the rear edge of the plate. These bearing members are rectangular in formation, to receive the rectangular bar 18 that has its rear end threaded to receive the winged nut 19.

Pivotally connected with the front end of the bar 18 by means of the bolt 16', is a jaw 20 that has inwardly extended teeth 21 designed to cooperate with the teeth 7, in gripping the head of a brush, securing the clamping head to brush.

Rising from the upper surface of the plate 5, and disposed at an oblique angle with respect to the plate, is the socket member 22, which is longitudinally split, and is clamped around the handle, which in the present showing is indicated at 23, by means of the winged nut 24.

As clearly shown by Figure 1 of the drawings, the socket member is provided with laterally extended flanges 25 that are bolted to the plate 5, in such a way that the plate 5 will be held in a true horizontal position, against rocking when pressure is applied to the brush handle in using the brush.

From the foregoing it will be seen that due to the construction shown and described, I have provided a handle clamping head which may be readily and securely positioned over the head of a brush to clamp the handle to the brush. Because the jaw 20 is pivotally mounted on the forward end of the bar 18, it will be seen that the jaw may readily move to compensate for irregularities in the brush head to which the clamp is secured.

It may be desirable to use a scraper, such as shown by Figure 6 of the drawings, in lieu of the wiping blade. The scraper embodies a metallic section 26, a portion of the blade being

bent upon itself reenforcing the blade at the point of contact with the clamping head.

Openings indicated at 27 are formed in the scraping blade, and are adapted to accommodate the bolts 10, should it be desired to use a scraping blade in connection with the brush. 5

What is claimed is:

A handle attachment for scrubbing brush heads, comprising a wide plate, a flange formed along one edge of the plate, said flange being extended downwardly and forwardly, teeth 10 formed throughout the length of the forward

edge of the flange, rectangular bearings on the upper surface of the plate and disposed intermediate the ends thereof, a rectangular threaded bar fitted within said bearings, a wide jaw secured to one end of the bar, inwardly extended teeth formed along one edge of the jaw secured to the bar, and adapted to cooperate with the teeth on the plate in gripping a brush head, and a wing nut operating on the threaded bar and adapted to move the teeth of the jaw and plate toward each other.

STEPHEN GASPER.