

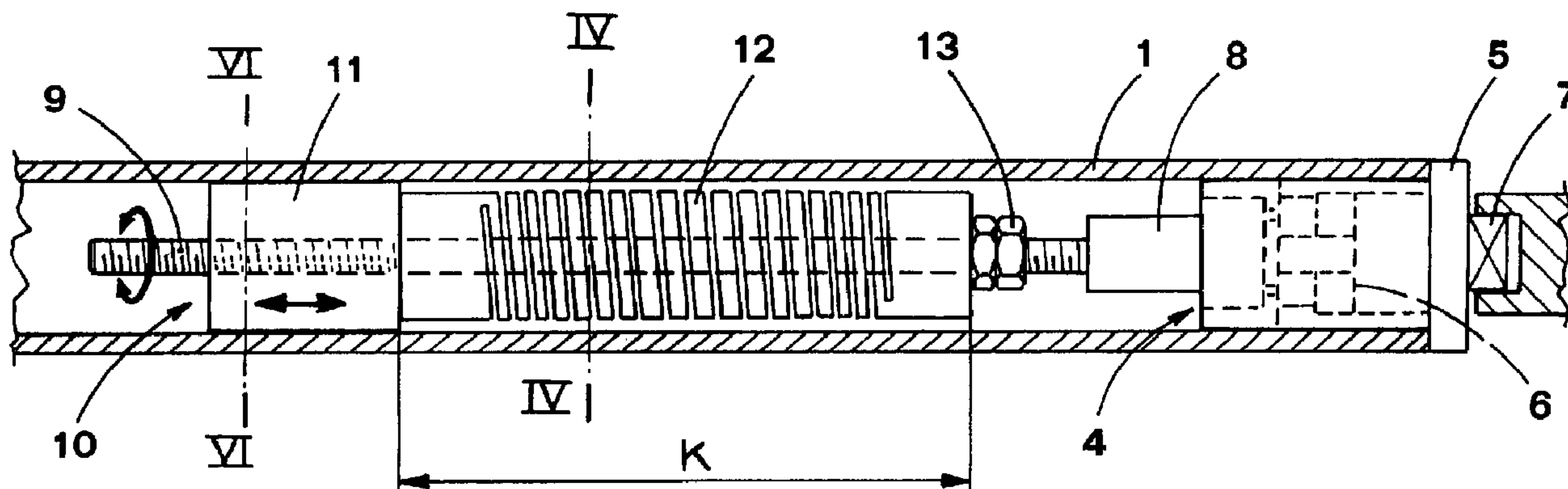

(86) Date de dépôt PCT/PCT Filing Date: 2002/06/20  
 (87) Date publication PCT/PCT Publication Date: 2003/01/03  
 (45) Date de délivrance/Issue Date: 2009/10/20  
 (85) Entrée phase nationale/National Entry: 2003/12/19  
 (86) N° demande PCT/PCT Application No.: IB 2002/002284  
 (87) N° publication PCT/PCT Publication No.: 2003/001018  
 (30) Priorité/Priority: 2001/06/21 (IT BO01A000396)

(51) Cl.Int./Int.Cl. *E06B 9/44* (2006.01),  
*E06B 9/60* (2006.01), *E06B 9/62* (2006.01)  
 (72) Inventeur/Inventor:  
MINDER, CARL EMIL FELIX, IT  
 (73) Propriétaire/Owner:  
SILENT GLISS ITALIA S.R.L., IT  
 (74) Agent: MARKS & CLERK

(54) Titre : DISPOSITIF DE FRICTION POUR RIDEAUX A ENROULEMENT ET ASSIMILES  
 (54) Title: A FRICTION DEVICE FOR ROLL-UP CURTAINS AND THE LIKE



(57) Abrégé/Abstract:

A friction device (10), applied to roll-up curtains and the like, includes a tubular roller (1), on which the curtain (2) rolls up, and which is rotatably carried on a horizontal axis. The friction device (10) includes a threaded shaft (9), situated axially inside the roller (1) and connected to the roller (1) by interposition of an angular speed reducer group (4). A body (11), mounted sliding axially inside the roller (1), is screw-coupled with the threaded shaft (9), so as to translate axially due to the shaft (9) rotation during unrolling or rolling up of the curtain (2) on the roller (1). One or more elastic members (12), subjected to pressure or counter-thrust, are compressed, on opposite ends, between abutment means (13) and a surface of the body 11 and a surface of the body (11), to determine a friction effect, which varies as a function of the rotation direction of the roller (1).

## (12) INTERNATIONAL APPLICATION PUBLISHED UNDER THE PATENT COOPERATION TREATY (PCT)

(19) World Intellectual Property Organization  
International Bureau



(43) International Publication Date  
3 January 2003 (03.01.2003)

PCT

(10) International Publication Number  
WO 03/001018 A1

(51) International Patent Classification<sup>7</sup>: E06B 9/44,  
9/60, 9/62

(21) International Application Number: PCT/IB02/02284

(22) International Filing Date: 20 June 2002 (20.06.2002)

(25) Filing Language: English

(26) Publication Language: English

(30) Priority Data:  
BO01A000396 21 June 2001 (21.06.2001) IT

(71) Applicant and

(72) Inventor: MINDER, Carl, Emil, Felix [IT/IT]; Via Disciplini 9, I-20123 Milano (IT).

(74) Agent: DALL'OLIO, Giancarlo; Invention S.a.s., Via delle Armi 1, I-40137 Bologna (IT).

(81) Designated States (national): AE, AG, AL, AM, AT, AU, AZ, BA, BB, BG, BR, BY, BZ, CA, CH, CN, CO, CR, CU,

CZ, DE, DK, DM, DZ, EC, EE, ES, FI, GB, GD, GE, GH, GM, HR, HU, ID, IL, IN, IS, JP, KE, KG, KP, KR, KZ, LC, LK, LR, LS, LT, LU, LV, MA, MD, MG, MK, MN, MW, MX, MZ, NO, NZ, OM, PH, PL, PT, RO, RU, SD, SE, SG, SI, SK, SL, TJ, TM, TN, TR, TT, TZ, UA, UG, US, UZ, VN, YU, ZA, ZM, ZW.

(84) Designated States (regional): ARIPO patent (GH, GM, KE, LS, MW, MZ, SD, SL, SZ, TZ, UG, ZM, ZW), Eurasian patent (AM, AZ, BY, KG, KZ, MD, RU, TJ, TM), European patent (AT, BE, CH, CY, DE, DK, ES, FI, FR, GB, GR, IE, IT, LU, MC, NL, PT, SE, TR), OAPI patent (BF, BJ, CF, CG, CI, CM, GA, GN, GQ, GW, ML, MR, NE, SN, TD, TG).

**Published:**

— with international search report

For two-letter codes and other abbreviations, refer to the "Guidance Notes on Codes and Abbreviations" appearing at the beginning of each regular issue of the PCT Gazette.

(54) Title: A FRICTION DEVICE FOR ROLL-UP CURTAINS AND THE LIKE

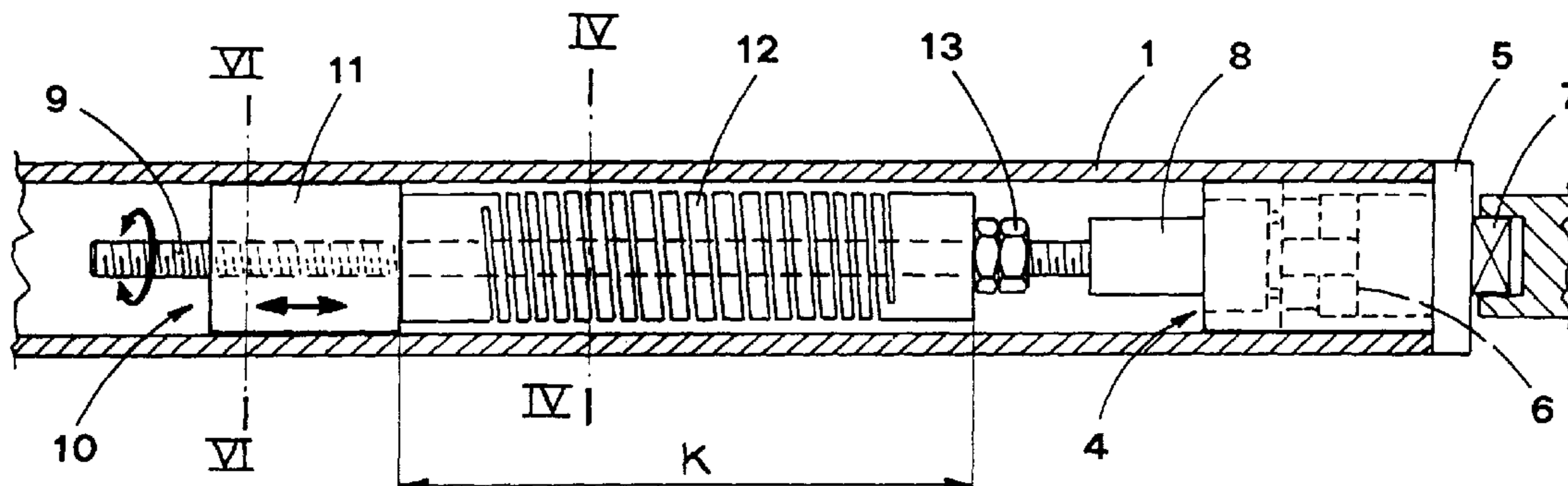

(57) Abstract: A friction device (10), applied to roll-up curtains and the like, includes a tubular roller (1), on which the curtain (2) rolls up, and which is rotatably carried on a horizontal axis. The friction device (10) includes a threaded shaft (9), situated axially inside the roller (1) and connected to the roller (1) by interposition of an angular speed reducer group (4). A body (11), mounted sliding axially inside the roller (1), is screw-coupled with the threaded shaft (9), so as to translate axially due to the shaft (9) rotation during unrolling or rolling up of the curtain (2) on the roller (1). One or more elastic members (12), subjected to pressure or counter-thrust, are compressed, on opposite ends, between abutment means (13) and a surface of the body (11) and a surface of the roller (1), to determine a friction effect, which varies as a function of the rotation direction of the roller (1).

WO 03/001018 A1

- 1 -

**A FRICTION DEVICE FOR ROLL-UP CURTAINS AND THE LIKE****Field of the Invention**

The present invention relates to the technical field  
5 concerning roll-up curtains to be applied to windows and  
the like, in order to shade, protect or decorate.

**Background of the Invention**

The roll-up curtains are usually rolled up on a roller,  
10 which is rotatably carried on a horizontal axis inside a  
suitable casing situated at top of the window.

The axial rotation of the roller determines rolling and  
unrolling of the curtain.

According to a known solution, the roll-up curtains are  
15 operated manually during both rolling and unrolling.

For this purpose, the head of the roller has a pulley  
featuring a groove, which engages with an operating  
chain.

One of the drawbacks of this type of roll-up curtains is  
20 the risk of falling during unrolling, i.e. a too quick  
descent of the curtain can occur due to its weight.

It is to be particularly noted that the falling speed of  
the curtain increases rapidly during unrolling.

Obviously, this drawback is felt stronger in the special  
25 case of relatively heavy curtains.

According to another solution, the roll-up curtains are  
equipped with a safety device with elastic means situated  
inside the roller and fastened thereto to facilitate the  
curtain rolling up.

- 2 -

The curtain unrolling rotation, carried out by acting directly thereon, determines torsion of the elastic means, so that the consequent elastic reaction can be used for rolling up again the curtain.

5 The elastic means are fastened, at one end, to the roller and at the other end, to a stationary support structure, so that they are stressed in accordance with the curtain unrolling.

To avoid undulations, possible in particular conditions,  
10 of the elastic means, these elastic means are fastened at one end to a movable element, which moves axially inside the roller, and are driven into rotation therealong.

For instance, the European Patent EP 0900314 describes improved elastic means, which return a gradual elastic  
15 reaction during the curtain rolling up.

The improved elastic means include a plurality of helical springs aimed at rolling the curtain up on a respective roller.

The coil springs are fastened to a common support, keyed  
20 to the roller, and to respective support and constraint elements, geometrically fastened to the above roller.

The above described support devices fulfill also the additional task of contrasting the curtain descent, but obviously, they themselves cannot solve the drawback of a  
25 curtain possible fall during unrolling.

#### Summary of the Invention

The object of the present invention is to propose a friction device which avoids possible fall of the curtain  
30 during unrolling, independently from the design and dimensions of the curtain.

- 3 -

Another object of the present invention is to propose a friction device capable of braking the curtain fall during its unrolling.

5 A further object of the present invention is to propose a friction device, which is very functional and simple to manufacture, as well as to use, and which is versatile and can be used with different types of roll-up curtains.

10 A still further object of the present invention is to propose a device which is associated to a curtain operated by a chain and which is not damaged if the curtain is operated directly manually.

15 A yet further object of the present invention is to propose a universal device, i.e. a device which can be connected, during the installation or in any subsequent moment, to any end of the curtain, so as to be connected to the operating chain situated either on the right or on the left of the latter.

20 A still further object of the present invention is to propose a device which not only achieves the previous objects, but is also cheap and includes components such as to render the assembly easy.

A yet further object of the present invention is to propose a device which can be assembled in one piece, so that it can easily be mounted in a related curtain.

25 A still further object of the present invention is to propose a device which, when associated to the curtain equipped with support elastic means, balances in a simple way the operation of the curtain during the unrolling and rolling up thereof.

30 The above mentioned objects are obtained in accordance with the contents of the claims, by means of a friction

- 4 -

device for roll-up curtains and the like, including a tubular roller, on which the curtain rolls up, and which is rotatably carried on a horizontal axis, characterized in that it includes a threaded shaft, situated axially  
5 inside said roller and connected to the roller by interposition of an angular speed reducer group; a body mounted sliding axially inside said roller and screw-coupled with said threaded shaft, so as to translate axially due to the shaft rotation during unrolling or  
10 rolling up of said curtain on said roller; at least one elastic member which is tightened, on the opposite ends, between the abutment means and a surface of said body, to determine, due to the pressure or counter-thrust to which the elastic member is subjected, a friction effect, which  
15 varies as a function of the rotation direction of said roller.

#### Brief Description of the Drawings

The characteristic features of the present invention will  
20 be pointed out in the following description of a preferred, but not sole embodiment, with reference to the enclosed drawings, in which:

- Figure 1 is a schematic view of a roll-up curtain in rolling up configuration;
- 25 - Figure 2 is a schematic view of the roll-up curtain in unrolling configuration;
- Figure 3 is a longitudinal section view of a head of the roller of the roll-up curtain, corresponding to the portion A of Figure 1;
- 30 - Figure 3A shows a variant of what is shown in Figure 3;

- 5 -

- Figure 4 is a cross-section view of the roller taken along the plane IV-IV of Figure 3;
- Figure 5 is a longitudinal section view of a head of the roller according to a different embodiment;
- 5 - Figure 6 is a cross-section view taken along the plane VI-VI of Figure 3;
- Figure 7 is a cross-section view taken along the plane VII-VII of Figure 5;
- Figures 8 and 9 are longitudinal section views of  
10 another embodiment of the head of the roller, in different operation steps;
- Figure 10 is the same longitudinal section view of a variant of the head of the roller.

#### 15 Best Modes of Carrying out the Invention

With reference to the above figures, the reference numeral 1 indicates the tubular roller, on which the curtain 2 rolls up.

20 The roller 1 is rotatably supported on a horizontal axis, by respective supports 3, which are integral with the stationary structure.

One end of the roller 1 abuts against a speed reducer connection group indicated as a whole with 4.

25 More in detail, the roller 1 couples in a prismatic way with a cup-like element 5, which consequently rotates together with the roller 1.

A head 6, introduced into the cavity formed by the cup-like element 5, is rigidly fastened to the support 3 of

- 6 -

the stationary structure by coupling with a prismatic appendix 7 of the element 5.

As described in detail in the European Patent EP 0900314, the head 6 features an axial toothed protrusion, which meshes with a plurality of planetary toothed wheels carried by a planetary wheel carrying member 8 and engages with a circumference tothing made on the inner surface of the cup-like element 5, so as to form a planetary gear.

10 The planetary wheel carrying member 8 is rigidly fastened to a threaded shaft 9, extending axially inside the roller 1.

The shaft 9 is a part of a friction device, indicated as a whole with 10, inserted into the roller 1.

15 The friction device 10 includes a cylindrical body 11, which features axially a threaded hole aimed at coupling with the shaft 9.

The cylindrical body 11 rotates together with the roller 1, but it can translate axially with respect thereto.

20 One end of an elastic member 12 acts on a surface of the cylindrical body 11, whereas the opposite end of the elastic member 12 abuts against a nut 13 screwed onto the shaft 9.

By acting on the nut 13 it is possible to adjust the pre-  
25 loading of the elastic member 12, consequently the elastic member 12 is subjected to pressure and counter-thrust.

According to the embodiment shown in Figures 3 and 4, the elastic member 12 preferably includes a helical leaf  
30 spring, obtained e.g. beginning from a cylindrical tubular element of e.g. steel or other material

- 7 -

fulfilling the same elastic function, in which a helical incision is made by mechanical cutting.

The spring obtained according to this embodiment compresses without deforming which assures a long  
5 duration. This type of helical leaf spring is particularly suitable for curtains which are heavy and/or of considerable dimensions.

As an alternative to the above described type of spring, it is possible to use a normal commercial spring, e.g. a  
10 helical spring (see Figure 3A), particularly indicated for currently used curtains: the material used is, e.g. steel kind or other material fulfilling the same elastic function.

The working of the device will be described in the  
15 following.

When the curtain 2 is pulled, by acting directly thereon by e.g. a lower ring 20, the roller 1 is made to rotate on the supports 3.

The roller 1 drives the shaft 9, inserted axially  
20 therein, into rotation with an angular travels suitably reduced by the reducer group 4 which acts as an intermediary.

In other words, the shaft 9 rotates with a relatively lower extension with respect to the roller 1.

25 The relative rotation of the shaft 9 with respect to the roller 1 determines an axial translation of the cylinder 11 of the friction group 10, whose rotation with respect to the same roller 1 is prevented by suitable prismatic coupling means, e.g. a pair of opposite teeth 14, guided  
30 in corresponding inner grooves of the roller 1, as seen in Figure 6.

- 8 -

The axial translation of the cylinder 11 causes a progressive change of the length K of the spring 12, which is stationary at the abutment on the nut 13, and consequently, a progressive change of the compression of  
5 the spring 12.

Accordingly, the initial compression of the spring can be suitably adjusted, by registering the position of the nut 13.

Obviously, the bigger or smaller compression of the  
10 spring 12 changes the elastic thrust action exerted on the cylinder 11 and consequently, avoids the fall of the curtain during the unrolling step.

Practically, during the curtain 2 unrolling, the compression of the spring 12 is progressively increased  
15 and consequently, also the friction effect is increased.

On the contrary, during the curtain 2 rolling up, the spring 12 is progressively released and consequently, the friction effect is reduced.

This allows especially to contrast in a suitable way the  
20 curtain 2 unrolling, with an increasing braking effect due to the friction, so as to prevent the curtain 2 fall during the unrolling step.

On the contrary, the braking effect is reduced progressively during the curtain 2 rolling up.

25 As a consequence, the rapid fall of the curtain is advantageously prevented, even if the curtain is relatively heavy.

Figure 5 shows a different embodiment of the friction device, used in particular with roll-up curtains operated  
30 by a chain or other similar means.

- 9 -

The chain engages with a shaped groove of a pulley 15 made on the outer edge of the cup-like element 5 of the reducer group 4.

According to this solution, the cylinder 11 is acted upon  
5 by an elastic member 12 formed in the shown example by a pair of helical springs 12a and 12b which push on an intermediate disc 16.

The elastic member 12 abuts against the adjustment nut 13 screwed on the shaft 9, against which an additional  
10 cylindrical body 17 goes in abutment, stressed by a relative elastic member 18, which on its turn goes in abutment against a further adjustment nut 19.

The additional cylinder 17 is not screwed on the threaded shaft 9, but the latter passes freely through an axial  
15 hole of suitable diameter made in the cylinder 17 (see also Figure 7).

Therefore, the rotation of the shaft 9 due to the rotation of the roller 1 during the curtain 2 rolling up and unrolling, determines only the translation of the  
20 cylinder 11, as described previously.

The additional cylinder 17, on which the spring 18 acts, determines a friction effect of constant value, adjustable in pre-loading step by the nut 19.

Figures 8 and 9 show another embodiment of the friction  
25 device 10, in which the elastic member 12 is advantageously formed by a plurality of balls 21, made of elastic material, e.g. neoprene rubber or another elastic material.

The balls 21, suitably bored along a diametric axis, are  
30 put on the shaft 9 of the friction device, close to each other.

- 10 -

The balls 21 of elastic material are clamped between a pair of abutment disks 22, 13, which are supported respectively by the cylinder 11 and by the planetary wheel carrying member 8 connected to the reducer connection group 4: also in this case the elastic means, i.e. the balls 21, are subjected to pressure or counter-thrust.

In rest position, i.e. when the curtain 2 is rolled up, the balls 21 are not compressed and consequently do not perform braking action (Figure 8).

On the contrary, during the unrolling of the curtain 2, the balls 21 are progressively compressed due to the axial translation of the cylinder 11, as seen in Figure 9.

Obviously, the compression of the balls 21 increases progressively the elastic thrust performed on the cylinder 11 and consequently also the friction effect performed between the contacting surfaces.

Obviously, the number of the balls 21 can suitably vary in relation to the dimensions of the roll-up curtain.

The balls 21 can also have different elastic reaction characteristics, due to e.g. different hardness of the elastic material of which they are made. Also, balls with different diameters can be used. Balls 21 with different elastic reaction characteristics can be also included in a definite series of balls 21.

For instance, the braking effect of the friction device can be correspondingly changed by substituting one or more balls 21 of the series with others of different characteristics and/or different diameters.

- 11 -

In practical terms, it allows to meet a wide range of needs.

The balls 21 of elastic material can have a flattened outline 24, which avoids any interference with the inner  
5 surface of the roller 1 while being compressed (see Figure 10).

The proposed device which uses the balls 21 is particularly designed for economic curtains.

Consequently, the proposed friction device fulfills the  
10 object to avoid the fall of the roll-up curtain during the unrolling step, even if the curtain is relatively heavy.

A prerogative of the proposed friction device derives from the fact that it performs an increasing braking  
15 action during the curtain unrolling, so as to contrast efficiently the corresponding increase of the curtain descent speed and, consequently creates substantially uniform operation conditions.

It is also to be pointed out that the friction device can  
20 be advantageously used with roll-up curtains equipped with return elastic means, as well as with roll-up curtains operated manually, so that its use is universal.

In case of curtains operated by chain, the proposed device is not damaged if the operator acts manually on  
25 the curtains.

The particular conformation of the proposed solution makes the corresponding device universal, i.e. valid for curtains with operating chain situated on the left as well as on the right.

30

- 12 -

The embodiments of the invention in which an exclusive property or privilege is claimed are defined as follows:

1. A friction device for roll-up curtains comprising:
  - a tubular roller on which a curtain rolls up, a threaded shaft located along a horizontal axis of the tubular roller which is rotatably carried on the horizontal axis, the threaded shaft situated axially inside said roller and connected to the roller by interposition of an angular speed reducer group;
  - a body mounted sliding and axially inside said roller and screw-coupled with said threaded shaft, so as to translate axially due to the rotation of said threaded shaft during unrolling or rolling up of said curtain on said roller; and
  - at least one elastic member which is tightened on opposite ends thereof, between abutment means and a surface disposed on said threaded shaft, to determine, due to the pressure or counter-thrust to which the elastic member is subjected, a friction effect, which varies as a function of the rotation direction of said roller, said elastic member including a plurality of balls of elastic material, bored along a diametric axis, and set on said threaded shaft close to each other.
2. The friction device according to claim 1, wherein said elastic material is neoprene type rubber, synthetic elastic material or natural elastic material.
3. The friction device according to claim 1 or 2, wherein said balls have different diameters.
4. The friction device according to claim 1, 2 or 3, wherein said balls have different elastic reaction

- 13 -

characteristics, being produced with elastic materials having different hardness.

5. The friction device according to claim 1, 2 or 3, wherein said balls have differentiated compression characteristics, being produced with elastic material having different hardness.

6. The friction device according to any one of claims 1 to 5, wherein said balls have different diameters.

7. The friction device according to any one of claims 1 to 6, wherein said balls have a flattened peripheral outline to avoid interference with an inner surface of said tubular roller.

8. The friction device according to any one of claims 1 to 7, wherein said angular speed reducer group drives said threaded shaft into rotation with angular displacements reduced with respect to said roller, during curtain unrolling.

9. The friction device according to any one of claims 1 to 8, wherein said body includes a cylinder equipped with means for prismatic coupling with said roller.

10. The friction device according to claim 9, wherein said means for prismatic coupling includes a pair of teeth made in diametrically opposite positions on said cylinder and guided in corresponding inner grooves of said roller.

- 14 -

11. The friction device according to any one of claims 1 to 10, wherein said abutment means includes a nut adjustably positioned on said threaded shaft.

12. The friction device according to any one of claims 1 to 11, further comprising an additional body which goes in abutment against said abutment means, stressed by a second elastic member, which in turn goes in abutment against further abutment means.

13. The friction device according to claim 12, wherein said threaded shaft passes freely through said additional body.

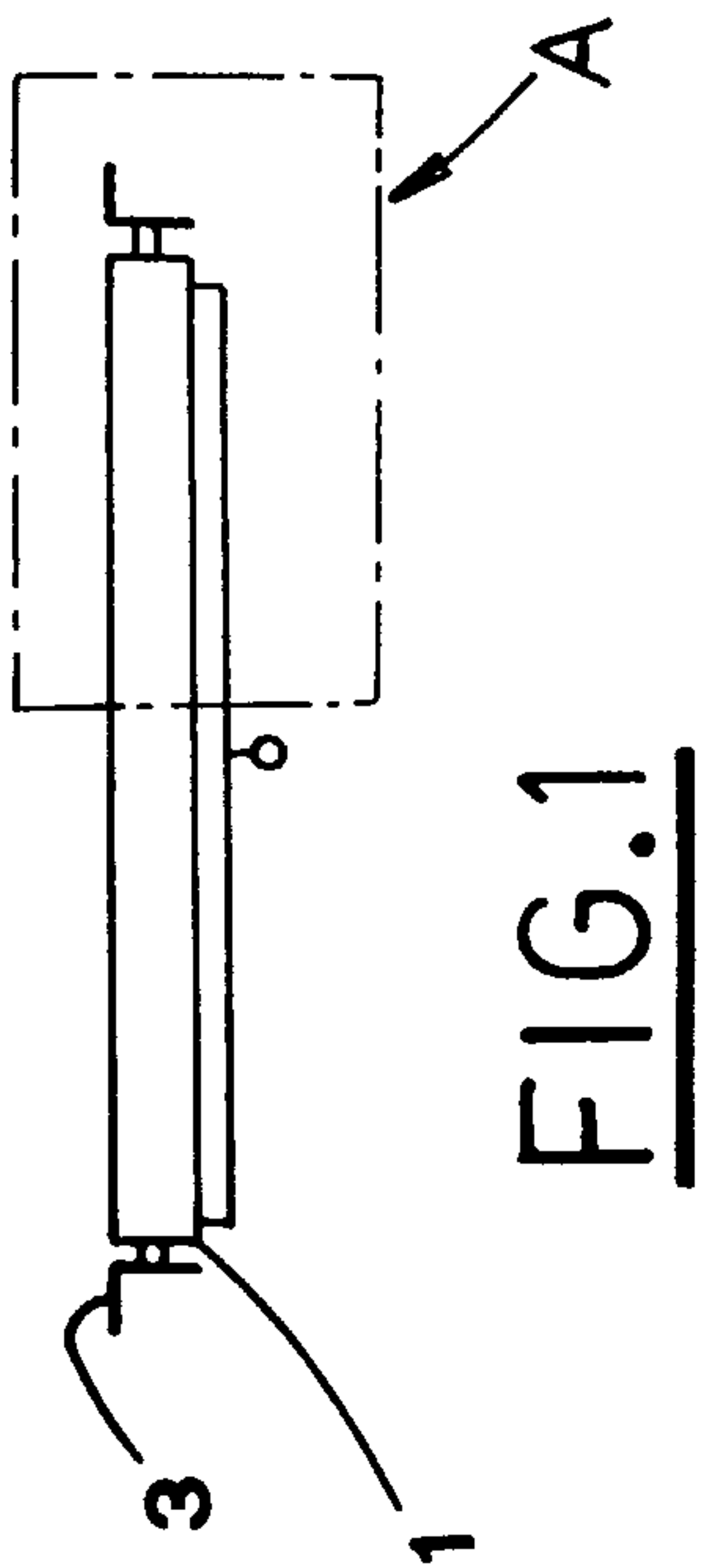

FIG. 1

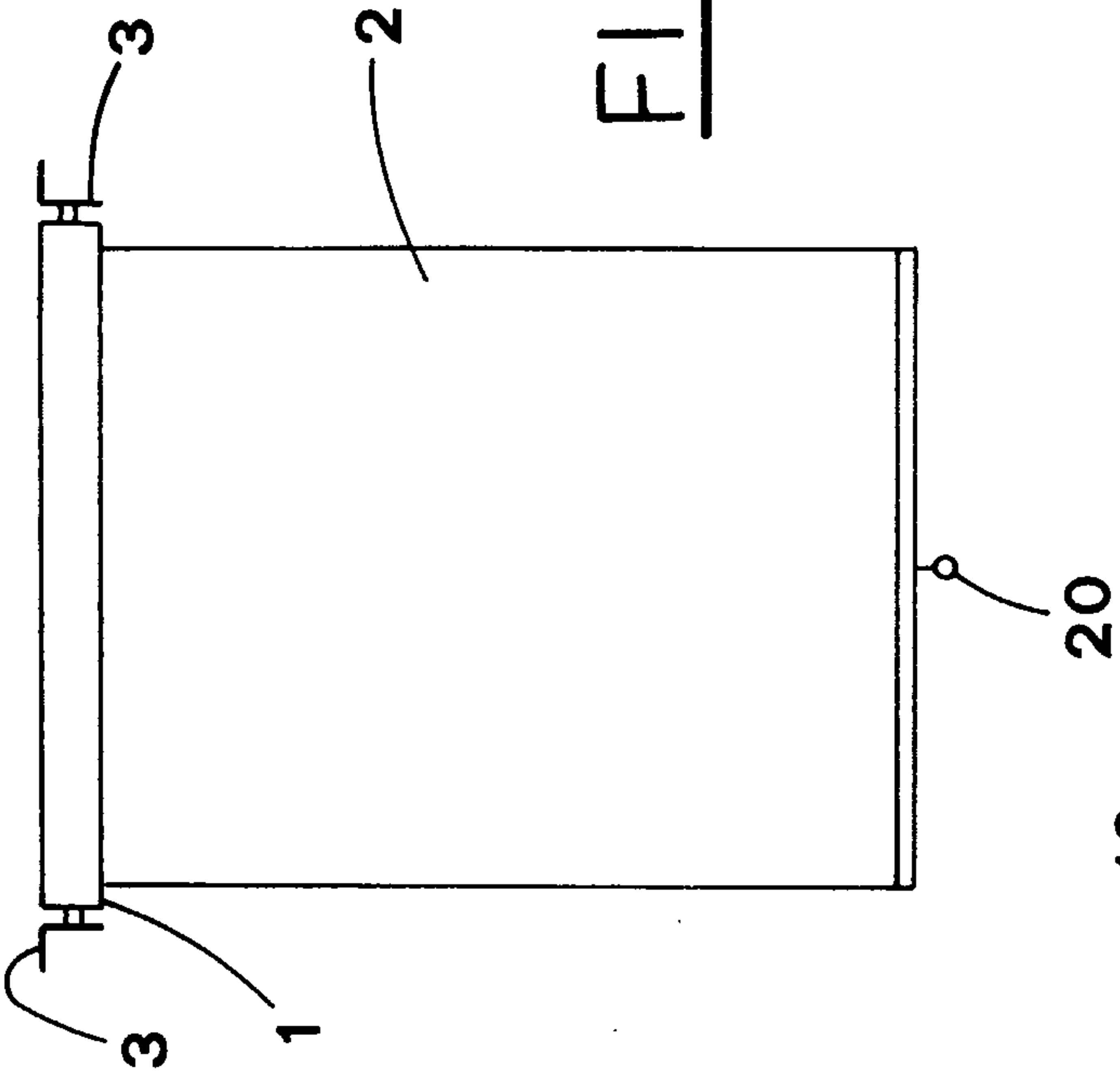

FIG. 2

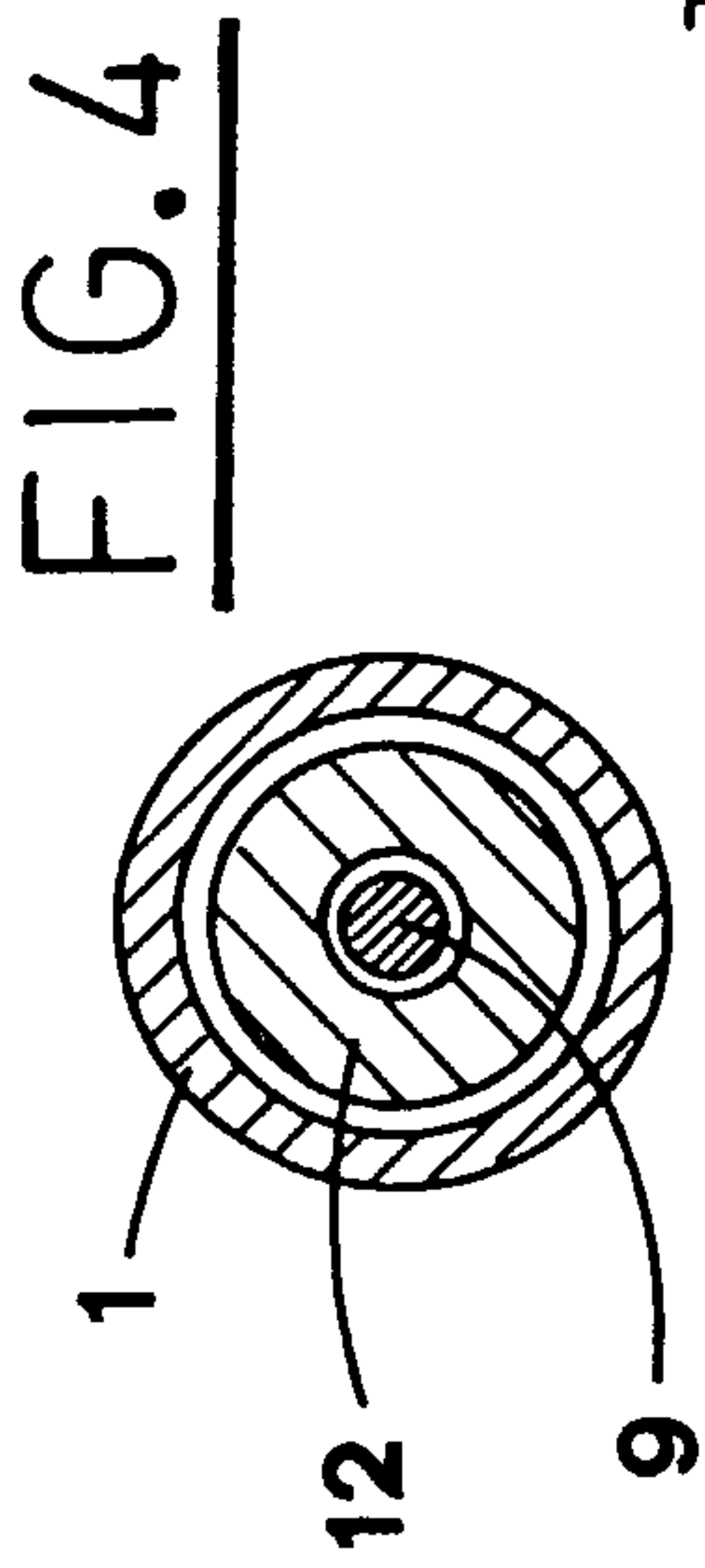

FIG. 4

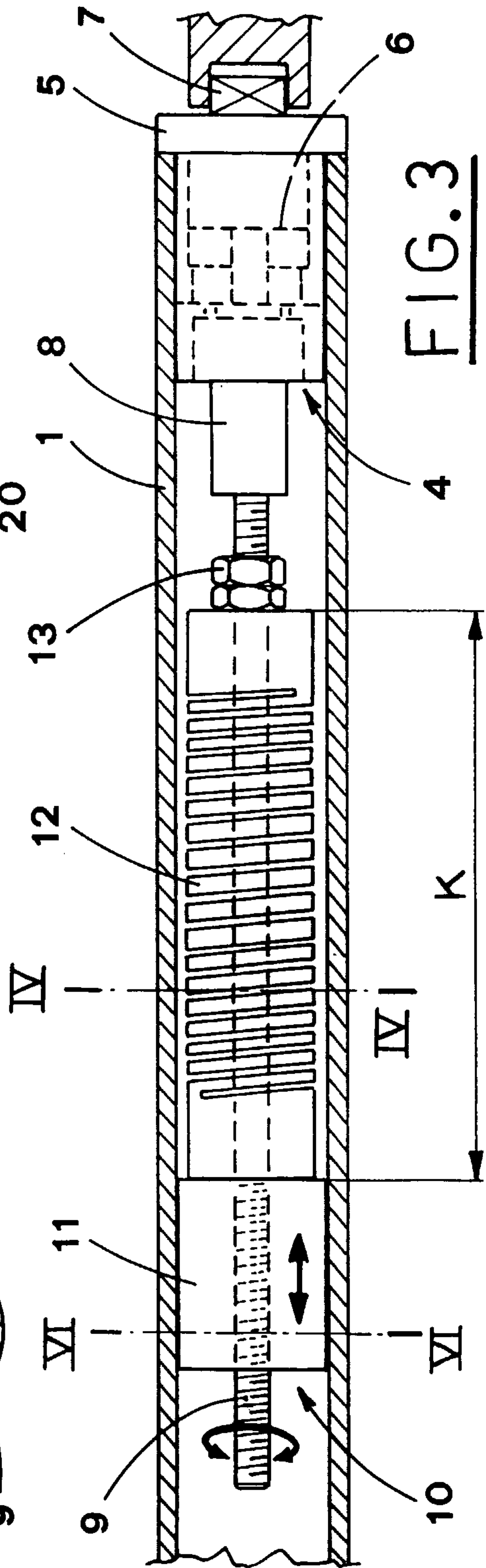

FIG. 3

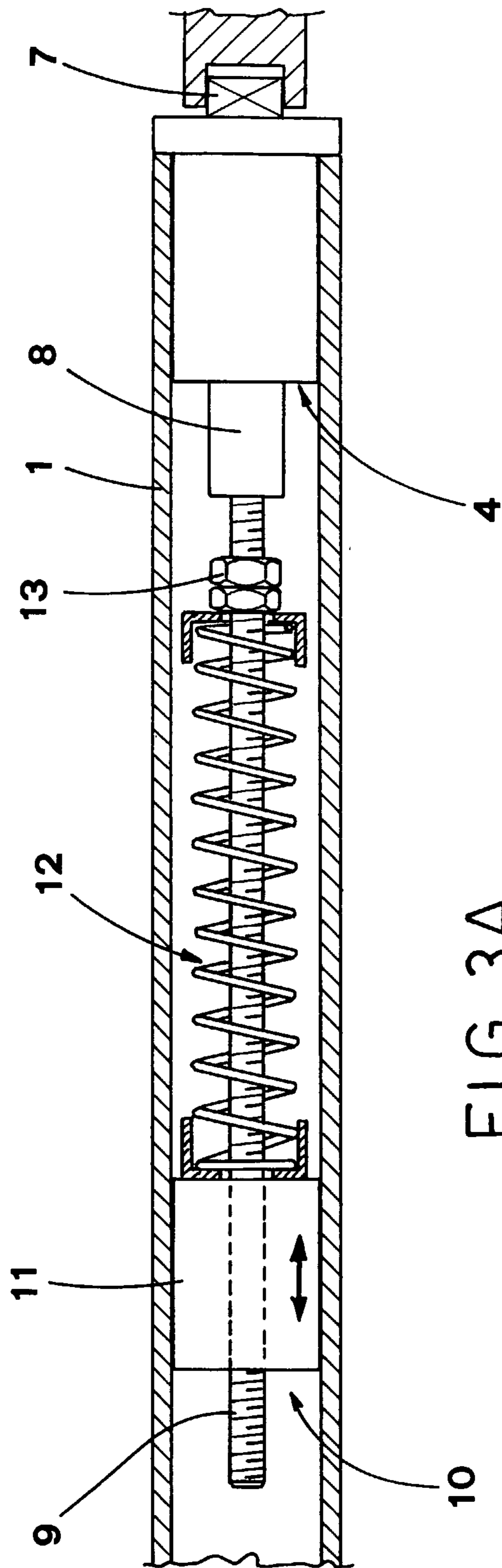

FIG. 3A

FIG. 5

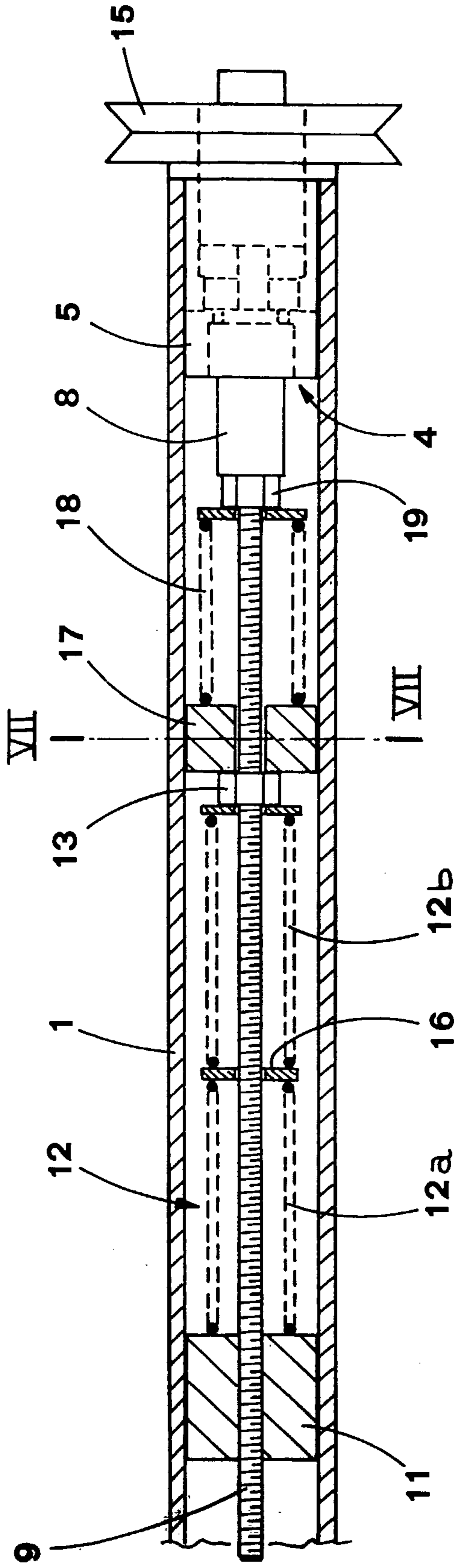

FIG. 6

FIG. 7

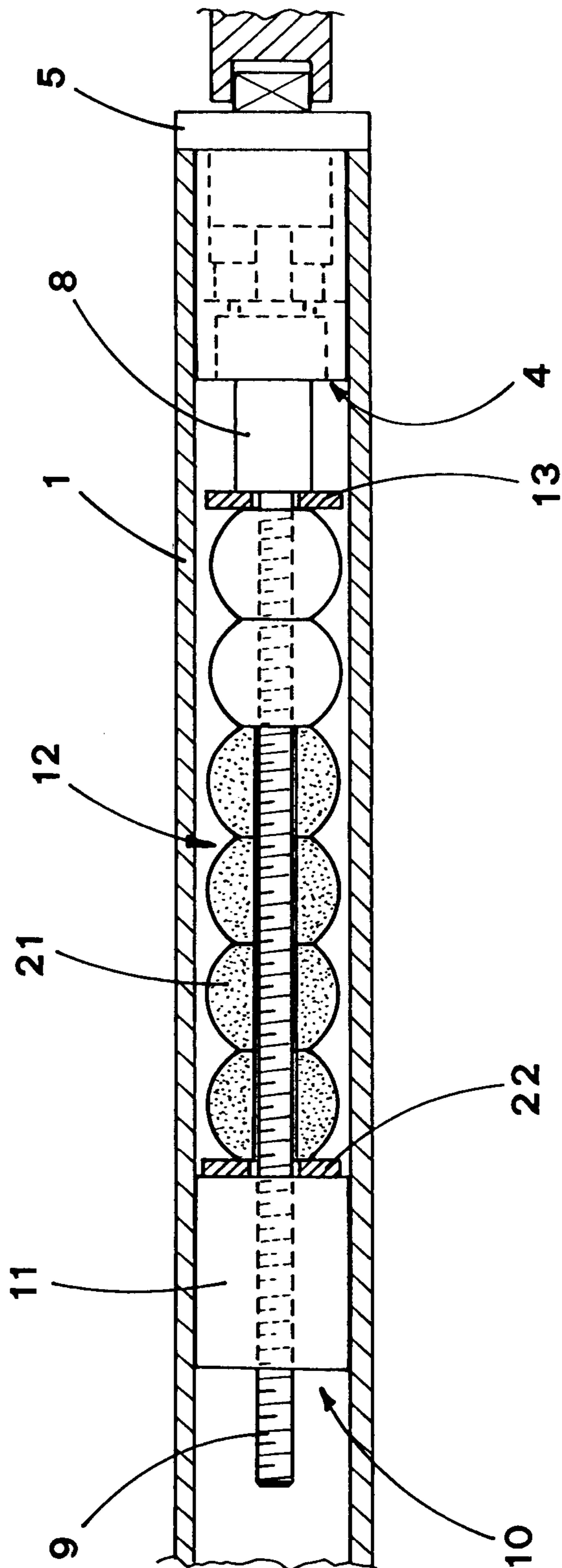

FIG. 8

