

[54] CHAIN LOCK

[72] Inventor: Horst Elsässer, Hauffstrasse 15, 7084 Unterkochen/Wurttemberg, Germany

[22] Filed: April 27, 1970

[21] Appl. No.: 32,196

[30] Foreign Application Priority Data

April 25, 1969 Germany.....P 19 22 149.9

[52] U.S. Cl.....59/35, 59/85

[51] Int. Cl.....F16g 15/04

[58] Field of Search.....59/35, 84, 85, 86, 90, 92, 59/93, 12

[56] References Cited

UNITED STATES PATENTS

1,517,346 12/1924 Crandall.....59/86

2,010,853	8/1935	Dyer.....	59/86
2,001,606	5/1935	Gerstein.....	59/85
R5,740	1/1874	Lamb.....	59/85
2,869,255	1/1959	Page.....	59/86
1,044,792	11/1912	Levy.....	59/85
891,153	6/1908	Dowse.....	59/85

Primary Examiner—Charles W. Lanham

Assistant Examiner—Gene P. Crosby

Attorney—Smythe & Moore

[57] ABSTRACT

A chain lock including a lock element consisting of an open chain link, wherein the opening thereof defines an entry slot whereby adjacent lengths of chain may be joined together. The portions adjacent the entry slot are provided with two axially aligned bores for receiving a rod-like connecting element which closes the entry slot.

8 Claims, 15 Drawing Figures

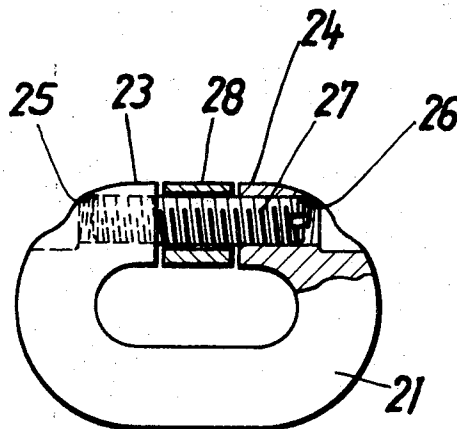

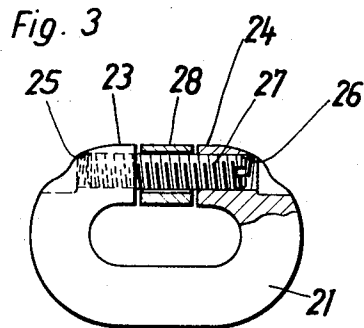
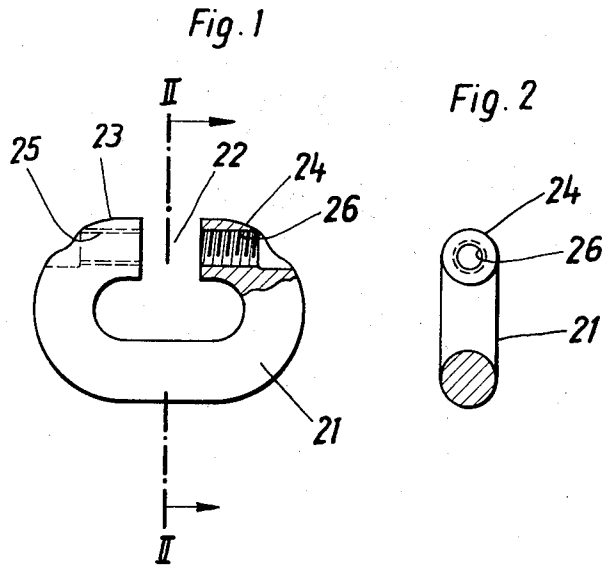

Inventor:
HORST ELSÄSSER
BY *Smythe & Moore*
ATTORNEYS

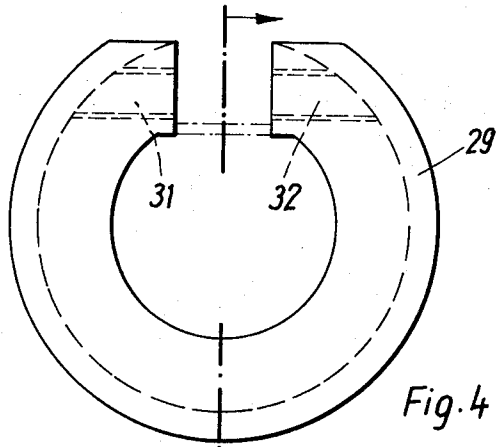

Fig. 4

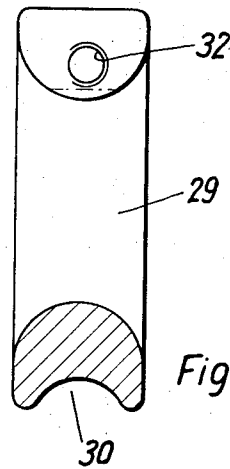

Fig. 5

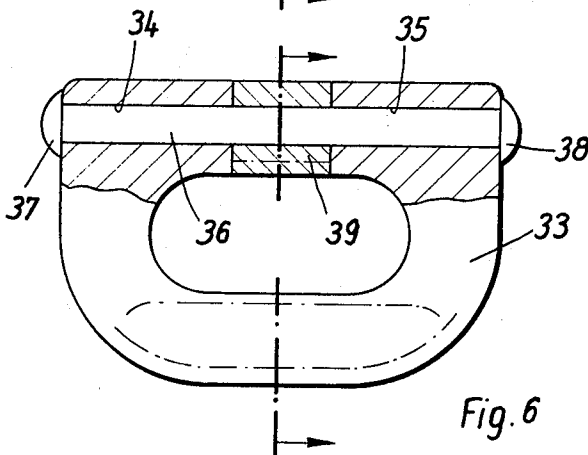

Fig. 6

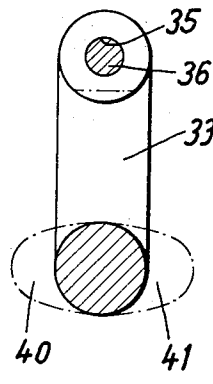

Fig. 7

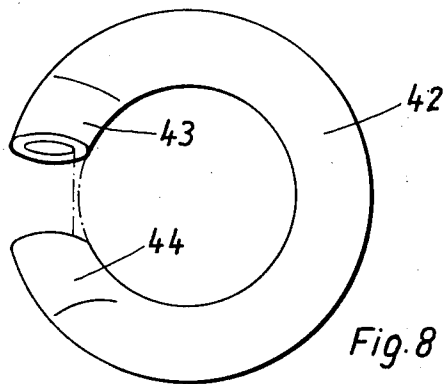

Fig. 8

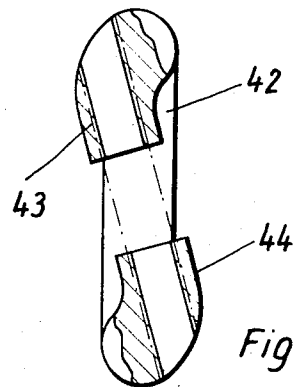
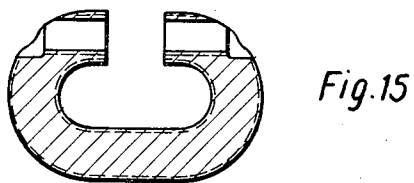
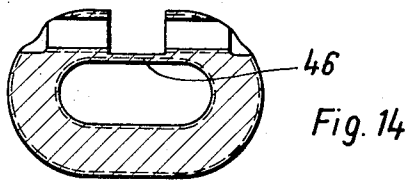
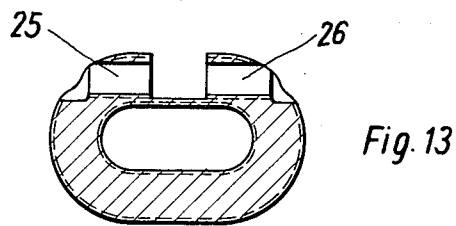
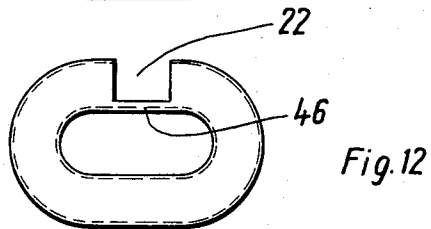
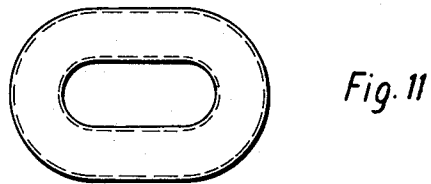
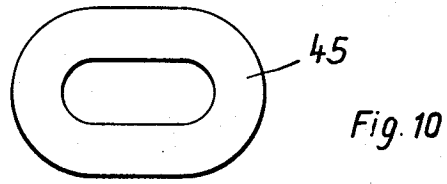

Fig. 9

Inventor:
HORST ELSÄSSER

BY *Smay the & Moore*
ATTORNEYS,



Inventor:
HORST ELSÄSSER
BY *Smythe & Moore*
ATTORNEYS

CHAIN LOCK

This invention relates to a chain lock consisting of a basic element made out of an open chain link, the sections thereof defining an entry slot for the connecting members of lengths of chain to be joined together being adapted to be connected together for the purpose of closing the lock.

Already known is a chain lock of the kind mentioned above having a C-shaped basic element, in which the ends defining the entry slot each have a projection over which a clip may be placed which serves to join the said ends, it being possible to lock the said clip in its locking position by means of a web-like insert and a pin (U.S. Pat. No. 2,175,504). The known chain lock is unsatisfactory because its design is relatively complicated and it is difficult to produce all of the parts thereof economically with such accuracy that they can be joined together without any finishing operations and also substantially without play. Another disadvantage is that the lock consists of four parts which must be completely separated from each other when the lock is assembled or dismantled.

Another known chain lock of the type in question also has a C-shaped basic element with a closing member adapted to be locked in its closed position by means of a pin (German Utility Model 1.802.938). In this second chain lock, the ends of the basic element are provided with dove-tail projections over which dove-tail recesses in the closing member may be pushed. Here again, this lock is costly to produce and it is impossible to avoid play between the individual parts thereof.

Still another known chain lock having a C-shaped basic element also consists of four parts, the ends of the basic element defining the entry slot exhibiting annular flanges capable of being bridged by means of two shells connected together by a rivet. (German Patent 155.954). Again this chain lock is complex and, like all of the foregoing chain locks, it has a web which makes it impossible to use a chain fitted with such a lock in conjunction with chain sprockets.

Finally, chain locks having no internal webs are known, the opposing ends of which are adapted to be joined together with the aid of a screw arranged therebetween, and through annular discs moving perpendicularly to the plane of the chain link(s), and capable of being pressed against bearing surfaces on the ends of the chain link(s) (German Utility Model 1.971.292). Again these known chain locks are not fully satisfactory, since the considerable amount of space taken up by the connecting elements makes them unsuitable for use in conjunction with chain sprockets, and they also have five parts.

It is the aim of the invention to develop a chain lock of the type described at the beginning hereof, the said lock having few parts and as far as possible only one connecting element, the said connecting element being of such a configuration and being arranged in such a manner that it does not project beyond the basic element near the entry slot when the lock is closed. In spite of its asymmetrical design, the new chain lock is to be equally resistant to alternating loads as known symmetrical chain locks made in two halves with half links. According to the invention, this aim is accomplished in that the ends of the basic element exhibit two bores in alignment with each other which serve to accommodate a substantially cylindrical connecting element which, in its closed position, bridges over the entry slot.

comodate a substantially cylindrical connecting element which, in its closed position, bridges over the entry slot.

The chain lock according to the invention offers a series of advantages. For instance, in the vicinity of the entry slot, the connecting element has no projections and therefore does not project into the free inner space of the basic element which may therefore be utilized to the full. It is impossible for the lock to become jammed as a result of projecting parts. The chain lock may have the dimensions and the profile of a normal chain link and may be used in conjunction with gearwheels and pocketed sprocket wheels. The lock is easy to manufacture, as explained hereinafter; it is also easy to manipulate.

It has been found of particular advantage to make the connecting element in the form of a threaded pin adapted to be screwed into internally threaded bores. This design provides extremely simple assembly. The manufacturer may screw the threaded pin into one bore in the longitudinal leg, so that when the lock is used the pin need only be screwed in until it enters the other bore.

For reasons of strength, and in view of the stress distribution in the loaded basic element, it has been found advisable to arrange the bores so that they are slightly offset towards the outside of the lock.

The "waist" occurring in two-piece chain locks in the vicinity of the entry slot may be avoided if the connecting element is surrounded in the vicinity of the entry slot, with a bush, the outer surface of which is flush with the adjacent outer surfaces of the ends of the basic element. This not only increases the similarity between the chain lock and a normal chain link, but also protects the thread on the pin in the vicinity of the entry slot.

The basic element may be oval or round, i.e., it may be made out of a normal oval or round link. On the other hand, it may also be shaped differently, for instance substantially triangular or D-shaped. If the lock is to be used for anti-skid or tire-protecting chains, it is of advantage with certain chain designs to turn the ends of the basic element slightly out of the plane thereof, in order to make the bores more accessible.

The manufacture of chain locks having a basic element made out of an open chain link, the shape of which must match the shape of the connecting element, is fraught with extraordinary difficulties if hardening is necessary in order to increase wear-resistance. Means have hitherto been lacking of overcoming distortion of the basic element due to hardening, and allowance has usually had to be made for unwanted play, finishing operations, or stressing of the basic element when the lock is closed. According to another proposal of the invention, it is possible to eliminate these disadvantages by closing the basic element, in the vicinity of the entry slot, during the heat-treatment, with a narrow bridge of residual material. If this teaching according to the invention is followed, a basic element free of distortion is obtained which is not under internal stress when the connecting element is fitted. Such internal stresses tend to impair the fatigue strength of a lock.

In manufacturing a chain lock having a connecting member consisting of a screw, it has been found of particular advantage first of all to carburize the basic ele-

ment and to chill it slightly, then to produce the bores and to thread them in the non-carburized area, after which the carburized edges are hardened, and finally the bridge of material is removed. This not only prevents distortion of the basic element, but also ensures that the threads in the bores are in the tough core.

The invention is explained in greater detail hereinafter with the aid of a plurality of examples of execution illustrated in the drawing attached hereto, wherein:

FIG. 1 shows a side elevation in part section of the basic element of a chain lock according to the invention;

FIG. 2 is a section along the line II—II in FIG. 1;

FIG. 3 shown in part section an assembled chain lock having the basic element of FIGS. 1 and 2;

FIG. 4 shows the shape of a second basic element;

FIG. 5 is a section along the line V—V in FIG. 4;

FIG. 6 shows another chain lock according to the invention, in part section;

FIG. 7 is a section along the line VII—VII in FIG. 6;

FIG. 8 is a circular basic element with the ends arranged at an angle to the plane of the basic element;

FIG. 9 is a plan view in part section of the entry slot in the basic element in FIG. 8, and

FIGS. 10–15 show the basic element of the chain lock in FIGS. 1 to 3 in various production stages.

In FIGS. 1 to 3, 21 indicates the basic element of a chain lock produced by making a slot 22 in a chain link. The width of slot 22 is 1.1 times the diameter of the material of the connecting links of the lengths of chain to be joined together.

Sections 23,24 of the one leg of the basic element, adjacent slot 22, are provided with aligned bores 25,26 which are internally threaded. The said bores accommodate a connecting element 27 made of a threaded pin, covered in the region of the slot by a bush 28.

The threaded pin is slightly offset towards the outside, but its position is such that the notch-sensitive threads in bores 25,26 are not in the hardened part of basic element 21, but in the tough core thereof.

FIGS. 4 and 5 show a basic element 29 made out of a circular ring provided with a groove 30. This basic element also has aligned bores 31,32, into which a screw is inserted from one end.

FIGS. 6 and 7 show a riveted design of chain lock. D-shaped basic element 33 has two bores 34,35 into which a rivet 36 is introduced and secured in the position shown by means of heads 37,38. Bush 39 surrounds the rivet in the vicinity of the entry slot for the connecting chain links. As indicated by the dotted lines, the closed leg of the basic element may be provided with laterally projecting beads 40,41.

In basic element 42 in FIGS. 8 and 9, ends 43,44 are made slightly oblique in order to facilitate the fitting of the screw.

For the purpose of ensuring that the basic element does not distort during hardening, it is produced in a specific manner discussed below in conjunction with FIGS. 10 to 15. In the example illustrated, manufacture begins with an oval chain link 45 of high strength (FIG. 10). The first operation consists in carburizing and slightly chilling this link (FIG. 11). Gap 22 is then milled into one leg of the link, leaving a narrow bridge 46 to prevent the basic element from becoming

distorted during the heat-treatment process. After this milling operation, aligned bores 25,26 are produced and are internally threaded (FIG. 13). Thereafter the basic element is hardened, acquiring a highly wear-resistant hard layer in the vicinity of its carburized edge (FIG. 14). Fully hardened bridge 46, the thickness of which is equal to 0.1 times the diameter of the chain link, is finally broken off with a slight blow with a hammer, and basic element 21 of the chain lock in FIGS. 1 to 3 is finished. The basic elements of the other types of lock are, of course, produced in a similar manner. The initial link may also be a drop-forging of the shape shown in FIG. 12.

I claim:

1. A chain lock consisting of a generally oblong chain link body member, said member having two relatively short end sections and two longer side sections, an opening in one of said side sections providing an entry slot to permit the entry of adjacent chain links therethrough for chain connection, said open side section having two horizontal bores arranged slightly offset toward the outer edge of said body member, said bores being axially aligned with each other on either side of said entry slot, a substantially cylindrical rod-like connecting element passing through said bores and closing said entry slot, said connecting element being surrounded by a bushing, the external surface of which lies flush with the external surfaces of said body member, whereby when assembled in a chain said adjacent links engage with and bear against the inner faces of said end sections.

2. A chain lock according to claim 1, wherein said horizontal bores and said connecting element are threaded.

3. A chain lock according to claim 1, wherein said chain link body member is D-shaped.

4. A chain lock according to claim 1, wherein the side section having the bores therein is generally oblique relative to the plane of said lock to facilitate the assembly of the connecting member thereinto.

5. A method for producing a generally oblong chain lock comprising the steps of carburizing and chilling a continuous chain link, milling a gap in one leg of said link to leave a narrow bridge connecting the opposing portions of said one leg, drilling aligned horizontal bores through said opposing portions, hardening said link, and finally removing said narrow bridge.

6. A method including the steps of claim 5 wherein the horizontal bores are threaded before said link member is hardened.

7. A chain lock consisting of a generally oblong chain link body member, said member having two relatively short end sections and two longer side sections, an opening in one of said side sections providing an entry slot to permit the entry of adjacent chain links therethrough for chain connection, said open side section having two horizontal bores axially aligned with each other on either side of said entry slot, a substantially cylindrical rod-like connecting element passing through said bores and closing said entry slot, whereby when assembled in a chain said adjacent links engage with and bear against the inner faces of said end sections.

8. A chain lock consisting of a generally circular body member, said member having an opening forming

5

an entry slot to permit the entry of adjacent chain links therethrough for chain connection, the end portions adjacent the entry slot having two horizontal bores axially aligned with each other on either side of said entry slot, and a substantially cylindrical rod-like connecting

6

element passing through said bores and closing said entry slot, said connecting element being surrounded by a bushing, the external surface of which lies flush with the external surface of said body member.

* * * * *

10

15

20

25

30

35

40

45

50

55

60

65