

(19) World Intellectual Property Organization
International Bureau



(43) International Publication Date
22 January 2009 (22.01.2009)

PCT

(10) International Publication Number
WO 2009/010366 A1

- (51) **International Patent Classification:**
E04B 1/21 (2006.01) E04C 3/294 (2006.01)
E04B 5/38 (2006.01) E04C 5/065 (2006.01)
- (21) **International Application Number:**
PCT/EP2008/057760
- (22) **International Filing Date:** 19 June 2008 (19.06.2008)
- (25) **Filing Language:** English
- (26) **Publication Language:** English
- (30) **Priority Data:**
MI2007A001455 19 July 2007 (19.07.2007) IT
- (71) **Applicant (for all designated States except US):** LEONE, Lucio [IT/IT]; F.lli Cervi Res. Parco, I-20090 Segrate (IT).
- (71) **Applicant and**
(72) **Inventor:** LEONE, Ubaldo [IT/IT]; Strada dei Lecci 13/2, I-33030 Campofornido (IT).
- (74) **Agents:** PIZZOLI, Antonio et al.; Società Italiana Brevetti S.p.A., Via Carducci 8, I-20123 Milano (IT).
- (81) **Designated States (unless otherwise indicated, for every kind of national protection available):** AE, AG, AL, AM, AO, AT, AU, AZ, BA, BB, BG, BH, BR, BW, BY, BZ, CA, CH, CN, CO, CR, CU, CZ, DE, DK, DM, DO, DZ, EC, EE, EG, ES, FI, GB, GD, GE, GH, GM, GT, HN, HR, HU, ID, IL, IN, IS, JP, KE, KG, KM, KN, KP, KR, KZ, LA, LC, LK, LR, LS, LT, LU, LY, MA, MD, ME, MG, MK, MN, MW, MX, MY, MZ, NA, NG, NI, NO, NZ, OM, PG, PH, PL, PT, RO, RS, RU, SC, SD, SE, SG, SK, SL, SM, SV, SY, TJ, TM, TN, TR, TT, TZ, UA, UG, US, UZ, VC, VN, ZA, ZM, ZW.
- (84) **Designated States (unless otherwise indicated, for every kind of regional protection available):** ARIPO (BW, GH, GM, KE, LS, MW, MZ, NA, SD, SL, SZ, TZ, UG, ZM, ZW), Eurasian (AM, AZ, BY, KG, KZ, MD, RU, TJ, TM), European (AT, BE, BG, CH, CY, CZ, DE, DK, EE, ES, FI, FR, GB, GR, HR, HU, IE, IS, IT, LT, LU, LV, MC, MT, NL, NO, PL, PT, RO, SE, SI, SK, TR), OAPI (BF, BJ, CF, CG, CI, CM, GA, GN, GQ, GW, ML, MR, NE, SN, TD, TG).
- Published:**
— with international search report

(54) **Title:** IMPROVED GIRDERS FOR REINFORCING CONCRETE AND METHOD FOR CONNECTING THEM TO PILLARS IN ORDER TO PROVIDE CONTINUITY FROM BAY TO BAY

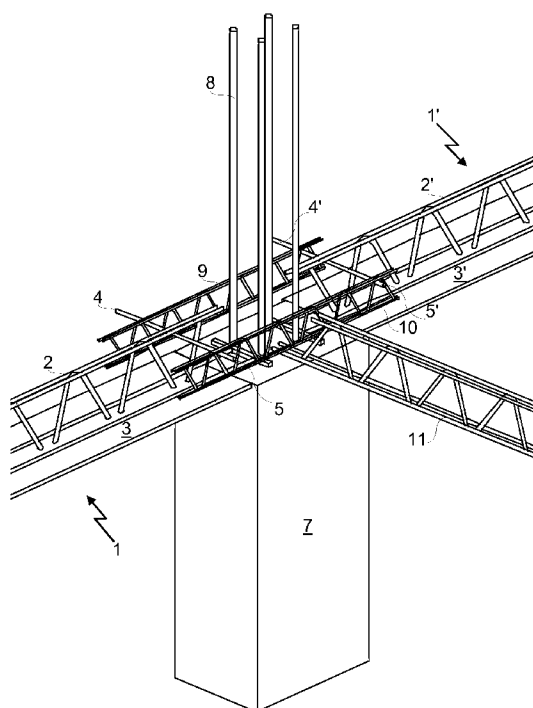

Fig. 5

(57) **Abstract:** A girder (1) for reinforcing structural members made of reinforced concrete is described, the girder comprising at least one truss (2) and being provided with at least one lateral protrusion (4, 5) in correspondence to its ends. A method for connecting two girders (1, 1'), being substantially arranged along the same direction, to a reinforced concrete pillar (7) is also described, wherein at least one short reinforcing member (9, 10) is arranged aside the girders (1, 1') in correspondence to the pillar (7).

WO 2009/010366 A1

IMPROVED GIRDERS FOR REINFORCING CONCRETE AND METHOD FOR CONNECTING THEM TO PILLARS IN ORDER TO PROVIDE CONTINUITY FROM BAY TO BAY

5 The present invention relates to girders for the manufacturing of structures for constructions and for reinforcing substantially horizontal structural members made of reinforced concrete and to a method for connecting these structural members to pillars. In particular the invention relates to a girder comprising prefabricated trusses and provided with lateral protrusions suitable for supporting short members for reinforcing
10 the connecting knot between girders and pillar as well as for connecting the girders of adjacent bays in a continuous way.

 Metal girders made up of prefabricated trusses welded on a metal plate for the manufacturing of reinforced concrete constructions are already known. These girders are identified by the REP[®] mark, which has been registered in the applicant's name.
15 These girders allow to reinforce substantially horizontal structural members made of reinforced concrete, thus reducing the cost resulting from provisional reinforcing operations, as well as the amount of iron and concrete needed for manufacturing these structural members. Moreover, the placement of the above-mentioned girders does not require skilled labour for manually manufacturing the reinforcing structure on the
20 building site.

 The girders are usually supported by reinforced concrete pillars in order to manufacture the supporting structure of a construction. The connecting knot between girders and pillars must be strong and in particular the structural continuity between the girders of adjacent bays supported by these pillars must be ensured.

25 Italian patent 1248021 in the applicant's name describes girders whose truss is remarkably longer than the plate longitudinally fixed underneath it, which plate has a length equal to the clear span between the two pillars connected by the girder. In this way the truss may be inserted in the space between the substantially vertical members reinforcing the pillar, thus protruding beyond the pillar in order to go aside the truss of a
30 subsequent girder. Similarly, the truss of the subsequent girder is longer than the plate underlying it so as to cross the substantially vertical members reinforcing the pillar in

order to go over the plate of the first girder. In this way, once cast concrete the knot between the girders and the pillar is very strong from the static point of view. However, this solution has a drawback that it is difficult to insert the trusses of the girders between the reinforcing members of the pillars. Due to this problem in fact it happens that some
5 workers in the building site must even cut some of the reinforcing members of the pillars in order to form a space in which the trusses of the girders are rested. It is obvious that in this way the structural continuity of the pillar is interrupted, although only partially, thus jeopardizing its static strength characteristics.

Short reinforcing members used for reinforcing the knots between girders and
10 pillars are also known, such as for example the short reinforcing members described in Italian patent 1037265. Usually, known short reinforcing members have a specifically shaped geometry, are inserted between the members reinforcing the pillars and protrude beyond the pillars extending towards the inside of the girders to be connected. However, both placing and fixing of these short reinforcing members are laboring operations that
15 require additional time. This results in further manufacturing costs, as well as in a remarkable extension of the manufacturing time. It should be noted that the knot is not provided with a mixed structure comprising prefabricated steel members and concrete, as these short reinforcing members are substantially non-prefabricated reinforcing members that must be subsequently connected to the reinforcing members of the pillar
20 and/or reinforced with cages in a typical way in reinforced concrete constructions. At present the Italian standards tend to discourage the combined use of mixed structures and reinforced concrete structures in order to obtain better structural performances.

The above-mentioned known girders are generally comprised of trusses formed of bars having a constant cross-section. The cross-section of the bars is so sized that the
25 girder can withstand the shearing forces proximate to its ends, i.e. proximate to the pillar on which the girder sits. Therefore, the cross-section of said bars is oversized in the centre portion of the girders, where smaller cross-sections would be enough to withstand the bending moment. Known girders thus have the disadvantage of using an excess of material and thereby of being heavier and more expensive than needed.

30 It is therefore an object of the present invention to provide a girder for reinforcing substantially horizontal structural members made of reinforced concrete, which is free

from said disadvantages. Another object of the present invention is to provide a method for connecting girders of the above-mentioned type and pillars, with the help of suitable short reinforcing members. These objects are achieved with a girder comprising at least one prefabricated truss and provided with lateral protrusions at its ends, said protrusions
5 being suitable for supporting short reinforcing members arranged aside and externally to the pillar, the short reinforcing members being intended to reinforce the connecting knot between girders and pillar and to provide continuity from bay to bay. The girders and the short reinforcing members may thus be placed very rapidly for the cast of concrete.

A first important advantage of the girder and the method according to the present
10 invention is that the mutual connection between the girders and the connection between the girders and the pillars may be carried out in a very short time and in a cheaper way with respect to the prior art. By using the girder and the method according to the present invention in fact it is no more necessary to insert any truss into the reinforcing members of the pillars, since the portion of the truss protruding from the flat component of the
15 girder is rapidly placed on the pillar and the short reinforcing members are arranged onto the lateral protrusions of the girder immediately after that, aside and externally to the reinforcing members of the pillar. The above-mentioned short reinforcing members may be e.g. portions of girders having a truss and not requiring the help of further supports in addition to the lateral protrusions of the girder according to the present
20 invention.

A second significant advantage of the girder and the method according to the present invention is that the girder may be a "low-profile" girder and the method may be used for connecting said low-profile girders according to the present invention to pillars and consolidating them by using concrete much more rapidly when the short reinforcing
25 members are preferably provided with an L-shaped profile suitable for containing the cast of concrete with no need for a suitable formwork.

Another important advantage of the girder and the method according to the present invention is that by arranging short reinforcing members aside the girders and the pillar, the number of members forming the reinforcing core of the girder is increased
30 in correspondence and proximate to the pillar, where the shearing actions are higher. In this way it is possible to use girders with trusses formed of bars having a reduced cross-

section, thus lightening the centre portions of the girders where reinforcing bars having a large cross-section are not necessary. Therefore a saving of material and a consequent cost reduction is achieved.

Further advantages and features of the girder and the method for its connection to girders of adjacent bays and pillars with the help of short reinforcing members according to the present invention will become clear to those skilled in the art from the following detailed description of some embodiments thereof with reference to the attached drawings, wherein:

- 10 - figure 1 is a perspective view of a first embodiment of the girder according to the present invention;
- figure 2 shows a second embodiment of the girder according to the present invention;
- figure 3 shows a third embodiment of the girder according to the present invention;
- 15 - figure 4 shows a fourth embodiment of the girder according to the present invention;
- figure 5 shows two girders according to the present invention and a secondary girder that are mounted on a pillar with the help of two short reinforcing members;
- 20 - figure 6 shows two girders according to the present invention that have a low-profile and are mounted on a pillar, only one short reinforcing member being shown; and
- figure 7 shows two girders according to another embodiment of the present invention mounted on a pillar.

25 Figure 1 shows one end of a girder 1 for reinforcing structural members made of reinforced concrete according to the invention. As shown in the figure, girder 1 comprises a truss 2. Truss 2 may be connected to an underlying flat component 3 being substantially parallel thereto. Flat component 3 shown in the figure is comprised of a horizontal steel sheet whose side edges 3a, 3b are usually parallel to each other. Flat
30 component 3 is preferably larger than truss 2 so that the ends of horizontal structural members, such as e.g. the so-called "predalles" plates, may be placed onto its side edges

3a, 3b and transversely arranged between girders 1, that are spaced apart and substantially parallel to each other, in order to make slabs or other building surfaces. It should be noted that girder 1 may also be free from the above-described flat component 3.

5 In the preferred embodiment shown in figure 1, truss 2 is longer than flat component 3 in order to protrude beyond its end 3c. The ends of truss 2 are provided with at least one horizontal profile 2a arranged transversely to girder 1 in order to prevent the girder from overturning to a side and to improve the strength of the connection between the girder and a reinforced concrete pillar once the cast of concrete
10 has been made and consolidated.

Truss 2 comprises a plurality of connecting bars 2b, which connect at least one upper longitudinal bar 2c to flat component 3 of girder 1 substantially parallel to each other. Moreover, truss 2 may comprise at least one lower longitudinal bar 2d contacting flat component 3 of girder 1.

15 According to the invention girder 1 is provided with at least one lateral protrusion 4, 5. In the preferred embodiment shown in figure 1 lateral protrusions 4, 5 are comprised of one bar transversely fixed to girder 1 under upper longitudinal bars 2c. These lateral protrusions 4, 5 are suitable for supporting short reinforcing members for connecting girders to pillars.

20 In an alternative embodiment shown in figure 2 lateral protrusions 4, 5 are formed of at least one bar fixed transversely to girder 1 underneath end 3c of flat component 3 of girder 1. The bar must be longer than the width of flat component 3 in order to protrude from both its side edges 3a, 3b.

In a third embodiment shown in figure 3, lateral protrusions 4, 5 are flat horizontal
25 fins, which are fixed coplanar to lateral edges 3a, 3b of flat component 3 at its end 3c.

Figure 4 shows a fourth embodiment of girder 1 according to the present invention. Girder 1 is provided with a least one intermediate longitudinal bar 2e, which is arranged between upper longitudinal bars 2c and lower longitudinal bars 2d and is substantially parallel thereto. Intermediate longitudinal bars 2e are provided with a
30 horizontal profile 2a that is arranged transversely to girder 1. The horizontal profile has an anti-overturning function and improves the strength of the connection between girder

- 6 -

pillar once the cast of concrete has been carried out. Moreover, girder 1 shown in figure 4 is provided with a concave profile 6, having a concavity facing upwards, that is fixed under truss 2. Intermediate longitudinal bars 2e are longer than concave profile 6 and their ends are suitable for being placed onto the pillars. On the contrary, lower longitudinal bars 2d are not longer than concave profile 6 and are contained inside it. In this way girder 1 shown in figure 4 is suitable for being placed in a configuration that has a low-profile with respect to the height of the pillar, wherein lower longitudinal bars 2d and concave profile 6 fixed thereto are arranged underneath the plane where the girder sits on the pillar. The ends 6c of concave profile 6 suitable for being arranged in contact with the side wall of the pillar, so that the cast of concrete may be contained in the cavity of concave profile 6 itself with no need for formwork. Moreover, concave profile 6 may have such a height that its edges 6a, 6b are at the same level of the plane where the girder sits on the pillar and are suitable for supporting the ends of horizontal structural members, such as for example "predalles" plates.

Figure 5 shows a reinforced concrete pillar 7 with two girders 1, 1', substantially arranged in the same direction, for reinforcing structural members made of reinforced concrete according to the method of the present invention.

The method, intended to make a structure continuous from bay to bay, comprises the steps of:

- arranging the ends of two girders 1, 1' onto the upper end of a pillar 7, from which substantially vertically reinforcing members 8 protrude,
- arranging at least one short reinforcing member 9, 10 along the direction of girders 1, 1' in correspondence to pillar 7; and
- carrying out a cast of concrete.

In particular, in the method according to the invention short reinforcing members 9, 10 are arranged parallel to girders 1, 1' externally to reinforcing members 8 of pillar 7. Reinforcing members 9, 10 may be supported by lateral protrusions 4, 5, 4', 5' that can be associated with the girders as described above.

It should be noted that this method allows to overcome the technical prejudice that in mixed structures, as well as in reinforced concrete structures, possible short reinforcing members are internally arranged among the reinforcing members 8 of the

pillars. The applicant in fact has surprisingly found that it is possible to make a continuous optimal connection between the girders of a structure in correspondence to the pillars by means of short reinforcing members set aside, thus making girders that are larger than the pillars. Girders being larger than pillars do not jeopardize the structural performances of the structure at all. Moreover, it should be noted that the method according to the invention is compliant with the present Italian standard, since this provides that the girder may be larger than the pillar and protrude up to one third of its width on both sides of the pillar.

As shown in figure 5, lateral protrusions 4, 5, 4', 5' of two girders 1, 1' arranged on a pillar 7 may support short reinforcing members 9, 10. Short reinforcing members 9, 10 shown in the figure are portions of girders formed of a truss hung to lateral protrusions 4, 5, 4', 5' of girders 1, 1'. As it may be noted in figure 5, it is possible to use short reinforcing members 9, 10 having such a height that, once hung to lateral protrusions 4, 5, 4', 5' of girders 1, 1', they allow to place a secondary girder 11 onto pillar 7. In particular it is possible to insert the lower longitudinal bars of the secondary girder under short reinforcing members 9, 10.

The ends 3c of possible flat members 3, 3', underlying trusses 2, 2' forming girders 1, 1', preferably contact the lateral surface of pillar 7 in order to allow to carry out the cast of concrete without a formwork underlying the girders, thus preventing concrete from passing between flat components 3, 3' and the pillar.

In figure 6 an alternative embodiment of the connecting method according to the present invention is shown. It should be noted that for the sake of clarity only two girders 1, 1', one pillar 7 and a single short reinforcing member 10 are shown, whereas no secondary girder is shown. Girders 1, 1' are of the low-profile type shown in figure 4 and sit on pillar 7, the concave profile 6 contacting the lateral surface of pillar 7 itself so that there is no need for any formwork for casting concrete. As shown in the figure, it is possible to hang short reinforcing members 10 to lateral protrusions 4, 5, 4', 5', the short reinforcing members being formed of a truss provided with a centre portion having a wide opening in order to allow to insert and place a secondary girder. Moreover, as shown in the figure, short reinforcing member 10 may be provided with a shaped concave profile 12 suitable for being arranged in contact with concave profiles 6, 6' of

girders 1, 1' and with pillar 7 in order to contain the cast of concrete without the help of a formwork.

In figure 7 a further alternative embodiment of the connecting method according to the present invention is shown, by using girders 1, 1' of the type shown in figure 3. In
5 this case short reinforcing members 9, 10 may be externally arranged aside girders 1, 1' and reinforcing members 8 of pillar 7, the short reinforcing members being placed on lateral protrusions 4, 5, 4', 5' formed of horizontal fins.

Still referring to figures 5, 6 and 7 it should be noted that girders 1, 1' of the invention do not disturb and are not encumbered by the thick reinforcing members 8 of
10 a pillar 7, thus anyway allowing to make a solid connection between girders and pillar thanks to short reinforcing members 9, 10 supported by lateral protrusions 4, 5, 4', 5'.

It should also be noted that although the so-called "predalles" plates are immediately placed onto girders 1, 1', reinforcing members 9, 10 may be externally arranged aside girders 1, 1' and pillar 7, thus being directly arranged on the "predalles"
15 plates themselves without the help of lateral supporting protrusions 4, 5, 4', 5'.

It is clear that the above described and illustrated embodiments of the girder and the method for connecting girders to pillars with the help of short reinforcing members according to the invention are only examples susceptible of numerous variations. In particular, the girder could be other than straight, e.g. arc-shaped, in order to form
20 architectural vaults.

CLAIMS

1. A girder (1) for reinforcing structural members made of reinforced concrete, comprising at least one truss (2), characterized in that proximate to each end thereof the girder (1) is provided with at least one lateral protrusion (4, 5) transversely arranged with respect thereto.

2. A girder (1) according to claim 1, characterized in that each of the lateral protrusions (4, 5) is formed of at least one bar transversely fixed underneath the girder (1) and protruding from both sides thereof.

3. A girder (1) according to claim 1, characterized in that the truss (2) comprises at least one upper longitudinal bar (2c) to which a bar protruding from both sides of the girder (1) is fixed, the bar being arranged transversely to the girder (1) and forming the lateral protrusions (4, 5).

4. A girder (1) according to one of the previous claims, characterized in that at least one flat component (3) is arranged underneath the truss (2) substantially parallel thereto.

5. A girder (1) according to the previous claim, characterized in that the truss (2) is longer than the flat component (3) and protrudes beyond the ends (3c) of the latter.

6. A girder (1) according to claim 4 or 5, characterized in that the lateral protrusions (4, 5) are flat horizontal fins laterally fixed at the ends (3c) of the flat component (3) of the girder (1) and coplanar to the flat component (3).

7. A girder (1) according to one of claims 4 to 6, characterized in that the truss (2) comprises a plurality of connecting bars (2b) that connect at least one upper longitudinal bar (2c) to the flat component (3) of the girder (1) substantially parallel to each other.

8. A girder (1) according to one of claims 4 to 7, characterized in that the truss (2) comprises at least one lower longitudinal bar (2d) contacting its flat component (3).

9. A girder (1) according to claim 1 or 3, characterized in that a concave profile (6) having a concavity facing upwards is fixed underneath the truss (2)

substantially parallel thereto and the truss (2) comprises at least one upper longitudinal bar (2c) and at least one lower longitudinal bar (2d) between which an intermediate longitudinal bar (2e) is arranged substantially parallel thereto, the intermediate longitudinal bars (2e) being longer than the concave profile (6) and their ends being
5 suitable for being placed on pillars.

10. A girder (1) according to the previous claim, characterized in that its ends are provided with at least one horizontal profile (2a) arranged transversely to the girder (1) itself.

11. A method for connecting two girders (1, 1') and one pillar (7) for
10 reinforcing structural elements made of reinforced concrete, each girder (1, 1') being provided with at least one truss (2, 2'), said method comprising the steps of:

- placing one end of the truss (2, 2') of each of the two girders (1, 1') onto the upper end of the pillar (7) from which reinforcing members (8) protrude;
 - arranging at least one short reinforcing member (9, 10) in correspondence to the
15 pillar (7) along the direction of the girders (1, 1'); and
 - carrying out a cast of concrete,
- characterized in that the short reinforcing members (9, 10) are arranged externally to the reinforcing members (8) of the pillar (7) and the girders (1, 1'), aside and substantially parallel to the girders (1, 1').

20 12. A method according to the previous claim, characterized in that the girders (1, 1') are girders according to one of claims 1 to 10 and the short reinforcing members (9, 10) are supported by the lateral protrusions (4, 5, 4', 5') of the girders (1, 1').

25 13. A method according to the previous claim, characterized in that the short reinforcing members (9, 10) are hung to the lateral protrusions (4, 5, 4', 5') of the girders (1, 1').

30 14. A method according to the previous claim, characterized in that the short reinforcing members (9, 10) have such a height that, once the reinforcing members are hung to the lateral protrusions (4, 5, 4', 5') of the girders (1, 1'), they allow to place a secondary girder (11), having lower longitudinal bars, onto the pillar (7) by inserting said lower longitudinal bars under the short reinforcing members (9, 10).

15. A method according to one of claims 11 to 13, characterized in that the girders (1, 1') are girders according to claim 9 and the short reinforcing members (9, 10) are comprised of a truss provided with a centre portion having a wide opening for allowing to insert and place a secondary girder onto the pillar (7).

5 16. A method according to the previous claim, characterized in that the short reinforcing members (9, 10) are provided with a shaped concave profile (12) suitable for being arranged in contact with the concave profiles (6, 6') of the girders (1, 1') and the pillar (7) in order to contain the cast of concrete without the help of a formwork.

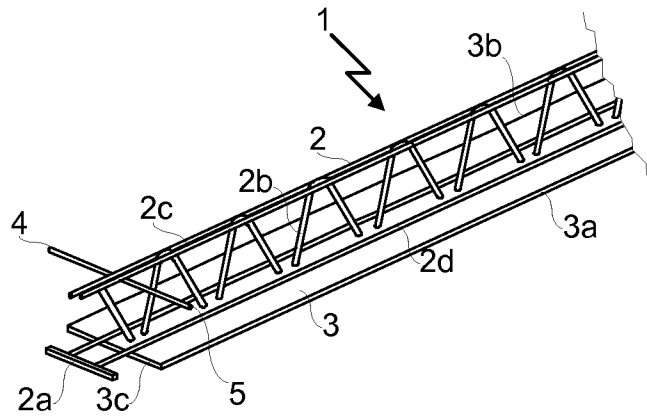

Fig.1

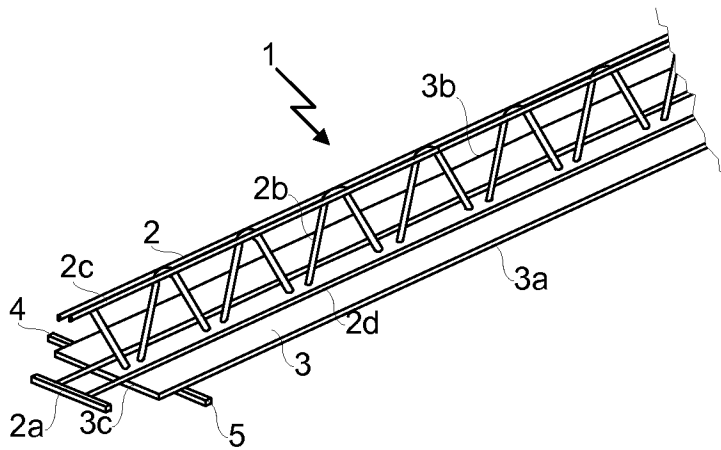

Fig.2

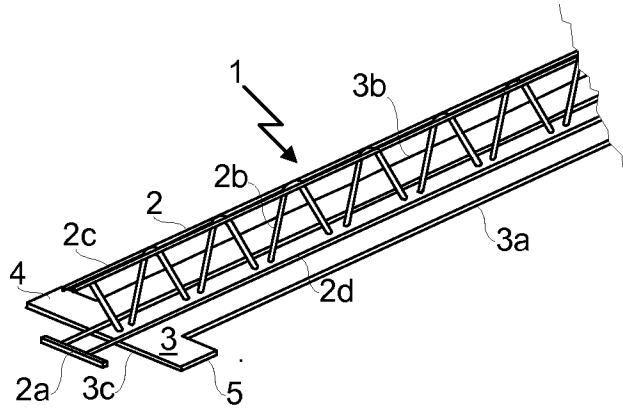

Fig.3

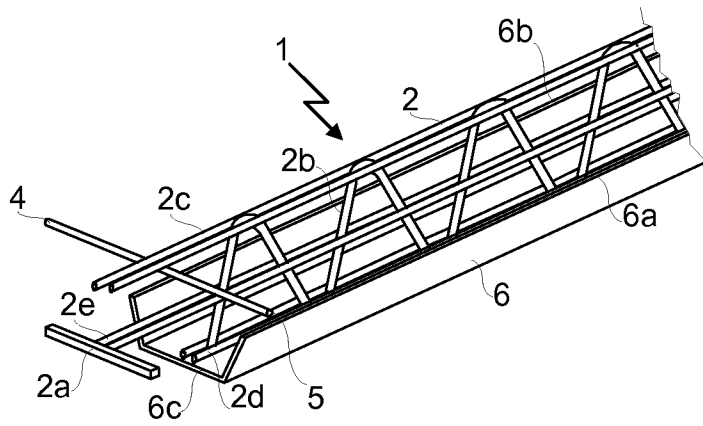

Fig.4

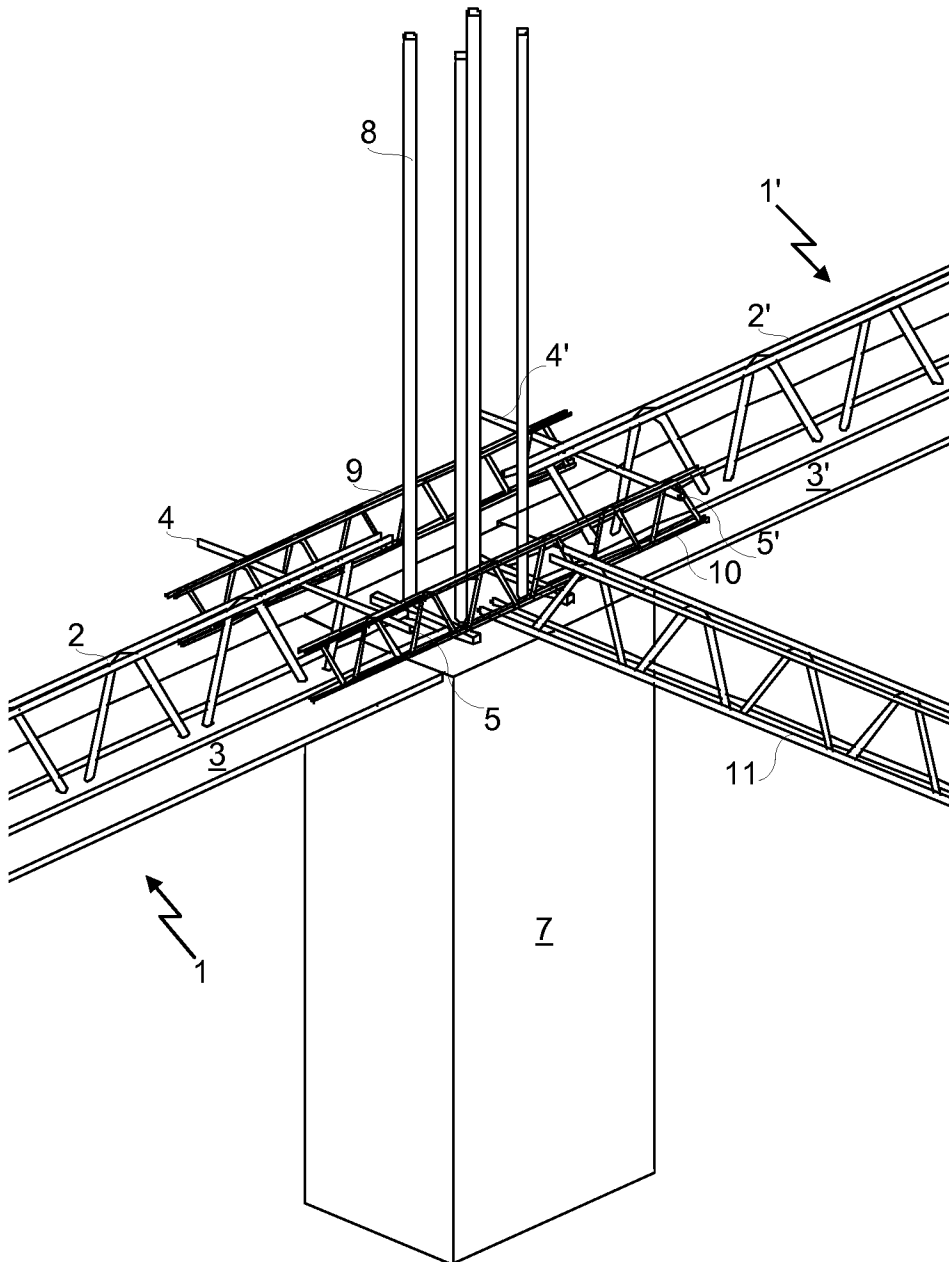

Fig. 5

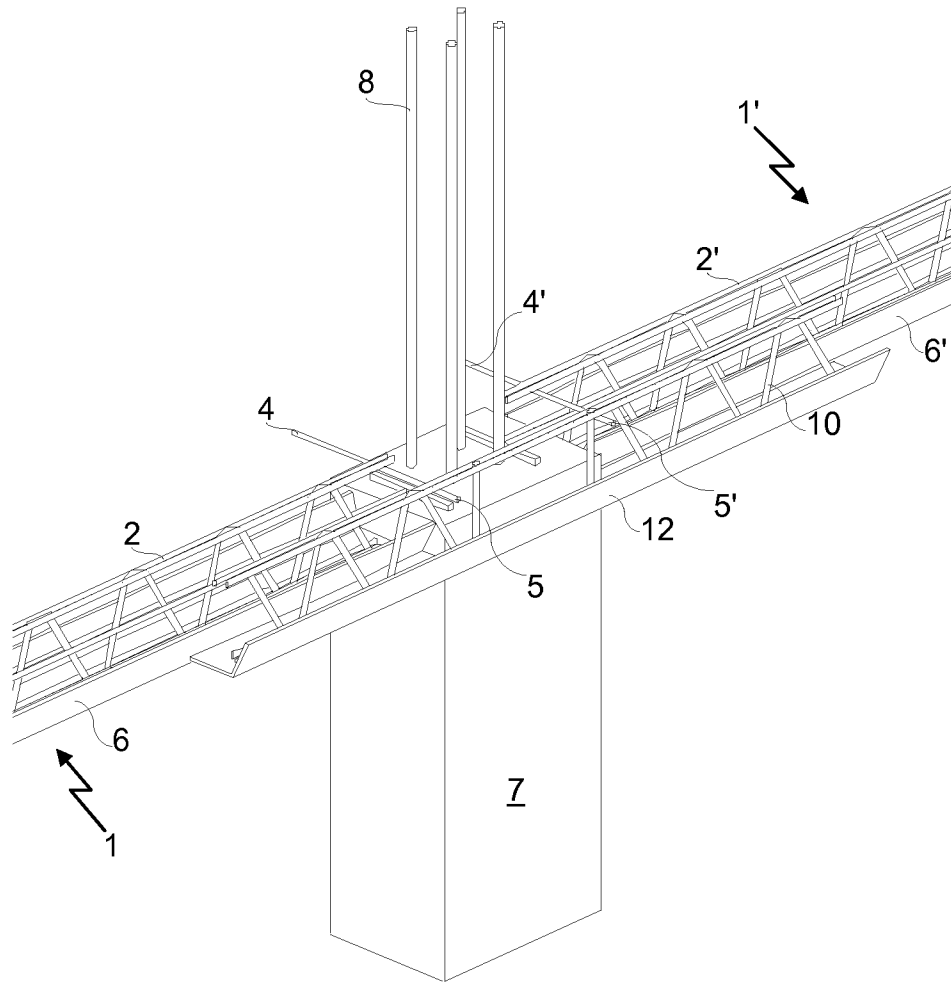

Fig. 6

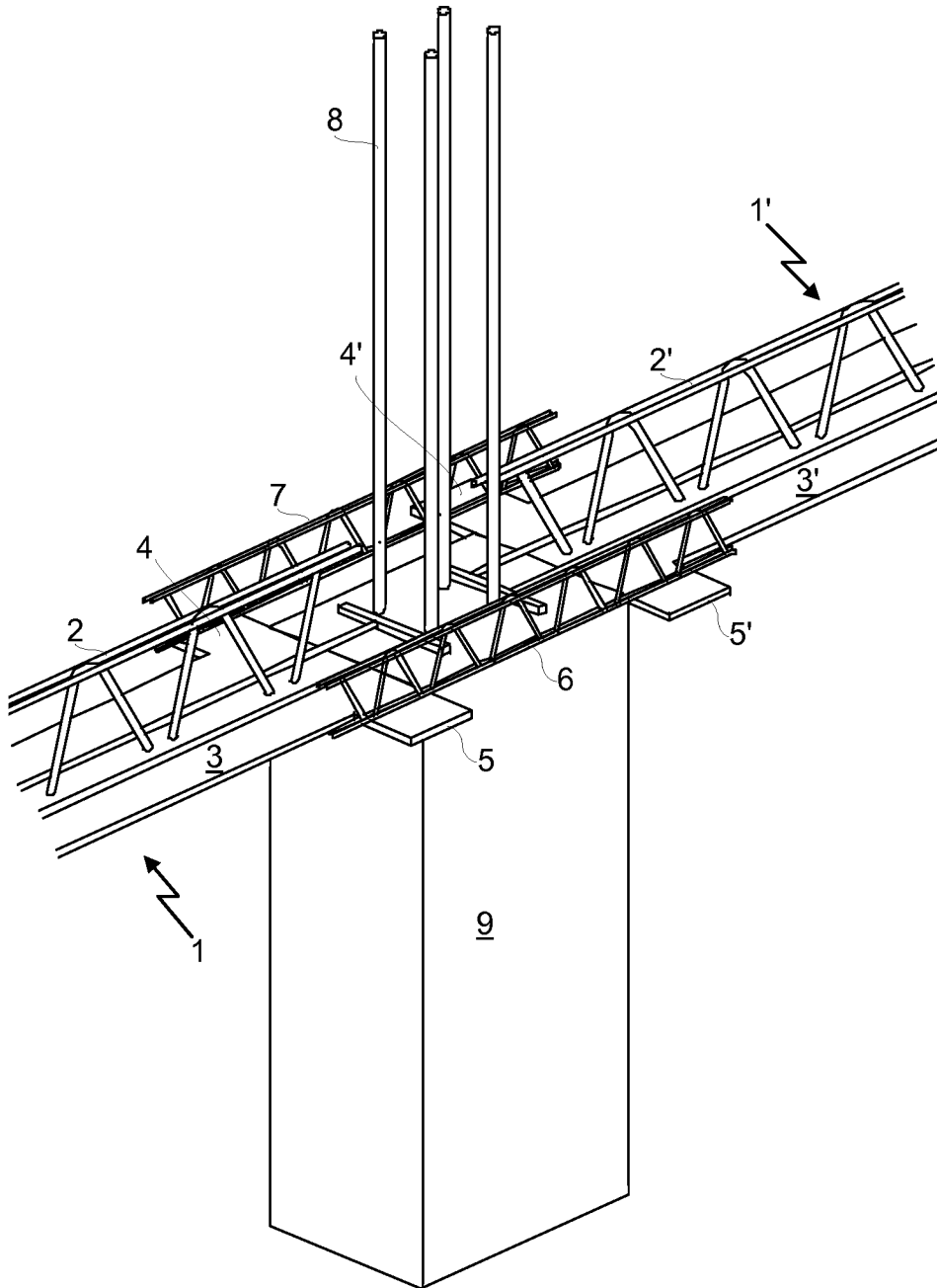

Fig.7

INTERNATIONAL SEARCH REPORT

International application No
PCT/EP2008/057760

A. CLASSIFICATION OF SUBJECT MATTER

INV. E04B1/21 E04B5/38 E04C3/294 E04C5/065

According to International Patent Classification (IPC) or to both national classification and IPC

B. FIELDS SEARCHED

Minimum documentation searched (classification system followed by classification symbols)
E04B E04C

Documentation searched other than minimum documentation to the extent that such documents are included in the fields searched

Electronic data base consulted during the international search (name of data base and, where practical, search terms used)

EPO-Internal

C. DOCUMENTS CONSIDERED TO BE RELEVANT

Category*	Citation of document, with indication, where appropriate, of the relevant passages	Relevant to claim No.
X	US 5 235 791 A (YAGUCHI HIDE [JP]) 17 August 1993 (1993-08-17)	1,2,4,5, 7,8
Y	column 1, line 6 - line 10 column 2, line 1 - line 9 column 6, line 42 - column 7, line 2; claims 1,2; figures 1,3,4,8	6,9,10
X	DE 25 01 758 A1 (LEONE SALVATORE) 15 April 1976 (1976-04-15)	1,2,4,5, 7,8
Y	page 2, paragraph 1 page 5, paragraph 3 - page 6, paragraph 3; claim 1; figure 1	6,9,10
X	WO 93/15287 A (BUCHER FRANZ [AT]) 5 August 1993 (1993-08-05)	1-4,7,8
Y	page 1, line 1 - line 9 page 3, line 26 - line 32; claim 1; figures 1,2	6,9,10
	----- -/--	

Further documents are listed in the continuation of Box C.

See patent family annex.

* Special categories of cited documents:

- *A* document defining the general state of the art which is not considered to be of particular relevance
- *E* earlier document but published on or after the international filing date
- *L* document which may throw doubts on priority claim(s) or which is cited to establish the publication date of another citation or other special reason (as specified)
- *O* document referring to an oral disclosure, use, exhibition or other means
- *P* document published prior to the international filing date but later than the priority date claimed

- *T* later document published after the international filing date or priority date and not in conflict with the application but cited to understand the principle or theory underlying the invention
- *X* document of particular relevance; the claimed invention cannot be considered novel or cannot be considered to involve an inventive step when the document is taken alone
- *Y* document of particular relevance; the claimed invention cannot be considered to involve an inventive step when the document is combined with one or more other such documents, such combination being obvious to a person skilled in the art.
- *&* document member of the same patent family

Date of the actual completion of the international search

16 September 2008

Date of mailing of the international search report

28/10/2008

Name and mailing address of the ISA/

European Patent Office, P.B. 5818 Patentlaan 2
NL - 2280 HV Rijswijk
Tel. (+31-70) 340-2040,
Fax: (+31-70) 340-3016

Authorized officer

Giannakou, Evangelia

INTERNATIONAL SEARCH REPORT

International application No

PCT/EP2008/057760

C(Continuation). DOCUMENTS CONSIDERED TO BE RELEVANT

Category*	Citation of document, with indication, where appropriate, of the relevant passages	Relevant to claim No.
X	WO 98/21427 A (NEMIS ESTABLISHMENT [LI]) 22 May 1998 (1998-05-22)	1-3
Y	page 1, line 1 - line 7 page 4, line 5 - page 5, line 25; claims 1,4; figures 1,2,13	6,9,10
Y	AT 331 016 B (KATZENBERGER HELMUT [AT]) 26 July 1976 (1976-07-26) page 2, line 40 - line 49; figures 1,2	6
Y	US 3 158 925 A (EDGE HELEN M) 1 December 1964 (1964-12-01) column 2, line 21 - line 33; figure 1	6
Y	DE 11 93 224 B (RHEINBAU GMBH) 20 May 1965 (1965-05-20) column 2, line 18 - line 37; figures 1,10	9,10
Y	EP 0 870 883 A (GRUPPO EFFE 2 SPA [IT]) 14 October 1998 (1998-10-14) column 2, line 55 - column 3, line 31; claim 1; figures 1,4	9,10
X	WO 2007/030836 A (DO DUC THANG [VN]) 15 March 2007 (2007-03-15)	11
Y	page 10, paragraph 2 - paragraph 4; figure 9	12-16
Y	EP 0 790 364 A (JIMENEZ SANCHEZ JAIME ENRIQUE [ES]) 20 August 1997 (1997-08-20) column 1, line 5 - line 15 column 2, line 48 - line 53 column 3, line 30 - line 33 column 4, line 41 - column 5, line 2; figures 5,9	11-16
Y	EP 1 431 469 A (LEONE SALVATORE [IT] PEZZI PAOLA [IT]; LEONE UBALDO [IT]; LEONE LUCIO) 23 June 2004 (2004-06-23) paragraph [0044]; figures 6,7	11-16
A	FR 2 491 977 A (SARET [FR]) 16 April 1982 (1982-04-16) page 6, line 9 - page 7, line 34; figures 2,3	11-16
A	US 2007/137133 A1 (BARTELS MICHAEL JACOBUS G [NL]) 21 June 2007 (2007-06-21) paragraph [0089] - paragraph [0093]; figures 9,10	11-16

INTERNATIONAL SEARCH REPORT

Information on patent family members

International application No
PCT/EP2008/057760

Patent document cited in search report	Publication date	Patent family member(s)	Publication date
US 5235791	A	17-08-1993 NONE	
DE 2501758	A1	15-04-1976 IT US	1022321 B 3964217 A 20-03-1978 22-06-1976
WO 9315287	A	05-08-1993 AU DE DE SK	3337093 A 9320554 U1 9400388 U1 87694 A3 01-09-1993 15-09-1994 31-03-1994 09-11-1994
WO 9821427	A	22-05-1998 CZ	9802432 A3 16-12-1998
AT 331016	B	26-07-1976 ES	226930 Y 16-11-1978
US 3158925	A	01-12-1964 NONE	
DE 1193224	B	20-05-1965 NONE	
EP 0870883	A	14-10-1998 HR IT	980200 A2 VI970056 A1 28-02-1999 10-07-1997
WO 2007030836	A	15-03-2007 NONE	
EP 0790364	A	20-08-1997 AU CN ES WO HU PL TR	5111196 A 1164881 A 2133202 A1 9709494 A1 9702115 A2 319949 A1 9700346 T1 27-03-1997 12-11-1997 01-09-1999 13-03-1997 28-04-1998 01-09-1997 21-08-1997
EP 1431469	A	23-06-2004 IT	UD20020265 A1 20-03-2003
FR 2491977	A	16-04-1982 NONE	
US 2007137133	A1	21-06-2007 NONE	