



(86) Date de dépôt PCT/PCT Filing Date: 2011/11/15
 (87) Date publication PCT/PCT Publication Date: 2012/05/24
 (85) Entrée phase nationale/National Entry: 2013/05/09
 (86) N° demande PCT/PCT Application No.: US 2011/060860
 (87) N° publication PCT/PCT Publication No.: 2012/068166
 (30) Priorité/Priority: 2010/11/15 (US61/413,895)

(51) Cl.Int./Int.Cl. *A61M 5/14* (2006.01),
A61B 17/03 (2006.01), *A61B 17/34* (2006.01),
A61M 25/09 (2006.01), *A61M 5/178* (2006.01)
 (71) Demandeur/Applicant:
 VASCULAR INSIGHTS LLC, US
 (72) Inventeurs/Inventors:
 TAL, MICHAEL G., US;
 MARANO, JOHN P., US
 (74) Agent: SMART & BIGGAR

(54) Titre : DISPOSITIFS ET METHODES DE TRAITEMENT VASCULAIRE
 (54) Title: VASCULAR TREATMENT DEVICES AND METHODS

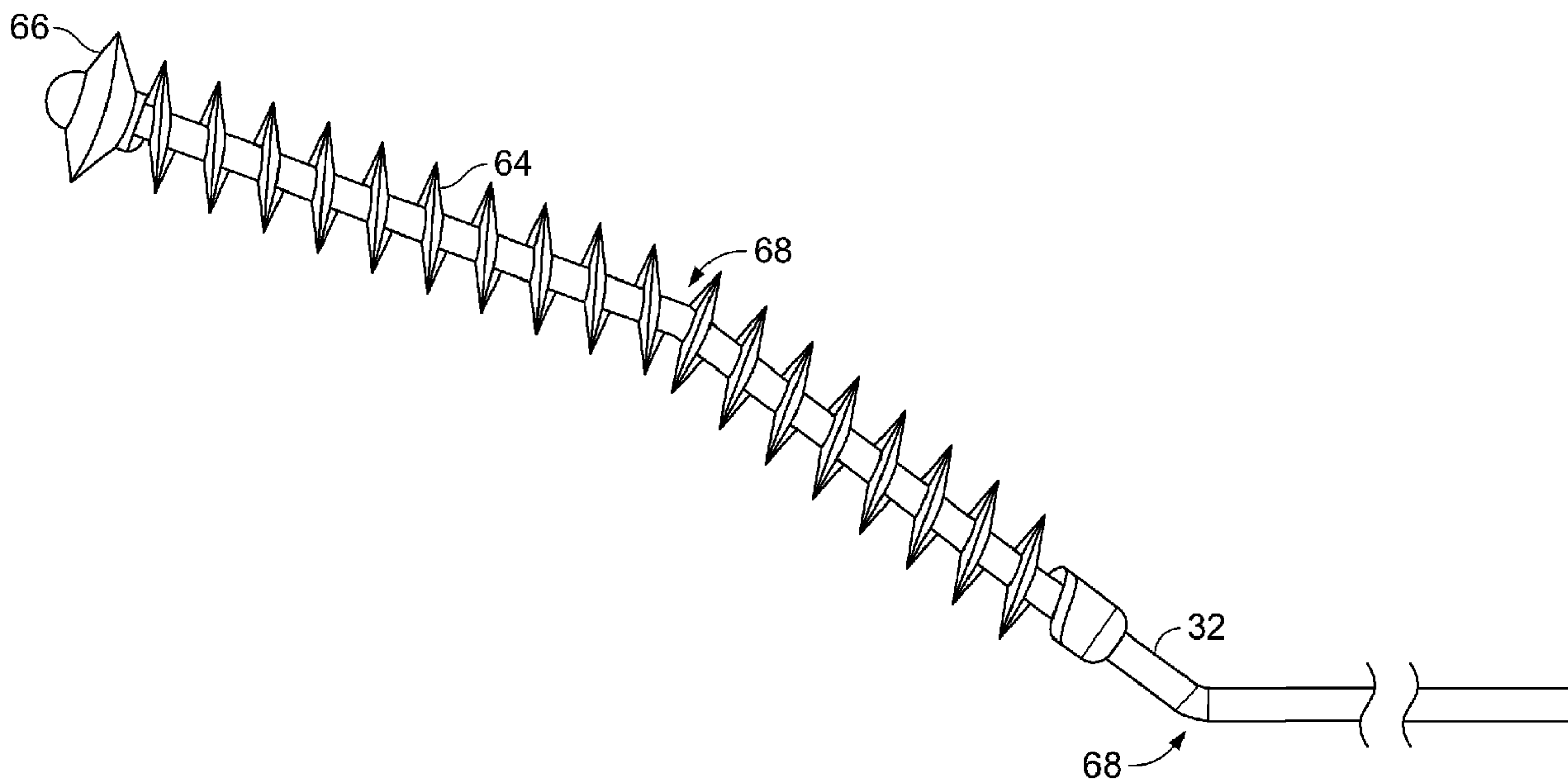

Figure 3A

(57) **Abrégé/Abstract:**

An apparatus for performing a vascular treatment includes an intraluminal member that is controllably moved during the vascular treatment. The intraluminal member of the vascular treatment device can be connected to a motor. The intraluminal member may be configured to retain endothelium during the vascular treatment procedure.



(12) INTERNATIONAL APPLICATION PUBLISHED UNDER THE PATENT COOPERATION TREATY (PCT)

(19) World Intellectual Property
Organization
International Bureau(10) International Publication Number
WO 2012/068166 A3(43) International Publication Date
24 May 2012 (24.05.2012)

(51) International Patent Classification:

A61M 5/14 (2006.01) *A61B 17/03* (2006.01)
A61M 25/09 (2006.01) *A61M 5/178* (2006.01)
A61B 17/34 (2006.01)

(21) International Application Number:

PCT/US2011/060860

(22) International Filing Date:

15 November 2011 (15.11.2011)

(25) Filing Language:

English

(26) Publication Language:

English

(30) Priority Data:

61/413,895 15 November 2010 (15.11.2010) US

(71) Applicant (for all designated States except US): VASCULAR INSIGHTS LLC [US/US]; 395 Boston Post Road, Madison, CT 06443 (US).

(72) Inventors; and

(75) Inventors/Applicants (for US only): **TAL, Michael, G.** [US/US]; 395 Boston Post Road, Woodbridge, CT (US).
MARANO, John, P. [US/US]; 395 Boston Post Road, Madison, CT (US).

(74) Agent: **ARNO, Thomas, R.**; Knobbe Martens Olson & Bear LLP, 2040 Main Street, 14th Floor, Irvine, CA 92614 (US).

(81) Designated States (unless otherwise indicated, for every kind of national protection available): AE, AG, AL, AM,

AO, AT, AU, AZ, BA, BB, BG, BH, BR, BW, BY, BZ, CA, CH, CL, CN, CO, CR, CU, CZ, DE, DK, DM, DO, DZ, EC, EE, EG, ES, FI, GB, GD, GE, GH, GM, GT, HN, HR, HU, ID, IL, IN, IS, JP, KE, KG, KM, KN, KP, KR, KZ, LA, LC, LK, LR, LS, LT, LU, LY, MA, MD, ME, MG, MK, MN, MW, MX, MY, MZ, NA, NG, NI, NO, NZ, OM, PE, PG, PH, PL, PT, QA, RO, RS, RU, RW, SC, SD, SE, SG, SK, SL, SM, ST, SV, SY, TH, TJ, TM, TN, TR, TT, TZ, UA, UG, US, UZ, VC, VN, ZA, ZM, ZW.

(84) Designated States (unless otherwise indicated, for every kind of regional protection available): ARIPO (BW, GH, GM, KE, LR, LS, MW, MZ, NA, RW, SD, SL, SZ, TZ, UG, ZM, ZW), Eurasian (AM, AZ, BY, KG, KZ, MD, RU, TJ, TM), European (AL, AT, BE, BG, CH, CY, CZ, DE, DK, EE, ES, FI, FR, GB, GR, HR, HU, IE, IS, IT, LT, LU, LV, MC, MK, MT, NL, NO, PL, PT, RO, RS, SE, SI, SK, SM, TR), OAPI (BF, BJ, CF, CG, CI, CM, GA, GN, GQ, GW, ML, MR, NE, SN, TD, TG).

Published:

- with international search report (Art. 21(3))
- before the expiration of the time limit for amending the claims and to be republished in the event of receipt of amendments (Rule 48.2(h))

(88) Date of publication of the international search report:

2 August 2012

(54) Title: VASCULAR TREATMENT DEVICES AND METHODS

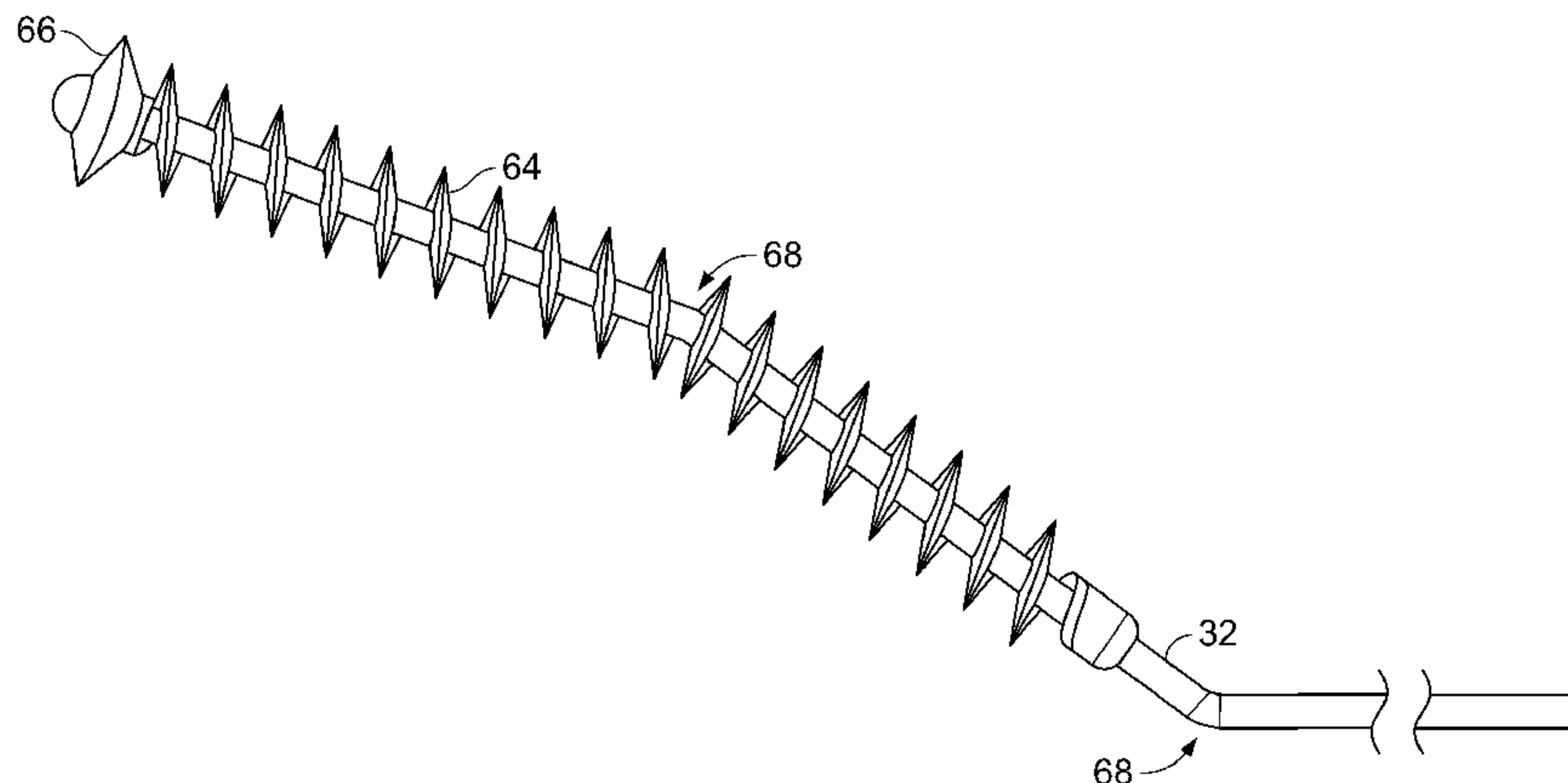

Figure 3A

(57) Abstract: An apparatus for performing a vascular treatment includes an intraluminal member that is controllably moved during the vascular treatment. The intraluminal member of the vascular treatment device can be connected to a motor. The intraluminal member may be configured to retain endothelium during the vascular treatment procedure.



WO 2012/068166 A3

VASCULAR TREATMENT DEVICES AND METHODS

CROSS-REFERENCE TO RELATED APPLICATIONS

[0001] This application claims the benefit of U.S. Provisional Application No. 61/413,895, filed on November 15, 2010, the disclosure of which is hereby incorporated by reference in its entirety.

BACKGROUND OF THE INVENTION

Field of the Invention

[0002] This specification relates to the field of vascular treatment.

Description of the Related Art

[0003] Sclerotherapy can be used to treat blood vessels, blood vessel malformations, and similar problems in other body systems, such as the lymphatic system, and has been used in various forms for over 150 years. In its more modern form, sclerotherapy has been used since the 1960's, in Europe, for treating various vein conditions such as; varicose veins, reticular veins, spider veins of the leg, and also some fine facial veins.

[0004] Sclerotherapy can be used to treat these conditions by instigating vascular fibrosis and obliteration in response to irreversible endothelial cellular destruction and exposure of the underlying subendothelial cell layer. This destruction is usually caused by the injection of a sclerosant into the vein. However, if the injected sclerosant is too weak, there may be no endothelial injury at all. If the sclerosant is a little stronger, the varicose vessel is damaged, but recanalization occurs and an incompetent pathway for retrograde blood flow persists. Finally, if the injected sclerosant is too strong, the varicose vessel endothelium is destroyed, but adjacent vessels that are not targeted for treatment may also be damaged by the sclerosant.

[0005] The requirement for an ideal strength of the sclerosant is complicated by the constant flow of blood through the vein that is being treated. This flow simultaneously dilutes, and thereby weakens, the sclerosant, while also transporting the sclerosant to other parts of the vascular system.

[0006] Thus, improved methods and devices for treating the vascular system are desired.

SUMMARY OF THE INVENTION

[0007] In one embodiment, a vascular treatment apparatus comprises an elongated intraluminal member shaped and dimensioned for passage through blood vessels of a subject. The intraluminal member may include a proximal end and a distal end, wherein the distal end comprises a vein wall disruptor. The vein wall disruptor may be configured to scrape tissue off of the inner wall of a blood vessel, and retain that tissue on the disruptor during use.

[0008] In another embodiment, a vascular treatment apparatus comprises an elongated intraluminal member shaped and dimensioned for passage through blood vessels of a subject, the intraluminal member including a proximal end and a distal end, wherein the distal end comprises a vein wall disruptor. The vein wall disruptor is configured to scrape tissue off of the inner wall of a blood vessel, and comprises structures therein forming tissue storing regions. The structures may be cavities or through holes.

[0009] In some embodiments, these apparatus may comprise a source of sclerosant and a fluid channel between the source of sclerosant and the distal end of the elongated intraluminal member.

[0010] In another embodiment, a vascular treatment method comprises advancing an elongated intraluminal member from an access site and into the vein, damaging the inner vessel wall by performing a defined movement of the portion of the intraluminal member against the vein's endothelium. The damaging comprises removing endothelium tissue from the inner vessel wall and retaining endothelium tissue on the portion of the intraluminal member while performing the defined movement.

[0011] In another embodiment, a method for permanently occluding a vein through the combined disruption of a vein vessel wall and application of a sclerosant comprises advancing an elongated intraluminal member from an access site and into the vein, wherein the intraluminal member has a portion thereof configured to produce damage to the inner vessel wall of the vein under user control when performing a defined movement, damaging the inner vessel wall by performing the defined movement of the portion of the intraluminal member against the vein's endothelium, injecting sclerosant

into the vein and onto the damaged inner vessel wall, observing sclerosant exiting from the access site, and stopping injection of sclerosant in response to the observing.

[0012] In another embodiment, a method for permanently occluding a vein through the combined disruption of a vein vessel wall and application of a sclerosant comprises orienting a subject with at least one extremity below their head, advancing an elongated intraluminal member from an access site and into a vein in the at least one extremity, wherein the intraluminal member has a portion thereof configured to produce damage to the inner vessel wall of the vein under user control when performing a defined movement, re-orienting the subject with the at least one extremity approximately level with or slightly above their head, damaging the inner vessel wall by performing the defined movement of the portion of the intraluminal member against the vein's endothelium, and injecting sclerosant into the vein and onto the damaged inner vessel wall. The extremity may be an arm or a leg.

[0013] The foregoing is a summary and thus contains, by necessity, simplifications, generalization, and omissions of detail; consequently, those skilled in the art will appreciate that the summary is illustrative only and is not intended to be in any way limiting. Other aspects, features, and advantages of the devices and/or processes and/or other subject matter described herein will become apparent in the teachings set forth herein. The summary is provided to introduce a selection of concepts in a simplified form that are further described below in the Detailed Description. This summary is not intended to identify key features or essential features of the claimed subject matter, nor is it intended to be used as an aid in determining the scope of the claimed subject matter.

BRIEF DESCRIPTION OF THE DRAWINGS

[0014] FIGURE 1 shows an embodiment of an assembly of a vascular treatment device.

[0015] FIGURE 2A illustrates a longitudinal cross-sectional view of the embodiment illustrated in Figure 1.

[0016] FIGURE 2B illustrates the distal ends of the wire and sheath of Figure 2A.

[0017] FIGURE 2C illustrates the distal ends of the wire and sheath of Figure 2A with the distal end of the wire extending out from the end of the sheath.

[0018] Figure 3A illustrates an embodiment of a distal end of a wire with multiple sharp edges along an extended length.

[0019] Figure 3B illustrates an embodiment of a distal wire end having a roughened surface and cavities formed therein.

[0020] Figure 3C illustrates an embodiment of a distal wire tip having scraping projections and cavities formed as through holes.

[0021] Figure 4 is flow chart of a first vascular treatment method.

[0022] Figure 5 is a flow chart of a second vascular treatment method.

DETAILED DESCRIPTION OF THE PREFERRED EMBODIMENT

[0023] The following description and examples illustrate preferred embodiments of the present invention in detail. Those of skill in the art will recognize that there are numerous variations and modifications of this invention that are encompassed by its scope. Accordingly, the description of a preferred embodiment should not be deemed to limit the scope of the present invention. In this description, reference is made to the drawings wherein like parts are designated with like numerals throughout.

[0024] Figure 1 depicts a perspective view of one embodiment of exemplary components of a vascular treatment device 10. These components can be configured to provide a range of functionalities to the vascular treatment device 10. In some embodiments, a vascular treatment device 10 can include features configured for stimulating vascular ablation, such as, for example, an intraluminal member 22, a motorized drive system, including, for example, a motor, and/or control features and/or features configured for delivering liquid sclerosant. In some embodiments described further below, the intraluminal member comprises a wire surrounded by a sheath, and the wire is rotatable within the sheath. The space between the sheath and the wire can be used as a passage to inject sclerosant as the wire rotates, and the distal end of the wire forms a vein wall disruptor.

[0025] In general, the vascular treatment device 10 of Figure 1 is utilized by introducing the intraluminal member into a vein of a subject, where the vein is to be ablated in a treatment for varicose veins for example. The distal end of the wire is extended from the distal end of the sheath, and the wire is rotated or otherwise moved to damage the endothelium lining the inside surface of the vein. Sclerosant is also injected

to the region of damage through the sheath that forms an outer portion of the intraluminal member 22. The combination of endothelium damage plus the sclerosant provides a highly effective vascular ablation procedure with a minimum amount of injected sclerosant.

[0026] As depicted in Figure 1, a vascular treatment device can include a handle 12 and a cartridge 14. As explained below in greater detail, each of the handle 12 and cartridge 14 can include features configured for stimulating vascular ablation and/or for delivering liquid sclerosant. In one embodiment, and as depicted in Figure 1, the handle 12 and the cartridge 14 can comprise separate pieces. In another embodiment, a handle 12 and a cartridge 14 can comprise an integrated component. A person of skill in the art will recognize that the present disclosure is not limited to a specific configuration of the handle 12 and cartridge 14 but broadly includes the range of functions and uses of a vascular therapy device.

[0027] As further depicted in Figure 1, the cartridge 14 can be, for example, sized and shaped to engagingly connect to the handle 12. In one embodiment, and as shown in Figure 1, this engaging connection can be achieved by fitting features of the handle 12 to features of the cartridge 14.

[0028] Figure 2 depicts a side cross-section view of the vascular treatment device 10 of Figure 1. The vascular treatment device 10 depicted in Figure 2 comprises the same features discussed in relation to Figure 1. Referring now to both Figures 1 and 2, the cartridge 14 may include a sheath 30 affixed to and extending from the cartridge 14, a wire 32, and a coupling 34. The wire 32 can be, for example, fixed to the coupling 34. A person of skill in the art will recognize that the wire 32 can be affixed to the coupling 34 through a variety of techniques and methods. A person of skill in the art will further recognize that the wire 32 can be affixed to a range of features of a vascular treatment device 10 configured for driving the wire 32.

[0029] The wire 32 (and surrounding sheath) can comprise a variety of lengths. In some embodiments, a wire 32 can have a length matching the needs of the procedure. In some embodiments, a wire 32 can have a length, for example, of up to 10 cm, up to 25 cm, up to 75 cm, or up to 150 cm.

[0030] The sheath 30 can be configured to define a lumen through which the wire 32 runs, and can be configured to allow independent motion of the wire within the sheath. The sheath 30 can have a variety of inner and outer diameters. In some

embodiments, the sheath 30 can have an inner diameter ranging from approximately 0.022 inches to 0.048 inches. In some embodiments, the sheath 30 can have an outer diameter ranging from approximately 0.025 inches to 0.051 inches. In some embodiments, the outer diameter of the sheath 30 can be in the range that is, for example, consistent with the inner diameter of standard needles or vascular sheaths used for used for insertion of vascular catheters.

[0031] The sheath 30 may also include external markings at regular intervals which may guide the user to monitor the insertion or removal speed of the intraluminal member 22.

[0032] Some embodiments of a vascular treatment device 10 can be configured for use with injectant. In some embodiments, the cartridge 14 can be configured for holding an injectant such as sclerosant in a syringe 36 attached to the cartridge 14 at a coupler 28. Some embodiments of a vascular treatment device 10 and/or a cartridge 14 configured for use in connection with an injectant can be, for example, configured with valves and connectors to facilitate such use. In some embodiments, a syringe 36 can, for example, connect to a stopcock 38 on a cartridge 14. The stopcock 38 shown in Figure 2 can be configured to allow the removal and/or attachment of a syringe to the vascular treatment device 10 during a procedure. In some embodiments, a stopcock 38 can be configured to allow reloading of fluid and/or exchanging of containers to, for example, change the injectant or the concentration of the injectant. In some embodiments, the stopcock 38 can be configured to provide additional functionality, such as, for example, mixing or aerating the injectant. The output of the coupler 28 is in fluid communication with the space between the sheath 30 and the wire 32 so that the injectant can be pushed along this space to the distal end of the wire and sheath where the injectant (e.g. sclerosant) exits the sheath when installed in the vein.

[0033] In use, the sheath 30 with the wire 32 inside may be introduced into the vein prior to coupling the cartridge 14 to the handle 12. At this time, the wire 32 may be fully enclosed by the sheath 30 as shown in Figure 2B. After introduction, the cartridge 14 can be inserted into the handle 12, and the coupler 34 can engage a mating coupler 40 in the handle. The coupler 34 in the cartridge which is attached to the wire 32 may be slidable within the cartridge 14, so that when the coupler 34 in the cartridge is forced into engagement with the coupler 40, the distal end of the wire 32 is pushed out of the sheath 30, as shown in Figure 2C. This exposes a portion of the wire 32 that is configured to

damage the endothelium on the inner surface of the vein. The coupler 40 in the handle 12 is attached to the shaft of a motor 42 in the handle that may rotate the coupler 40, mated coupler 34, and attached wire 32 to scrape and damage the inner wall of the vein. During this process, sclerosant may be forced down the sheath, to exit the sheath in the region near the distal end of the wire 32, as shown by arrows 46 in Figure 2C.

[0034] Motor rotation may be controlled by a trigger 48 in the handle that depresses and releases a switch 50 to start and stop motor rotation. The handle 12 may further include a power source for the motor such as battery 52.

[0035] The tips of the wire 32 can have a variety of configurations. As illustrated in Figures 2B and 2C, the distal end of the wire 32 can have a spherical ball 46 at the tip. During rotation, this ball is the feature that does the most damage to the endothelium on the inner vessel wall. Embodiments of vascular treatment devices such as illustrated in Figures 1 through 2C are further described in U.S. Patents 7,862,575 and 7,967,834 which are incorporated herein by reference in their entireties.

[0036] Although vascular ablation treatments using the above described vascular treatment device have shown dramatic improvement over prior vascular ablation methods, it has been found that the configurations of the distal ends of the wire are sometimes not optimal. For example, it is advantageous if the wire 32 removes and retains endothelium as it rotates within the vein. This retention of endothelium tissue on the wire 32 appears to increase friction and result in more complete and faster damage to the inner wall of the vein. Wire tips that are configured to retain endothelium are described further below with respect to Figures 3A through 3C.

[0037] As shown in Figure 3A, one embodiment of a wire 32 can have a series of sharp edged protrusions along an extended length of the distal end of the wire 32. This length of extension along which the protrusions are provided may extend more than 1 cm or more than 5 cm from the tip of the wire 32. At the tip of the wire 32, a larger sharp edged protrusion 66 can be provided. If desired, although not illustrated in Figure 3A, a larger sharp edged protrusion can advantageously be provided at one or more bends or corners 68 provided in the distal end of the wire 32. These sharp edges can cut and scrape the endothelium effectively, removing additional tissue. The spaces between the protrusions can retain endothelium tissue during the procedure.

[0038] In the embodiment of Figure 3B, an extended length of the distal end of the wire 32 (e.g. more than 1 cm or more than 5 cm) is provided with a roughened

surface. A roughened surface may be formed by subjecting an initially smooth steel to abrasion, machining, blasting, chemical etching such as acid etching (for example, nitric acid, hydrofluoric acid, hydrochloric acid, and/or sulfuric acid). A roughened outer surface may also be created by rolling onto an irregularly shaped guide to create surface irregularity. The wire 32 of Figure 3B also comprises relatively large cavities 70 that can retain endothelium tissue scraped off the inner vessel wall by the roughened surface.

[0039] In the embodiment of Figure 3C, an extended length of the distal end of the wire 32 (e.g. more than 1 cm or more than 5 cm) is provided with sharp edged protrusions 76, which may be formed as vanes or flanges extending from the sides of the wire 32. In this embodiment, cavities are provided as through holes 78 that can also retain endothelium tissue removed by the protrusions 76. It will be appreciated that any of the protrusions, cavities, roughened surface, etc. can be combined in a variety of manners on a single wire so that the distal end of the wire 32 is configured to both scrape away and retain endothelium tissue from the inner vessel wall during the procedure. Advantageously, catching and retaining of the endothelium can, in some embodiments, improve clinical results because scraping of tissue against tissue can cause significant abrasion to the vessel wall by increasing friction.

[0040] As shown in Figures 3B and 3C, the very tip of the wire 32 can be hemispherical. Alternatively, appointed tip can be used. A hemispherical tip can also be roughened or textured. The distal end of the wire 32 can also incorporate curved segments and straight segments. A straight segment can be distal to a curved segment.

[0041] An ablation method can further include steps to protect against over-injection of sclerosant, into the deep system. In some embodiments, an operator can observe the insertion point of the ablation device, and upon observing exiting sclerosant, an operator can stop injection of additional sclerosant. This is illustrated by the procedure of Figure 4. In this method, at block 80, the physician first advances the intraluminal member into the vein of the subject. At block 82, the physician damages the vein and injects sclerosant to ablate the vein as described above. At block 84, the physician stops injection of sclerosant in response to observing sclerosant exiting the vein through the intraluminal member access point. Injection can be stopped manually, for example, stopping pushing on the plunger of the syringe 36 of Figure 1 when sclerosant is observed exiting the access point. Advantageously, this protects against over-injection of sclerosant into the deep system, thus reducing complications of deep vein thrombosis.

[0042] In addition, methods of performing vessel ablation can include creating and maintaining specific patient positioning. A patient can be, for example, tilted to enable access to veins and then moved to a flat position for performing the vessel ablation. This is illustrated by the method shown in Figure 5. In this method, at block 90, the subject is oriented with the extremity to be treated positioned below their head. This allows easy vein access for introducing the intraluminal member into the vein at block 92. After the intraluminal member is inserted, at block 94 the subject is re-oriented with the extremity being treated level with or above their head. The procedure is then continued at block 96 where the inner vein wall is damaged and sclerosant is injected as described above. Advantageously, a flat or slightly inclined patient position allows blood and injectant to spill toward the untreated vein as the treated area of the vein gradually occludes. In one embodiment for treatment of leg veins, the patient can be tilted with legs down to facilitate vein access. The patient is then moved into a flat or only slightly head-down position. Advantageously, use of such patient positioning increases success rates for the procedure by allowing blood and sclerosant to spill toward the untreated vein which increases vein ablation and decreases the risk of deep vein thrombosis. In prior vein ablation procedures, the extremity being treated was maintained in a position below the head. The combination of vessel damage with the injection of sclerosant, however, allows the lifting of the extremity during the procedure with improved outcomes.

[0043] The foregoing description details certain embodiments of the devices and methods disclosed herein. It will be appreciated, however, that no matter how detailed the foregoing appears in text, the devices and methods can be practiced in many ways. As is also stated above, it should be noted that the use of particular terminology when describing certain features or aspects of the invention should not be taken to imply that the terminology is being re-defined herein to be restricted to including any specific characteristics of the features or aspects of the technology with which that terminology is associated.

[0044] It will be appreciated by those skilled in the art that various modifications and changes may be made without departing from the scope of the described technology. Such modifications and changes are intended to fall within the scope of the embodiments. It will also be appreciated by those of skill in the art that parts included in one embodiment are interchangeable with other embodiments; one or more parts from a depicted embodiment can be included with other depicted embodiments in

any combination. For example, any of the various components described herein and/or depicted in the Figures may be combined, interchanged or excluded from other embodiments.

[0045] With respect to the use of substantially any plural and/or singular terms herein, those having skill in the art can translate from the plural to the singular and/or from the singular to the plural as is appropriate to the context and/or application. The various singular/plural permutations may be expressly set forth herein for sake of clarity.

[0046] It will be understood by those within the art that, in general, terms used herein are generally intended as “open” terms (e.g., the term “including” should be interpreted as “including but not limited to,” the term “having” should be interpreted as “having at least,” the term “includes” should be interpreted as “includes but is not limited to,” etc.). It will be further understood by those within the art that if a specific number of an introduced claim recitation is intended, such an intent will be explicitly recited in the claim, and in the absence of such recitation no such intent is present. For example, as an aid to understanding, the following appended claims may contain usage of the introductory phrases “at least one” and “one or more” to introduce claim recitations. However, the use of such phrases should not be construed to imply that the introduction of a claim recitation by the indefinite articles “a” or “an” limits any particular claim containing such introduced claim recitation to embodiments containing only one such recitation, even when the same claim includes the introductory phrases “one or more” or “at least one” and indefinite articles such as “a” or “an” (e.g., “a” and/or “an” should typically be interpreted to mean “at least one” or “one or more”); the same holds true for the use of definite articles used to introduce claim recitations. In addition, even if a specific number of an introduced claim recitation is explicitly recited, those skilled in the art will recognize that such recitation should typically be interpreted to mean at least the recited number (e.g., the bare recitation of “two recitations,” without other modifiers, typically means at least two recitations, or two or more recitations). It will be further understood by those within the art that virtually any disjunctive word and/or phrase presenting two or more alternative terms, whether in the description, claims, or drawings, should be understood to contemplate the possibilities of including one of the terms, either of the terms, or both terms. For example, the phrase “A or B” will be understood to include the possibilities of “A” or “B” or “A and B.”

[0047] All references cited herein are incorporated herein by reference in their entirety. To the extent publications and patents or patent applications incorporated by reference contradict the disclosure contained in the specification, the specification is intended to supersede and/or take precedence over any such contradictory material.

[0048] The term “comprising” as used herein is synonymous with “including,” “containing,” or “characterized by,” and is inclusive or open-ended and does not exclude additional, unrecited elements or method steps.

WHAT IS CLAIMED IS:

1. A vascular treatment apparatus comprising:
an elongated intraluminal member shaped and dimensioned for passage through blood vessels of a subject, the intraluminal member including a proximal end and a distal end, wherein the distal end comprises a vein wall disruptor;
wherein the vein wall disruptor is configured to scrape tissue off of the inner wall of a blood vessel, and retain that tissue on the disruptor during use.
2. The apparatus of Claim 1, wherein the distal end of the intraluminal member terminates with a hemispheric free end.
3. The apparatus according to Claim 1, wherein the distal end of the intraluminal member terminates with a pointed free end.
4. The apparatus according to Claims 1, wherein the distal end of the intraluminal member terminates with a textured hemispheric free end.
5. The apparatus according to Claim 1, wherein the distal end of the intraluminal member has a roughened surface.
6. The apparatus according to Claim 1, wherein the distal end of the intraluminal member comprises a curved segment.
7. The apparatus according to Claim 1, wherein the distal end of the intraluminal member comprises straight segment distal to the curved segment.
8. The apparatus according to Claim 1, additionally comprising:
a source of sclerosant; and
a fluid channel between the source of sclerosant and the distal end of the elongated intraluminal member.
9. A vascular treatment apparatus comprising:
an elongated intraluminal member shaped and dimensioned for passage through blood vessels of a subject, the intraluminal member including a proximal end and a distal end, wherein the distal end comprises a vein wall disruptor;
wherein the vein wall disruptor is configured to scrape tissue off of the inner wall of a blood vessel, and wherein the vein wall disruptor comprises structures therein forming tissue storing regions.
10. The apparatus of Claim 9, wherein the structures comprise cavities.
11. The apparatus of Claim 10, wherein the structures comprise through holes.

12. The apparatus according to Claim 1, additionally comprising:
 - a source of sclerosant; and
 - a fluid channel between the source of sclerosant and the distal end of the elongated intraluminal member.
13. A vascular treatment method comprising the following steps:
 - advancing an elongated intraluminal member from an access site and into the vein, wherein the intraluminal member has a portion thereof configured to produce damage to the inner vessel wall;
 - damaging the inner vessel wall by performing a defined movement of the portion of the intraluminal member against the vein's endothelium, wherein the damaging comprises removing endothelium tissue from the inner vessel wall and retaining endothelium tissue on the portion of the intraluminal member while performing the defined movement.
14. The method of Claim 13, comprising injecting sclerosant into the vein and onto the damaged inner vessel wall.
15. The method of Claim 13, comprising retaining endothelium tissue in cavities on the portion of the intraluminal member.
16. The method of Claim 13, comprising retaining endothelium tissue in through holes on the portion of the intraluminal member.
17. A method for permanently occluding a vein through the combined disruption of a vein vessel wall and application of a sclerosant, comprising the following steps:
 - advancing an elongated intraluminal member from an access site and into the vein, wherein the intraluminal member has a portion thereof configured to produce damage to the inner vessel wall of the vein under user control when performing a defined movement;
 - damaging the inner vessel wall by performing the defined movement of the portion of the intraluminal member against the vein's endothelium;
 - injecting sclerosant into the vein and onto the damaged inner vessel wall
 - observing sclerosant exiting from the access site; and
 - stopping injection of sclerosant in response to the observing.
18. The method according to Claim 17, wherein an injector is stopped to stop the injection of sclerosant.

19. The method according to Claim 18, wherein the injector comprises a plunger in a syringe.

20. A method for permanently occluding a vein through the combined disruption of a vein vessel wall and application of a sclerosant, comprising the following steps:

orienting a subject with at least one extremity below their head;

advancing an elongated intraluminal member from an access site and into a vein in the at least one extremity, wherein the intraluminal member has a portion thereof configured to produce damage to the inner vessel wall of the vein under user control when performing a defined movement;

re-orienting the subject with the at least one extremity approximately level with or slightly above their head;

damaging the inner vessel wall by performing the defined movement of the portion of the intraluminal member against the vein's endothelium; and

injecting sclerosant into the vein and onto the damaged inner vessel wall.

21. A method according to Claim 20, wherein the at least one extremity comprises at least one arm.

22. A method according to Claim 20 wherein the at least one extremity comprises at least one leg.

23. A method according to claim 41 wherein the orienting and re-orienting the subject comprises tilting the subject.

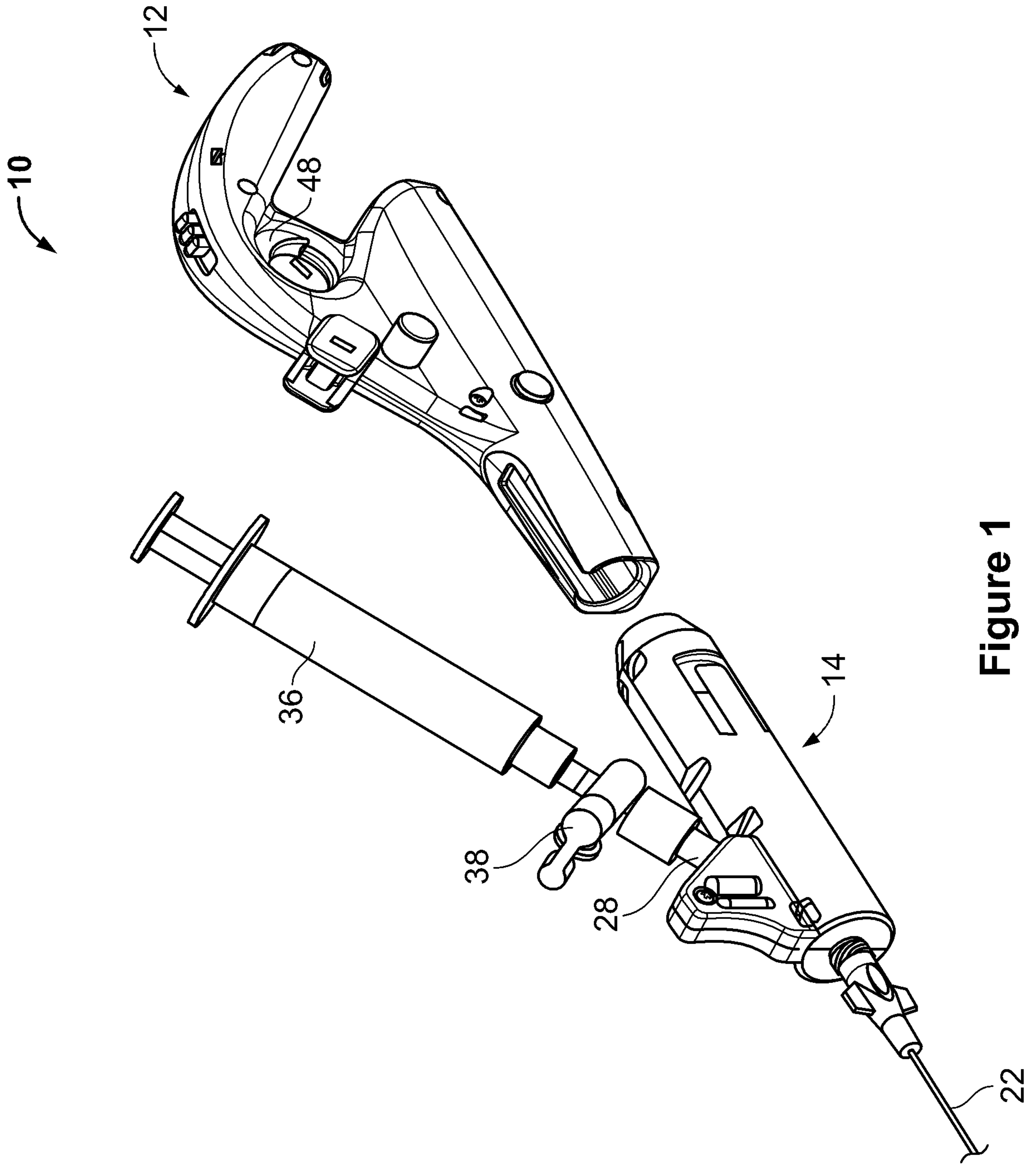

Figure 1

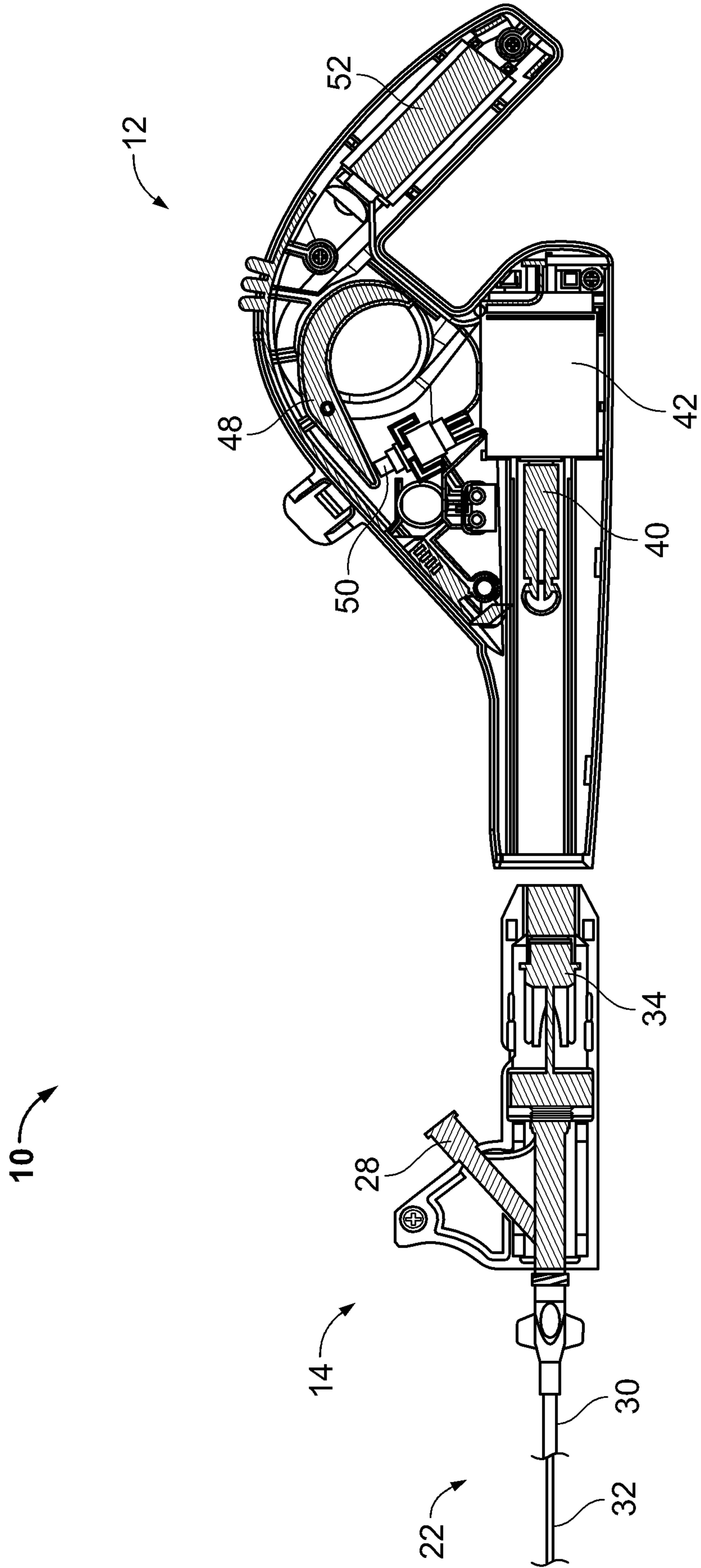

Figure 2A

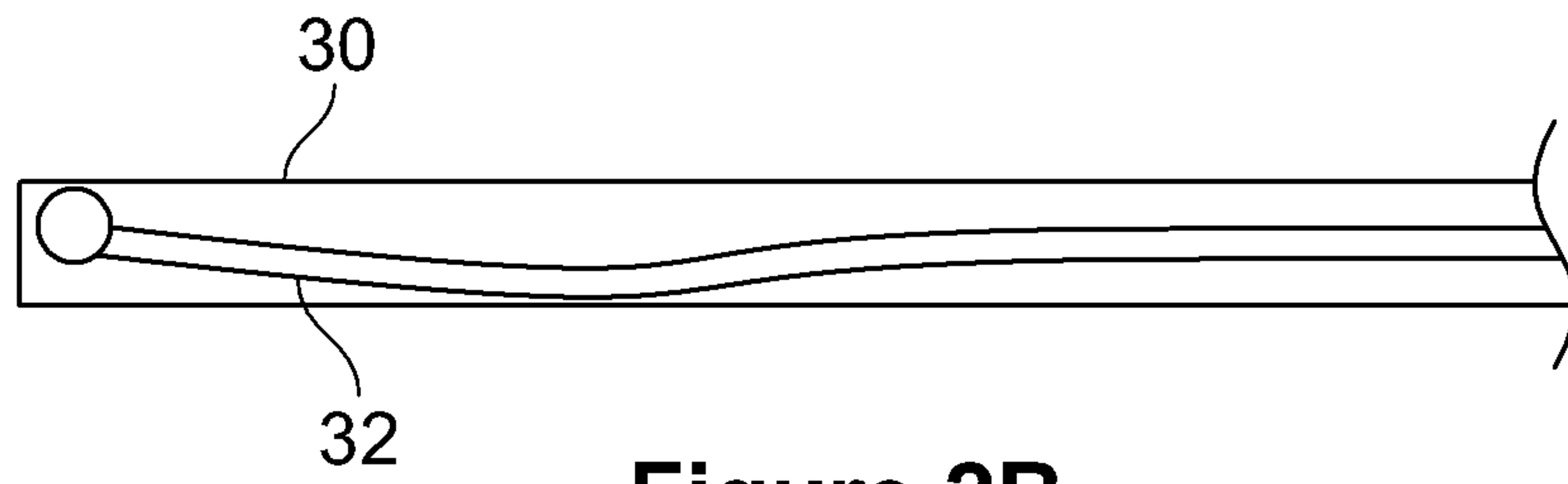

Figure 2B

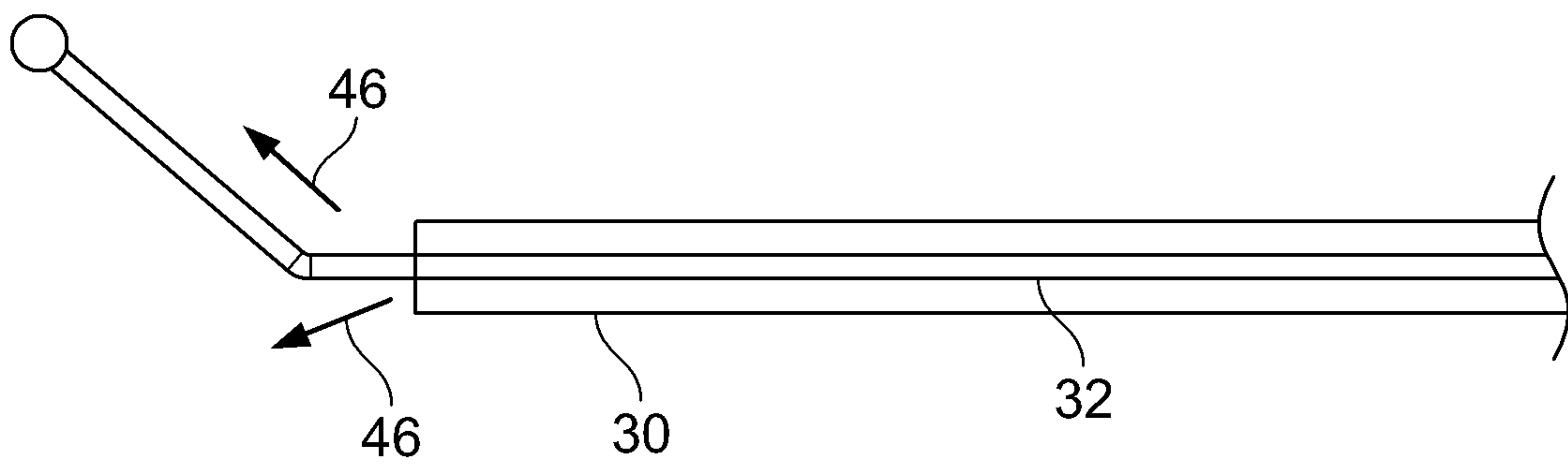

Figure 2C

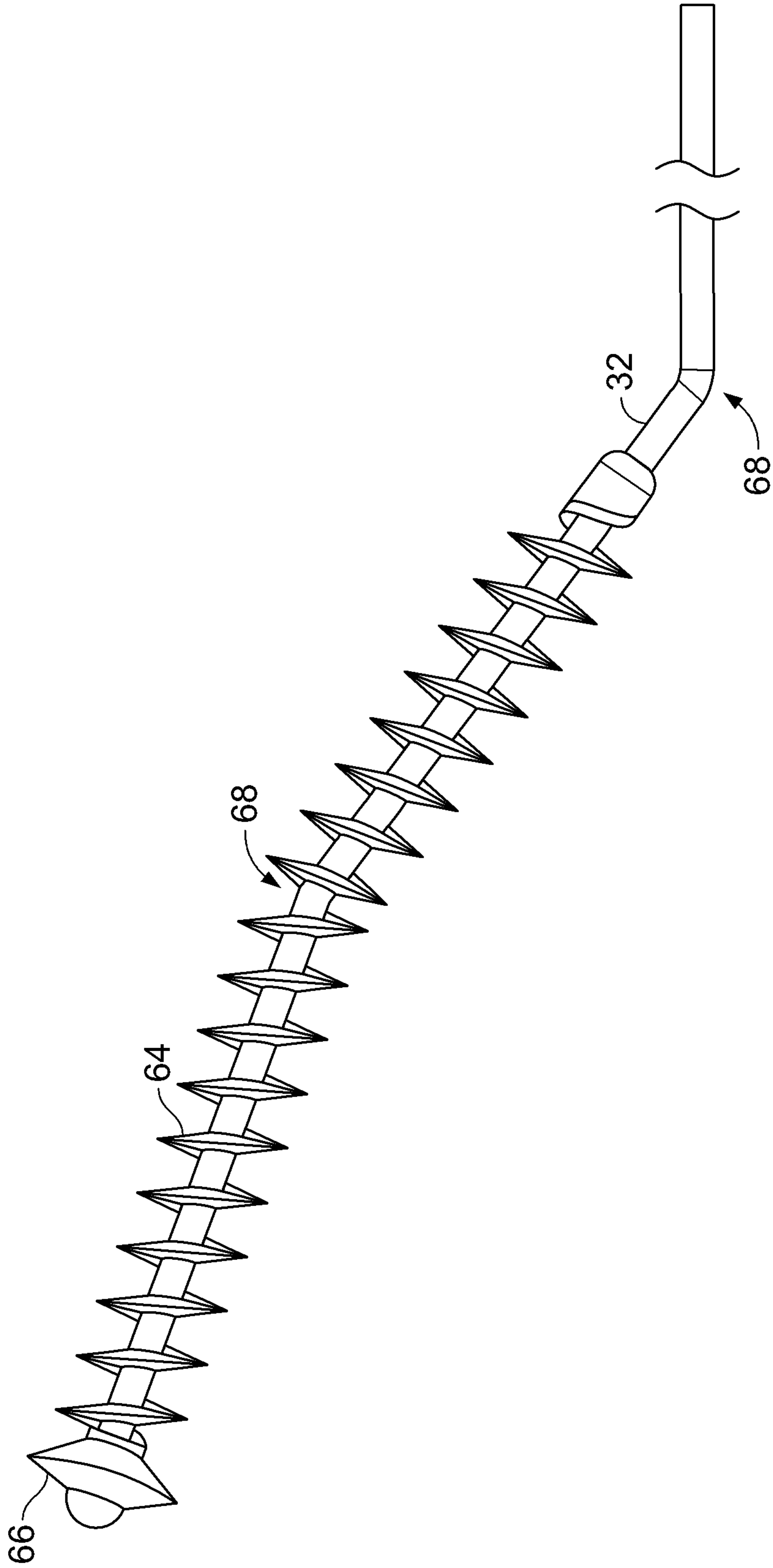

Figure 3A

Figure 3B

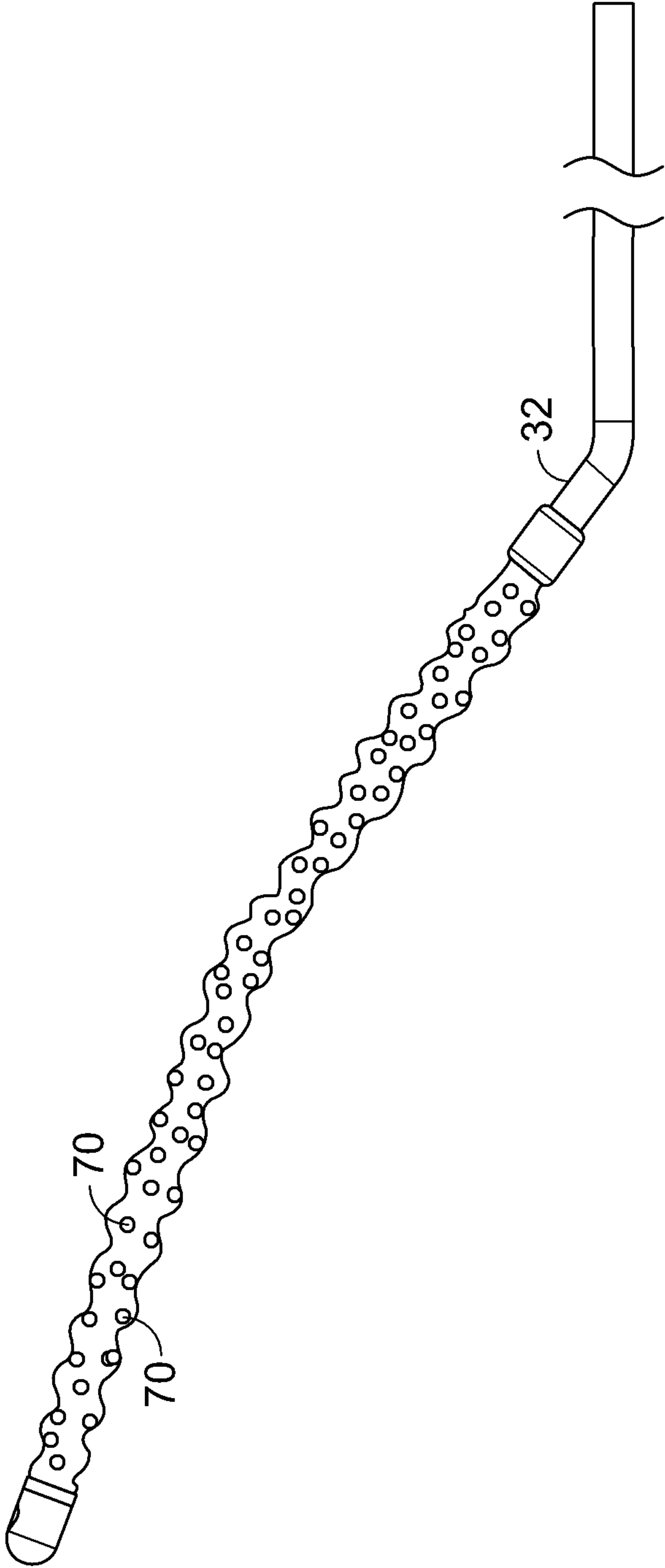
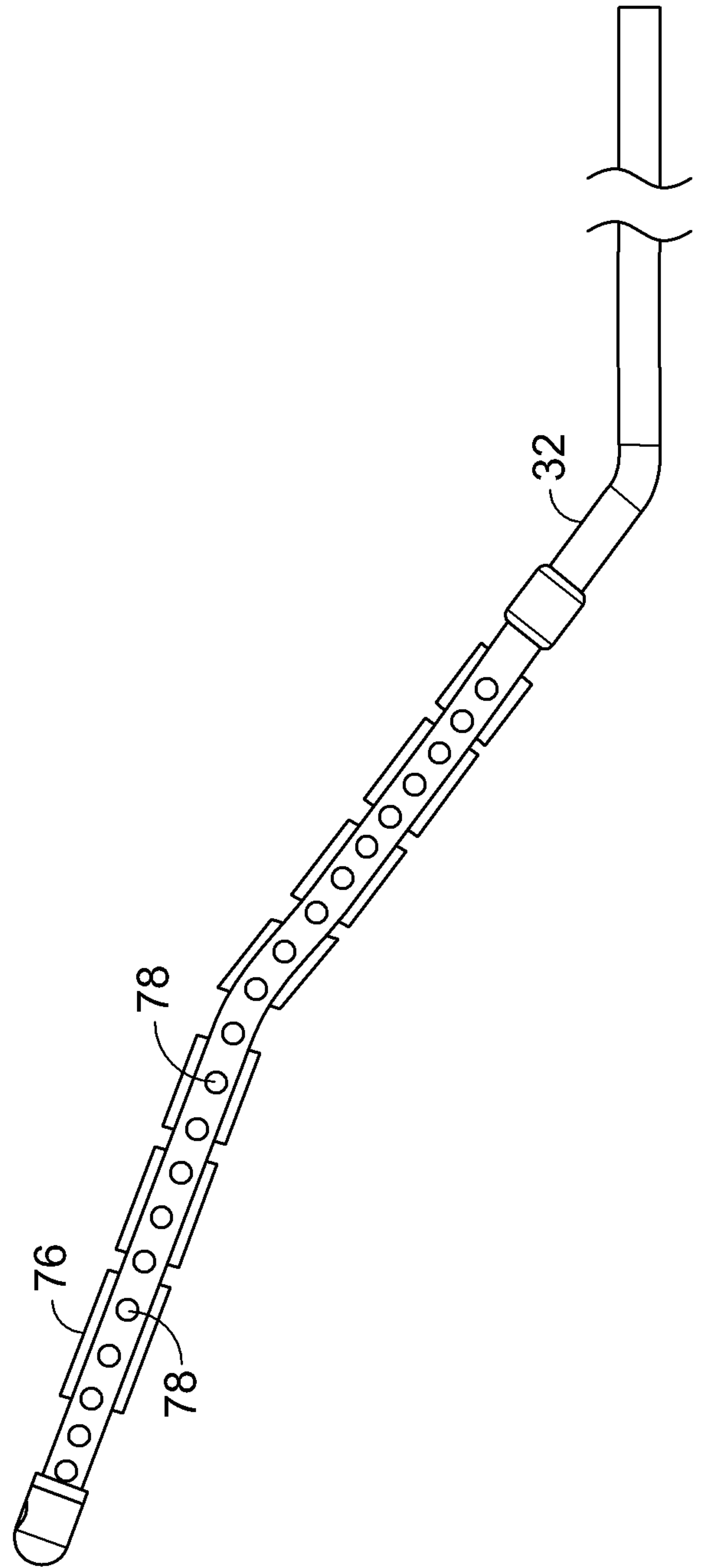
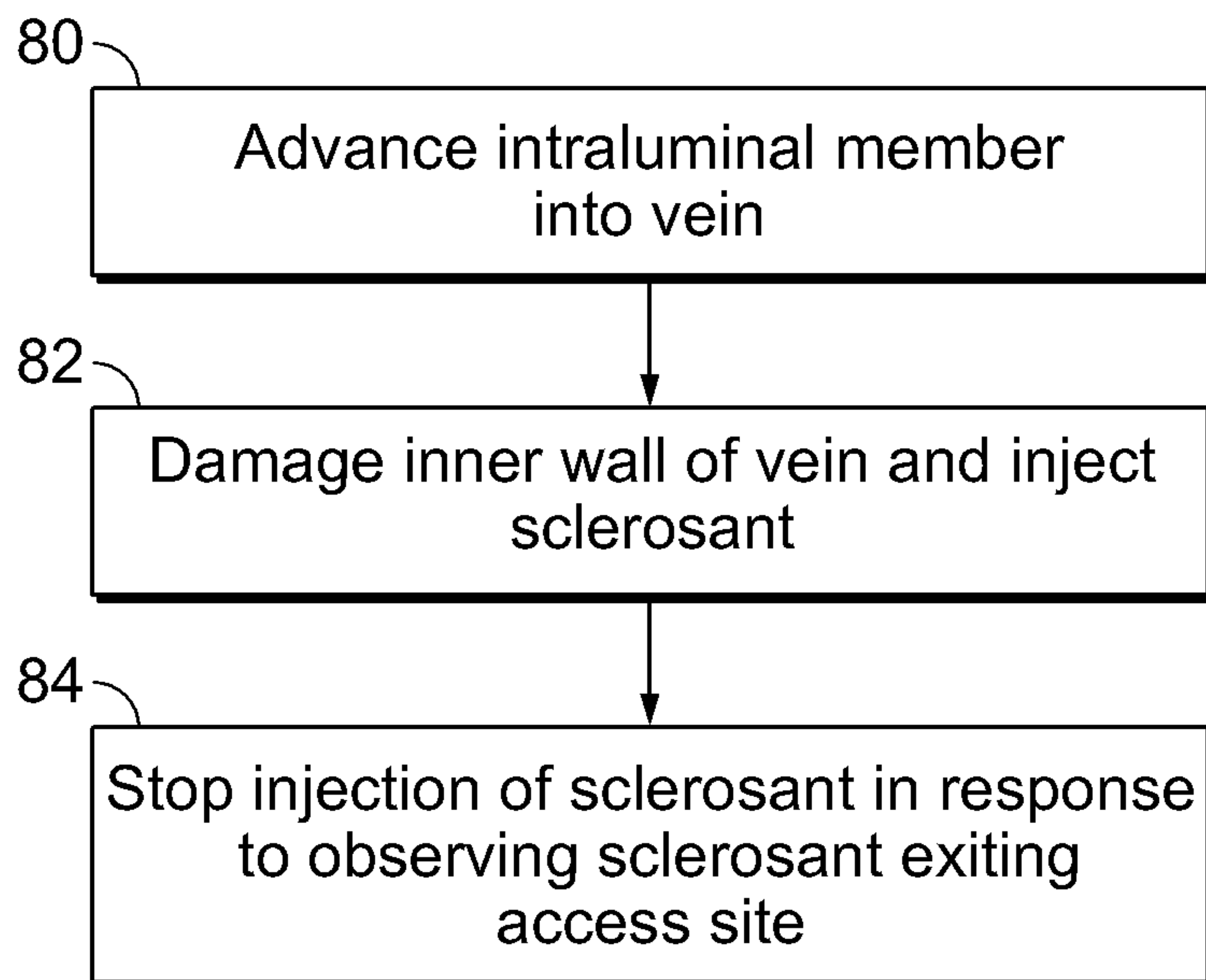
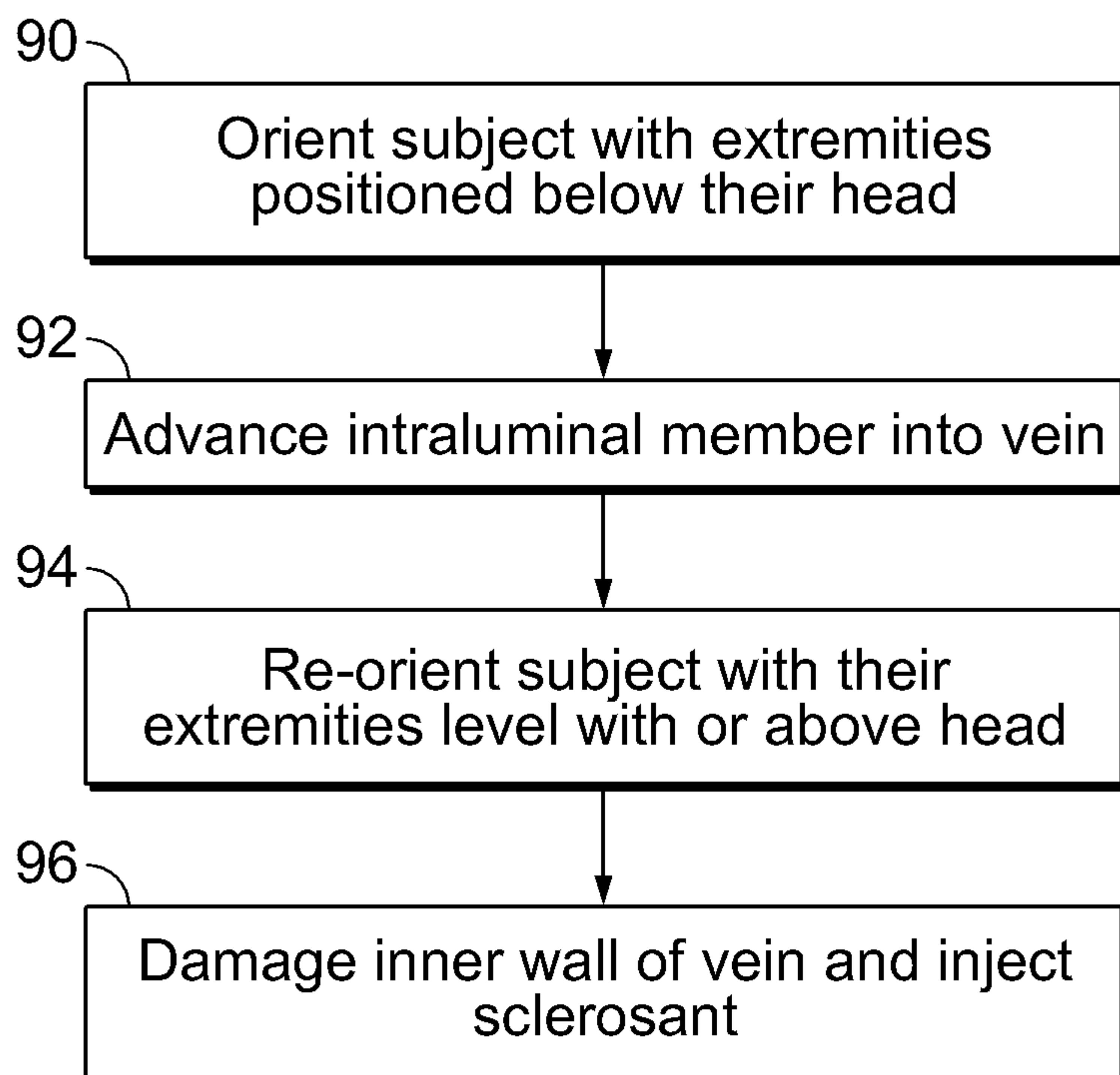

Figure 3C



6/6

**Figure 4****Figure 5**

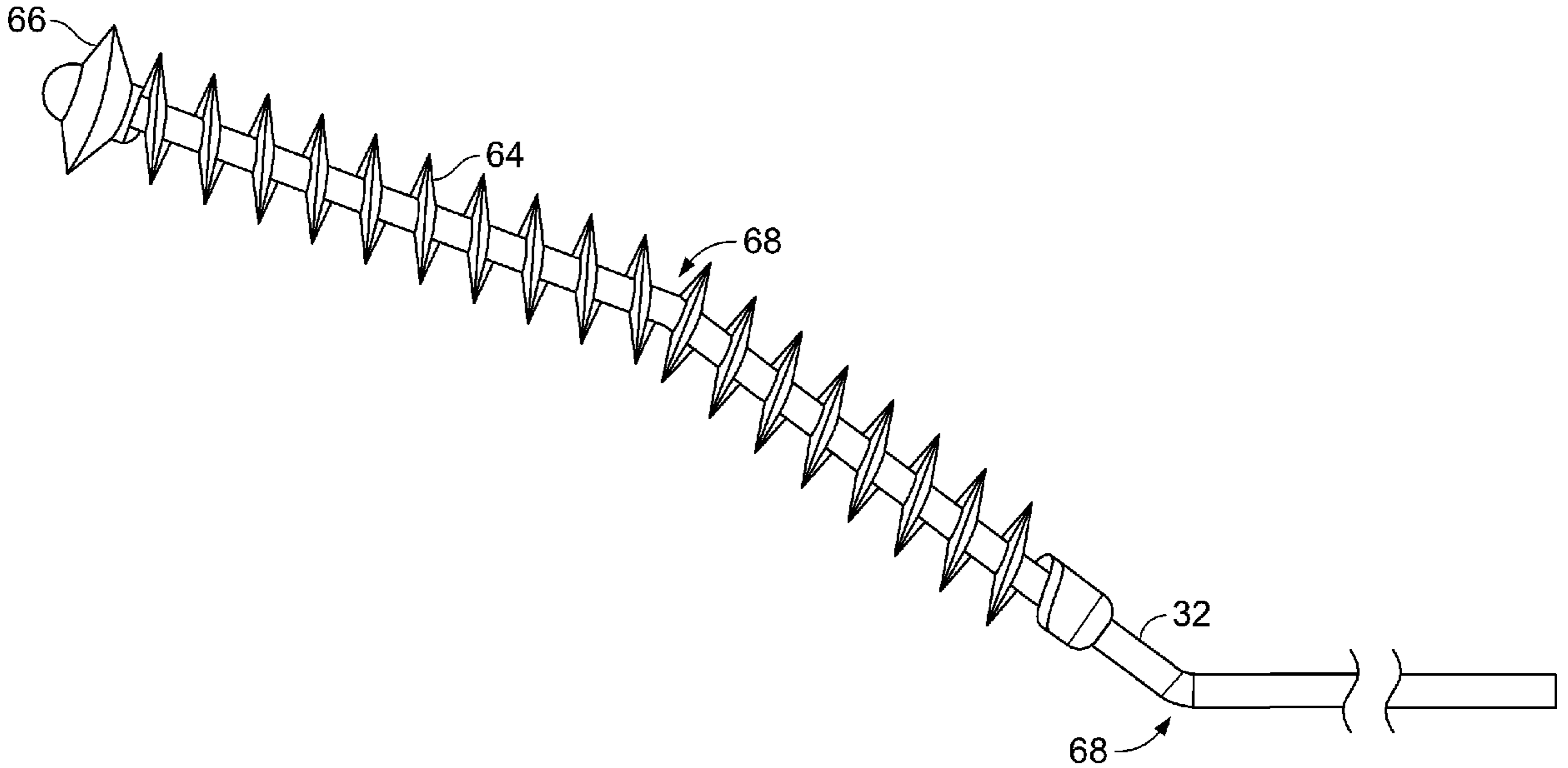

Figure 3A