

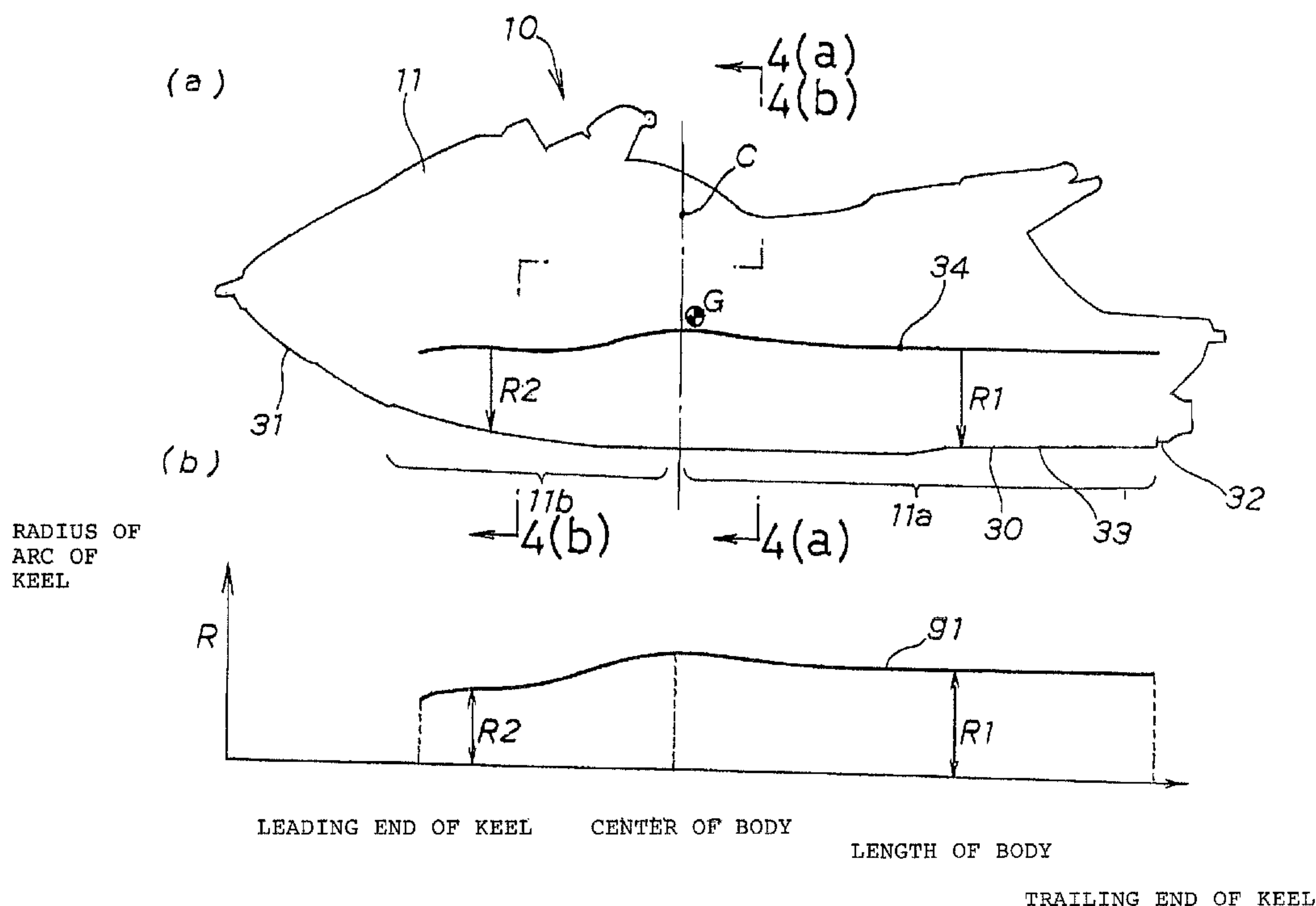

(22) Date de dépôt/Filing Date: 2002/11/15
(41) Mise à la disp. pub./Open to Public Insp.: 2003/07/14
(45) Date de délivrance/Issue Date: 2006/10/03
(30) Priorité/Priority: 2002/01/14 (US60/347,293)

(51) Cl.Int./Int.Cl. *B63B 9/00* (2006.01),
B63B 3/38 (2006.01), *B63B 35/73* (2006.01),
B63B 38/00 (2006.01)
(72) Inventeurs/Inventors:
KOCHI, TAKAO, JP;
ABE, TOMOHISA, JP
(73) Propriétaire/Owner:
HONDA GIKEN KOGYO KABUSHIKI KAISHA, JP
(74) Agent: DENNISON ASSOCIATES

(54) Titre : MOTOMARINE
(54) Title: PERSONAL WATERCRAFT



(57) **Abrégé/Abstract:**

To provide a personal watercraft which suitably assures a straightforwardly advancing property and prevents an influence of a side wave and wherein the body can be inclined to the turning center side in accordance with a steering condition upon turning. The personal watercraft 10 includes a keel 33 provided at a middle portion in the widthwise direction of the bottom 30 of the body 11 and extending from the bow 31 to the stern 32, and the keel 33 is formed in an arc in the widthwise direction of the body. The keel 33 is configured such that, at the rear half portion 11a of the body 11, the center 34 of the arc of the keel 33 substantially coincides with the position G of the center of gravity of the body 11, and at the front half portion 11b of the body 11, the radius R2 of the arc of the keel 33 gradually decreases forwardly.

ABSTRACT OF THE DISCLOSURE

To provide a personal watercraft which suitably assures a straightforwardly advancing property and prevents an influence of a side wave and wherein the body can be inclined to the turning center side in accordance with a steering condition upon turning. The personal watercraft 10 includes a keel 33 provided at a middle portion in the widthwise direction of the bottom 30 of the body 11 and extending from the bow 31 to the stern 32, and the keel 33 is formed in an arc in the widthwise direction of the body. The keel 33 is configured such that, at the rear half portion 11a of the body 11, the center 34 of the arc of the keel 33 substantially coincides with the position G of the center of gravity of the body 11, and at the front half portion 11b of the body 11, the radius R2 of the arc of the keel 33 gradually decreases forwardly.

PERSONAL WATERCRAFT

FIELD OF THE INVENTION

5 This invention relates to a personal watercraft which includes a saddle type seat extending in a forward and backward direction at a middle portion of a body, an operation handle member provided forwardly of the seat, and an arcuate keel provided at a middle portion of a bottom of the body.

10

BACKGROUND OF THE INVENTION

As a personal watercraft, a jet propulsion watercraft is known wherein a water jet propeller is mounted at a rear portion of a body and is driven by an engine to be taken in water from the bottom and jet the thus taken-in water rearwardly to propel the body.

This personal watercraft includes a keel provided at a middle portion of the bottom and extending forwardly and rearwardly (that is, from the bow to the stern).

FIG. 8 shows a sectional view of a conventional personal watercraft. The personal watercraft 100 is configured such that a keel 101 is formed in such a manner as to project downwardly so that it may project by a comparatively great amount downwardly from a middle portion of a bottom 102.

As the keel 101 projects downwardly by a comparatively great amount, the straightforwardly advancing property of the personal watercraft 100 when it is propelled can be maintained suitably.

5 However, where the keel 101 projects downwardly by a comparatively great amount, for example, if the personal watercraft 100 is acted upon by a side wave while it glides, then the keel 101 is liable to be influenced by the side wave. As the keel 101 is influenced by a side wave in this manner, the personal watercraft 100 is rolled leftwardly or rightwardly.

10

As a personal watercraft which is not influenced by a side wave, for example, a "Personal Jet Propulsion Watercraft" of the official gazette of Japanese Patent Publication No. Hei 6-96397 is known. In the following, the personal watercraft is described in detail with reference to the
15 succeeding figures (FIGS. 9 and 10) derived from FIGS. 1 and 4(A), respectively, shown in the official gazette (however, reference numerals are re-numbered).

FIG. 9 is a sectional view showing another example of a conventional
20 personal watercraft. The personal watercraft 110 is configured such that a keel 111 is formed flat so that it may not project downwardly from a bottom 112.

According to this personal watercraft 110, even when it is acted upon by a
25 side wave while it glides, the keel 111 is influenced comparatively little by a side wave. Therefore, the personal watercraft 110 is not rolled leftwardly or rightwardly.

FIG. 10 is a plan view showing the other example of a conventional
30 personal watercraft. As a crew-member 115 of the personal watercraft 110 operates an operation handle member 116 as indicated by an arrow mark b, a steering nozzle (not shown) of a body rear portion 117 is swingably

moved.

Consequently, a water jet 118 jetted from the steering nozzle is directed obliquely as indicated by an arrow mark c so that the personal watercraft 110 can be turned as indicated by an open arrow mark.

However, if the keel 111 is formed flat so that it may not be influenced by a side wave, then when the personal watercraft 110 is to be turned, the body is pushed by water from a sideward direction and tends to be inclined inwardly. However, where the bottom is formed flat, when the body begins to be inclined, the flat face of the body acts as resistance and is less liable to be inclined.

Therefore, it is demanded to make the personal watercraft 110 which can be inclined readily when the body begins to be inclined upon turning of the personal watercraft 110 so that the personal watercraft 110 can be placed into a turning condition from a straightforwardly advancing condition in a natural feeling, for example, as with a motorcycle into practical use.

Therefore, the object of the present invention resides in provision of a personal watercraft which suitably assures a straightforwardly advancing property and prevents an influence of a side wave and besides can be inclined readily when the body begins to be inclined upon turning of the personal watercraft.

25

SUMMARY OF THE INVENTION

In order to attain the object described above, according to the present invention, a personal watercraft which includes a saddle type seat extending in a forward and backward direction at a middle portion of a deck of a body, an operation handle member provided forwardly of the seat, a pair of foot decks formed on the opposite sides of the seat, and a keel provided at a middle portion of a bottom of the body and extending from a

30

bow to a stern and wherein the keel is formed in an arc, is characterized in that the center of the arc of the keel extending in the forward and backward direction of the body substantially coincides with the height of the position of the center of gravity of the body at a location rearwardly of
5 the center of the body.

At the portion of the body rearwardly of the center of the body, the center of the arc of the keel substantially coincides with the height of the position of the center of gravity of the body. Consequently, the radius of the arc of
10 the keel can be made large. As the radius of the arc of the keel becomes large, the keel can be prevented from projecting downwardly by a great amount from the bottom. Where the projecting amount of the keel is suppressed in this manner, the keel is less likely to be influenced by a side wave so that the body can be prevented from being rolled leftwardly or
15 rightwardly by an influence of a side wave.

Further, since the center of the arc of the keel substantially coincides with the height of the position of the center of gravity of the body, when a crew-member performs a steering operation and the body turns its direction
20 from a forwardly advancing direction to a turning direction and is pushed by water from a sideward direction, whereupon the body begins to be inclined toward the center of the turning movement, the body can be inclined around the height of the position of the center of gravity. Therefore, the body is inclined readily.

25

Consequently, since the body can be inclined smoothly toward the center of the turning movement by a natural movement, the posture of the personal watercraft can be changed from an uprightly standing posture upon straightforward advancement to an inclined posture upon turning
30 with the same sense as the sense of operation of a motorcycle.

According to an aspect of the invention, the personal watercraft is

characterized in that the radius of the arc of the keel gradually decreases forwardly at a location forwardly of the center of the body.

5 Since, at the portion of the body forwardly of the center of the body, the radius of the arc of the keel gradually decreases forwardly, the keel at the portion of the body forwardly of the center of the body can be made project by a comparatively great amount from the bottom.

10 Consequently, since the plowing property by the keel when the personal watercraft advances straightforwardly can be improved, when the personal watercraft is hit by a high wave during gliding thereof, the impact provided to the body can be suppressed low and improvement in the driving comfortability can be anticipated.

15 **BRIEF DESCRIPTION OF THE DRAWINGS**

Preferred embodiments of the invention are shown in the drawings, wherein:

20 FIG. 1 is a side elevational view of a personal watercraft according to the present invention.

FIG. 2 is an enlarged view of essential part showing essential part of the personal watercraft according to the present invention.

25 FIGS. 3(a) and 3(b) are views illustrating the shape of a keel which is a component of the personal watercraft according to the present invention.

FIGS. 4(a) and 4(b) are sectional views of FIG. 3(a) according to the present invention.

30

FIGS. 5(a) and 5(b) are views illustrating action of the personal watercraft according to the present invention when it glides straightforwardly.

FIGS. 6(a) and 6(b) are views illustrating first action of the personal watercraft according to the present invention when it is turned.

5 FIGS. 7(a) and 7(b) are views illustrating second action of the personal watercraft according to the present invention when it is turned.

FIG. 8 is a sectional view of a conventional personal watercraft.

10 FIG. 9 is a sectional view showing another example of a conventional personal watercraft.

FIG. 10 is a plan view showing the other example of a conventional personal watercraft.

15

DETAILED DESCRIPTION OF THE PREFERRED EMBODIMENTS

An embodiment of the present invention is described below with reference to the accompanying drawings. Here, the terms "front", "rear", "left" and "right" are defined as directions as viewed from the driver.

20 Further, the drawings should be viewed in the direction of the reference characters.

FIG. 1 is a side elevational view of a personal watercraft according to the present invention.

25

The personal watercraft 10 is a water jet propulsion watercraft configured such that a saddle type seat 14 extending in a forward and rearward direction is provided at a deck middle portion 12a of a body 11; an operation handle member 15 is provided forwardly of the seat 14; a pair of
30 left and right foot decks 13 (refer to FIGS. 4(a) and 4(b)) are formed on the opposite sides of the seat 14; a fuel tank 17 is mounted in the inside of the body 11; an engine 18 is provided rearwardly of the fuel tank 17; a jet

propeller chamber 19 is provided rearwardly of the engine 18; a water jet propeller 20 is provided in the jet propeller chamber 19; and a steering nozzle 21 is provided rearwardly of the water jet propeller 20, and the direction of the steering nozzle 21 is controlled by the operation handle member 15.

According to this personal watercraft 10, a crew-member rides on the seat 14 with the left and right feet thereof placed on the left and right foot decks 13, respectively, and grips the operation handle member 15 with the left and right hands thereof to steer the personal watercraft.

When the engine 18 of the personal watercraft 10 is driven while the crew-member grips the operation handle member 15, rotation of the engine 18 can be transmitted to an impeller 23 through a drive shaft 22 to rotate the impeller 23.

As the impeller 23 is rotated, water is taken in through an intake opening 24 of the bottom 30, and the thus taken-in water is jetted rearwardly as a water jet from the steering nozzle 21. As the water jet is jetted rearwardly from the steering nozzle 21, the personal watercraft 10 can be propelled.

FIG. 2 is an enlarged view of essential part showing essential part of the personal watercraft according to the present invention.

The personal watercraft 10 includes a keel 33 provided at a middle portion in the widthwise direction of the bottom (that is, the watercraft bottom) 30 of the body 11 and extending from the bow 31 to the stern 32. The keel 33 is formed in an arc in the widthwise direction of the body. The personal watercraft 10 has also a pair of left and right inclined faces 35 and 37 extending outwardly in the widthwise direction from respective left and right sides 33a and 33b of the keel 33, and a pair of left and right wall faces 41 and 43 (the right wall face 43 is shown in FIGS. 4(a) and 4(b)) extending

substantially vertically from outer side 35a of the left inclined face 35 and outer side 37a of the right inclined face 37, respectively.

5 The keel 33 has the intake opening 24 adjacent the stern 32. A plurality of grating members 25 are provided in the intake opening 24, and a ride plate 26 is provided rearwardly of the grating members 25.

10 The under portion of the jet propeller chamber 19 is closed up by covering an opening 30a of the bottom 30 with the ride plate 26. The water jet propeller 20 (shown in FIG. 1) is provided in the jet propeller chamber 19, and the steering nozzle 21 is mounted for swinging motion on a jet nozzle 20a (at an end portion) of the jet nozzle 20a.

15 The left and right inclined faces 35 and 37 respectively provided on the left and right sides 33a and 33b of the keel 33 form left and right inner side chines (edges) 45 on the inner sides (that is, on the left and right sides of the keel) 33a and 33b of the inclined faces 35 and 37, form left and right central chines 46 at middle portions of the left and right inclined faces 35 and 37, and form left and right outer side chines 47 on the outer sides 35a and 37a of the inclined faces 35 and 37, respectively.

25 On the outer sides 35a and 37a of the left and right inclined faces 35 and 37, the left and right wall faces 41 and 43 are formed substantially vertically, respectively, and left and right sponsons 42 and 44 are provided at rear portions of the left and right wall faces 41 and 43, respectively.

30 The left and right sponsons 42 and 44 act as resistance when the body 11 is inclined to a predetermined angle upon turning of the body 11 thereby to prevent the body 11 from being inclined any more and prevent the body 11 from sliding to the outer side by centrifugal force upon turning.

FIGS. 3(a) and 3(b) are views showing the shape of the keel which is a

component of the personal watercraft according to the present invention, and FIG. 3(a) is a view illustrating the center of the arc of the keel 33. Meanwhile, FIG. 3(b) is a view illustrating a radius R of the arc of the keel 33, where the axis of ordinate indicates the radius R of the arc of the keel, the axis of abscissa indicates the length of the body, and the radius R of the arc of the keel is indicated by a graph g1. It is to be noted that the position G of the center of gravity of the personal watercraft 10 represents the position of the center of gravity including the crew-member.

10 The keel 33 is a member which extends like a belt from the bow 31 to the stern 32 and is formed in an arc in the widthwise direction (refer also to FIG. 2).

This keel 33 is configured such that, at a portion (that is, a rear half portion of the body) 11a of the body 11 rearwardly of the center C in the forward and backward direction, the center 34 of the arc of the keel 33 substantially coincides with the height of the position G of the center of gravity of the body 11, and at a portion (that is, a front half portion of the body) 11b of the body 11 forwardly of the center C, the radius R of the arc of the keel 33 (in the following description, the radius of the arc of the keel on the front half portion 11b side is represented as "R2") gradually decreases forwardly.

At the rear half portion 11a of the body 11, the center 34 of the radius R of the arc (in the following description, the radius of the arc of the keel at the rear half portion 11a is represented as "R1") of the keel 33 substantially coincides with the height of the position G of the center of gravity of the body 11. Consequently, since the center of the radius R1 of the arc of the keel 33 can be set to a comparatively high position, the radius R1 of the arc can be made large.

30

As the radius R1 of the arc of the keel 33 of the body 11 becomes large, the keel 33 can be prevented from projecting downwardly by a great amount

from the bottom 30. Where the projecting amount of the keel 33 is suppressed, the keel 33 can be prevented from being influenced by a side wave so that the body 11 can be prevented from being rolled leftwardly or rightwardly by an influence of a side wave.

5

Further, the keel 33 is configured such that it does not project downwardly by a great amount from the bottom 30 and the center 34 of the arc of the keel 33 substantially coincides with the height of the position G of the center of gravity of the personal watercraft 10. Consequently, when a crew-member 50 (refer to FIGS. 5(a) and 5(b)) performs a steering operation of the operation handle member 15 and the body 11 turns its direction from a forwardly advancing direction to a turning direction and is pushed by water from a sideward direction, whereupon the body 11 begins to be inclined toward the center of the turning movement, the body 11 can be inclined around the height of the position of the center of gravity. Therefore, the body 11 is inclined readily.

Consequently, since the personal watercraft 10 can be inclined smoothly to the center of the turning movement by a natural movement, the posture of the personal watercraft 10 can be changed from an uprightly standing posture upon straightforward advancement to an inclined posture upon turning with the same sense as the sense of operation of a motorcycle.

At the portion (that is, a front half portion of the body) 11b of the body 11 forwardly of the center C, the radius R2 of the arc of the keel 33 is set so as to gradually decrease forwardly. Consequently, since the keel 33 at the front half portion 11b can be made project by a comparatively great amount from the bottom 30, the plowing property by the keel 33 when the personal watercraft 10 advances straightforwardly can be improved.

30

FIGS. 4(a) and 4(b) are sectional views of FIG. 3(a) according to the present invention, and FIG. 4(a) is a sectional view taken along line a-a and FIG.

4(b) is a sectional view taken along line b-b.

FIG. 4(a) shows the rear half portion 11a of the body 11. This body 11 is configured such that a lower half portion thereof is formed from a hull 28
5 and an upper half portion thereof is formed from a deck 12.

The hull 28 is configured such that a middle portion of the bottom 30 is formed from the keel 33; a float member (foamed material) 49 is provided on the rear face of the keel 33; the left and right inclined faces 35 and 37 are
10 extended in an ascending gradient continuously from the left and right sides 33a and 33b of the keel 33 to the outer sides of the body 11, respectively; the float members (foamed material) 49 are also provided on the rear faces of the inclined faces 35 and 37; the left and right wall faces 41 and 43 are extended substantially vertically from the outer sides 35a and
15 37a of the left and right inclined faces 35 and 37, respectively; and float members (foamed material) 49 are also provided individually on the rear faces of the wall faces 41 and 43.

At the rear half portion 11a from a middle portion of the body, the center
20 34 of the radius R1 of the arc of the keel 33 substantially coincides with the height of the position G of the center of gravity of the body 11. Consequently, since the center 34 of the radius R1 of the arc of the keel 33 can be positioned at a comparatively high position, the radius R1 of the arc can be set large.

25

Since the radius R1 of the arc of the keel 33 is large, the projecting amount by which the keel 33 projects downwardly from the body 11 can be suppressed small when compared with a keel 55 (indicated by imaginary lines) having a smaller arc radius.

30

Further, the center 34 of the arc of the keel 33 substantially coincides with the height of the position G of the center of gravity of the body 11.

Consequently, when a crew-member 50 (refer to FIGS. 5(a) and 5(b)) performs a steering operation of the operation handle member 15 and the body 11 turns its direction from a forwardly advancing direction to a turning direction and is pushed by water from a sideward direction, whereupon the body 11 begins to be inclined toward the center of the turning movement, the body 11 is inclined around the height of the position of the center of gravity. Therefore, the body 11 can be inclined readily toward the center of the turning movement.

FIG. 4(b) shows the radius R2 of the arc of the keel 33 which is set, at the front half portion 11b of the body 11, so as to gradually decrease forwardly from the center C (shown in FIGS. 3(a) and 3(b)) of the body 11. Since the radius R2 of the arc of the keel 33 is set so as to gradually decrease forwardly, the keel 33 at the front half portion 11b can be made project by a comparatively great amount from the bottom 30. Consequently, the plowing property by the keel 33 when the personal watercraft 10 advances straightforwardly can be improved.

Now, action of the personal watercraft 10 when it advances straightforwardly is described with reference to FIGS. 5(a) and 5(b).

FIGS. 5(a) and 5(b) are views illustrating action of the personal watercraft according to the present invention when it advances straightforwardly. In the following, description is given of an example wherein the personal watercraft 10 is a two-seater watercraft. However, the watercraft according to the present invention is not limited to a two-seater watercraft.

Referring to FIG. 5(a), two crew-members 50 ride on the seat 14 with the left and right feet 50a placed on the left and right foot decks 13, respectively, and one of the crew-members 50 grips the operation handle member 15 with the left and right hands 50b to steer the personal watercraft 10.

In this condition, as the operation handle member 15 is kept in a straightforwardly advancing condition, a water jet 51 is jetted rearwardly as indicated by an arrow mark ① from the steering nozzle 21 attached to the rear end of the water jet propeller 20 (shown in FIG. 1). As the water jet 51 is jetted, the personal watercraft 10 is advanced straightforwardly as indicated by an open arrow mark.

In FIG. 5(b), as the radius R1 of the arc of the keel 33 is made large to suppress the projecting amount of the keel 33, it is possible to prevent the keel 33 from being influenced by a side wave. Consequently, the personal watercraft 10 can be prevented from being rolled leftwardly or rightwardly by an influence of a side wave.

It is to be noted that, if the speed of the personal watercraft is raised while it is advancing straightforwardly, then it enters a gliding state, in which only the rear half portion of the body 11 touches with the water while the front half portion of the body 11 is spaced away from the water.

When ripples are present on the water, the ripples hit only the rear half portion of the body 11. However, if a high wave is present on the water, then the wave hits also the front portion of the body 11. Since the front half portion of the body 11 is formed such that the radius of the arc of the keel gradually decreases forwardly, the front half portion, which is hit by a high wave, is superior in plowing property and the impact provided from the high wave can be reduced, by which the driving comfortability is improved.

Subsequently, action of the personal watercraft 10 upon turning is described with reference to FIGS. 6(a), 6(b), 7(a), and 7(b).

FIGS. 6(a) and 6(b) are views illustrating first action when the personal

watercraft according to the present invention is turned.

Referring to FIG. 6(a), two crew-members 50 ride on the seat 14 with the left and right feet 50a placed on the left and right foot decks 13, respectively, and one of the crew-members 50 grips the operation handle member 15 with the left and right hands 50b to steer the personal watercraft 10.

Thereupon, the crew-member 50 operates the operation handle member 15 in such a manner as indicated by an arrow mark ② to swingably move the steering nozzle 21. Consequently, the direction of the water jet jetted from the steering nozzle 21 is inclined as indicated by an arrow mark ③.

In FIG. 6(b), when the direction of the water jet jetted from the steering nozzle 21 is inclined as indicated by the arrow mark ③ (indicated in FIG. 6(a)), simultaneously the crew-member 50 (refer to FIGS. 5(a) and 5(b)) operates to steer the operation handle member 15 to a turning condition.

Here, since the center 34 of the arc of the keel 33 substantially coincides with the height of the position G of the center of gravity of the body 11, the personal watercraft 10 is inclined as indicated by an arrow mark ④ around the position G of the center of gravity.

FIGS. 7(a) and 7(b) are views illustrating second action of the personal watercraft according to the present invention when it is turned.

In FIG. 7(a), if the personal watercraft 10 is inclined as indicated by the arrow mark ④ (indicated in FIG. 6(b)) around the position G of the center of gravity and the personal watercraft 10 is kept in a state wherein it is inclined by a predetermined angle θ_1 , then the personal watercraft 10 can be turned suitably.

FIG. 7(b) is a graph illustrating the inclination time of the personal watercraft 10 when the personal watercraft 10 is turned. From this graph g1, it can be seen that the personal watercraft 10 is inclined over some time Δt from inclination starting time (t_1) to inclination ending time (t_2).

5

This indicates that, since the crew-member 50 steers so as to turn the personal watercraft 10 and the movement when the body 11 turns its direction and is pushed by water from a sideward direction so that the body 11 begins to be inclined is fast and thereafter the left and right inclined faces 35 and 37 extending respectively, continuously from the left and right sides 33a and 33b of the keel 33 linearly to the outer sides of the body 11 act as resistance, the personal watercraft 10 can be inclined over some period of time Δt .

15 Consequently, since the personal watercraft 10 can be inclined in accordance with a steering condition of the crew-member 50, the personal watercraft 10 can be inclined smoothly to the turning center side by a natural movement.

20 Accordingly, the personal watercraft 10 can be turned with the same sense as the sense of operation of a motorcycle, and the operability when the personal watercraft 10 is turned can be improved.

On the other hand, where the keel 55 indicated by imaginary lines in FIG. 4(a) is formed on the bottom, the keel 55 projects by a comparatively great amount downwardly from a middle portion of the bottom 102. Consequently, when the crew-member 50 steers the operation handle member 15 in order to turn the personal watercraft 10, the movement when the body 11 begins to be inclined is slow, and after the body 11 begins to be inclined, the personal watercraft 10 is inclined suddenly to the turning center side.

30

Consequently, since some displacement occurs between the steering of the crew-member 50 and the inclination movement of the body 11, the personal watercraft 10 cannot be inclined smoothly to the turning center side by a natural movement.

5

Accordingly, the personal watercraft 10 cannot be turned with the same sense as the sense of operation of a motorcycle.

It is to be noted that, while, in the embodiment described above, the personal watercraft 10 is a two-seater watercraft, the present invention is not limited to this, and similar effects can be achieved also with such personal watercrafts as a one-seater watercraft or a three-seater watercraft.

Further, while, in the embodiment described above, the personal watercraft 10, taking water jet propulsion wherein it is propelled by a water jet propeller as an example, is described, the propulsion for the watercraft is not limited to this.

The present invention exhibits the following effects due to the configuration described above.

According to the present invention, at the portion of the body rearwardly of the center of the body, the center of the arc of the keel substantially coincides with the height of the position of the center of gravity of the body. Consequently, the radius of the arc of the keel can be made large. As the radius of the arc of the keel becomes large, the keel can be prevented from projecting downwardly by a great amount from the bottom.

Where the projecting amount of the keel is suppressed in this manner, the keel is less likely to be influenced by a side wave so that the body can be prevented from being rolled leftwardly or rightwardly by an influence of a side wave.

Further, since the keel does not project downwardly by a great amount from the bottom and the center of the arc of the keel substantially coincides with the height of the position of the center of gravity of the body, when a crew-member performs a steering operation upon turning, the body can be inclined to the center of the turning movement in accordance with the steering condition.

Consequently, since the body can be inclined smoothly toward the center of the turning movement by a natural movement, the personal watercraft can be turned with a sense similar to the sense of operation of a motorcycle.

According to an embodiment of the invention, since, at the portion of the body forwardly of the center of the body, the radius of the arc of the keel gradually decreases forwardly, the keel at the portion of the body forwardly of the center of the body can be made project by a comparatively great amount from the bottom.

Consequently, since the plowing property by the keel when the personal watercraft advances straightforwardly can be improved, when the body is hit by a high wave while the personal watercraft glides, the impact provided to the body can be suppressed low and improvement in the driving comfortability can be anticipated.

Although various preferred embodiments of the present invention have been described herein in detail, it will be appreciated by those skilled in the art, that variations may be made thereto without departing from the spirit of the invention or the scope of the appended claims.

THE EMBODIMENTS OF THE INVENTION IN WHICH AN EXCLUSIVE PROPERTY OR PRIVILEGE IS CLAIMED ARE DEFINED AS FOLLOWS:

1. A personal watercraft comprising a saddle type seat extending
5 in a forward and backward direction at a middle portion of a deck of a
body, an operation handle member provided forwardly of said seat, a pair
of foot decks formed on the opposite sides of said seat, and a keel provided
at a middle portion of a bottom of said body and extending from a bow to a
stern, said keel being formed in an arc, characterized in that the center of
10 the arc of said keel extending in the forward and backward direction of said
body substantially coincides with the height of the position of the center of
gravity of said body at a location rearwardly of the center of said body.

2. A personal watercraft according to claim 1, characterized in
15 that the radius of the arc of said keel gradually decreases forwardly at a
location forwardly of the center of said body.

[FIG. 1]

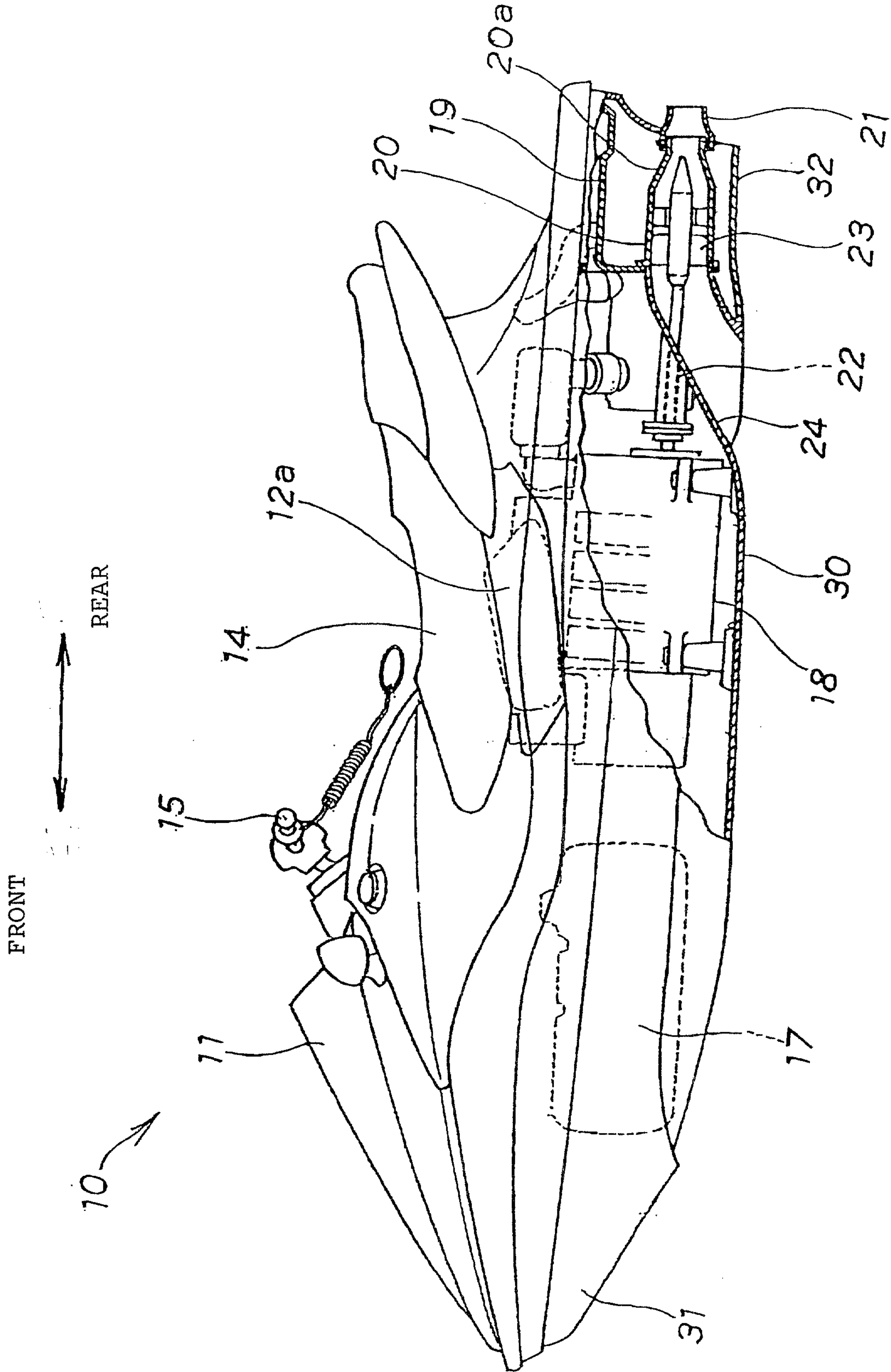

[FIG. 2]

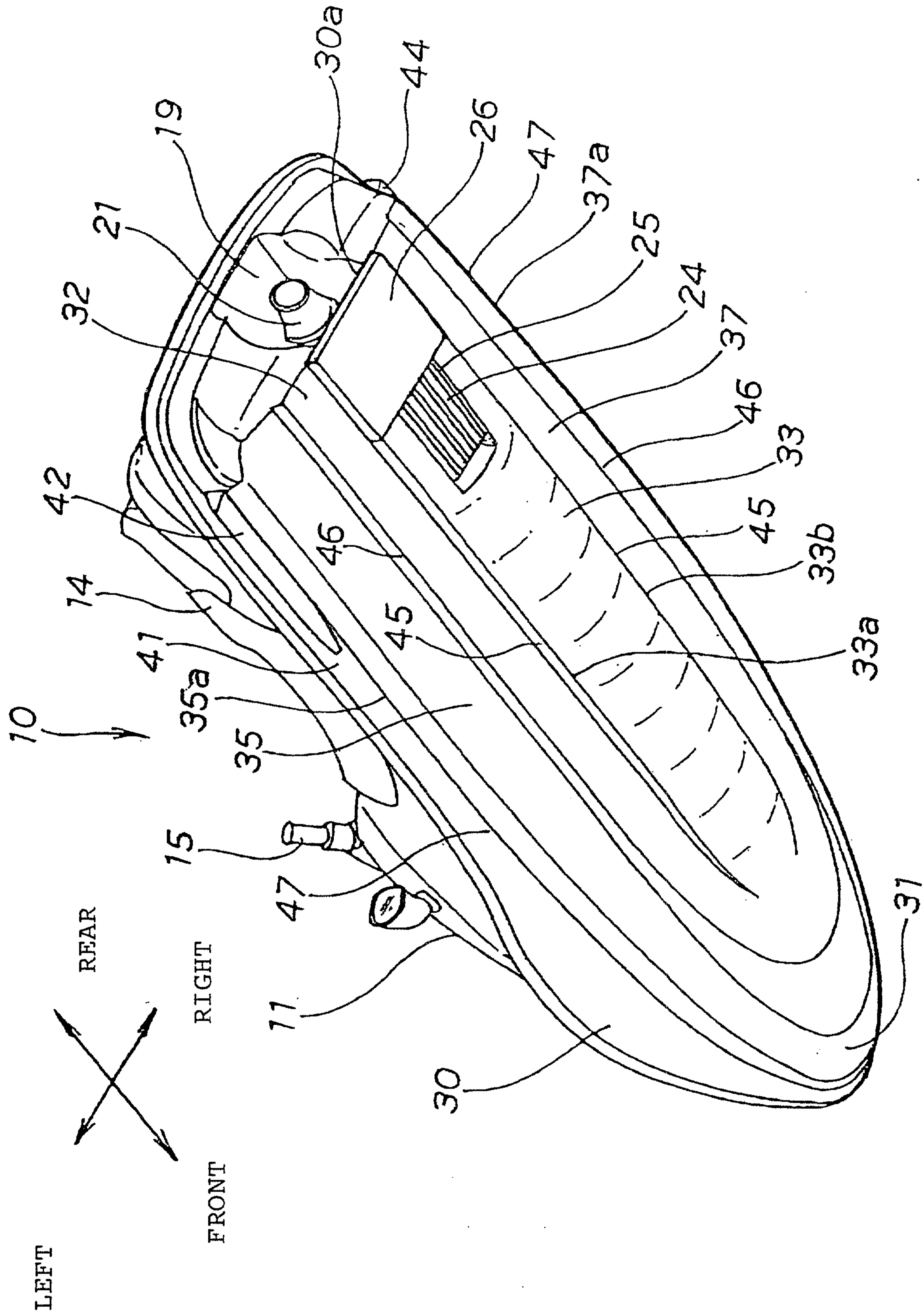

[FIG. 3]

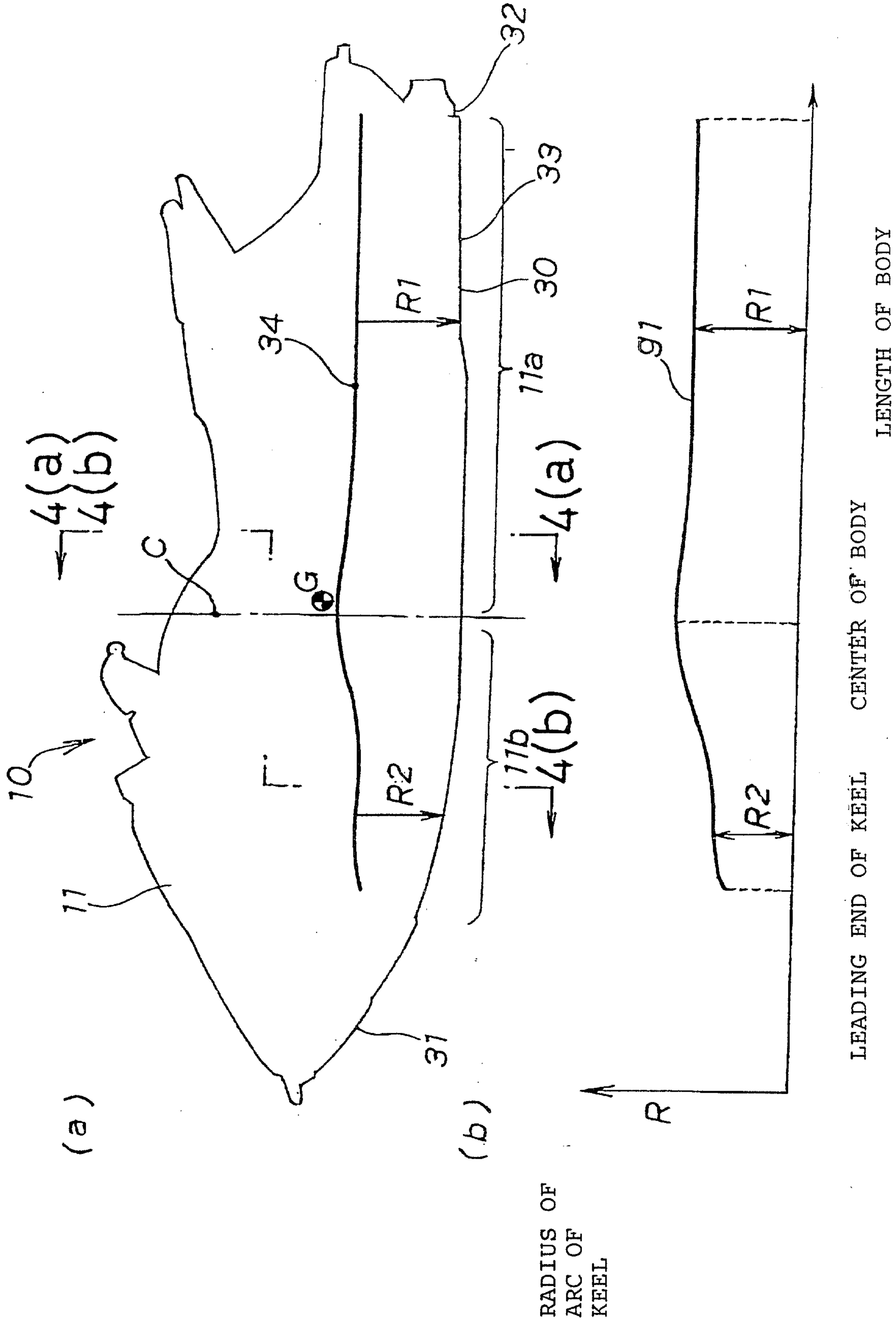

TRAILING END OF KEEL

CENTER OF BODY

LENGTH OF BODY

LEADING END OF KEEL

R

[FIG. 4]

(a)

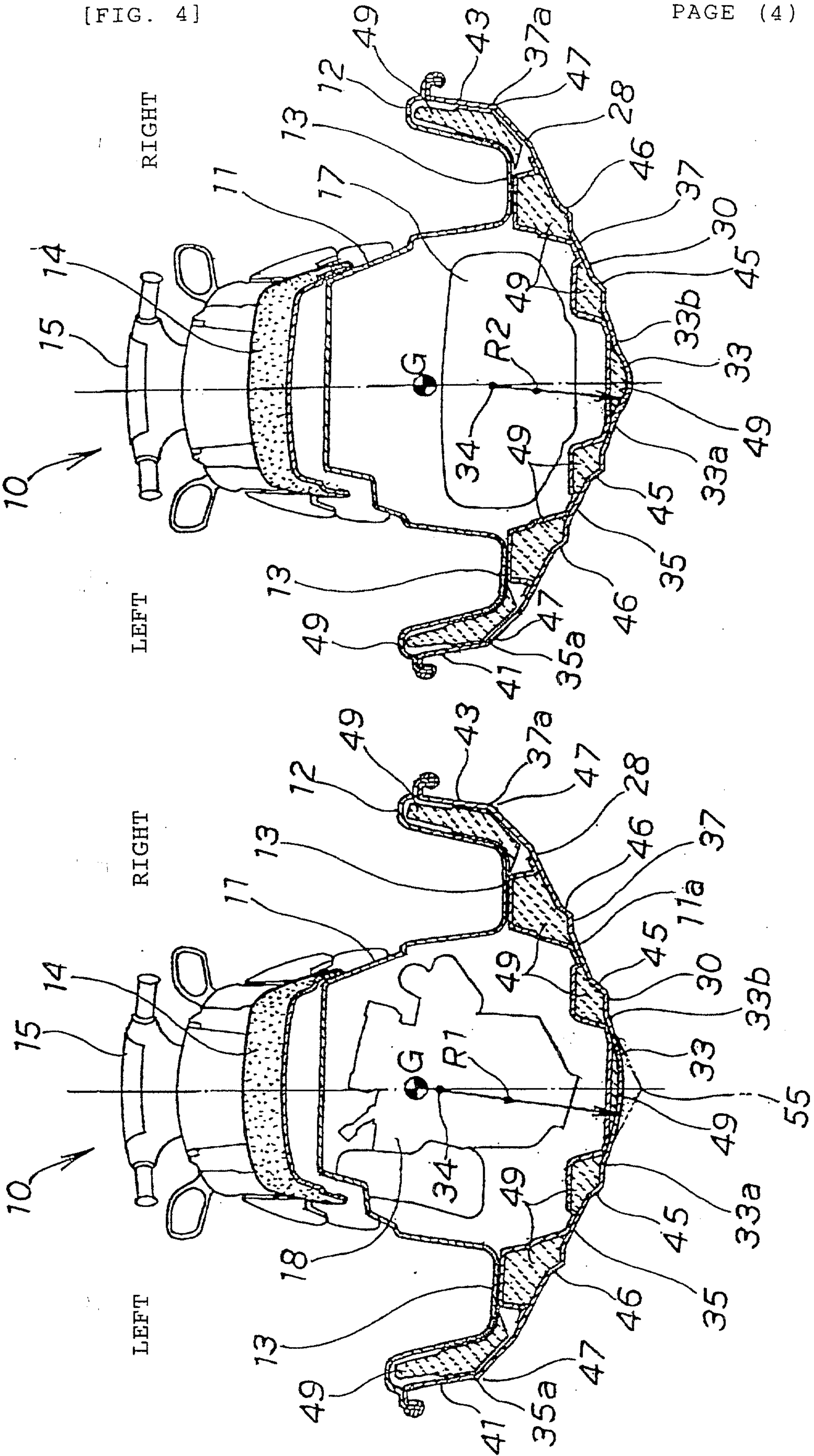

(b)

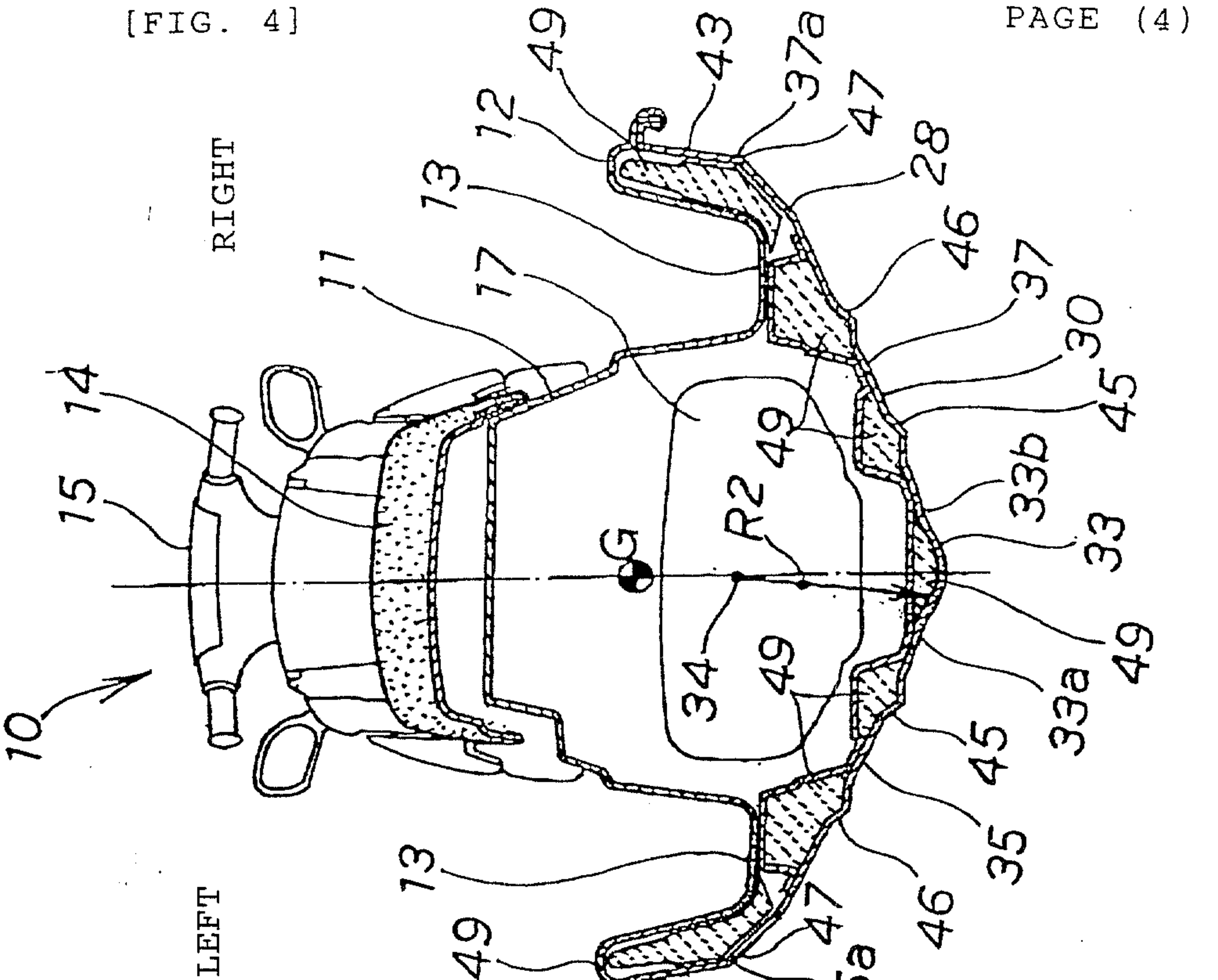

[FIG. 5]

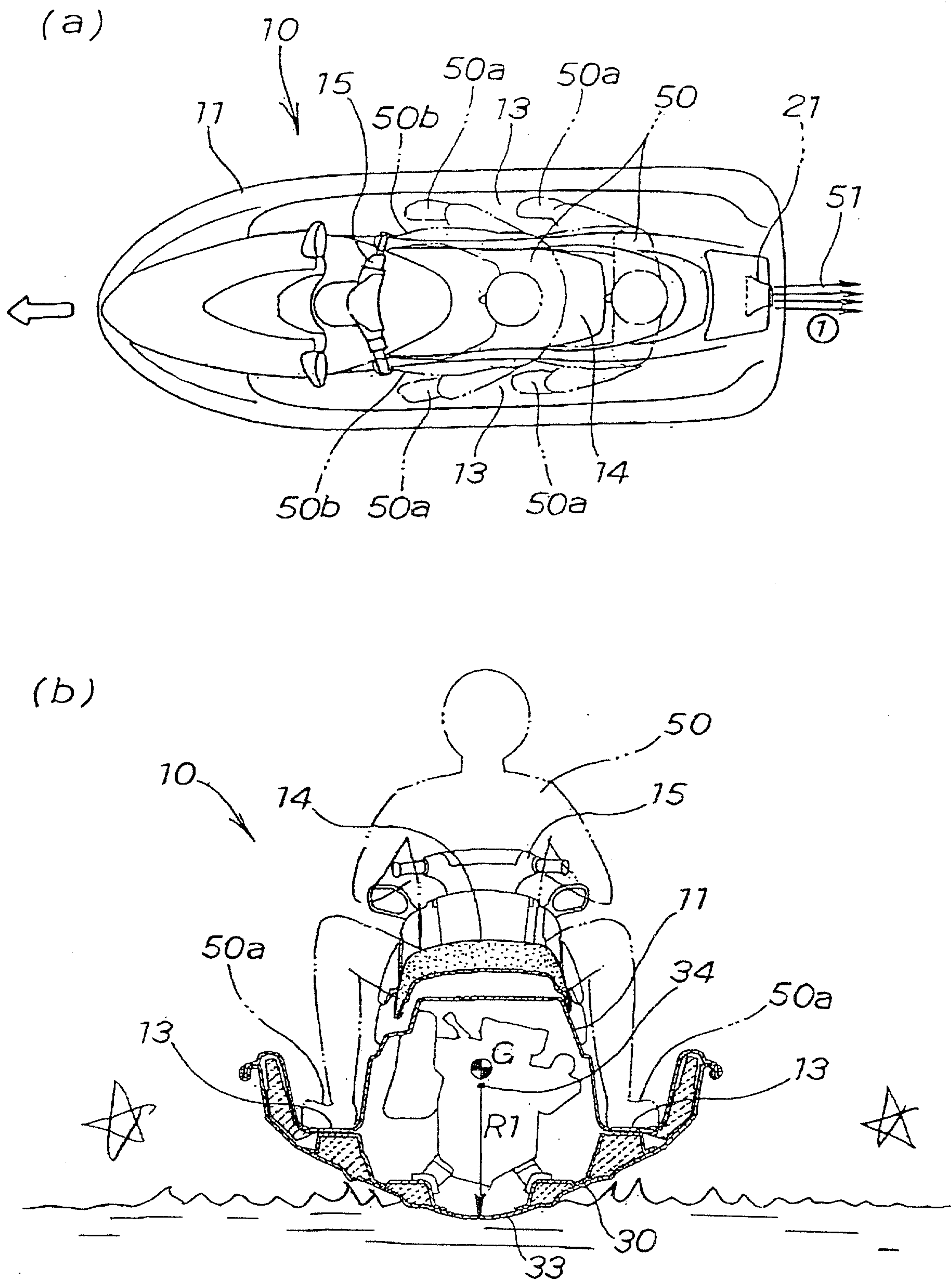

[FIG. 6]

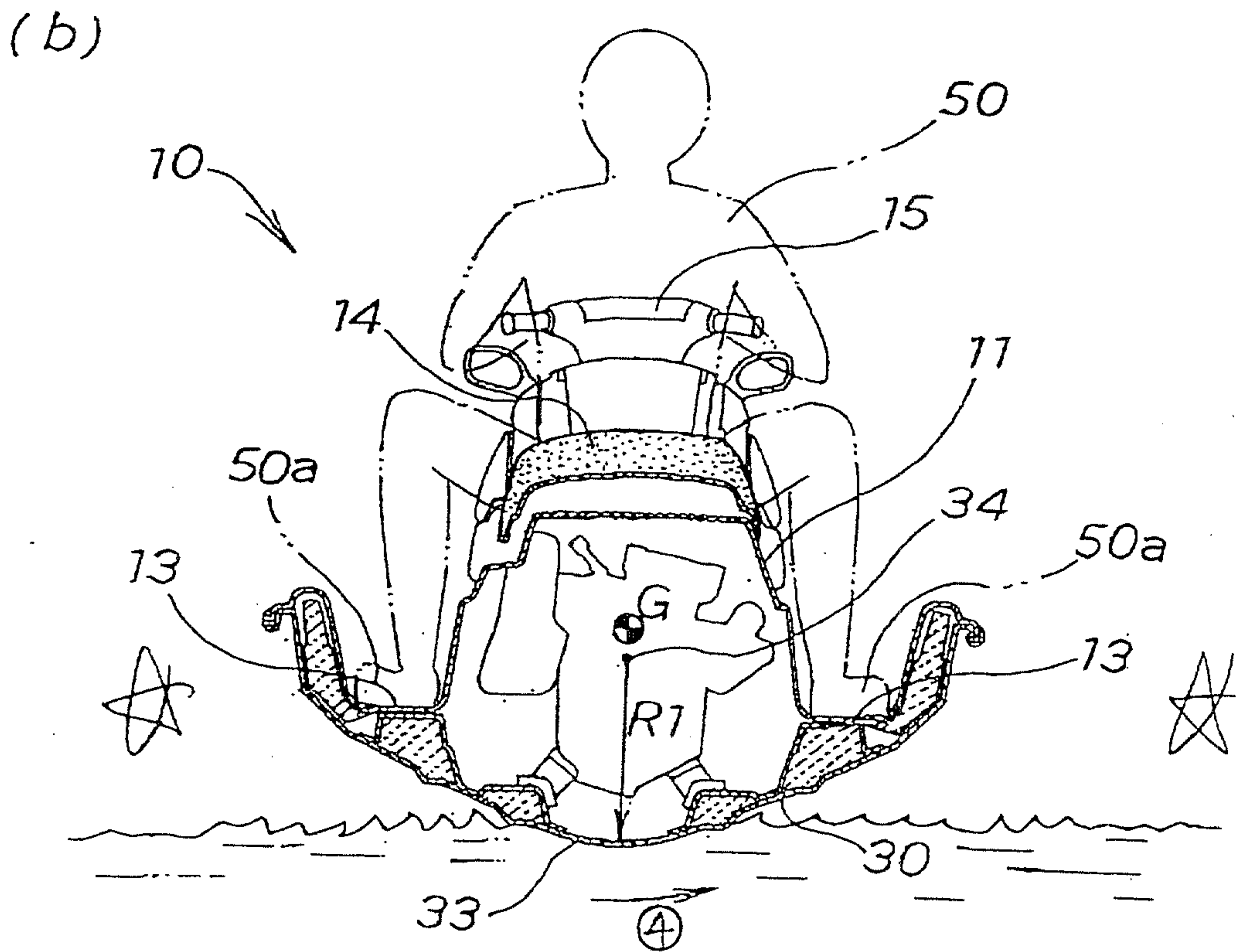
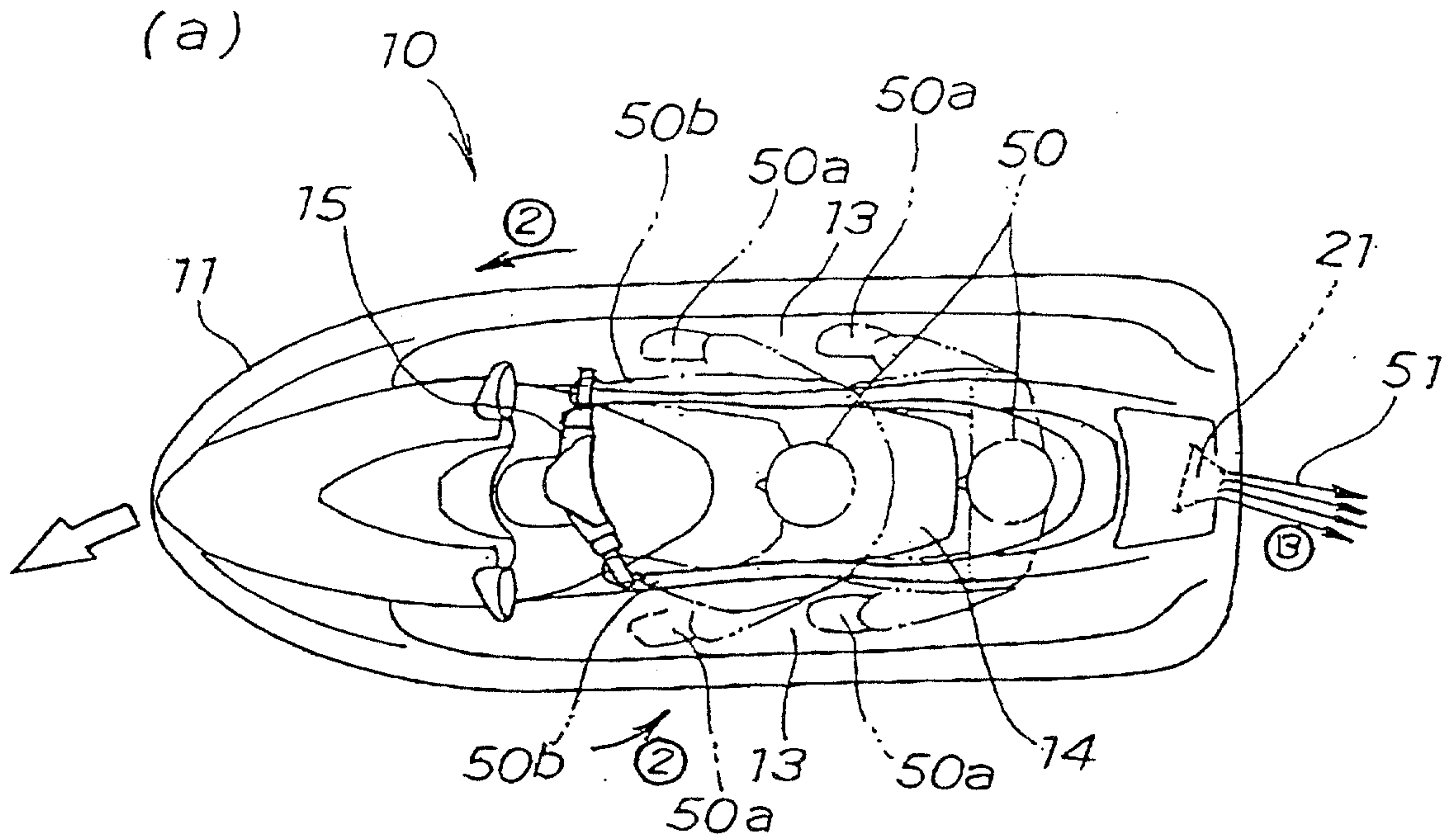

[FIG. 8]

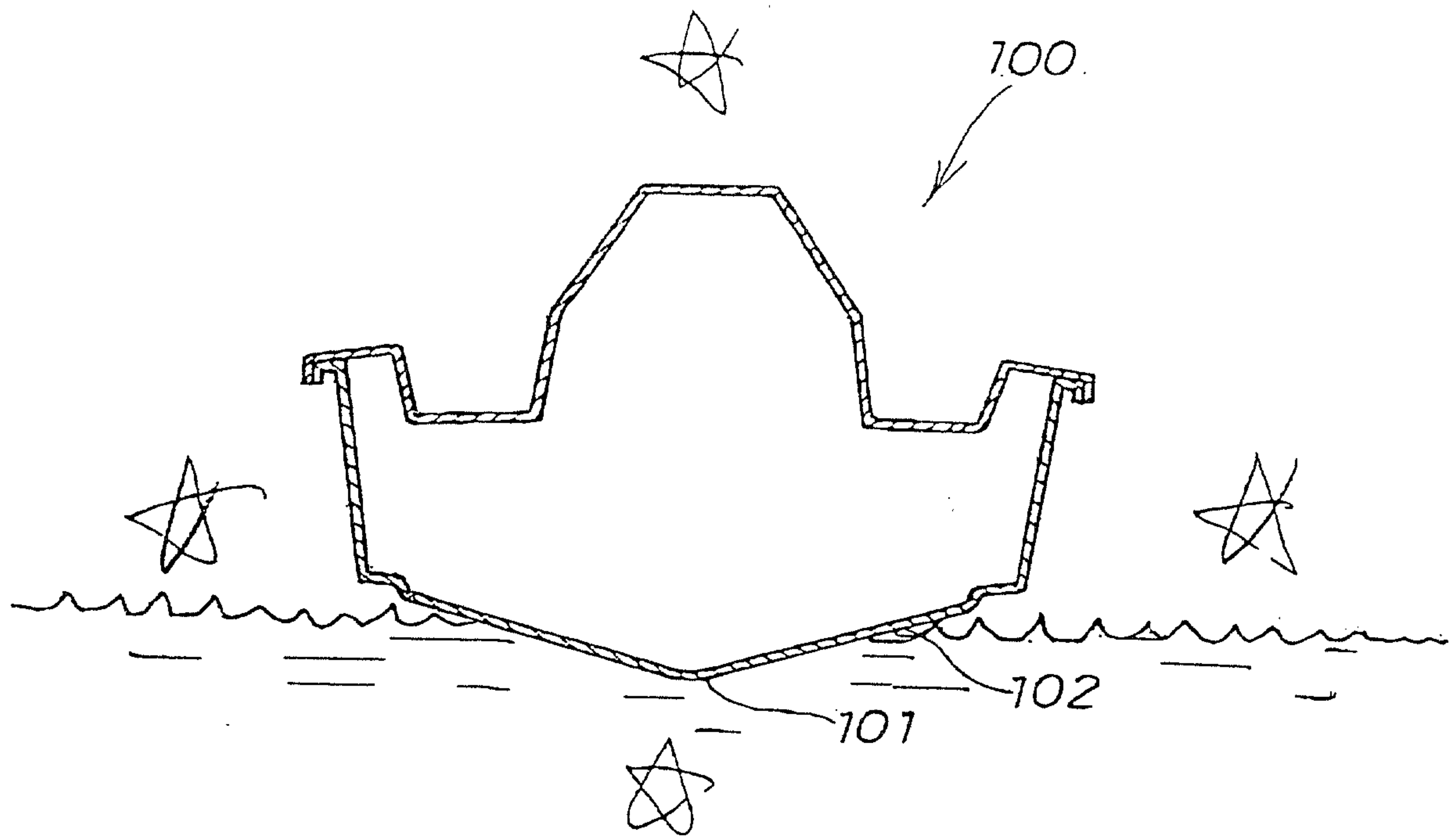

[FIG. 9]

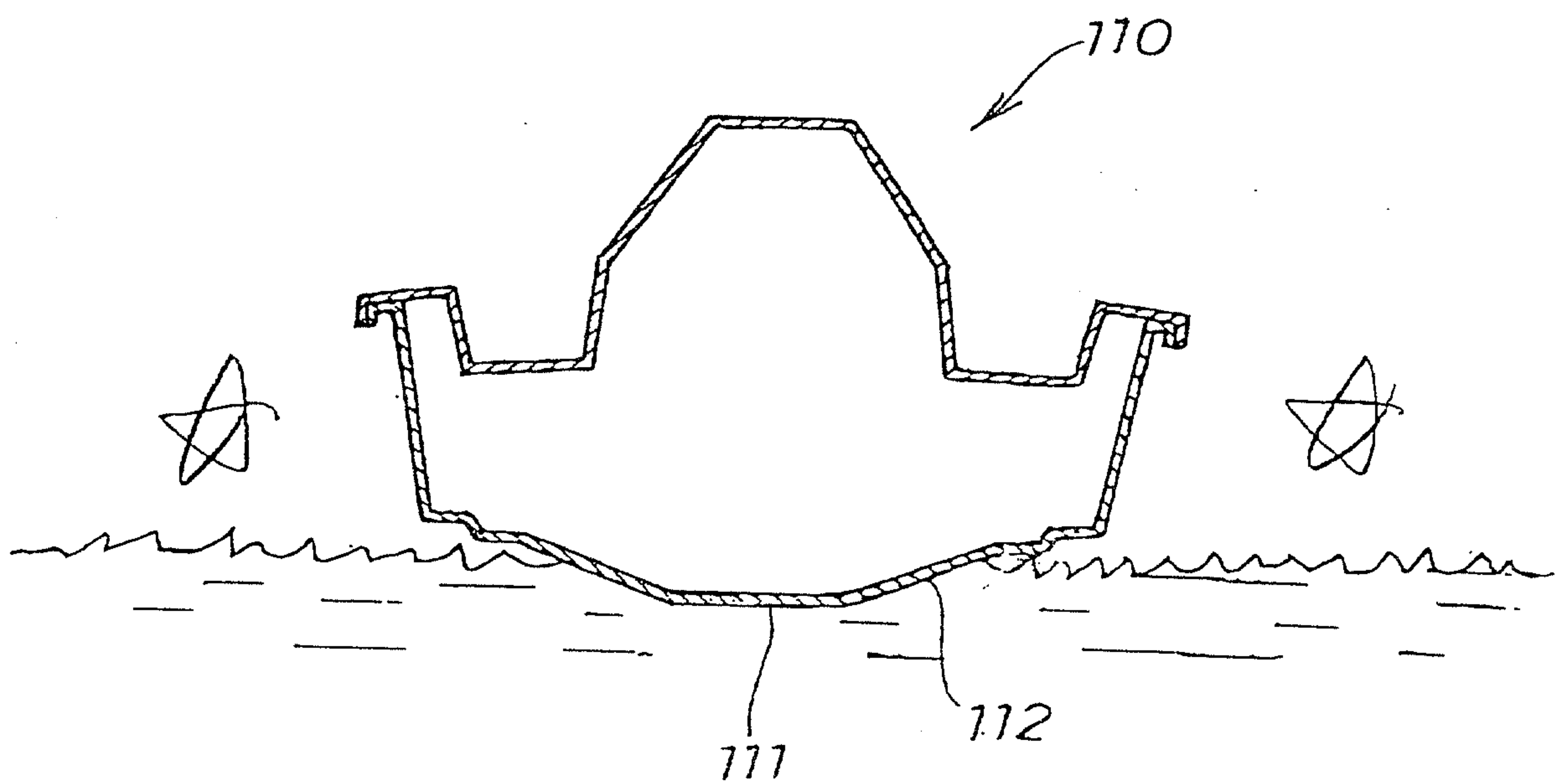

[FIG. 10]

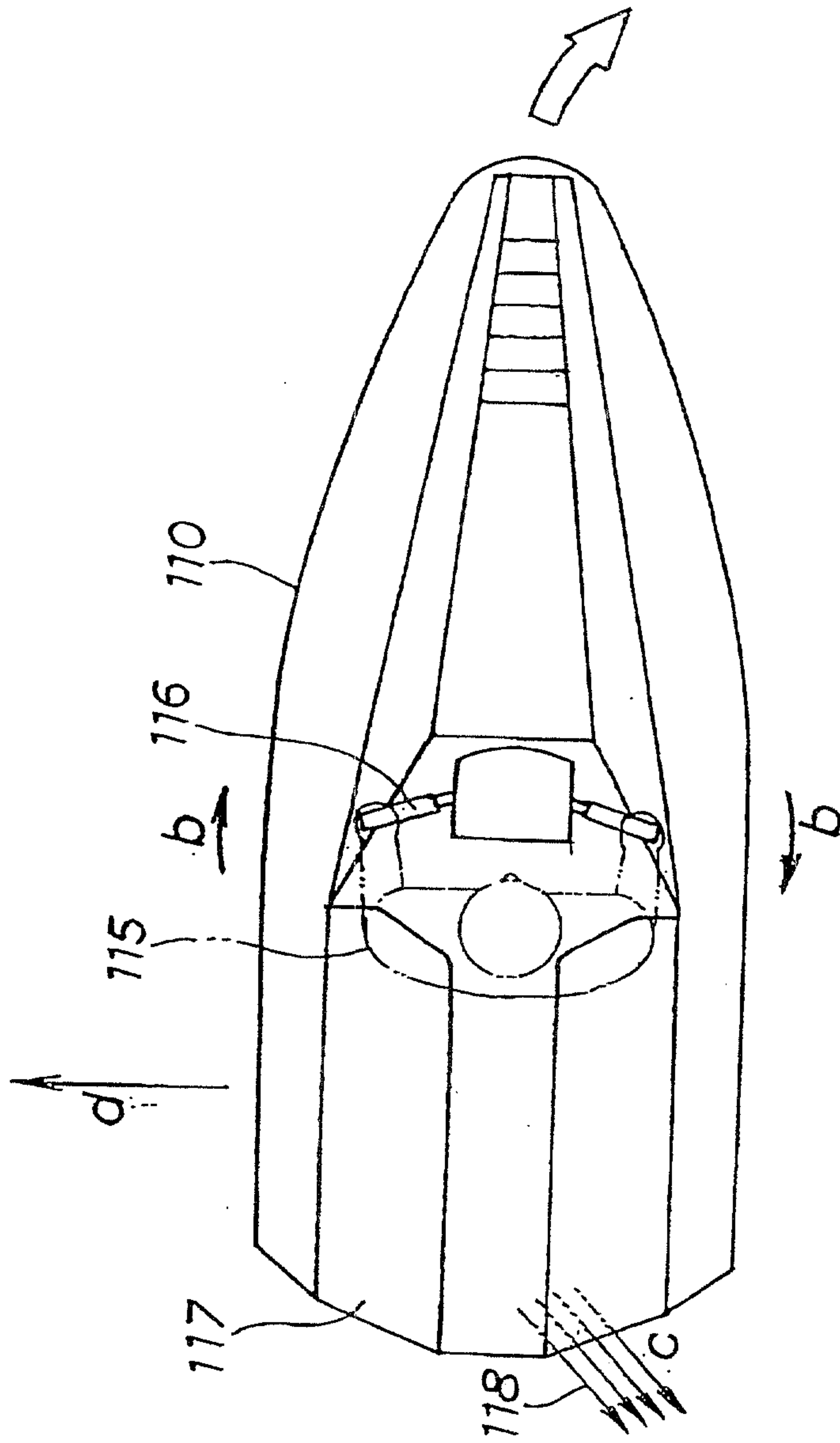

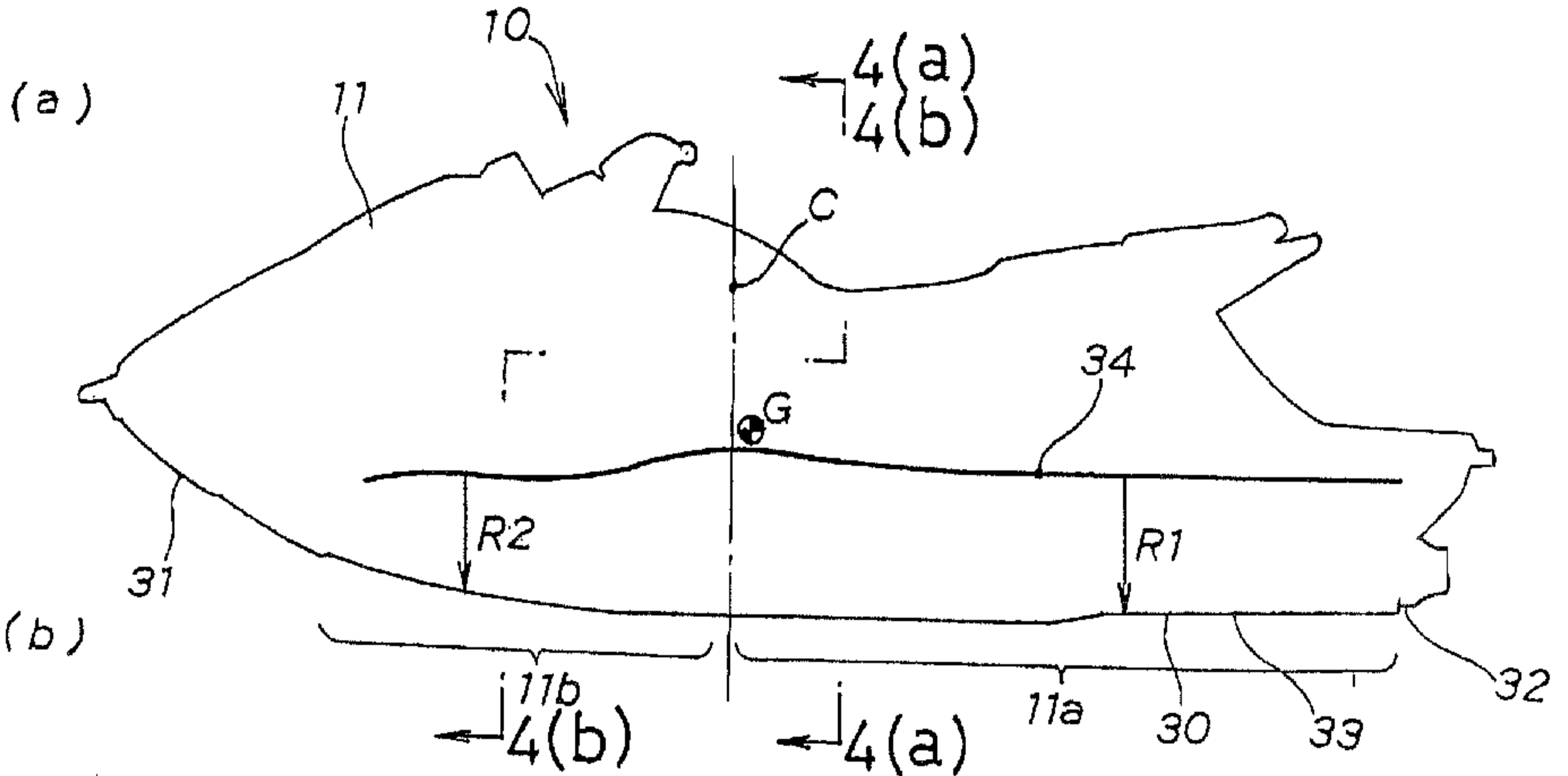

RADIUS OF
ARC OF
KEEL

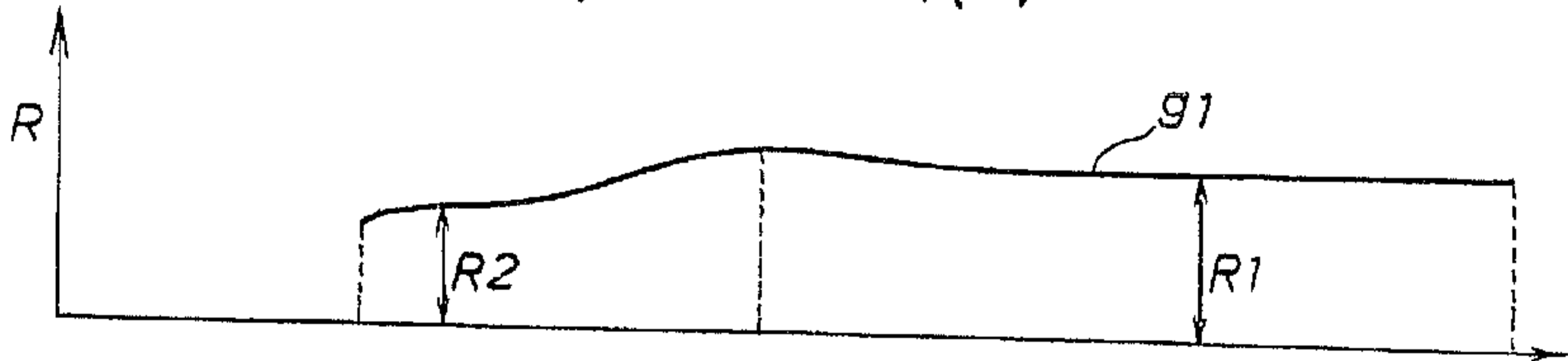
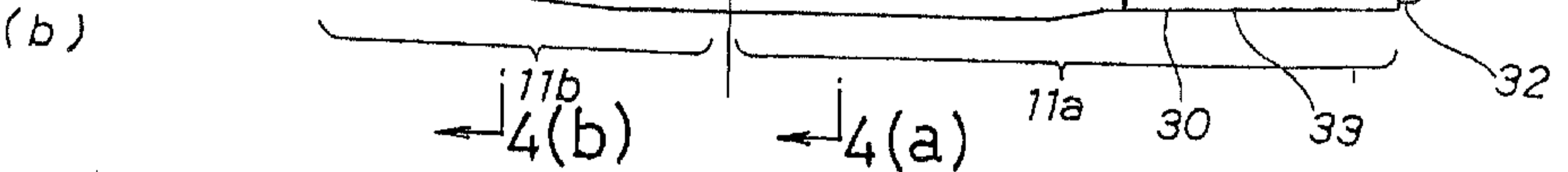

LEADING END OF KEEL

CENTER OF BODY

LENGTH OF BODY

TRAILING END OF KEEL