



- (51) International Patent Classification:  
A61B 17/00 (2006.01)
- (21) International Application Number:  
PCT/US2014/045489
- (22) International Filing Date:  
3 July 2014 (03.07.2014)
- (25) Filing Language: English
- (26) Publication Language: English
- (30) Priority Data:  
61/842,879 3 July 2013 (03.07.2013) US  
14/322,589 2 July 2014 (02.07.2014) US
- (71) Applicant: SPINE INNOVATION, INC. [US/US]; 101 Acacia Avenue, Suite 116, Solana Beach, CA 92075 (US).
- (72) Inventors: EASTLACK, Robert; 5265 Amber View Point, San Diego, CA 92130 (US). BRUFFEY, James; 3435 Fenelon Street, San Diego, CA 92106 (US). BAWA, Maneesh; 1064 Diamond Street, San Diego, CA 92109 (US). BOWMAN, Brian; 3349 Del Rio Court, Carlsbad, CA 92009 (US). ARNOLD, Benjamin; 10755 New Grove Trail, #78, San Diego, CA 92130 (US). PAGANELLI, Jude; 4719 Reedley Terrace, San Diego, CA 92130 (US).
- (74) Agents: PORTNOW, Douglas et al.; Wilson Sonsini Goodrich & Rosati, 650 Page Mill Road, Palo Alto, CA 94304-1050 (US).

(81) Designated States (unless otherwise indicated, for every kind of national protection available): AE, AG, AL, AM, AO, AT, AU, AZ, BA, BB, BG, BH, BN, BR, BW, BY, BZ, CA, CH, CL, CN, CO, CR, CU, CZ, DE, DK, DM, DO, DZ, EC, EE, EG, ES, FI, GB, GD, GE, GH, GM, GT, HN, HR, HU, ID, IL, IN, IR, IS, JP, KE, KG, KN, KP, KR, KZ, LA, LC, LK, LR, LS, LT, LU, LY, MA, MD, ME, MG, MK, MN, MW, MX, MY, MZ, NA, NG, NI, NO, NZ, OM, PA, PE, PG, PH, PL, PT, QA, RO, RS, RU, RW, SA, SC, SD, SE, SG, SK, SL, SM, ST, SV, SY, TH, TJ, TM, TN, TR, TT, TZ, UA, UG, US, UZ, VC, VN, ZA, ZM, ZW.

(84) Designated States (unless otherwise indicated, for every kind of regional protection available): ARIPO (BW, GH, GM, KE, LR, LS, MW, MZ, NA, RW, SD, SL, SZ, TZ, UG, ZM, ZW), Eurasian (AM, AZ, BY, KG, KZ, RU, TJ, TM), European (AL, AT, BE, BG, CH, CY, CZ, DE, DK, EE, ES, FI, FR, GB, GR, HR, HU, IE, IS, IT, LT, LU, LV, MC, MK, MT, NL, NO, PL, PT, RO, RS, SE, SI, SK, SM, TR), OAPI (BF, BJ, CF, CG, CI, CM, GA, GN, GQ, GW, KM, ML, MR, NE, SN, TD, TG).

**Published:**

- with international search report (Art. 21(3))
- before the expiration of the time limit for amending the claims and to be republished in the event of receipt of amendments (Rule 48.2(h))

(54) Title: METHODS AND APPARATUS FOR AN INSERTION GUIDE DEVICE

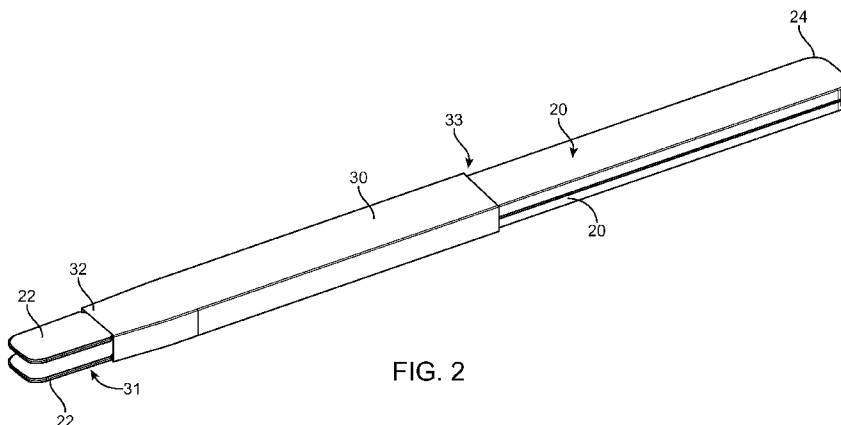

FIG. 2

(57) Abstract: A delivery instrument for placing an interbody implant into an intervertebral space of a patient comprises a plurality of elongated plates disposed adjacent one another. Each elongated plate has a proximal portion and a distal portion. The distal portion is sized and shaped to fit into the intervertebral space, and is configured to engage a vertebral body in the intervertebral space. An expandable member is coupled to the plurality of elongated plates so as to form an enclosed tube that is sized and shaped to receive the interbody implant. The expandable member allows for translation of the plurality of elongated plates relative to one another as the interbody implant passes through the tube.



## METHODS AND APPARATUS FOR AN INSERTION GUIDE DEVICE

### CROSS-REFERENCE

**[0001]** The present application is a PCT of, and claims the benefit of US Patent Application No. 14/322,589 (Attorney Docket No. 44057-705.201) filed July 2, 2014 which is a non-provisional of, and claims the benefit of US Provisional Patent Application No. 61/842,879 (Attorney Docket No. 44057-705.101) filed on July 3, 2013; the entire contents of which are incorporated herein by reference.

**[0002]** The present application is related to US Patent Application No. 14/322,702 (Attorney Docket No. 44057-706.201) filed July 2, 2014; the entire contents of which are incorporated herein by reference.

### BACKGROUND OF THE INVENTION

**[0003]** 1. Field of the Invention. The present invention generally relates to medical devices and methods, and more particularly relates to delivery instruments and methods for deploying an interbody fusion implant into an intervertebral disc space.

**[0004]** Various interbody fusion implants (also referred to as interbody fusion devices) may be implanted in the intervertebral disc space. These devices facilitate fusion of the adjacent vertebrae together. Depending on the size of the interbody fusion device and the corresponding delivery instrument, a surgeon may have to remove bone from the surrounding vertebrae in order to provide adequate space. Clearly, it would be desirable if bone removal could be minimized or eliminated all together. Moreover, adjacent tissue may also need to be retracted or removed, and it would be desirable to minimize or eliminate this as well. Also, insertion of the implant often requires distraction of the vertebrae, therefore it would be desirable to provide a low profile implant that minimizes the amount of distraction required.

**[0005]** Newer interbody fusion devices are being developed which have a smaller more compact profile for delivery and a larger expanded profile after deployment. The smaller delivery size facilitates delivery, and the larger deployed configuration facilitates support and fusion of the bone. Therefore, it would be desirable to provide improved delivery instruments which can accurately and safely deliver and deploy interbody fusion devices including those that have collapsed configurations for delivery and expanded configurations after deployment. At least some of these objectives will be satisfied by the devices and methods disclosed below.

**[0006]** 2. Description of the Background Art. The following US patents and US patent publications are related to interbody fusion devices and their delivery: 6,652,533; 3,486,505; 2011/0071634; 7,896,884; 7,625,379; 6,755,841; 5,431,658; and RE43317.

### SUMMARY OF THE INVENTION

**[0007]** The present invention generally relates to medical devices and methods, and more particularly relates to delivery instruments and methods for deploying an interbody fusion implant into an intervertebral disc space.

**[0008]** In a first aspect of the present invention, a delivery instrument for facilitating the placement of an interbody implant into an intervertebral space of a patient comprises a plurality of elongated plates disposed adjacent one another. Each elongated plate has a proximal portion and a distal portion. The distal portion of each elongated plate is sized and shaped to fit into the intervertebral space, and also the distal portion of each elongated plate is configured to engage a vertebral body in the intervertebral space. An expandable member is coupled to the plurality of elongated plates so as to form an enclosed tube for at least a portion of the length of the plurality of elongated plates. The enclosed tube is sized and shaped to receive the interbody implant. The expandable member allows for translation of the plurality of elongated plates relative to one another as the interbody implant passes through the tube.

**[0009]** The expandable member may be an elastomeric tube that is disposed over the plurality of elongated plates. The expandable member may comprise two or more flexible sheets of resilient material that extend from one elongated plate to another elongated plate. The plurality of elongated plates may have a geometry that is configured to engage the interbody implant passing through the tube, and the plurality of elongated plates may have a geometry that guides the interbody implant into the intervertebral space. The geometry that engages the interbody implant may comprise a plurality of rails extending from the plurality of elongated plates.

**[0010]** The plurality of elongated plates may be expandable to allow the delivery instrument to expand in one or multiple directions in order to accommodate various sizes of interbody implants. The plurality of elongated plates may have a longitudinally oriented slit located therealong, and the slit may be configured to allow the plurality of plates to expand and contract. The longitudinally oriented slit may comprise a stress relief feature. The plurality of plates may be coupled together adjacent their proximal portion.

**[0011]** At least one of the plurality of elongated plates may comprise a finger loop adjacent a proximal end thereof, and the finger loop may be configured to facilitate grasping by an operator's finger. The delivery instrument may further comprise a stop element disposed adjacent a distal portion of at least one of the plurality of elongated plates. The stop element may be configured to limit insertion of the delivery instrument into the intervertebral space.

**[0012]** In another aspect of the present invention, a system for delivering an implant to an intervertebral space of a patient comprises the delivery instrument previously described above as well as an interbody implant.

**[0013]** In still another aspect of the present invention, a method for delivering an interbody implant into an intervertebral space between adjacent vertebral bodies of a patient comprises providing a

delivery instrument having a plurality of elongated plates disposed adjacent one another and coupled together with an expandable member, and advancing the interbody implant along a tube formed by the plurality of elongated plates and the expandable member. The method also comprises translating the plurality of elongated plates relative to one another as the interbody implant advances along the tube, ejecting the interbody implant from the delivery device, and returning the elongated plates to an unbiased configuration after the interbody implant has been ejected.

**[0014]** Translating the plurality of elongated plates may comprise moving the plurality of plates away from one another, or expanding or collapsing the expandable member. The expandable member may comprise an elastomeric tube that is disposed over the plurality of elongated plates.

**[0015]** Advancing the interbody implant may comprise guiding the interbody implant along the tube with a plurality rails extending from the plurality of elongated plates. A stress relief feature may be included in one or more of the plurality of elongated plates, and the method may further comprise relieving stress in the delivery instrument as the interbody implant is translated therealong.

**[0016]** Translating the plurality of elongated plates may comprise expanding or contracting a slit disposed in at least one of the plurality of elongated plates. The plurality of elongated plates may be coupled to one another adjacent a proximal portion thereof, and translating the plurality of elongated plates may comprise pivoting the plurality of elongated plates relative to the proximal portion. Ejecting may comprise disposing the interbody implant in the intervertebral space. The method may further comprise engaging a distal portion of the plurality of elongated plates with the vertebral bodies.

**[0017]** The method may further comprise grasping the delivery device by inserting one or more fingers in a finger loop disposed on a proximal portion of at least one of the plurality of elongated plates. The method may also further comprise advancing the plurality of elongate plates into the intervertebral space, and limiting penetration of the plurality of elongate plates into the intervertebral space. This may be accomplished by engaging a stop element disposed on at least one of the plurality of elongate plates against an edge of at least one of the adjacent vertebral bodies.

**[0018]** These and other embodiments are described in further detail in the following description related to the appended drawing figures.

#### **INCORPORATION BY REFERENCE**

**[0019]** All publications, patents, and patent applications mentioned in this specification are herein incorporated by reference to the same extent as if each individual publication, patent, or patent application was specifically and individually indicated to be incorporated by reference.

#### **BRIEF DESCRIPTION OF THE DRAWINGS**

**[0020]** The novel features of the invention are set forth with particularity in the appended claims. A better understanding of the features and advantages of the present invention will be obtained by

reference to the following detailed description that sets forth illustrative embodiments, in which the principles of the invention are utilized, and the accompanying drawings of which:

- [0021] Figure 1 is a perspective view of an elongated plate component;
- [0022] Figure 2 is a perspective view of an insertion guide device, using the elongated plate in Figure 1, in the collapsed state;
- [0023] Figure 3 is a perspective view of the insertion guide device in Figure 2 in an expanded state;
- [0024] Figure 4 is a perspective view of an elongated plate component;
- [0025] Figure 5 is a perspective view of an insertion guide device, using the elongated plate in Figure 4, in the collapsed state;
- [0026] Figure 6 is a perspective view of the insertion guide device in Figure 5 in an expanded state;
- [0027] Figure 7 is a perspective view of an elongated plate component;
- [0028] Figure 8 is a perspective view of an insertion guide device, using the elongated plate in Figure 7, in the collapsed state;
- [0029] Figure 9 illustrates an interbody implant coupled to the insertion guide device;
- [0030] Figures 10A-10F illustrate insertion of the insertion guide device into the intervertebral disc space and delivery of an interbody implant; and
- [0031] Figures 11A-11B illustrate a pusher element for pushing an interbody implant from the insertion guide device.
- [0032] Figure 12A illustrates a perspective view of another exemplary embodiment of an elongated plate used in an insertion guide device.
- [0033] Figure 12B is a side view of Figure 12A.
- [0034] Figure 13A illustrates a perspective view of an insertion guide device using the elongated plate in Figure 12A and in the collapsed configuration.
- [0035] Figure 13B illustrates the embodiment of Figure 13A in the expanded configuration.
- [0036] Figure 14 is a perspective view of the insertion guide device of Figure 13A inserted into the intervertebral space.
- [0037] Figure 15A illustrates a perspective view of another exemplary embodiment of an elongated plate that may be used in an insertion guide device.
- [0038] Figure 15B is a side view of Figure 15A.
- [0039] Figure 16A illustrates a perspective view of an insertion guide device using the elongated plate in Figure 15A and Figure 12A, and in the collapsed configuration.
- [0040] Figure 16B illustrates the embodiment of Figure 16A in the expanded configuration.
- [0041] Figure 17 illustrates the insertion guide device of Figure 16A inserted into the intervertebral disc space.

**DETAILED DESCRIPTION OF THE INVENTION**

**[0042]** Specific embodiments of the disclosed device, delivery system, and method will now be described with reference to the drawings. Nothing in this detailed description is intended to imply that any particular component, feature, or step is essential to the invention.

**[0043]** Figure 1 shows the elongated plate 20 with optional rails 21 extending outward from the elongated plate, to guide the implant into the disc space. The rails 21 extend up to the distal portion 22 of the elongated plate 20 that enters the disc space. The rails 21 end prior to the distal portion 22 of the elongated plate 20 in order to decrease the width of the elongated plate 20 that has to pass by the neural elements and into the disc space. The rails 21 are set at a distance apart to match the width of the implant being passed through it further optimizing the width of the elongated plate 20 so that it is as narrow as possible (low profile) as it passes by the neural elements. Notch 23, is an optional feature in the elongated plate 20 to allow for the engagement of the expandable member 30. This notch 23 prevents the axial migration of the expandable member 30 along the length of the elongated member 20. The elongated plate 20 may be made out of a variety of materials including, but not limited to, metals such as stainless steel or aluminum, carbon fiber, other composite materials, polymers such as ABS, and Radel™.

**[0044]** Two of the elongated plates 20 are shown in Figure 2 joined by an expandable member 30 in one exemplary embodiment of the device. In this configuration the distal portion of the device 31 that enters the disc space is in a collapsed configuration with each distal portion 22 of the elongated plates 20 adjacent or engaged with one another and being positioned such that they can engage the endplates of the adjacent vertebral bodies in a collapsed disc space. In this embodiment the expandable member 30 has a distal end 32 that doesn't enter into the disc space, in addition, the proximal end 33 of the expandable member 30 does not extend to the proximal end 24 of the elongated member 20. The expandable member 30 may be made of a variety of different materials including, but not limited to, polyurethane, polyisoprene, and latex.

**[0045]** In Figure 3, the device is shown in an expanded state with the distal end of the device 31 aiding in distraction of the disc space and the expandable member 30 being stretched to accommodate the increased distance between the elongated plates 20. The distal ends of elongated members 20 are separated from one another by a gap and displaced apart relative to the collapsed configuration.

**[0046]** Figure 4 shows another exemplary embodiment of the elongated plate 40. In this iteration there are rails 41 extending outward from the plate 40 and that run the length of the elongated plate 40 terminating only where the distal end 42 enters the disc space. The major addition in this embodiment of the design is the ability of the elongated plate 40 to expand to accommodate varying width implants. This expansion is accommodated by the split or slot 43 in the elongated plate 40 that runs from the proximal end 47 to the distal end 42. The split 43 runs out of the lateral edge 45 of the elongated plate 40 allowing for a solid surface within the disc space at the distal end 42 for better distraction of the disc space and a decreased potential for subsidence of the elongated plate 40 into the

endplate. The rails 41 have a tapered portion 44 that allow for the insertion of a wide implant at the proximal end 47 prior to the expansion of the elongated plate 40. Additionally, the split 43 in the elongated plate 40 has a stress relief cut 46 near the proximal end 47. In this embodiment, the stress relief 46 is a circular through hole in the elongated plate. This version of the elongated plate 40 is shown as part of an assembled device in Figure 5. In this embodiment of the device, two elongated plates 40 are joined by the expandable member 50.

**[0047]** Figure 5 shows the device in its collapsed state with the little distance between the elongated plates 40 at the distal end of the device 51. This same embodiment of the device is shown in Figure 6 in an expanded state with a distracted distal end of the construct 51. The top elongated plate is substantially the same as the bottom elongated plate.

**[0048]** Figure 7 shows another preferred embodiment of the elongated plate 60. In this embodiment, the elongated plates are joined at the proximal end 61. Similar to the previous embodiment 40, this embodiment has a split 62 or slot to allow for expansion in width, a tapered portion 60, a lateral run out 65 of the split 62, and a flat surface that contacts the vertebral end plates at the distal end 66. This embodiment of the elongated plate 60 also has a step 64 to help constrain the expanding member 70 as seen in Fig. 8.

**[0049]** Figure 8 shows the embodiment of the elongated plate 60 with the expanding member 70 covering the distal portion of the device to protect the neural elements and terminating just prior to the distal end of the device 71 that enters the disc space.

**[0050]** Figure 9 illustrates an interbody implant 92 coupled to the insertion guide device 94. The interbody implant is in its collapsed configuration, and it may be any of the embodiments disclosed herein, or disclosed in US Patent Application No. 14/322,702 (Attorney Docket No. 44057-706.201) filed on July 2, 2014 and previously incorporated herein by reference. The insertion guide device may be any of the embodiments disclosed in this specification.

**[0051]** Figures 10A-10F illustrate an exemplary method of delivering an interbody implant using an insertion guide device such as those described in this specification. In Figure 10A, the insertion guide device 102 is inserted into the intervertebral disc space between adjacent vertebrae V. The elongated plates are in their collapsed configuration. The expandable member is advanced toward the vertebrae, but is not inserted into the intervertebral space.

**[0052]** In Figure 10B, the interbody implant 104 is advanced distally out of the insertion guide device 102 until it is exposed from the expandable portion of the insertion guide device and positioned in a desired location between the vertebrae, as illustrated in Figure 10C. Figure 10D is similar to Figure 10C but illustrates a longer portion of the insertion guide device. In Figure 10E, the interbody implant and the insertion guide device have been rotated preferably 90 degrees so that the textured surfaces of the interbody implant are in engagement with the endplates of the vertebrae. Figure 10F is a top view of the interbody implant and insertion guide device with the upper vertebra removed for ease in viewing. Additionally, the interbody implant has been laterally expanded to

increase its width. The interbody implant and the insertion guide device may be any of the embodiments disclosed herein. Additional details on the interbody implant are disclosed in US Patent Application No. 14/322,702 (Attorney Docket No. 44057-706.201) filed on July 2, 2014, and previously incorporated herein by reference.

**[0053]** Figures 11A-11B illustrate the pusher element which may be advanced or retracted by an operator to move the interbody implant through the insertion guide device disclosed above. In Figure 11A, the pusher element 1102 includes an elongate shaft with a handle on the proximal end for ease in manipulation. A lever 1104 helps lock the pusher to the interbody implant. Figure 11B illustrates the interbody implant 1106 coupled to the pusher element 1102. A leaf spring is disposed under the actuation lever thereby biasing the lever in the up position so that the pusher remains locked with the interbody implant. When the lever is moved, the implant may be decoupled from the pusher. The pusher/implant assembly is preferably inserted into the elongated plate assembly for delivery to the intervertebral space.

**[0054]** Figures 12A-12B illustrate another exemplary embodiment of elongated plates that may be used in an insertion guide device. Figure 12A shows an exemplary embodiment of an elongated plate 80 with rails 81 that extend outward from the plate and guide the implant into the disc space. Pre-formed finger loops 82 on the proximal end of the plate allow a user to more easily control the insertion guide device position. Rails 81 end prior to the distal portion 83 of the elongated plate and extend up to the transition 84 to finger loop 82. Figure 12B illustrates a side view of Figure 12A.

**[0055]** Figures 13A-13B illustrate an insertion guide device using the elongated plates of Figure 12A. In Figure 13A, the insertion guide device is illustrated in the collapsed configuration. Two of the elongated plates 80 are shown joined by an expandable member 90 which may be any of the embodiments of expandable member disclosed herein. Expandable member 90 is preferably attached to the top surfaces 91 of elongated plates 80 via an adhesive. Expandable member 90 also has a bead 92 to help resist tearing of the expandable member during use. The bead may be a rolled up section of the expandable member to increase thickness and resistance to tearing, or it may be a separate material coupled to the expandable member to provide the reinforcement.

**[0056]** Figure 13B illustrates the embodiment of Figure 13A in the expanded configuration.

**[0057]** Figure 14 illustrate the insertion guide device of Figure 13A inserted into the intervertebral disc space. The insertion guide device is positioned such that the distal portions 83 of the elongated plates 80 engage the endplates of the adjacent vertebral bodies 95 and 96. The expandable member 90 remains outside of the intervertebral space.

**[0058]** Figures 15A-15B illustrate still another exemplary embodiment of elongated plates that may be used in an insertion guide device. Figure 15A shows an elongated plate 100 with stop feature 101 to prevent the insertion guide device from being inserted too far anteriorly into the disc space. The stop 101 is preferably a protrusion which extends out of the plane of the elongated plate. Other



aspects of the elongated plate are generally the same as the embodiment illustrated in Figure 12A-12B. Figure 15B is a side view of Figure 15A.

**[0059]** Figure 16A illustrates an exemplary embodiment of an insertion guide device using one elongated plate as illustrated in Figure 15A with a stop, and another elongated plate as illustrated in Figure 12A without a stop. The embodiment in Figure 15A is in the collapsed configuration. Expandable member 90 joins elongated plates 80 and 90 together. Other aspects of the insertion guide device are generally the same as previously described above. An alternative embodiment of the insertion guide device may have two elongated plates both having stops. Thus, the insertion guide may have two elongated plates such as those described in Figure 15A. Other aspects of this alternative embodiment may be the same as those previously described. Figure 16B illustrates the insertion guide device in Figure 16A in the expanded (also referred to as distracted) configuration.

**[0060]** Figure 17 shows the insertion guide device of Figure 16A inserted into the intervertebral disc space. Stop feature 101 engages the edge of superior vertebral body 110 to prevent the insertion guide device from moving further anterior. In alternative embodiments, the stop feature may engage the edge of the inferior vertebral body 96, or in embodiments with two stops, an edge of the inferior and superior vertebral body may be engaged by a stop feature.

**[0061]** While preferred embodiments of the present invention have been shown and described herein, it will be obvious to those skilled in the art that such embodiments are provided by way of example only. Numerous variations, changes, and substitutions will now occur to those skilled in the art without departing from the invention. It should be understood that various alternatives to the embodiments of the invention described herein may be employed in practicing the invention. It is intended that the following claims define the scope of the invention and that methods and structures within the scope of these claims and their equivalents be covered thereby.

## WHAT IS CLAIMED IS:

1. A delivery instrument for facilitating placement of an interbody implant into an intervertebral space of a patient, said delivery instrument comprising:
  - a plurality of elongated plates disposed adjacent one another, each elongated plate having a proximal portion and a distal portion, wherein the distal portion of the elongated plates is sized and shaped to fit into the intervertebral space, and wherein the distal portion of the elongated plates is configured to engage a vertebral body in the intervertebral space; and
  - an expandable member coupled to the plurality of elongated plates so as to form an enclosed tube for at least a portion of a length of the plurality of elongated plates, wherein the enclosed tube is sized and shaped to receive the interbody implant, and
  - wherein the expandable member allows for translation of the plurality of elongated plates relative to one another as the interbody implant passes through the tube.
2. The delivery instrument of claim 1, wherein the expandable member is an elastomeric tube that is disposed over the plurality of elongated plates.
3. The delivery instrument of claim 1, wherein the expandable member comprises two or more flexible sheets of resilient material that extend from one elongated plate to another elongated plate.
4. The delivery instrument of claim 1, wherein the plurality of elongated plates have a geometry configured to engage the interbody implant passing through the tube, and wherein the plurality of elongated plates have a geometry that guides the interbody implant into the intervertebral space.
5. The delivery instrument of claim 4, wherein the geometry that engages the interbody implant comprises a plurality of rails extending from the plurality of elongated plates.
6. The delivery instrument of claim 1, wherein the plurality of plates are expandable to allow the delivery instrument to expand in multiple directions in order to accommodate various sizes of interbody implants.
7. The delivery instrument of claim 6, wherein the plurality of plates have a longitudinally oriented slit located therealong, the slit configured to allow the plurality of plates to expand and contract.
8. The delivery instrument of claim 7, wherein longitudinally oriented slit comprises a stress relief feature.

9. The delivery instrument of claim 1, wherein the plurality of plates are coupled together adjacent their proximal portion.
10. The delivery instrument of claim 1, wherein at least one of the plurality of elongated plates comprises a finger loop adjacent a proximal end thereof, the finger loop configured to facilitate grasping by an operator's finger.
11. The delivery instrument of claim 1, further comprising a stop element disposed adjacent a distal portion of at least one of the plurality of elongated plates, the stop element configured to limit insertion of the delivery instrument into the intervertebral space.
12. A system for delivering an implant to an intervertebral space of a patient, said system comprising:  
the delivery instrument of claim 1; and  
an interbody implant.
13. A method for delivering an interbody implant into an intervertebral space between adjacent vertebral bodies of a patient, said method comprising:  
providing a delivery instrument having a plurality of elongated plates disposed adjacent one another and coupled together with an expandable member thereby forming a tube;  
advancing the interbody implant along the tube formed by the plurality of elongated plates and the expandable member;  
translating the plurality of elongated plates relative to one another as the interbody implant advances along the tube;  
ejecting the interbody implant from the delivery device; and  
returning the elongated plates to an unbiased configuration after the interbody implant has been ejected.
14. The method of claim 13, wherein translating the plurality of elongated plates comprises moving the plurality of plates away from one another.
15. The method of claim 13, wherein translating the plurality of elongated plates comprises expanding or collapsing the expandable member.
16. The method of claim 15, wherein the expandable member comprises an elastomeric tube that is disposed over the plurality of elongated plates.
17. The method of claim 13, wherein advancing the interbody implant comprises guiding the interbody implant along the tube with a plurality of rails extending from the plurality of elongated plates.

18. The method of claim 13, further comprising a stress relief feature in one or more of the plurality of elongated plates, the method further comprising relieving stress in the delivery instrument as the interbody implant is translated therealong.

19. The method of claim 13, wherein translating the plurality of elongated plates comprises expanding or contracting a slit disposed in at least one of the plurality of elongated plates.

20. The method of claim 13, wherein the plurality of elongated plates are coupled to one another adjacent a proximal portion thereof, and wherein translating the plurality of elongated plates comprises pivoting the plurality of elongated plates relative to the proximal portion.

21. The method of claim 13, wherein ejecting comprises disposing the interbody implant in the intervertebral space.

22. The method of claim 13, further comprising engaging a distal portion of the plurality of elongated plates with the vertebral bodies.

23. The method of claim 13, further comprising grasping the delivery device by inserting one or more fingers in a finger loop disposed on a proximal portion of at least one of the plurality of elongated plates.

24. The method of claim 13, further comprising:  
advancing the plurality of elongate plates into the intervertebral space; and  
limiting penetration of the plurality of elongate plates into the intervertebral space by engaging a stop element disposed on at least one of the plurality of elongate plates against an edge of at least one of the adjacent vertebral bodies.

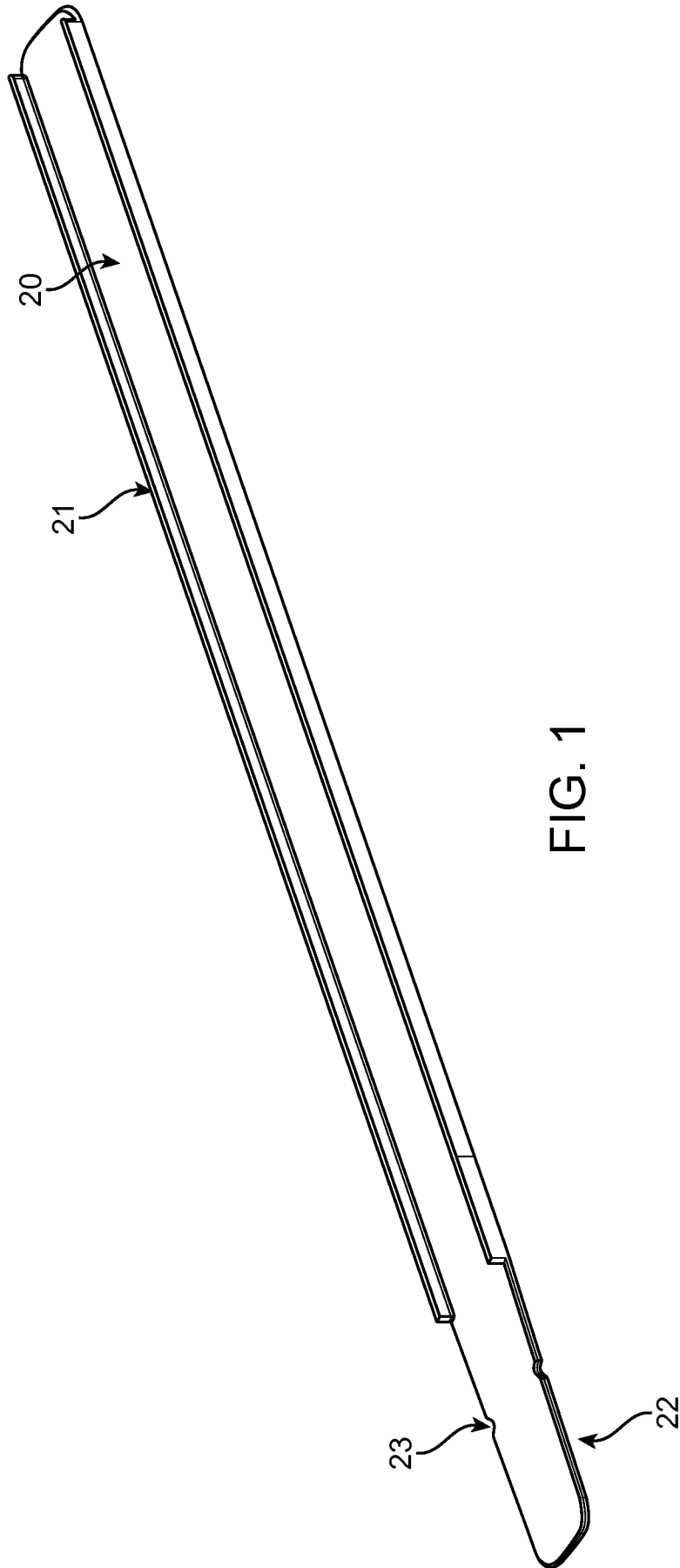

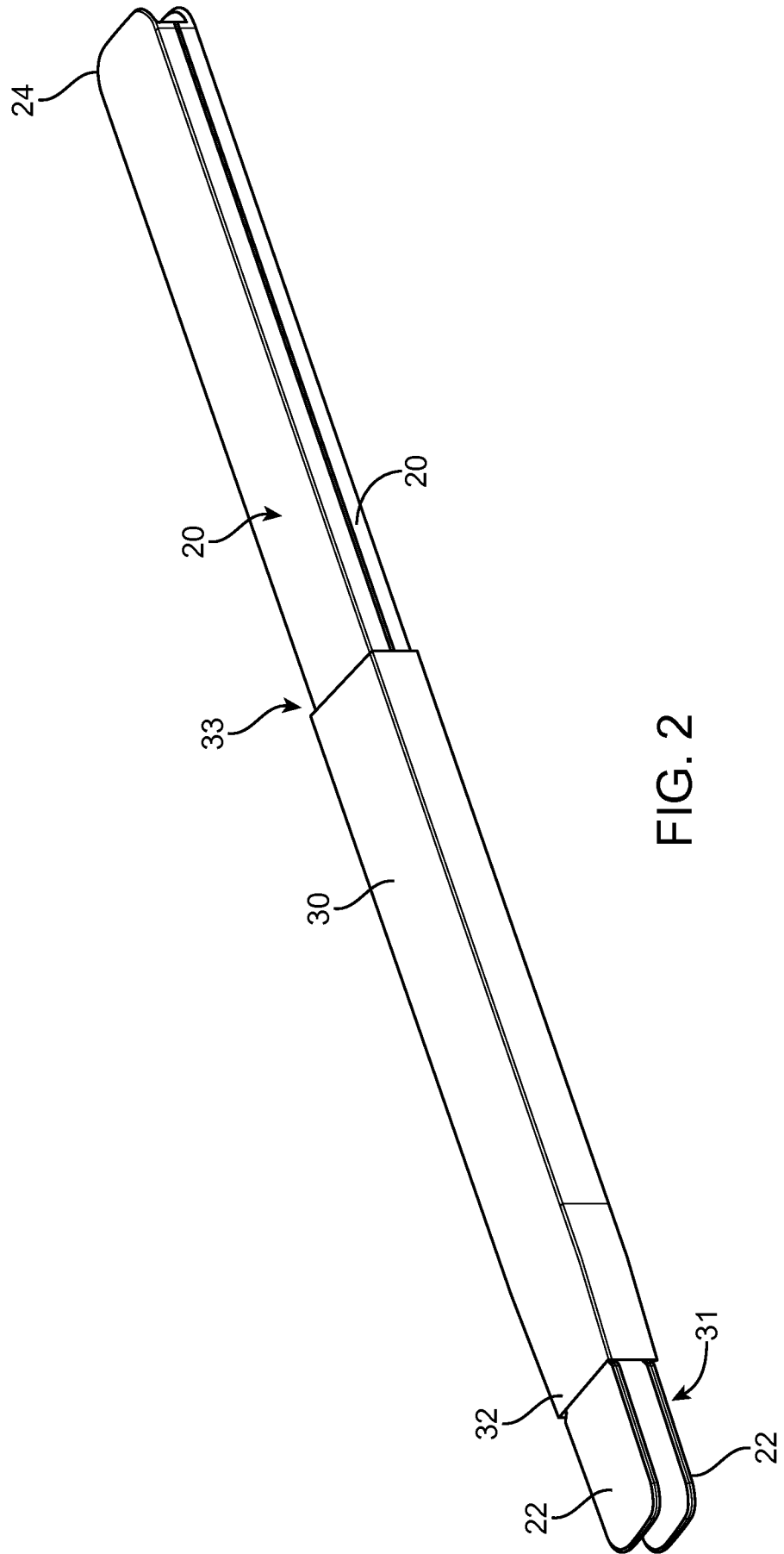

FIG. 2

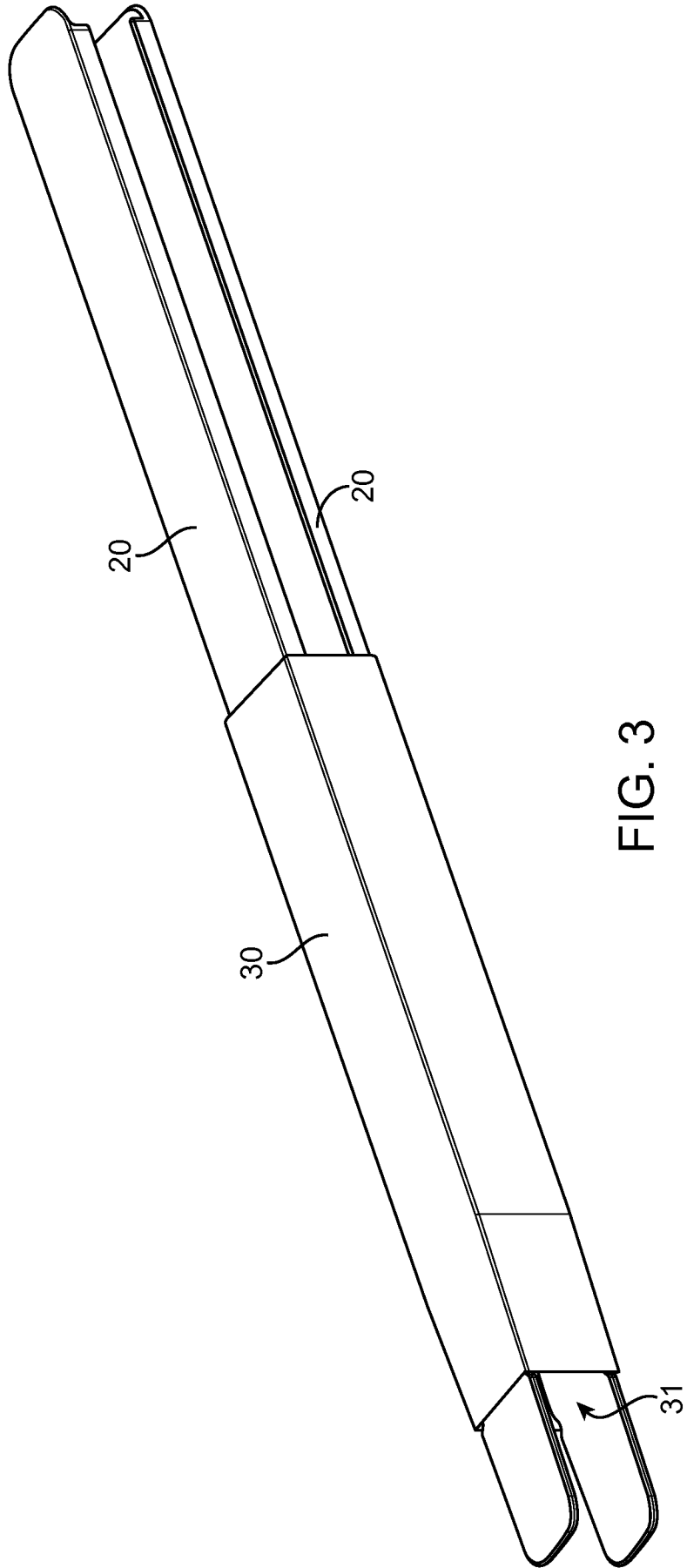

FIG. 3

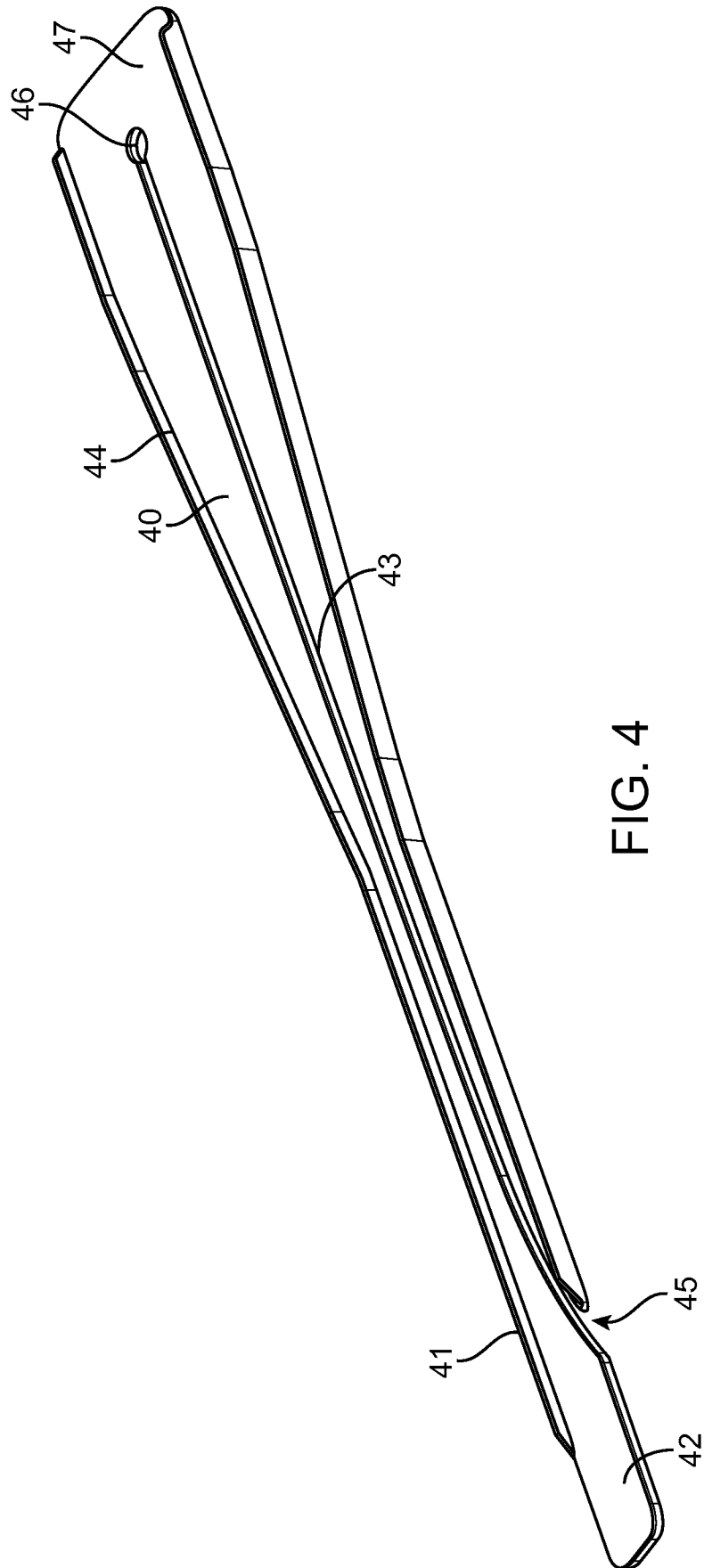

FIG. 4



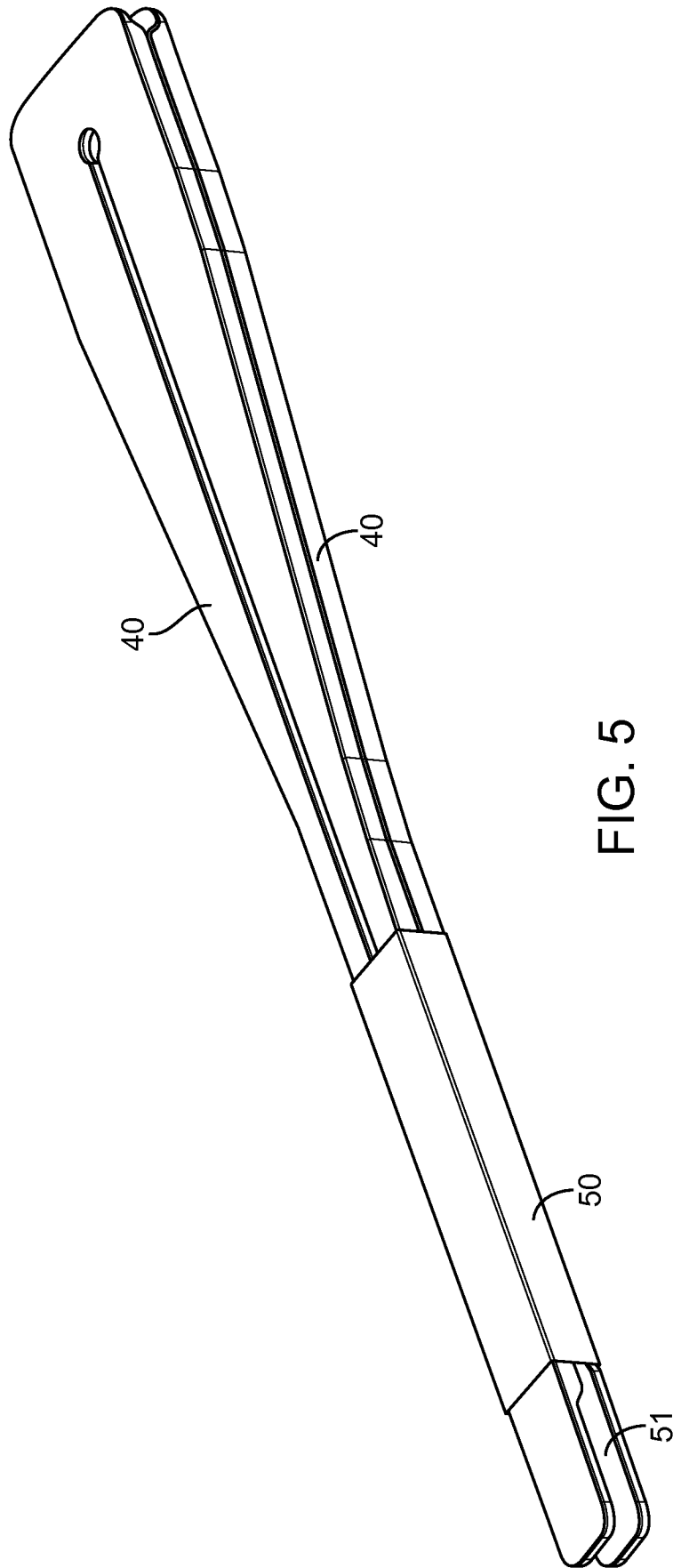
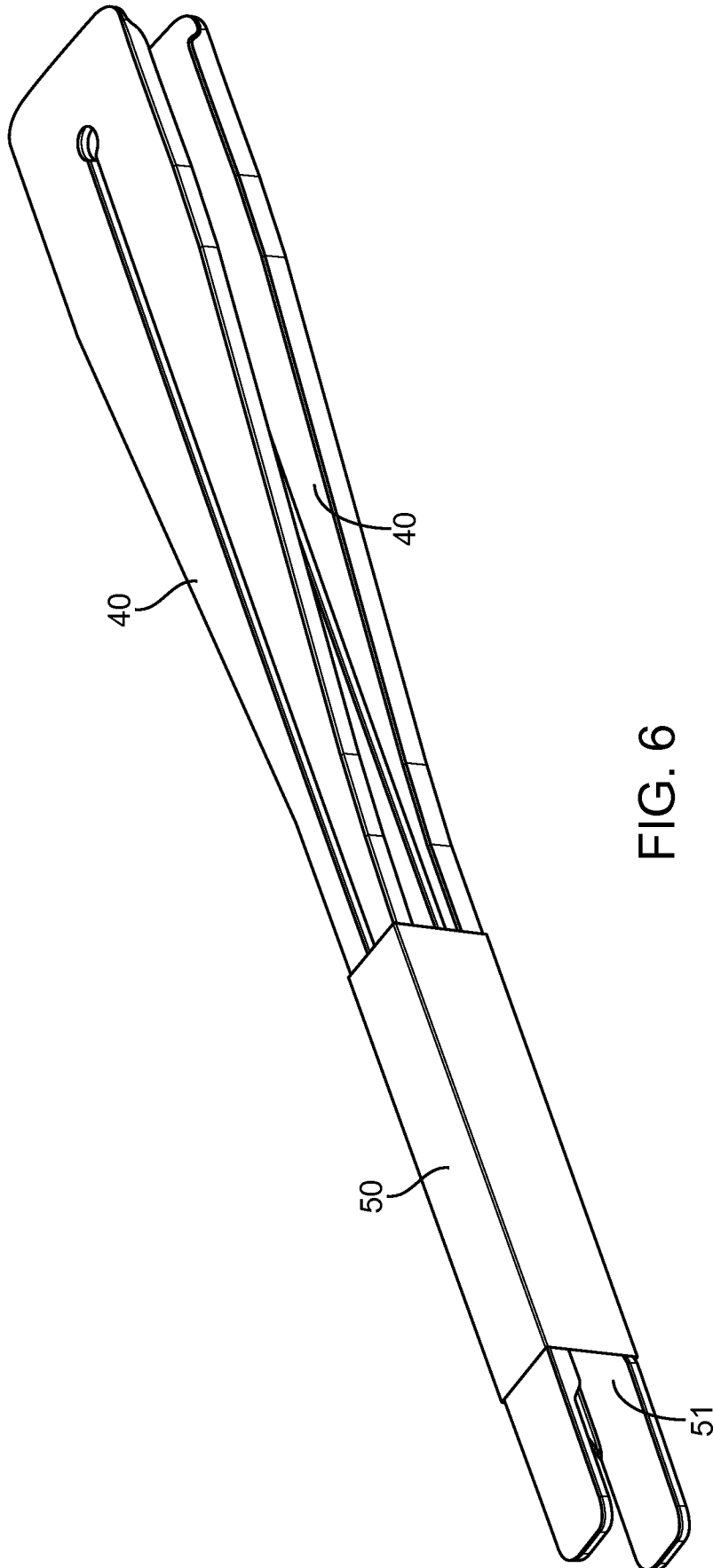

FIG. 5



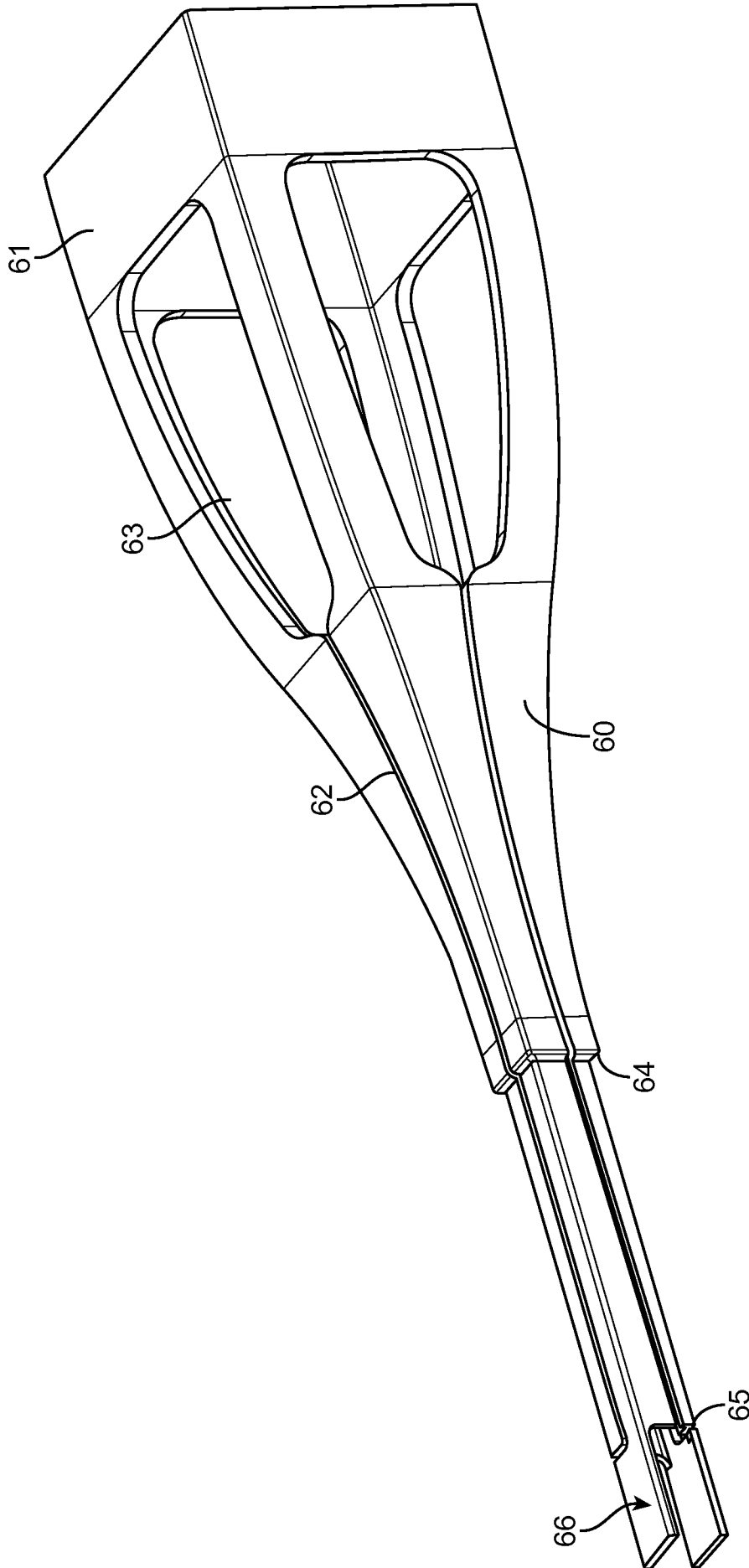

FIG. 7

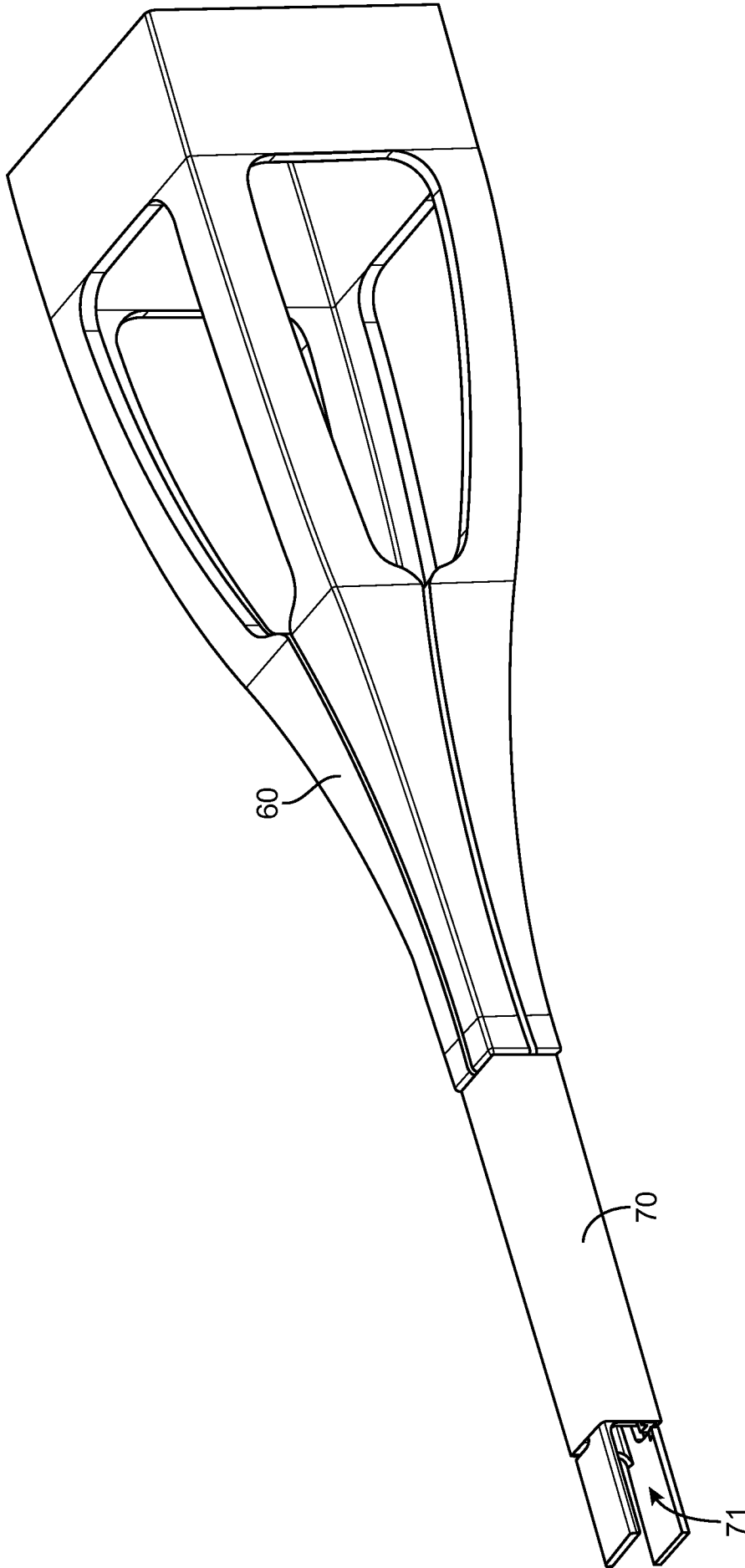

FIG. 8

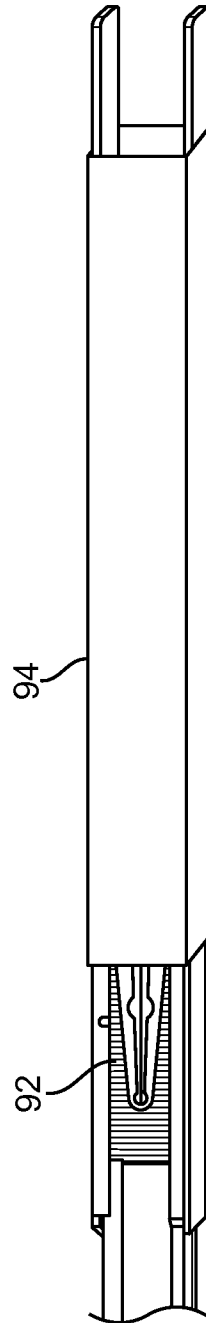

FIG. 9

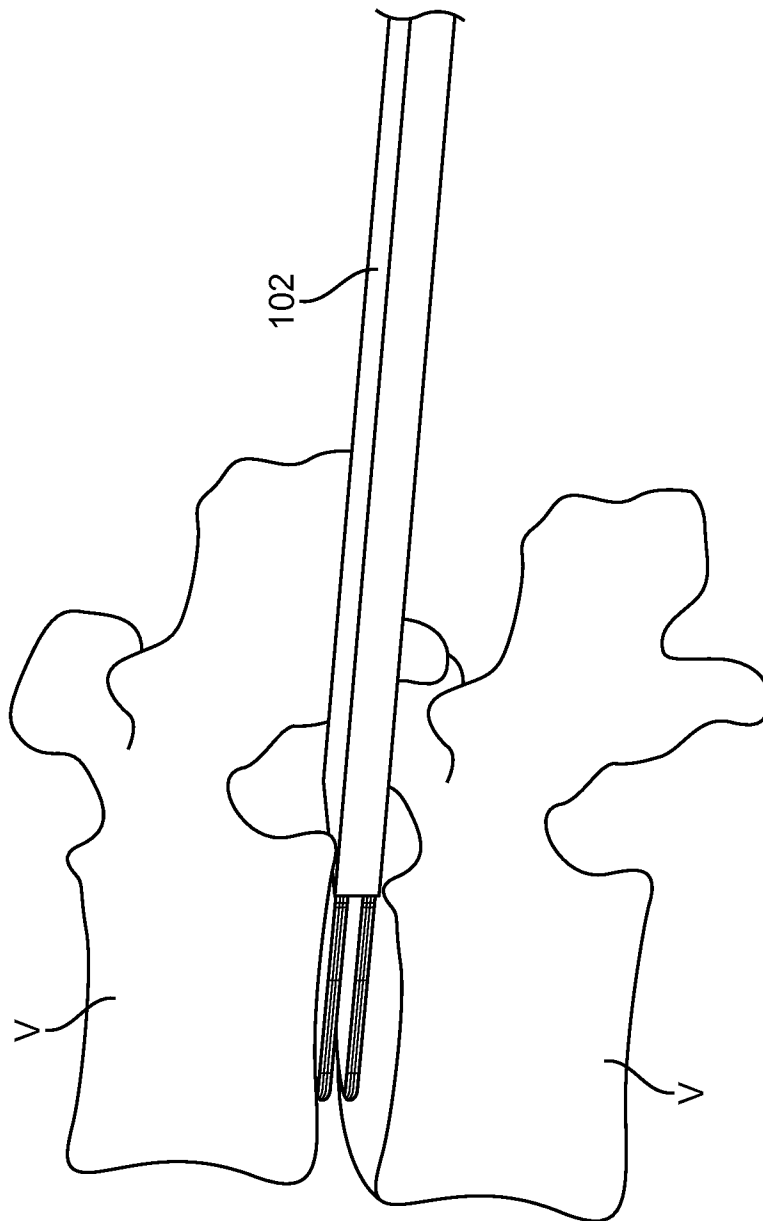

FIG. 10A

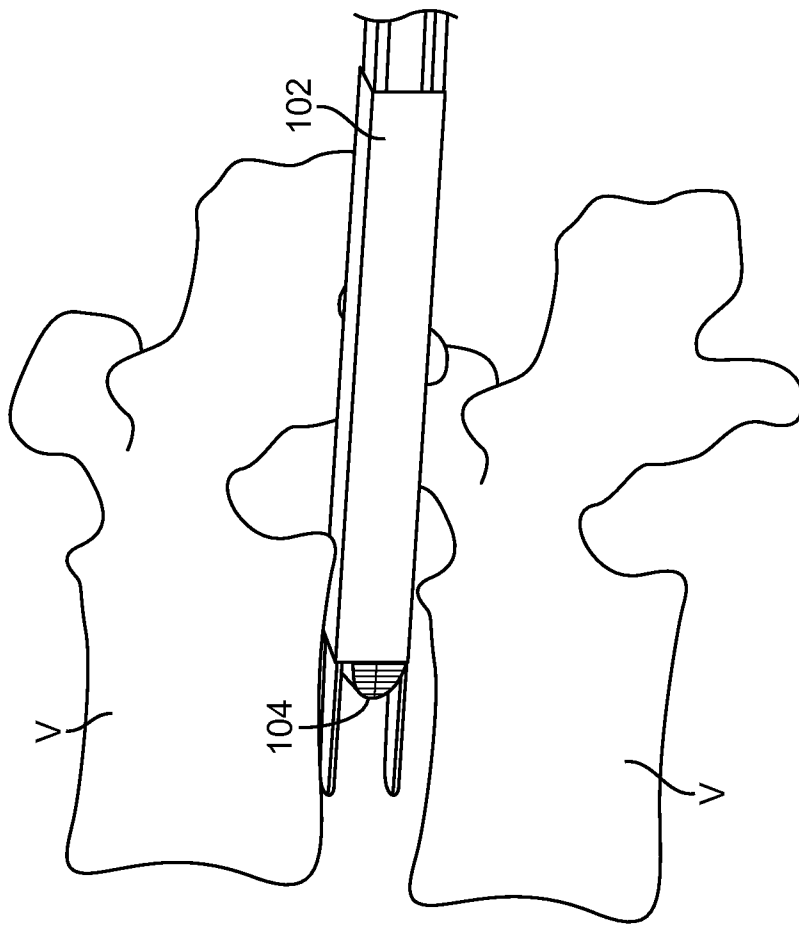

FIG. 10B

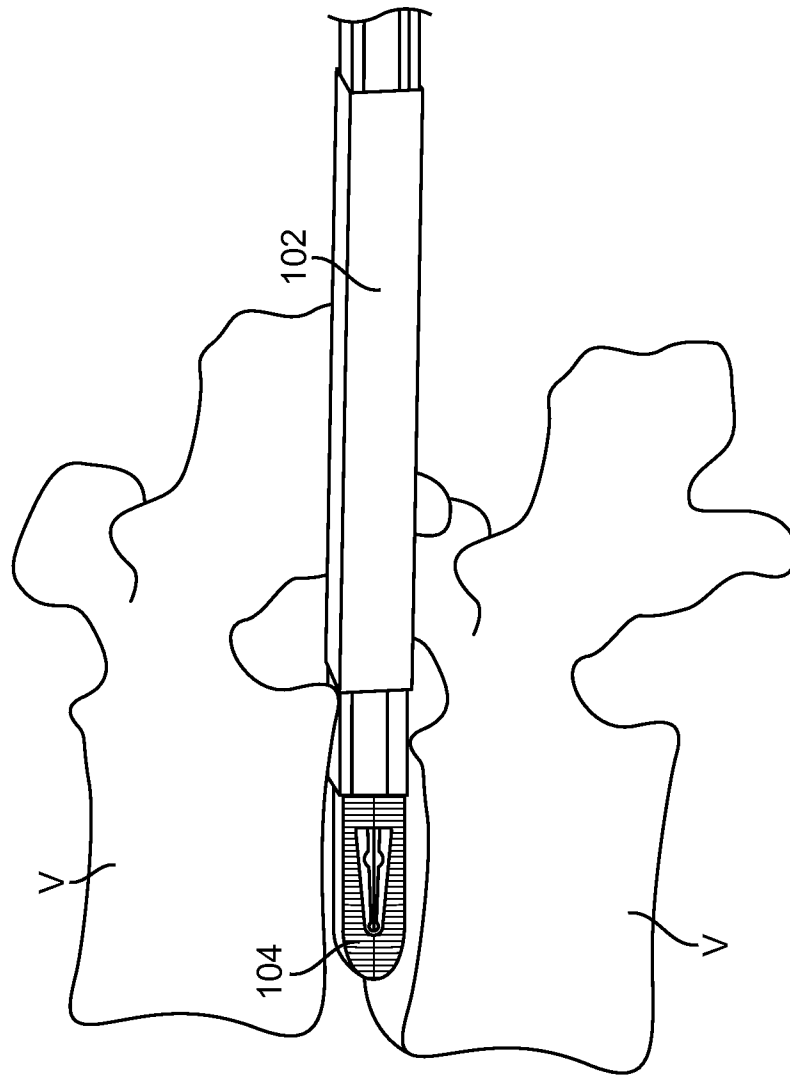

FIG. 10C



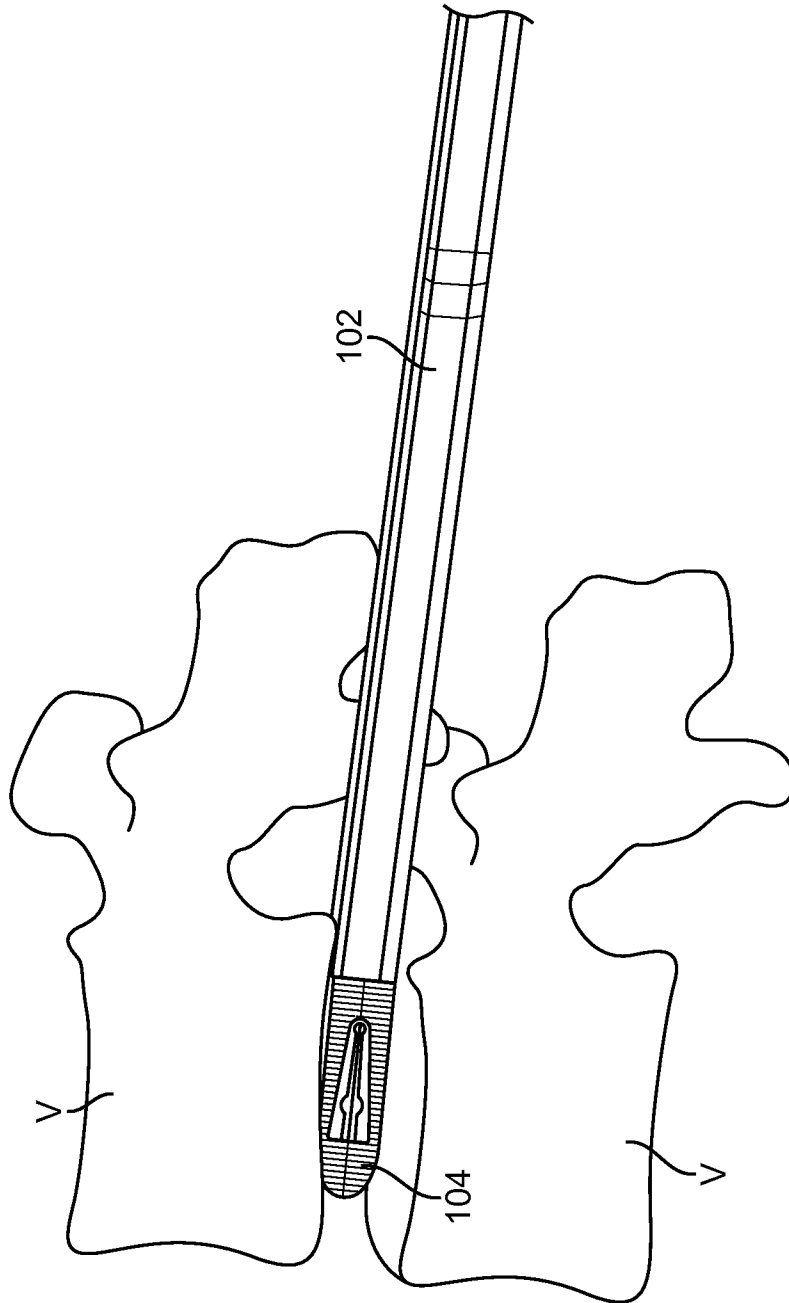

FIG. 10D

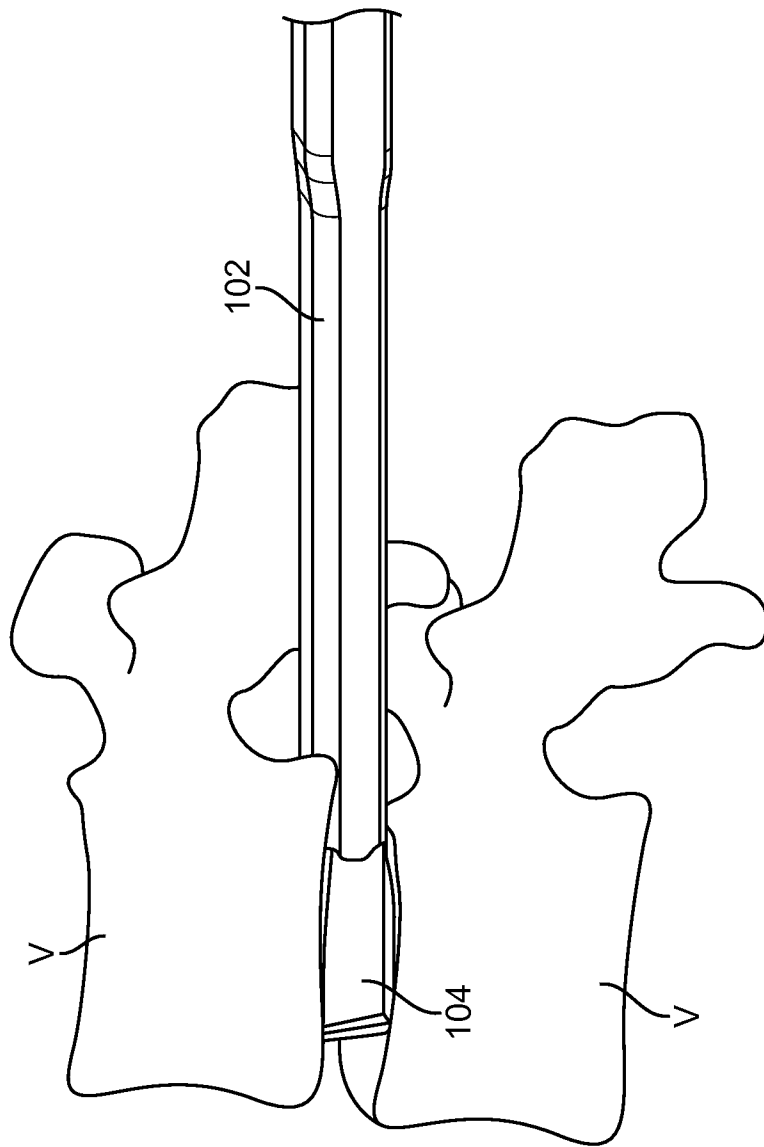

FIG. 10E

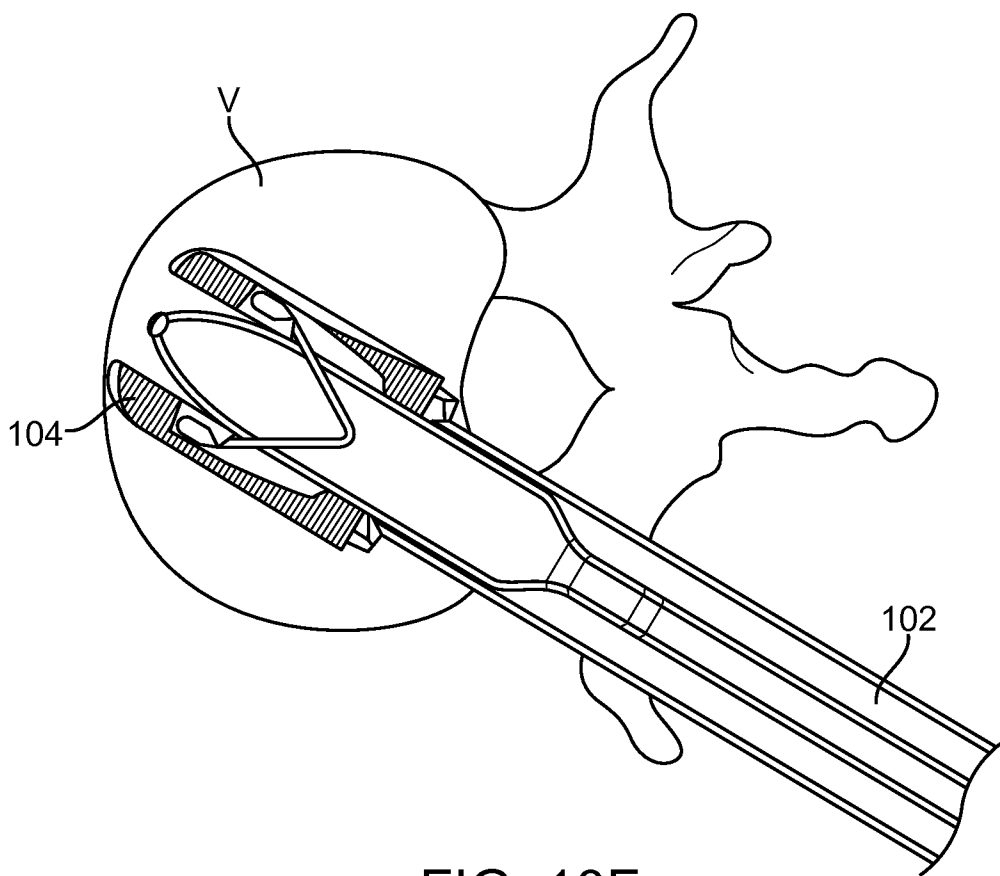

FIG. 10F

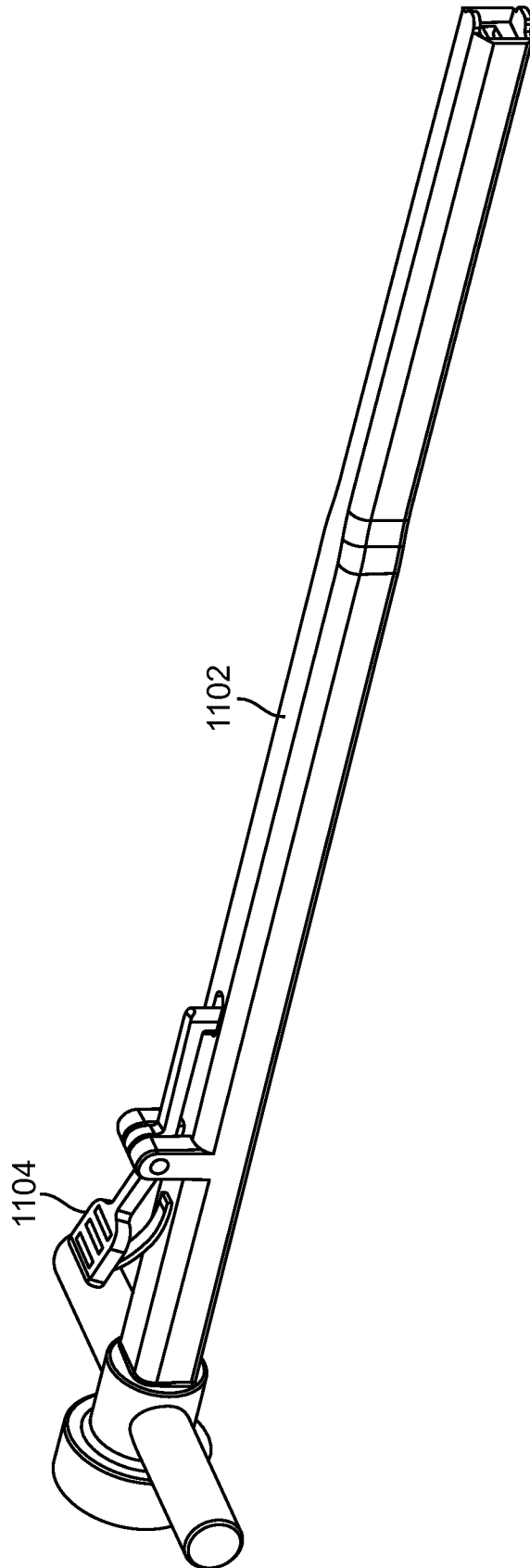

FIG. 11A

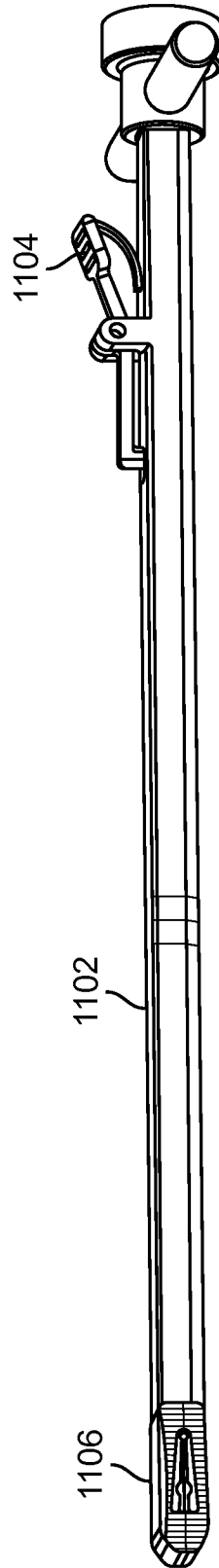

FIG. 11B

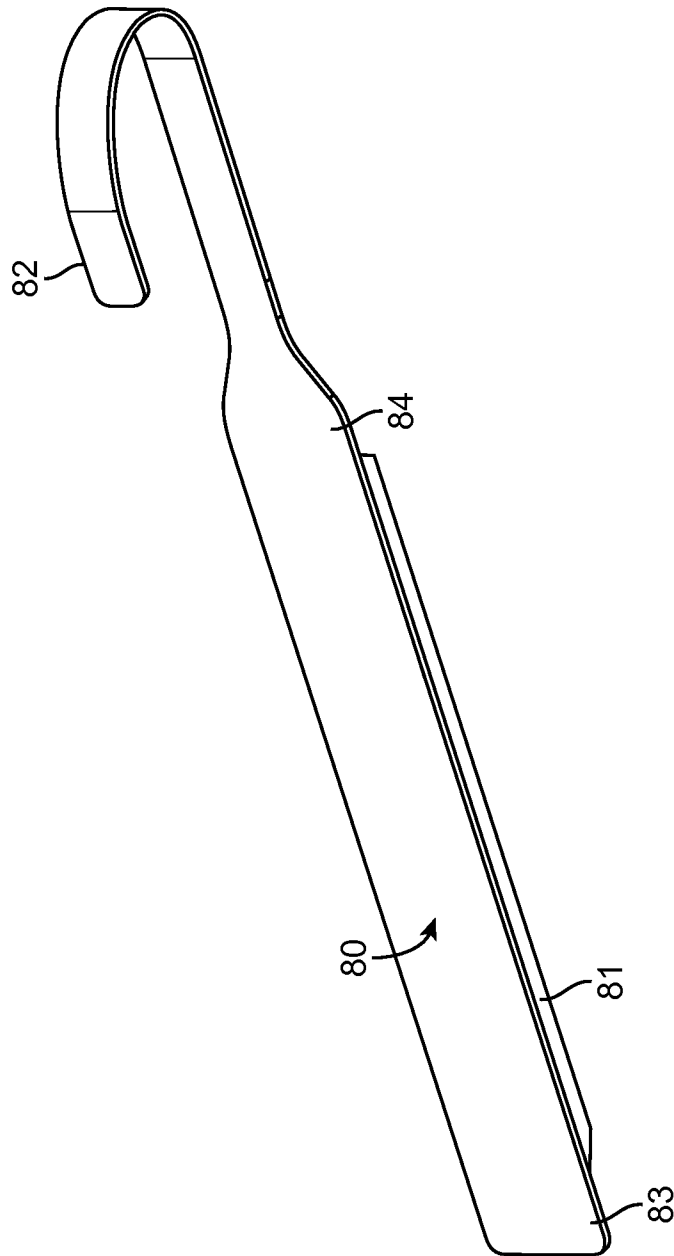

FIG. 12A

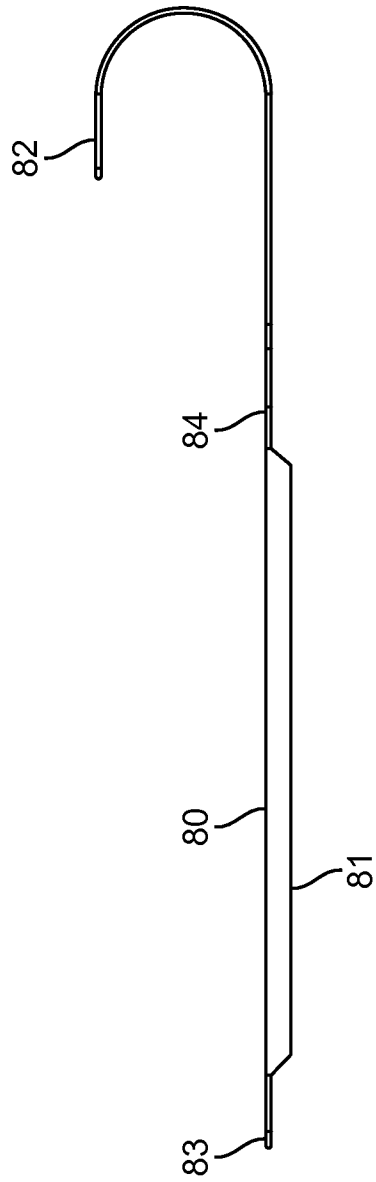

FIG. 12B

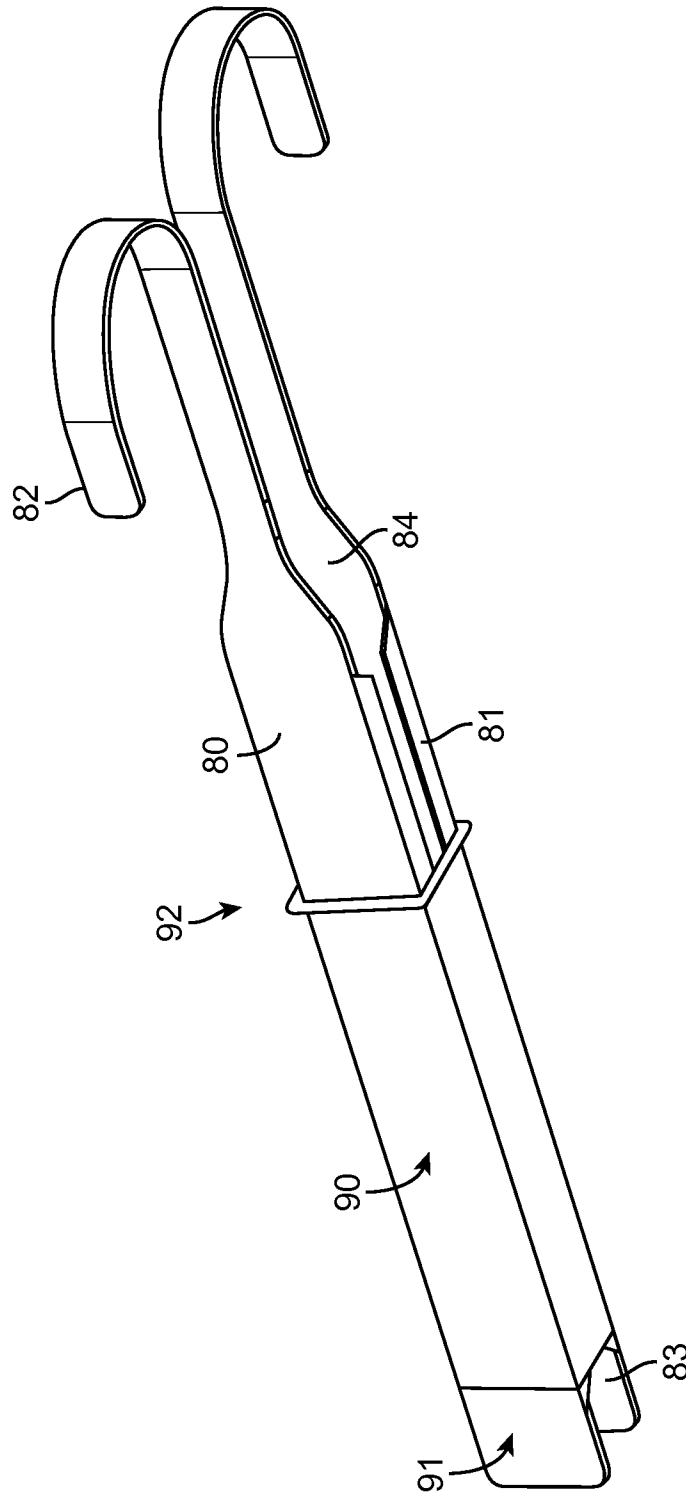

FIG. 13A



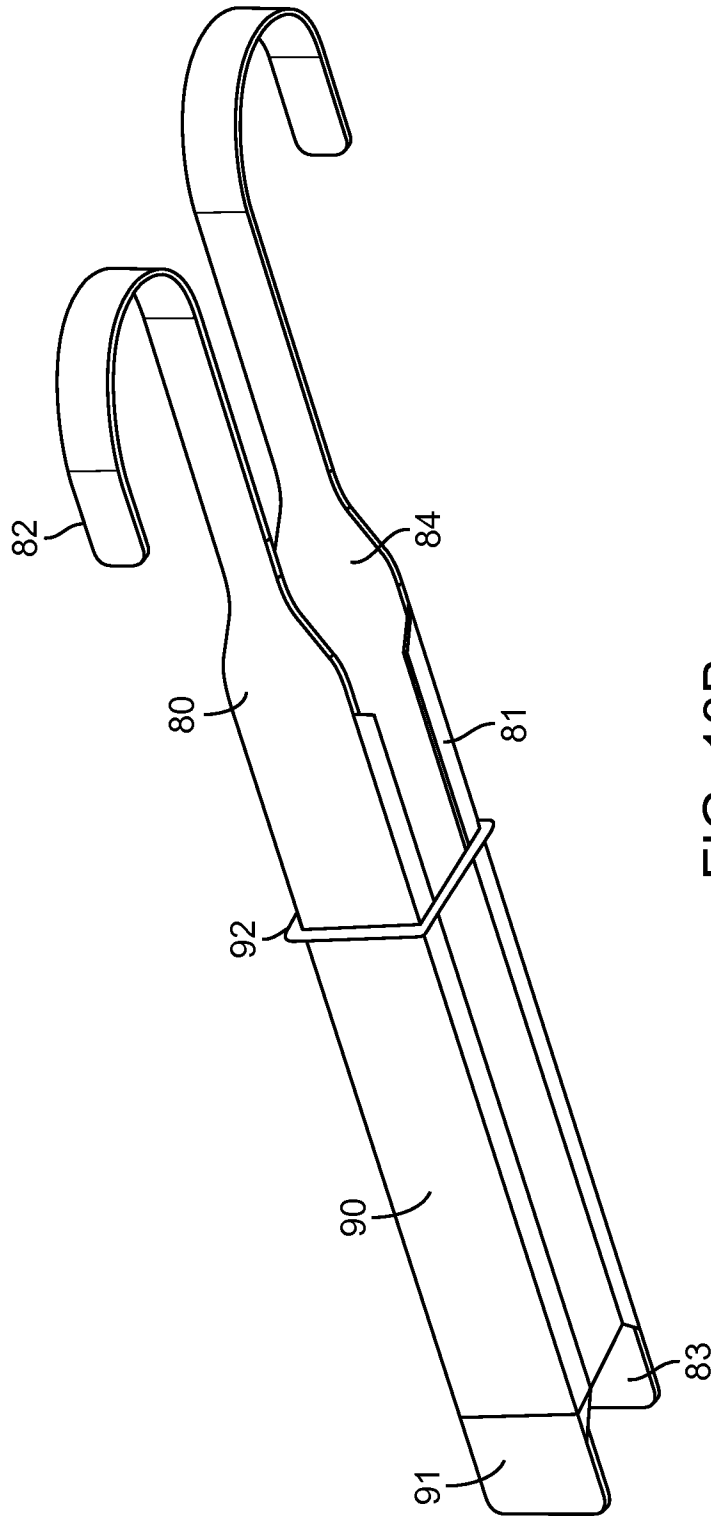

FIG. 13B

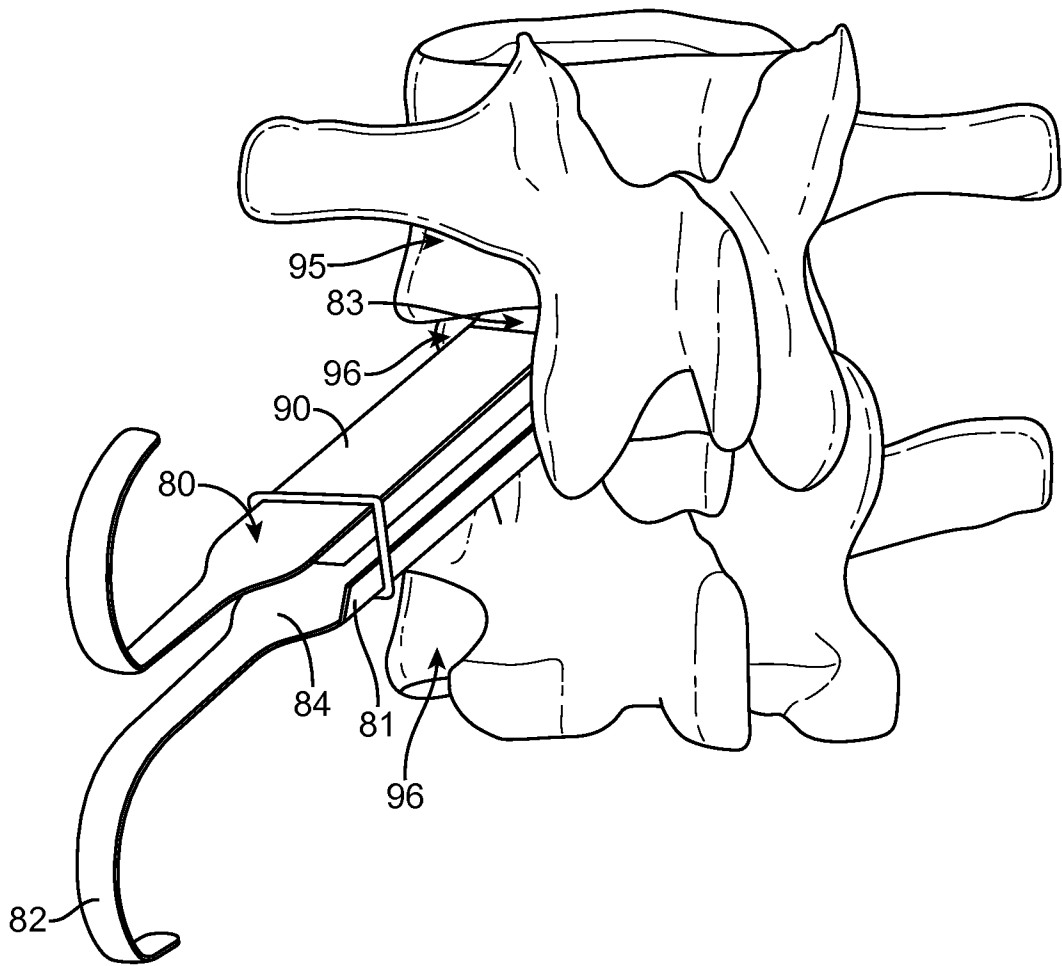

FIG. 14

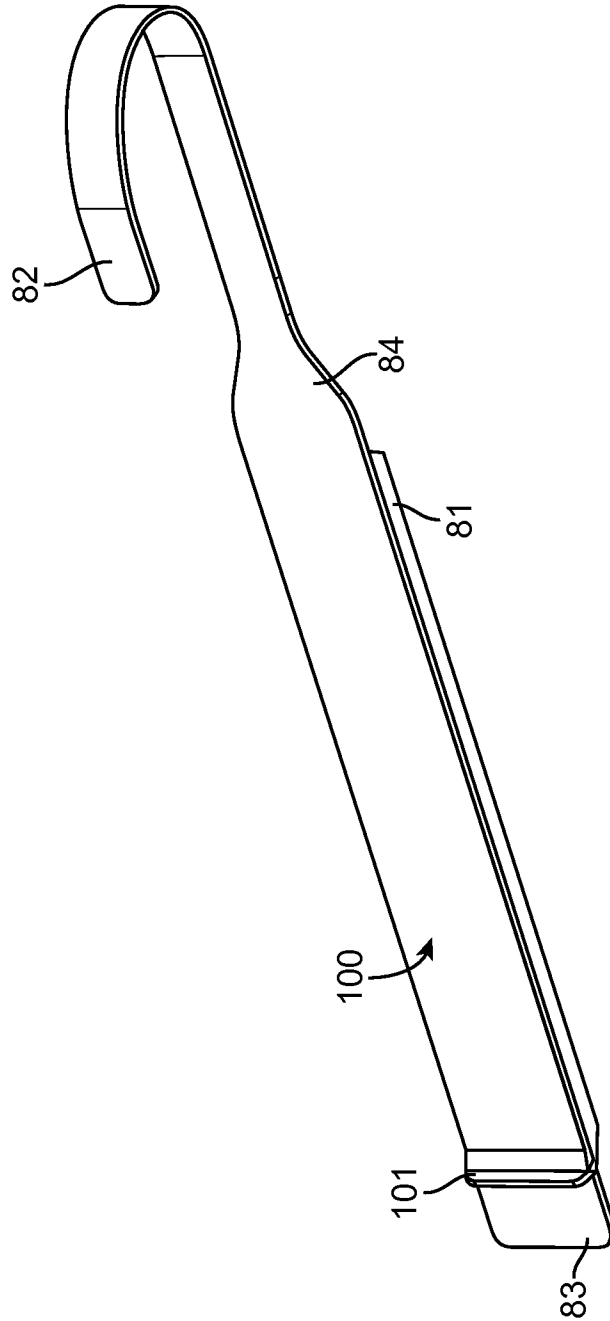

FIG. 15A

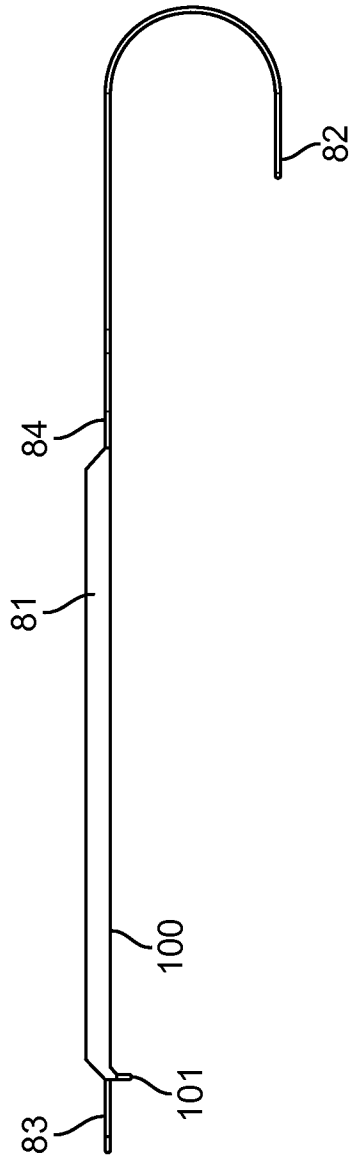

FIG. 15B

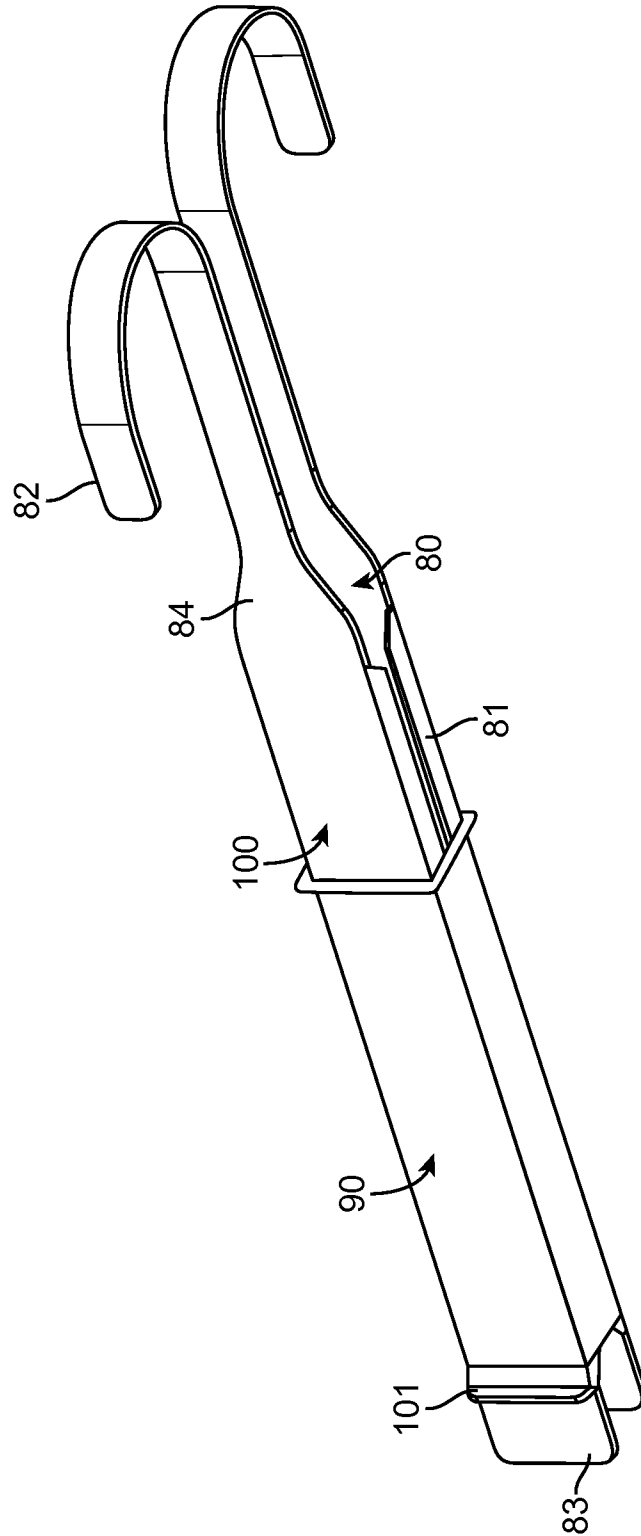

FIG. 16A

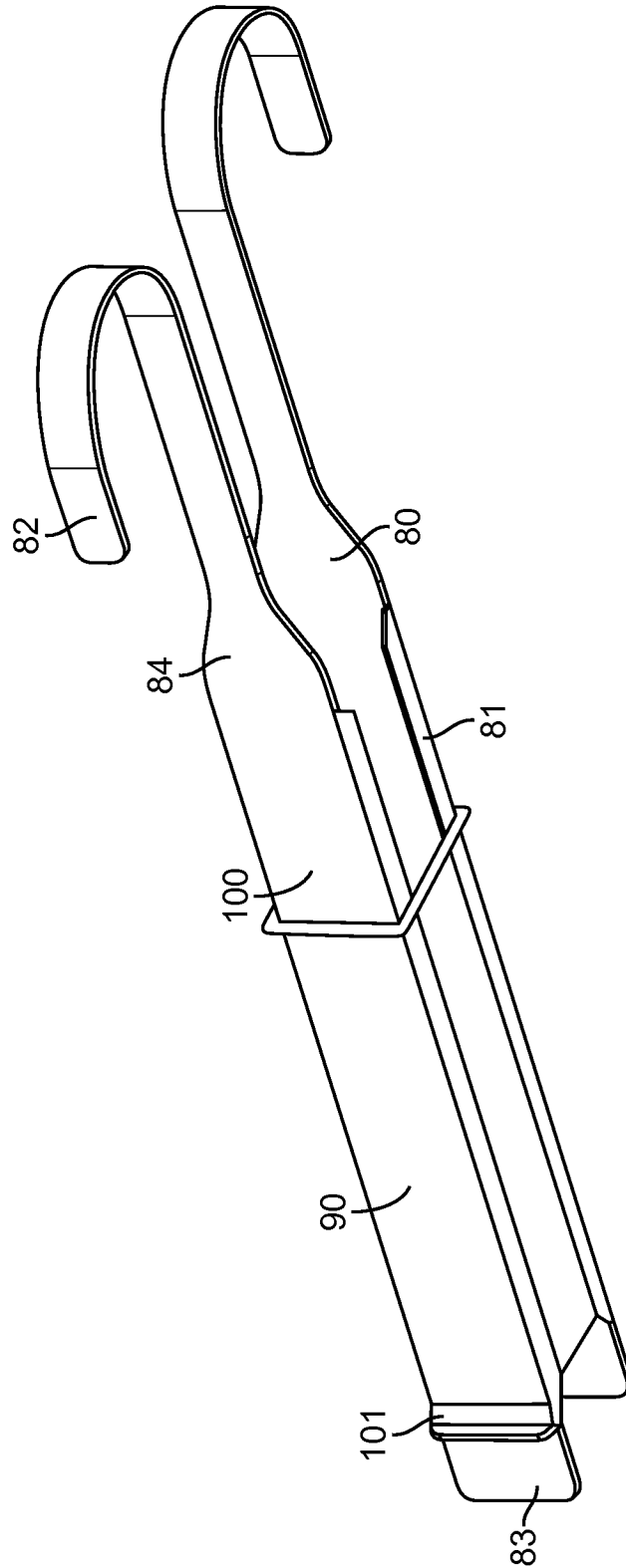

FIG. 16B

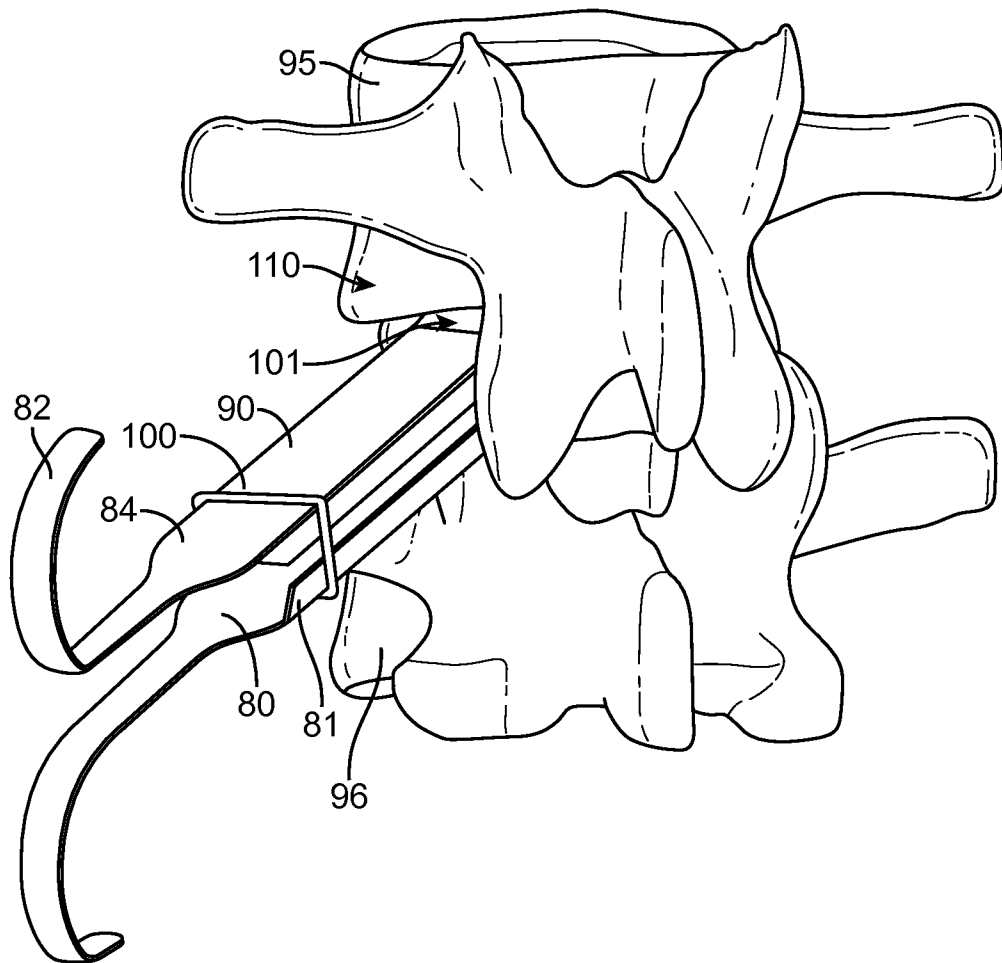

FIG. 17

**INTERNATIONAL SEARCH REPORT**

International application No.

PCT/US2014/045489

**A. CLASSIFICATION OF SUBJECT MATTER**

IPC(8) - A61 17/00 (2014.01)

CPC - A61 2017/0256 (2014.10)

According to International Patent Classification (IPC) or to both national classification and IPC

**B. FIELDS SEARCHED**

Minimum documentation searched (classification system followed by classification symbols)

IPC(8) - A61B 17/00, 17/56, 17/58, 17/70, 17/88, 17/92; A61F 2/00, 2/02, 2/30, 2/44, 2/46 (2014.01)

CPC - A61B 17/025, 2017/0256, 2017/02662, 17/56, 17/58, 17/70, 17/88, 17/92; A61F 2/00, 2/02, 2/30, 2/44, 2/442, 2/4425 (2014.10)

Documentation searched other than minimum documentation to the extent that such documents are included in the fields searched

CPC (con't)- A61F 2/4455, 2/46, 2/4603, 2/4611 (2014.10)

USPC - 606/53, 86, 99; 623/17.16

Electronic data base consulted during the international search (name of data base and, where practicable, search terms used)

Orbit, Google Patents, Google Scholar.

**C. DOCUMENTS CONSIDERED TO BE RELEVANT**

Category*	Citation of document, with indication, where appropriate, of the relevant passages	Relevant to claim No.
X	US 8,343,163 B1 (ARAMBULA et al) 01 January 2013 (01.01.2013) entire document	1, 3-9, 11-14, 17-22, 24
Y		2, 10, 15-16, 23
Y	US 2012/0016196 A1 (KAMBIN et al) 19 January 2012 (19.01.2012) entire document	2, 10, 15-16, 23
A	US 8,439,924 B1 (MCBRIDE et al) 14 May 2013 (14.05.2013) entire document	1-24

Further documents are listed in the continuation of Box C.

\* Special categories of cited documents:

"A" document defining the general state of the art which is not considered to be of particular relevance

"E" earlier application or patent but published on or after the international filing date

"L" document which may throw doubts on priority claim(s) or which is cited to establish the publication date of another citation or other special reason (as specified)

"O" document referring to an oral disclosure, use, exhibition or other means

"P" document published prior to the international filing date but later than the priority date claimed

"T" later document published after the international filing date or priority date and not in conflict with the application but cited to understand the principle or theory underlying the invention

"X" document of particular relevance; the claimed invention cannot be considered novel or cannot be considered to involve an inventive step when the document is taken alone

"Y" document of particular relevance; the claimed invention cannot be considered to involve an inventive step when the document is combined with one or more other such documents, such combination being obvious to a person skilled in the art

"&" document member of the same patent family

Date of the actual completion of the international search

17 October 2014

Date of mailing of the international search report

**04 NOV 2014**

Name and mailing address of the ISA/US

Mail Stop PCT, Attn: ISA/US, Commissioner for Patents  
P.O. Box 1450, Alexandria, Virginia 22313-1450

Facsimile No. 571-273-3201

Authorized officer:

Blaine R. Copenheaver

PCT Helpdesk: 571-272-4300  
PCT OSP: 571-272-7774