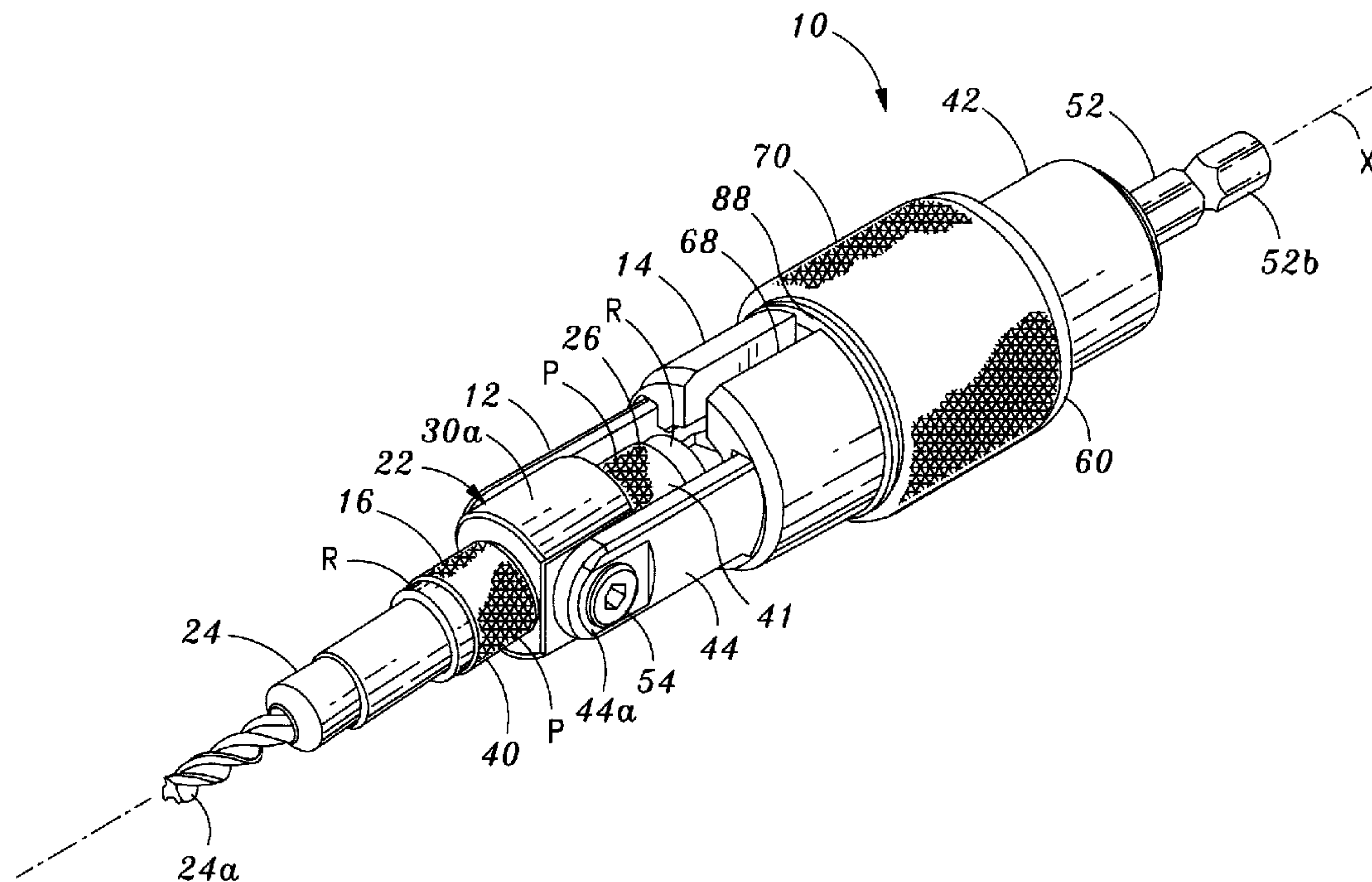




(22) **Date de dépôt/Filing Date:** 2004/08/04  
(41) **Mise à la disp. pub./Open to Public Insp.:** 2005/02/08  
(30) **Priorité/Priority:** 2003/08/08 (60/493,506) US

(51) **Cl.Int.<sup>7</sup>/Int.Cl.<sup>7</sup>** B23B 45/00  
(71) **Demandeur/Applicant:**  
ALLTRADE TOOLS, LLC, US  
(72) **Inventeurs/Inventors:**  
HERNANDEZ, HECTOR RAY, JR., US;  
NASH, JAIME, US  
(74) **Agent:** OYEN WIGGS GREEN & MUTALA

(54) **Titre : PERCEUSE-TOURNEVIS REVERSIBLE**  
(54) **Title: REVERSIBLE DRILL AND DRIVE TOOL**



(57) **Abrégé/Abstract:**

A tool adapted to be coupled to a power drill includes a multi-component bit mounted to reverse positions so that in one position its drill element drills a hole and in another position its driver element drives in a fastener.

1  
2

ABSTRACT OF DISCLOSURE

A tool adapted to be coupled to a power drill includes a multi-component bit mounted to reverse positions so that in one position its drill element drills a hole and in another position its driver element drives in a fastener.

# REVERSIBLE DRILL AND DRIVE TOOL

## RELATED PATENT APPLICATIONS & INCORPORATION BY REFERENCE

This application is a utility application based on U. S. provisional patent application Serial No. 60/493,506, entitled "REVERSIBLE DRILL AND DRIVE TOOL," filed August 8, 2003. This related application is incorporated herein by reference and made a part of this application. If any conflict arises between the disclosure of the invention in this utility application and that in the related provisional application, the disclosure in this utility application shall govern. Moreover, the inventors incorporate herein by reference any and all U. S. patents, U. S. patent applications, and other documents cited or referred to in this application.

## DEFINITIONS

The words "comprising," "having," "containing," and "including," and other forms thereof, are intended to be equivalent in meaning and be open ended in that an item or items following any one of these words is not meant to be an exhaustive listing of such item or items, or meant to be limited to only the listed item or items.

## BACKGROUND OF INVENTION

In the construction and renovation of commercial and residential buildings as well as in various manufacturing operations, it is often necessary to perform repeated drilling and driving operations. For example, a hole is drilled into a wall or ceiling surface and then a screw or similar fastener is driven into the drilled hole. U. S. Patent Nos. 4,512,693 and 4,676,703 are illustrative of tools that can be attached to a power drill to allow this drill to both drill a hole and drive in a screw or other type of fastener.

## SUMMARY OF INVENTION

This invention has one or more features as discussed subsequently herein. After reading the following section entitled "DETAILED DESCRIPTION OF SOME

1 EMBODIMENTS OF THIS INVENTION,” one will understand how the features of this  
2 invention provide its benefits. The benefits of this invention include, but are not limited to:  
3 sturdy construction, ease of operation, convenience of use, increased speed to change bits  
4 thereby saving time, and enhanced safety.

5 Without limiting the scope of this invention as expressed by the claims that follow,  
6 some, but not necessarily all, of its features are:

7 One, the tool of this invention includes a yoke member, a multi-component bit, and a  
8 hollow sleeve member.

9 Two, the yoke member may include a body having a shaft extending outward  
10 therefrom in one direction and a pair of spaced apart parallel arms extending outward  
11 therefrom in an opposite direction. Each arm terminates in a free end. The arms of the yoke  
12 member may be inserted into the sleeve member to straddle an elongated slit in the sleeve  
13 member and to extend through a first open end of the sleeve member. The sleeve member  
14 may be mounted on the yoke member to enable the sleeve member to be manually moved  
15 reciprocally in an axial direction,

16 Three, the multi-component bit includes a drill element and drive element. These  
17 elements may be detachably connected to the bit, and the bit may include a magnet that  
18 assists in attaching the drill and drive elements to the bit. The driver element and drill  
19 element may be aligned and axially oriented in opposed directions, and they each may have a  
20 coupling member that detachably connects each of these elements to the bit.

21 Four, the multi-component bit may include a block member. This block member may  
22 have opposed first and second sides, with the driver element detachably connected to the first  
23 side by one coupling component, and the drill element detachably connected to the second  
24 side by another coupling component. The block member may be positioned between the free  
25 ends of the arms, extending through the sleeve member and connected thereto to pivot to  
26 reverse the axial orientation of the driver and drill elements. The slit may be sized to enable  
27 at least one of the elements to pass therethrough upon pivoting of the multi-component bit.

28 Five, the sleeve member may be a co-axial with the yoke member, and the sleeve  
29 member and yoke member may rotate as a unit. The sleeve member may be moveable  
30 reciprocally and axially between a locked position preventing pivoting of the block member  
31 and an unlocked position enabling pivoting of the block member. The sleeve member may  
32 have opposed first and second open ends and a side wall having therein the elongated slit,  
33 which may have one end terminating at the first open end of the sleeve member and another

1 end terminating in an intermediate portion of the side wall. The slit may be parallel to and  
2 aligned with the drill and drive elements and may be longer than and wider than the drill and  
3 drive elements so both these elements pass through the slit as the bit is rotated. The sleeve  
4 member may have a first portion that engages the arms to enable the yoke member and sleeve  
5 member to rotate as a unit and a second portion that limits the reciprocal movement of the  
6 sleeve member between a first position and a second position. In the first position the second  
7 portion engages one of the coupling members to prevent pivoting of the multi-component bit,  
8 and in the second position the second portion disengages from the one coupling member to  
9 allow the multi-component bit to be manually pivoted to reverse the axial orientation of the  
10 drill and driver elements. The sleeve member may include a pair of opposed channels and,  
11 each arm of the yoke may be inserted into one of the channels with the arm's free end  
12 extending through an open end of the sleeve. The arms may straddle the block member,  
13 which may be connected to the free ends to pivot.

14 Six, a locking member may be used. This locking member may be within the sleeve  
15 and it may have a first portion that engages at least one of the arms to enable the yoke  
16 member and sleeve to rotate as a unit and a second portion that limits the reciprocal  
17 movement of the sleeve between the first position and the second position. The locking  
18 member may engage the bit when the sleeve is in a first position and disengage from the bit  
19 when the sleeve is moved from the first position to the second position to allow the bit to be  
20 rotated. The locking member when in the first position may engage one of the coupling  
21 members. In the second position, the locking member may engage one of the elements to  
22 prevent rotation of the multi-component bit and disengage therefrom upon the sleeve being  
23 manually moved to the second position to allow the bit to be manually rotated to reverse the  
24 orientation of the drill and driver element. The sleeve member may include an internal guide  
25 member providing a wall segment that creates a receptacle. This receptacle may have an  
26 internal surface that is at least partially cylindrical shaped to receive at least a portion of one  
27 of the coupling members to lock the block member in position, preventing pivoting of the  
28 block member until the sleeve member is moved to the unlocked position. A spring member  
29 may be within the sleeve member. This spring member is compressed upon the sleeve  
30 member being moved into the second position. The spring member returns the sleeve  
31 member to the first position upon release of the sleeve member. There may also be a collar  
32 mounted on the sleeve to free wheel.

33 Seven, a pair of compression collar members may be employed to interact with the

1 coupling members for detachably connecting the drill and drive elements of the bit. A  
2 separable coupling member is connected to each collar member. Each coupling member  
3 compresses the collar member to which it is connected, holding the element in the collar  
4 member securely until the coupling member is at least partially separated from the collar  
5 member to which it is connected. At least one of the coupling members may be interactive  
6 with the sleeve member to provide a locking function when the sleeve member is in a locked  
7 position. The sleeve member may include a guide member that receives a portion of one of  
8 the coupling members to lock the block member in position, preventing pivoting of the block  
9 member until the sleeve member is moved to the unlocked position. The compression collar  
10 members may extend outward from the block member in opposite directions substantially  
11 along a longitudinal axis of the tool when the sleeve member is in the locked position. Each  
12 collar member may be substantially cylindrical and split with external threaded surfaces.  
13 Each coupling member may have a substantially cylindrical external configuration with an  
14 internal threaded cylindrical surface so that each coupling member compresses the split collar  
15 member to which it is connected as the coupling member is screwed onto its collar member.  
16 The split compression collar members may each have a plurality of slots in a sidewall thereof  
17 and the ends of the driver and drill elements may each have a base section with corners that  
18 slide into the slots upon inserting these elements into the collar members.

19 These features are not listed in any rank order nor is this list intended to be  
20 exhaustive.

21

22

### DESCRIPTION OF DRAWING

23

24 Some embodiments of this invention, illustrating all its features, will now be  
25 discussed in detail. These embodiments depict the novel and non-obvious drilling and  
26 driving tool of this invention as shown in the accompanying drawing, which is for illustrative  
27 purposes only. This drawing includes the following figures (Figs.), with like numerals  
28 indicating like parts:

29

30 Fig. 1 is a perspective view of the tool according to one embodiment of this invention.

31

32 Fig. 2 is a side view of the tool shown in Fig. 1 illustrating the locked position of the  
33 tool.

1 Fig. 3 is top view of the tool shown in Fig. 2 illustrating moving a sleeve to an  
2 unlocked position.

3 Fig. 4 is an exploded perspective view of the tool shown in Fig. 1.

4 Fig. 4A is a fragmentary, exploded perspective view of a block and associated yoke  
5 arms of the tool shown in Fig. 1.

6 Fig. 5 is an exploded side view of the tool shown in Fig. 2.

7 Fig. 6 is a bit-end view of the tool taken along line 6-6 in Fig. 2.

8 Fig. 7 is a drill-end view of the tool taken along line 7-7 in Fig. 2.

9 Fig. 8A is a perspective view of one embodiment of a sleeve used with the tool shown  
10 in Fig. 1.

11 Fig. 8B is a cross-sectional view of the sleeve taken along line 8B-8B of Fig. 8A.

12 Fig. 8C is a cross-sectional view of the sleeve taken along line 8C-8C of Fig. 8A.

13 Fig. 9 is a cross-sectional view of the tool taken along line 9-9 of Fig. 2, showing the  
14 drill element extended and the tool in the locked position.

15 Fig. 9A is a cross-sectional view of the tool similar to that of Fig. 9 but showing the  
16 driver element extended and the tool in the unlocked position.

17 Fig. 9B is a fragmentary cross-sectional view showing a detent mechanism.

18 Fig. 10 is a cross-sectional view of the tool taken along line 10-10 of Fig. 4A.

19 Fig. 11 is a side view of a drill element used with the tool of this invention.

20 Fig. 12 is a cross-sectional view taken along line 12-12 of Fig. 11.

21 Fig. 13 is a side view of a driver element used with the tool of this invention.

22 Fig. 14 is a cross-sectional view taken along line 14-14 of Fig. 13.

23 Fig. 15 is a perspective view of an alternate embodiment of a sleeve used with the tool  
24 shown in Fig. 1.

25 Fig. 16 is a top plan view of the sleeve shown in Fig. 15

26 Fig. 17 is a cross-sectional view of the sleeve shown in Fig. 16 taken along line 17-17  
27 of Fig. 16.

28 Fig. 18 is a bit-end view of the sleeve shown in Fig. 16 taken along line 18-18 of Fig.  
29 15.

30 Fig. 19 is a cross-sectional view of the sleeve shown in Fig. 16 taken along line 19-19  
31 of Fig. 18.

32 Fig. 20 is a cross-sectional view of the sleeve shown in Fig. 16 taken along line 20-20  
33 of Fig. 19.

1 Fig. 21 is a perspective view of the tool of this invention attached to a power drill.  
2

3 DETAILED DESCRIPTION OF SOME EMBODIMENTS OF THIS INVENTION  
4

5 Fig. 1 illustrates one embodiment of this invention, the tool 10. This tool 10 includes  
6 a yoke 12 having arms 44 and 46 (Fig. 4) extending through a sleeve 14 carried by the yoke  
7 and a multi-component bit 16 including a drill element 24 (Figs. 11 and 12) and a driver  
8 element 26 (Figs. 13 and 14) that are axially aligned with each other and lie along the  
9 longitudinal axis X of the tool 10. The drill element 24 and a driver element 26 are each  
10 respectively received within split, threaded compression collars 36 and 38 (Fig. 4A)  
11 extending outward in opposite directions from a block 22 disposed along the axis X between,  
12 and attached to, rounded, outer free ends 44a and 46a (Fig. 4) of the arms 44 and 46 of the  
13 yoke 12.

14 After inserting the drill element 24 and driver element 26 into the compression collars  
15 36 and 38, thumbnuts 40 and 41 are, respectively, manually screwed onto the compression  
16 collars 36 and 38 to hold these elements securely in position. Unloosening these thumbnuts  
17 40 and 41 enables the drill element 24 and a driver element 26 to be manually removed and  
18 replaced as desired. As depicted in Fig. 4, the thumbnuts 40 and 41 may each comprise a  
19 cylindrical body having a passageway 40a with a threaded inner surface (not shown)  
20 extending from an outer end 40b (Fig. 5) to an inner end 40c (Fig. 5). The thumbnuts 40 and  
21 41 may have a knurled outer surface 40e comprising multitude ridges 40d that aid a user to  
22 grasp the thumbnuts.

23 A locking mechanism is provided to lock the block 22 and the attached multi-  
24 component bit 16 in one of the following selected positions: In position 1, as shown in Fig. 9,  
25 the drill element 24 extends outward in a ready to use position, or in position 2, as shown in  
26 Fig. 9A, the driver element 26 extends outward in a ready to use position. As discussed  
27 subsequently in greater detail, the unique internal configuration of the sleeve 14 interacts  
28 with an outer smooth annular rim R (Fig. 4) of one of the thumbnuts 40 and 41 to provide the  
29 locking mechanism. As shown in Fig. 2, the block 22 is mounted to pivot to reverse the  
30 positions of the drill element 24 and driver element 26. To achieve this, first the sleeve 14 is  
31 manually moved from a locked position as shown in Fig. 9 axially along the yoke 12 to  
32 compress a spring 20 seated inside the yoke 12. As shown in 9A, this unlocks the locking  
33 mechanism, allowing the multi-component bit 16 to be manually pivoted and rotated in a

1 clockwise direction as shown in Fig. 2 to reverse the orientation of the drill element 24 and  
2 drive element 26. A drive element 26 that is relatively short in length clears the bit-end of the  
3 sleeve 14 as the multi-component bit 16 rotates with this sleeve in the unlocked position. (As  
4 discussed subsequently in greater detail, when a drive element that is relatively long is  
5 employed, an alternate embodiment of the sleeve shown in Figs. 15 through 20 is used.)  
6 When the drill and drive elements 24 and 26 are reversed, but again aligned along the  
7 longitudinal axis X, the user releases his or her grasp of the sleeve 14 and the spring 20  
8 returns the sleeve 14 to the locked position shown in Fig. 9.

9 Typically, the block 22 and compression collars 36 and 38 are a unitary metallic  
10 structure made by conventional machining processes. As best illustrated in Fig. 4A, the block  
11 22 is substantially brick shaped, having a pair of opposed flat sidewalls 28a, 28b, a pair of  
12 opposed rounded sidewalls 30a, 30b, a flat walled drill-side 32a, and a flat walled driver-side  
13 32b. A hole 34 extends between the pair of opposed flat sidewalls 28a, 28b and may be  
14 centrally located between the pair of opposed, rounded walls 30a, 30b and the drill-side 32a  
15 and the driver-side 32b. The compression collars 36 and 38 each have six longitudinal slots  
16 37 equally spaced apart to correspond to corners of a hexagonal shaped connector.

17 Referring to Figs. 4, 5 and 7, the yoke 12 includes a yoke body 42 with the arms 44,  
18 46 extending outward in one direction from this yoke body 42 and a shaft 52 extending  
19 outward in the opposite direction. The shaft 52 may have a hexagonal cross-section. The  
20 yoke body 42 is substantially cylindrical having a bit-end 42a and a drill-end 42b. The drill-  
21 end 42b may contain a hole 50 in the yoke body 42 into which a bit-end 52a of the shaft 52 is  
22 force fitted. For example, the bit-end 52a may be seated in a plug 53 (Fig. 9A) and the plug  
23 forced into the hole 50. The drill-end 52b of the shaft 52 is inserted into a power drill PD  
24 shown in Fig. 21 when the tool 10 is connected to this power drill.

25 As best shown in Fig. 4A, the pair of yoke arms 44, 46 extend perpendicularly from  
26 the bit-end 42a (Fig. 5) of the yoke body 42 and are substantially parallel. The arms 44, 46  
27 are directly opposite each other and each has a substantially rectangular configuration. Each  
28 arm 44, 46 may have a hole 44b, 46b located near the rounded outer end 44a, 46a of each  
29 arm, and these holes 44b, 46b are aligned. Each hole 44b, 46b may lie in one of a pair of  
30 recessed portions 44c, 46c of each arm located on the outer surface 44d, 46d of each arm,  
31 respectively. The depth of each recessed portion 44c, 46c may be equal to the thickness of the  
32 heads H of a pair of connector pins 54, 55 that pass through the holes 44b, 46b, respectively.  
33 The block 22 is fastened to the yoke 12 by placing it between the yoke arms 44 and 46,

1 aligning a hole 34 through the block with holes 44b, 46b, and passing the pin 54 through hole  
2 44b, and the pin 55 through hole 46b. The pin 54 has its inner end screwed or force fitted into  
3 a cavity in an inner end of the other pin 55, so that, upon connection, these pins are joined  
4 together and provide a fulcrum about which the block 22 pivots. Adjacent the holes 44b is an  
5 aperture 44f that is part of a dent mechanism discussed subsequently in greater detail in  
6 connection with Fig. 9B.

7 Referring to Figs. 4, 8A, 8B, and 8C, the sleeve 14 is a cylindrically shaped body 58  
8 (Fig. 8A) having a lip 60 at the drill-end 14c. This lip 60 prevents axial movement in a  
9 direction towards the shaft 52 of a cylindrical gripping member 70 co-axially mounted on the  
10 sleeve 14. As shown in Fig. 5, the cylindrical gripping member 70 has an inner radius  $r_1$  that  
11 is greater than the outer radius  $r_2$  of the sleeve 14, such that the cylindrical gripping member  
12 70 may free wheel on the sleeve. A C-clip 88 prevents axial movement in a direction towards  
13 the block 22 of the gripping member 70. In an intermediate portion of the yoke body 42 there  
14 is a partially circular groove 14e with orifices 86b and 86c (Fig. 4) at its opposed ends. The  
15 opposed ends 88a and 88b of the C-clip 88 are pushed into these orifices 86b and 86c with  
16 the C-clip 88 bowed slightly to create tension to hold it securely in place. This manner of  
17 mounting the gripping member 70 to free wheel on the sleeve 14 enables a user to hold the  
18 gripping member with one hand while holding the power drill with his or her other hand. The  
19 outer surface 70c of the gripping member 70 may have knurled surface including ridges 70d  
20 that aid a user to grasp this gripping member.

21 As best illustrated in Figs. 8A, 8B, and 8C, the sleeve 14 includes a cylindrical wall  
22 14a forming an internal passageway 66 between the bit-end 14b and the drill-end 14c of the  
23 sleeve 14. A slit 68 intersects the wall 14a, extending from the bit-end 14b of the sleeve 14  
24 and terminating in an intermediate portion of the wall about midway between the bit-end 14b  
25 and the drill-end 14c of the sleeve. The width  $w_1$  of the slit 68 is greater than the diameter  $d_1$   
26 of the drill 24a of the drill element 24. An internal guide member 77 within the wall 14a, and  
27 integral therewith, provides wall segments 77a, 77b, 77c that create an opened ended  
28 receptacle 79 that forms part of the locking mechanism. This internal guide member 77 also  
29 forms a pair of opposed, open sided internal channels 62, 64 for the yoke arms 44, 46. The  
30 channel 62 is on one side of the receptacle 79 and the channel 64 on the other side of the  
31 receptacle.

32 The guide member 77 projects inward from the bit-end 14b of the sleeve 14 towards  
33 the drill-end 14c of the sleeve 14, terminating in a ledge 75a (Fig. 9) that is nearly halfway

1 between the bit-end 14b and drill-end 14c of the sleeve. As shown in Fig. 9, projecting from  
2 this ledge 75a are opposed fingers 75b and 75c that fit into an inner end of the coiled spring  
3 20 to maintain the axial alignment of the spring, preventing sideways drift of the spring  
4 during movement of the sleeve 14. The wall segments 77a, 77b, 77c forming the internal  
5 guide member 77 have curved surfaces that are sections of a cylinder, the receptacle 79 has,  
6 at least in part, a cylindrical shape. Because of its substantially cylindrical configuration, the  
7 receptacle 79 is adapted to receive the outer smooth annular rim R of the thumbnut 40 or  
8 thumbnut 41, as the case may be, upon locking the multi-component bit 16 in position with  
9 the drill element 24 and drive element 26 aligned with the longitudinal axis X. When in the  
10 locked position with the drill and drive elements 24 and 26 aligned with the longitudinal axis  
11 X, a raised knurled cylindrical portion P of the thumbnut 40 or thumbnut 41 is received in the  
12 receptacle 79 and abuts an edge E (Fig. 9) forming an open mouth of the receptacle 79. Each  
13 open channel 62, 64 is adjacent an outer side 14d of the sleeve 14, has an outer surface that is  
14 a segment of a cylinder, and is open ended at both the bit-end 14b of the sleeve and the drill-  
15 end 14c of the sleeve. The yoke arms 44 and 46 are inserted through the channels 62 and 64,  
16 respectively. When inserted, the yoke arms 44 and 46 are sufficiently spaced from the walls  
17 forming the curved channels 62 and 64 to allow the sleeve 14 to slide axially, but the fit  
18 between them is sufficiently tight to prevent rotation of the sleeve relative to the yoke arms.  
19 Thus, the sleeve 14 with the yoke arms 44 and 46 extending therethrough rotate as a unit.

20 As illustrated in Figs. 11 and 12, the drill element 24 is of conventional design  
21 including a housing 23 having a passageway 23a therethrough. The housing 23 includes a  
22 countersink portion 23f and a mounting base portion 24b having a hex nut section 23c with  
23 six corners 23d. The housing holds the drill 24a, which is removable. The drill 24a extends  
24 through the passageway 23a and is held in position in the housing 23 by an Allen screw 25.  
25 As illustrated in Figs. 13 and 14, the driver element 26 is of conventional design including a  
26 driving head portion 26a and base portion 26b having a hexagonal cross-section with six  
27 corners 26c. Examples of such a drill element 24 and driver element 26 are sold by the  
28 Alltrade Tools LLC, among others.

29 The drill element 24 and driver element 26 are coupled to the block 22 to lie opposed  
30 to each other by inserting the base portions 24b, 26b, respectively, into the compression  
31 collars 36, 38. The corners of these base portions 24b, 26b are aligned to slide into the slots  
32 37 in the compression collars 36, 38. The drill element 24 and driver element 26 may also be  
33 magnetically attached to the block 22. As depicted in Fig. 10, disk-shaped magnets 84a and

1 84b may be lodged in a fixed location within the block 22. These magnets 84a and 84b will  
2 pull the metallic base portions 24b, 26b, respectively, of drill element 24 and drive element  
3 26 into the compression collars 36, 38.

4 As an optional feature, a conventional detent mechanism 101 shown in Fig. 9B  
5 provides, upon moving the multi-component bit 16 from an unlocked to a locked position, a  
6 snapping sound or feel to notify a user when the block 22 is properly positioned and drill  
7 element 24 and driver element 26 are axially aligned. This detent mechanism 101 includes a  
8 spring 90, a ball 92, and a hemispherical indentation 94 in the block 22 in which the ball is  
9 seated. The spring 90 passes through the aperture 44f and bears against the ball 92. The  
10 head H of the pin 54 holds this assembly together when connected to the pin 55.

### 11 12 Alternate Sleeve

13  
14 As shown in Figs. 15 through 20, a sleeve 100 may be used instead of the sleeve 14.  
15 One difference between these two sleeves 14 and 100 is that the sleeve 100 is stronger,  
16 because it uses closed channels 102 and 104. The arms 46 and 44 of the yoke 12  
17 respectively extend through these channels 102 and 104. Another difference between these  
18 two sleeves 14 and 100 is that the sleeve 100 has a short slit 106 opposite the slit 68. This  
19 short slit 106 accommodates a longer driver element (not shown) than the driver element 26.  
20 Specifically, if a long driver element is used, with the sleeve 14 pulled towards the shaft 52  
21 during unlocking and the multi-component bit 16 rotated clockwise as shown in Fig. 2, the tip  
22 of the long driver element will strike the wall 14a, preventing reversal of the orientation of  
23 the drill element 24 and driver element 26. The short slit 106 provides an opening to enable  
24 the long driver element to pass therethrough when the multi-component bit 16 is rotated  
25 clockwise as shown in Fig. 2.

### 26 27 In Use

28  
29 The tool 10 is used to drill a hole and then drive a screw or other type of fastener into  
30 the drilled hole if desired. As shown in Fig. 9, the tool 10 is in a drill-ready position with the  
31 drill element 24 positioned externally of the sleeve 14 which is in a forward position, and the  
32 multi-component bit 16 in a locked position where the rim R of thumbnut 41 of the driver  
33 element 26 is within the receptacle 79 and its raised portion P abutting the edge E (Fig. 9) of

1 the receptacle 79.

2 To drive, for example, a Phillips head screw (not shown) the driver element 26 is used  
3 in the multi-component bit 16. The tool 10 is unlocked by the user with one hand grasping  
4 the exposed portions of the arms 44 and 46 of the sleeve 14 and with his or her other hand  
5 grasping the sleeve and pulling it towards the shaft 52. This withdraws the thumbnut 41 from  
6 the receptacle 79, allowing the user to now pivot the block 22, rotating the multi-component  
7 bit 16 clockwise as shown in Fig. 2. The user rotates the block 22 until the drill 24a passes  
8 through the slit 68 and is aligned with the longitudinal axis X. This changes the orientation  
9 of the drill element 24 and the driver element 26 so they reverse positions as shown in Fig,  
10 9A. The detent mechanism 101 notifies the user when proper orientation is achieved. The  
11 user now releases his or her grasp of the sleeve 14 and the spring 20 pushes the sleeve 14  
12 towards the repositioned drill element 26. As the sleeve 14 advances, the rim R of the  
13 thumbnut 40 is pushed into the receptacle 79 with its raised portion P abutting the edge E of  
14 the receptacle 79, locking the tool 10 in position with the driver element 26 in a ready to use  
15 position. Because a sort driver element 26 is used, it clears the sleeve 14 as discussed above.  
16 If a long driver element is used, the sleeve 100 is substituted for the sleeve 14.

17 To again reverse the orientation of the driver element 26 and drill element 24, the  
18 sleeve 14 is again pulled towards the shaft 52. The user now rotates the multi-component bit  
19 16 counter-clockwise as viewed in Fig. 2, so the drill 24a moves from within the sleeve 14  
20 and passes through the slit 68. This counter-clockwise rotation is continued until the drill  
21 element 26 is aligned with the longitudinal axis X. The detent mechanism 101 again notifies  
22 the user that the axial alignment is correct, and the user releases his or her grasp of the sleeve  
23 14. The spring 20 now pushes the sleeve 14 into engagement with the thumbnut 41, which is  
24 reinserted into the receptacle 79 as discussed above.

1  
2  
3  
4  
5  
6  
7  
8  
9  
10  
11  
12  
13  
14  
15  
16  
17  
18  
19  
20  
21  
22  
23  
24  
25  
26  
27  
28  
29  
30  
31  
32  
33

CLAIMS

1. A tool including

a yoke member including a body having a shaft extending outward therefrom in one direction and a pair of spaced apart parallel arms extending outward therefrom in an opposite direction, each said arm terminating in a free end,

a hollow sleeve member having opposed first and second open ends and a side wall having therein an elongated slit with one end terminating at the first open end of the sleeve member and another end terminating in an intermediate portion of the side wall,

said arms of the yoke member being inserted into the sleeve member to straddle the slit and to extend through said first open end of the sleeve member, said sleeve member being mounted on the yoke member to enable the sleeve member to be manually moved reciprocally in an axial direction,

a multi-component bit having a block member including opposed first and second sides, a driver element detachably connected to the first side by a first coupling component, and a drill element detachably connected to the second side by a second coupling component, said driver element and drill element being aligned and axially oriented in opposed directions,

said block member positioned between the free ends of the arms extending through the sleeve member and connected thereto to pivot to reverse the axial orientation of the driver and drill elements, with the slit sized to enable at least one of the elements to pass therethrough upon pivoting of the multi-component bit,

said sleeve member having a first portion that engages the arms to enable the yoke member and sleeve member to rotate as a unit and a second portion that limits the reciprocal movement of the sleeve member between a first position where said second portion engages one of the coupling members to prevent pivoting of the multi-component bit and a second position where said second portion disengages from said one coupling member to allow the multi-component bit to be manually pivoted to reverse the axial orientation of the drill and driver elements, and

a spring member within the sleeve member that is compressed upon the sleeve member being moved into said second position, said spring member returning the sleeve member to the first position upon release of the sleeve member.

- 1
- 2     **2.     A tool including**
- 3             a yoke member and a sleeve mounted on the yoke member to move reciprocally in an
- 4 axial direction, said yoke member and sleeve being connected to rotate as a unit,
- 5             said yoke member including a pair of arms that each have a free end, said arms being
- 6 inserted into the sleeve with their free ends extending through an open end of the sleeve,
- 7             a multi-component bit including a driver element and a drill element that are axially
- 8 aligned and oriented to extend outward in opposite directions,
- 9             said multi-component bit being mounted to the free ends of the arms to be manually
- 10 rotated to reverse the axial orientation of the driver and drill elements,
- 11             said sleeve including an elongated slit through which one of said elements passes as
- 12 the bit is rotated, and
- 13             a locking member that engages the bit when the sleeve is in a first position and
- 14 disengages from the bit when the sleeve is moved from the first position to a second position
- 15 to allow said bit to be rotated.
- 16
- 17     **3.     The tool of Claim 2 including a spring member within the sleeve that is compressed**
- 18 upon the sleeve being moved into said second position, said spring member returning the
- 19 sleeve to the first position upon release of the sleeve.
- 20
- 21     **4.     The tool of Claim 2 where the yoke includes a shaft extending outwardly in a**
- 22 **direction opposite to that of the arms.**
- 23
- 24     **5.     The tool of Claim 2 including a collar mounted on the sleeve to free wheel.**
- 25
- 26     **6.     The tool of Claim 2 where the drill and drive elements are detachably connected to**
- 27 **the bit.**
- 28
- 29     **7.     The tool of Claim 6 where the bit includes a magnet that assists in attaching the drill**
- 30 **and drive elements to the bit.**
- 31
- 32     **8.     The tool of Claim 6 where the drill and drive elements each have a coupling member**
- 33 **that detachably connects each of said elements to the bit, and the locking member in said first**

1 position engages one of said coupling members.  
2

3 9. A tool including

4 a yoke member and a sleeve mounted on the yoke member to move reciprocally in an  
5 axial direction between first and second positions,

6 said yoke member including a pair of arms that each have a free end and a shaft  
7 extending outwardly in a direction opposite to that of the arms, said arms being inserted into  
8 the sleeve with the free ends extending through an open end of the sleeve,

9 a multi-component bit including a detachable driver element and a detachable drill  
10 element that are axially aligned and oriented to extend outward in opposite directions,

11 said multi-component bit being mounted to the free ends of the arms to be rotated  
12 manually to reverse the axial orientation of the driver and drill elements,

13 said sleeve including an elongated slit located in a side wall of the sleeve with one  
14 arm on one side of the slit and the other arm on another side of the slit,

15 said slit being parallel to and aligned with the drill and drive elements and being  
16 longer than and wider than said drill and drive elements so said elements pass through the slit  
17 as the bit is rotated,

18 a locking member that engages the bit when the sleeve is in a first position and  
19 disengages from the bit when the sleeve is moved from the first position to a second position  
20 to allow said bit to be rotated,

21 said locking member being within the sleeve and having a first portion that engages at  
22 least one of said arms to enable the yoke member and sleeve to rotate as a unit and a second  
23 portion that limits the reciprocal movement of the sleeve between the first position and the  
24 second position,

25 said second portion of the locking member engaging one of the elements to prevent  
26 rotation of the multi-component bit and disengaging therefrom upon the sleeve being  
27 manually moved to the second position to allow the bit to be manually rotated to reverse the  
28 orientation of the drill and driver elements, and

29 a spring member within the sleeve that is compressed upon the sleeve being moved  
30 into said second position, said spring member returning the sleeve to the first position upon  
31 release of the sleeve.

32  
33 10. The tool of Claim 9 including a collar mounted on the sleeve to free wheel.

- 1  
2 11. A tool including  
3 a block member mounted to pivot on a yoke member and having a pair of  
4 compression collar members,  
5 a detachable driver element having an end inserted into one of the collar members and  
6 a detachable drill element having an end inserted into the other collar member,  
7 a sleeve member mounted on the yoke member to move between a locked position  
8 preventing pivoting of the block member and an unlocked position enabling pivoting of the  
9 block member, said yoke member and sleeve member being connected to rotate as a unit,  
10 and  
11 a separable coupling member connected to each collar member, each coupling  
12 member compressing the collar member to which it is connected, holding the element in said  
13 collar member securely until said coupling member is at least partially separated from the  
14 collar member to which it is connected.  
15
- 16 12. The tool of Claim 11 where at least one of the coupling members is interactive with  
17 the sleeve member to provide a locking function when the sleeve member is in a locked  
18 position.  
19
- 20 13. The tool of Claim 12 where the sleeve member includes a guide member that receives  
21 a portion of one of the coupling members to lock the block member in position, preventing  
22 pivoting of the block member until the sleeve member is moved to the unlocked position.  
23
- 24 14. The tool of Claim 11 where the compression collar members extend outward from the  
25 block member in opposite directions substantially along a longitudinal axis of the tool when  
26 the sleeve member is in the locked position.  
27
- 28 15. The tool of Claim 14 where the yoke member includes a pair of arms that each have a  
29 free end, said arms being inserted into the sleeve member with their free ends extending  
30 through an open end of the sleeve member, said block member being mounted between the  
31 free ends to pivot.  
32
- 33 16. The tool of Claim 14 where the sleeve member includes an elongated slit through

1 which one of said elements passes as the block member pivots.

2

3 17. A tool including

4 a block member mounted to pivot on a yoke member having an external surface  
5 comprising portions of a cylinder,

6 a pair of substantially cylindrical, split compression collar members with external  
7 threaded surfaces, said collar members extending outward from the block member in opposite  
8 directions,

9 a detachable driver element having an end inserted into one of the collar members and  
10 a detachable drill element having an end inserted into the other collar member,

11 a pair of separable coupling members, one connected to each split collar member to  
12 hold the element in said collar member securely until said coupling member is at least  
13 partially separated from the collar member to which it is connected,

14 each coupling member having a substantially cylindrical external configuration with  
15 an internal threaded cylindrical surface so that each coupling member compresses the split  
16 collar member to which it is connected as the coupling member is screwed onto said collar  
17 member, and

18 a co-axial cylindrical sleeve member connected to the yoke member so that said  
19 sleeve member and yoke member rotate as a unit, said sleeve member being moveable  
20 reciprocally and axially between a locked position preventing pivoting of the block member  
21 and an unlocked position enabling pivoting of the block member,

22 said sleeve member including an internal guide member providing a wall segment that  
23 creates a receptacle having an internal surface that is at least partially cylindrical shaped to  
24 receive at least a portion of one of the coupling members to lock the block member in  
25 position, preventing pivoting of the block member until the sleeve member is moved to the  
26 unlocked position.

27

28 18. The tool of Claim 17 where the split compression collar members each have a  
29 plurality of slots in a sidewall of the collar members and the ends of the driver and drill  
30 elements each have a base section with corners that slide into the slots upon inserting said  
31 elements into the collar members.

32

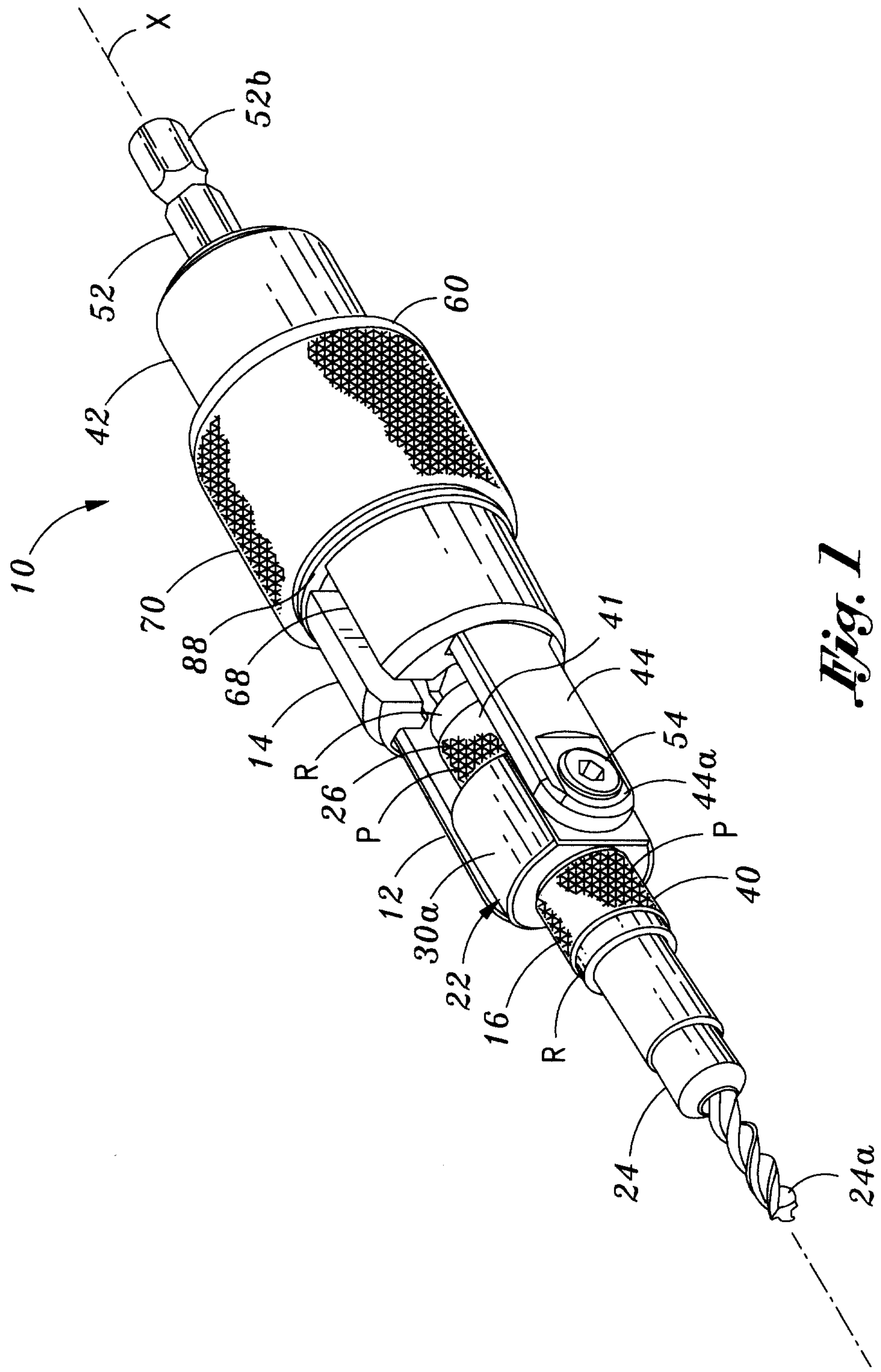
33 19. The tool of Claim 18 where the sleeve member includes a pair of opposed channels

1 and the yoke member includes a pair of arms that each have a free end, each said arm being  
2 inserted into one of said channels with its free end extending through an open end of the  
3 sleeve member, said arms straddling said block member and said block member being  
4 connected to the free ends to pivot.

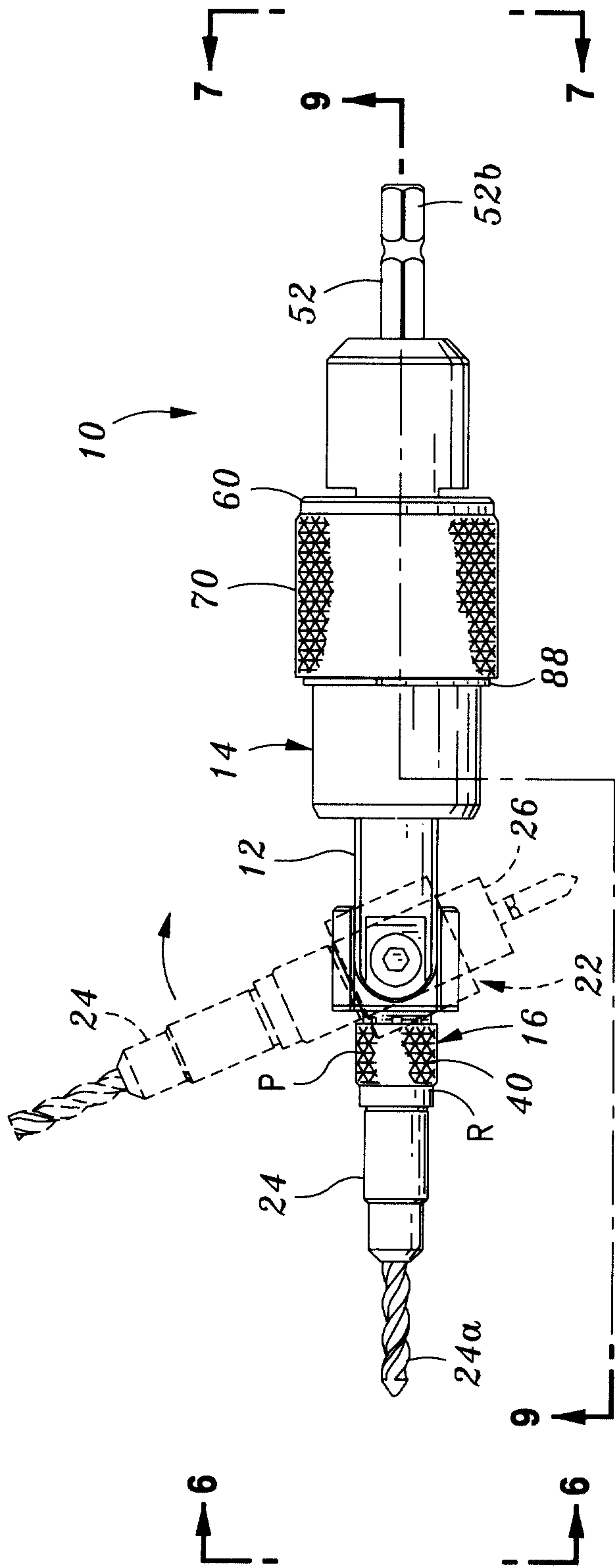
5

6 20. The tool of Claim 19 where the sleeve member includes an elongated slit through  
7 which one of said elements passes as the block pivots.

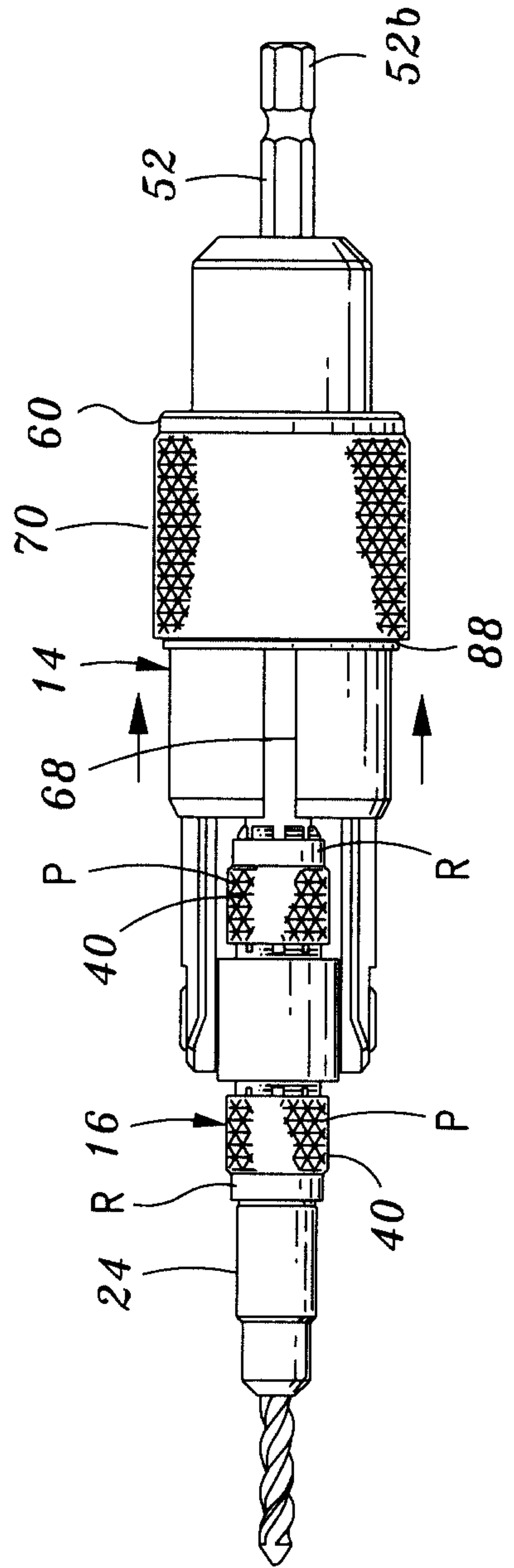
8



*Fig. 1*

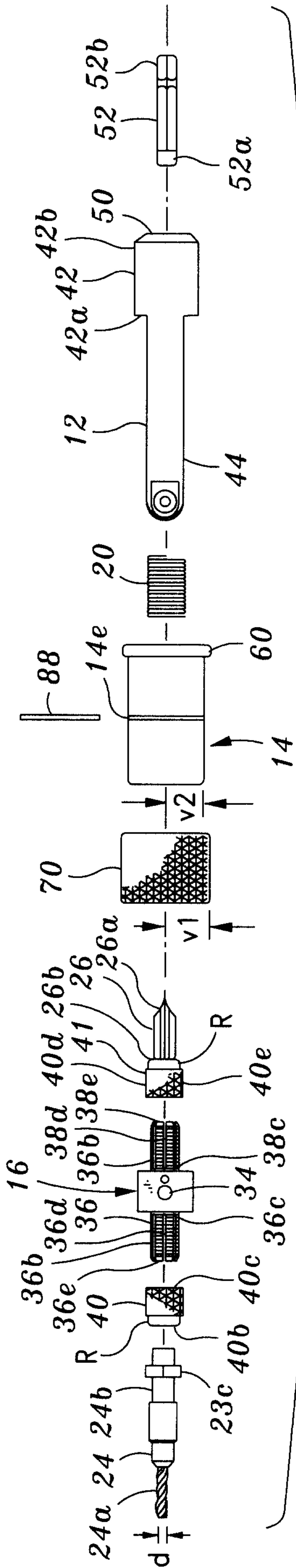


*Fig. 2*

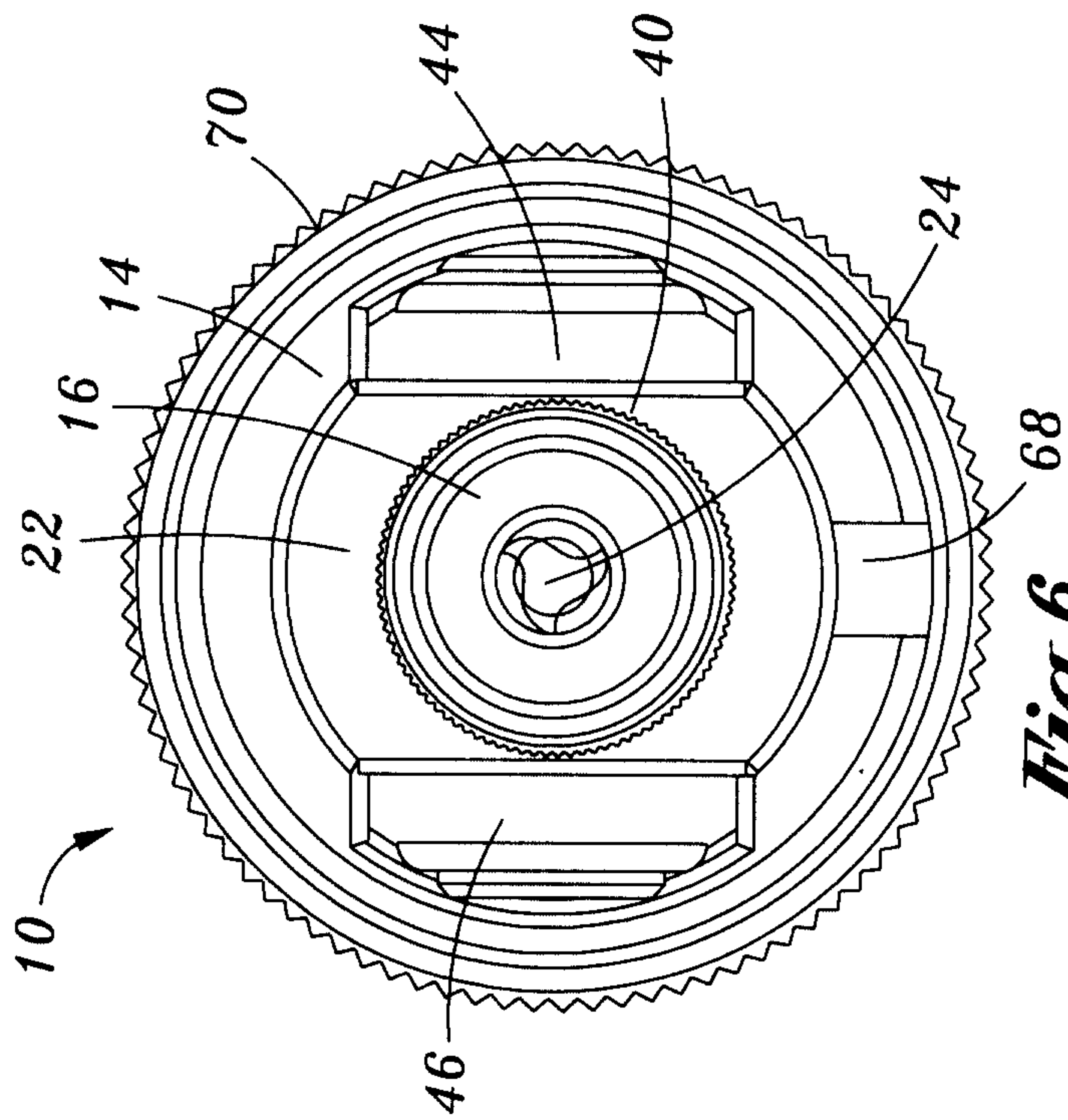


*Fig. 3*

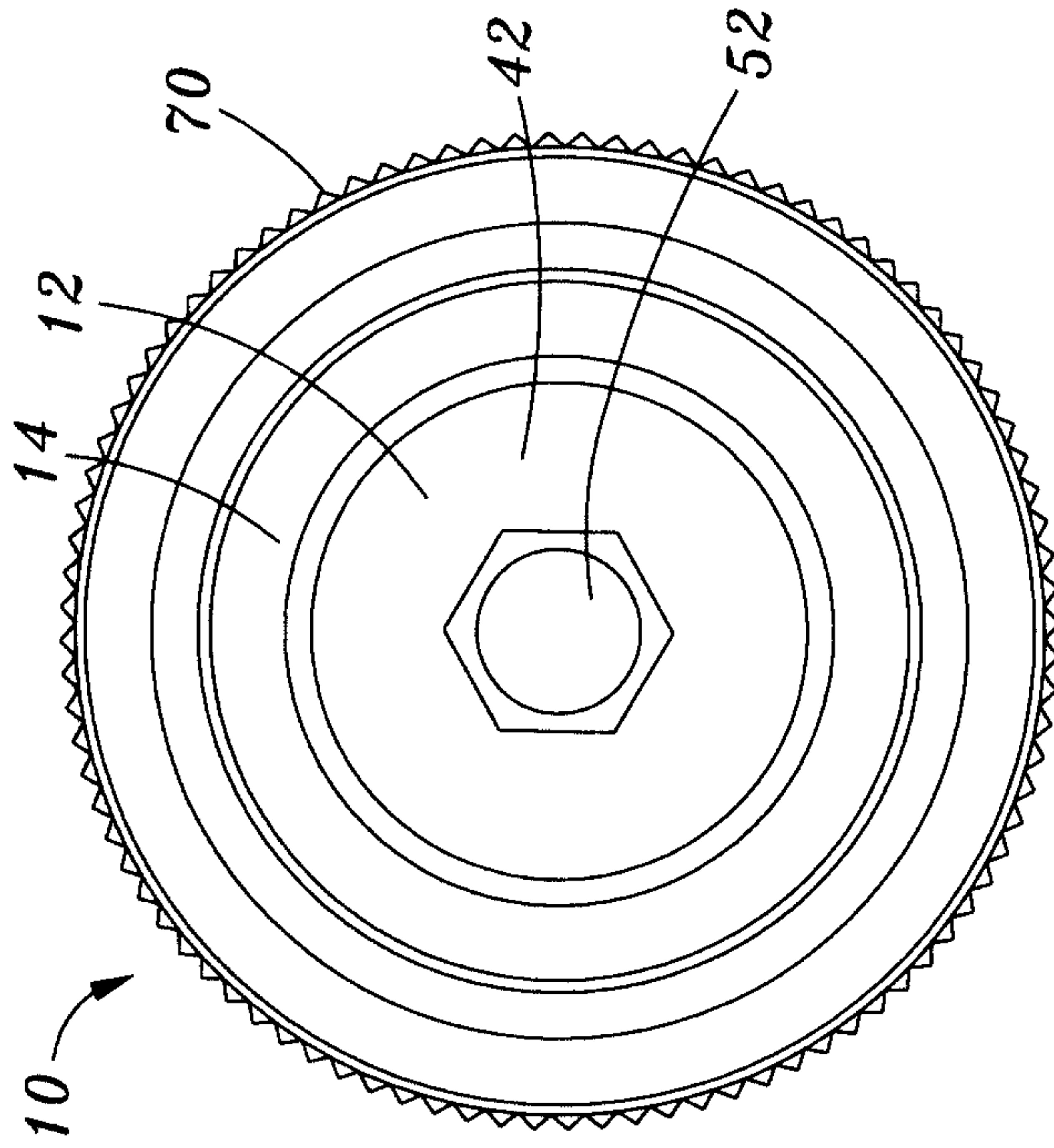




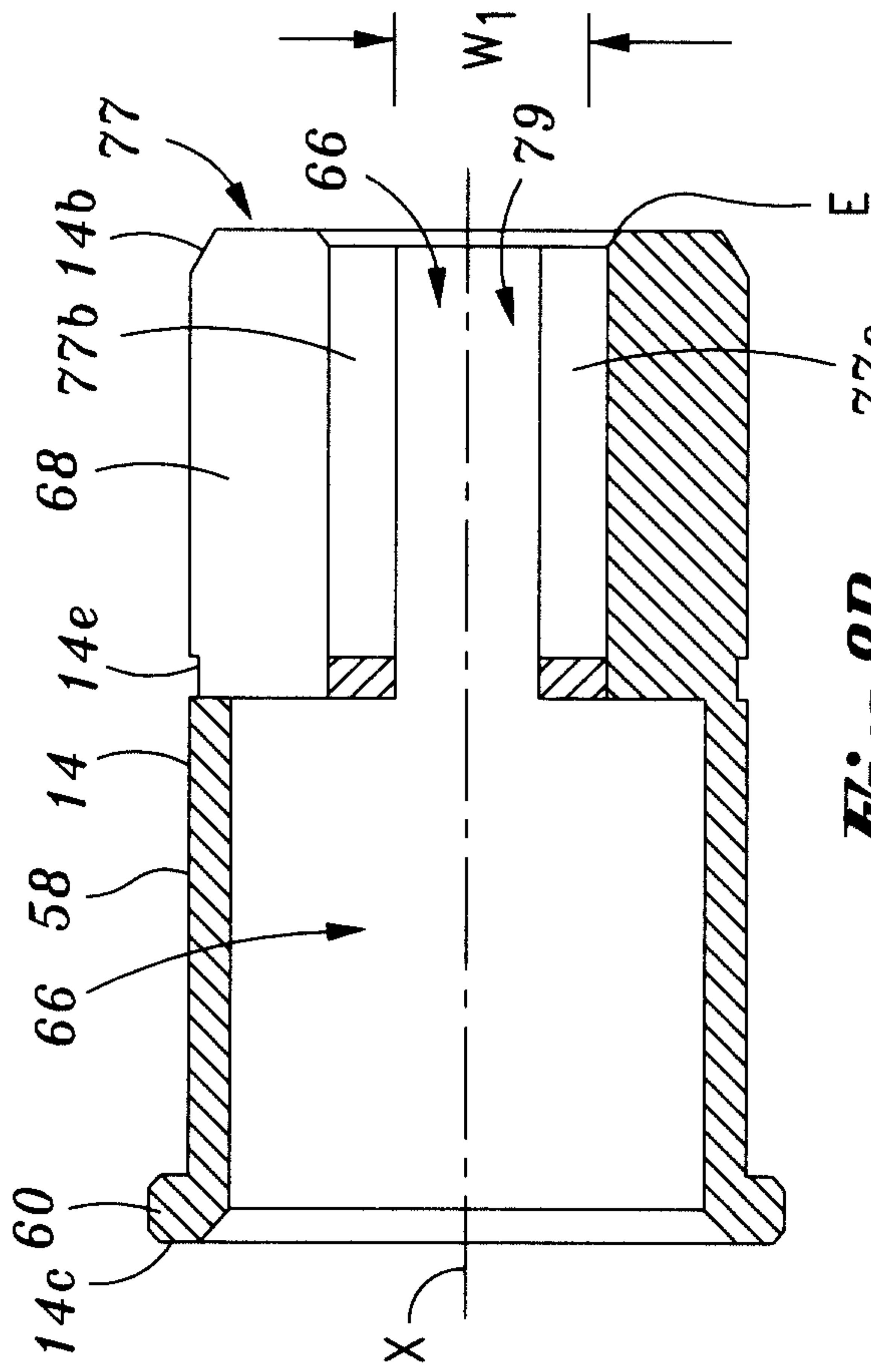
*Fig. 5*



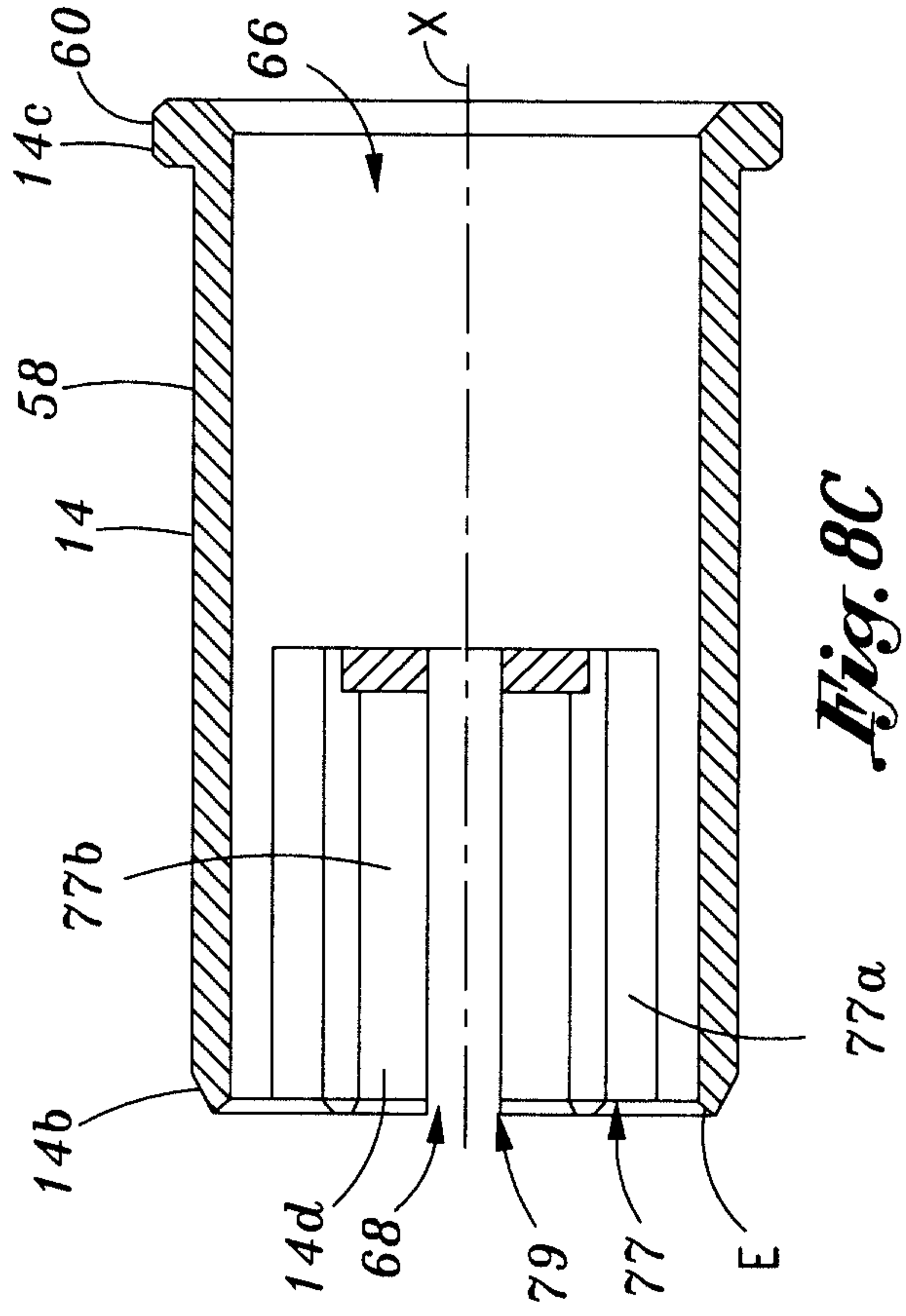
*Fig. 6*



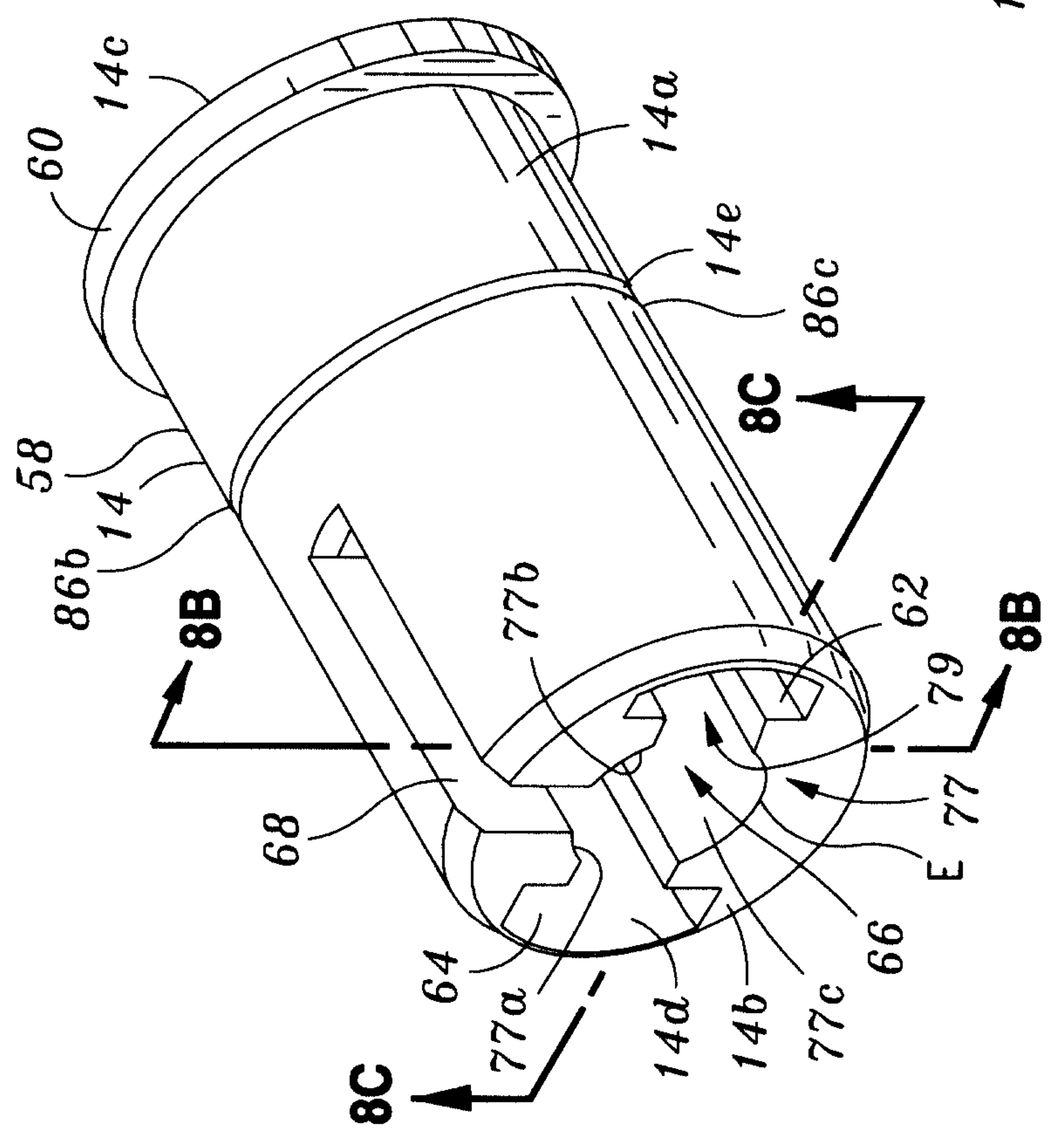
*Fig. 7*



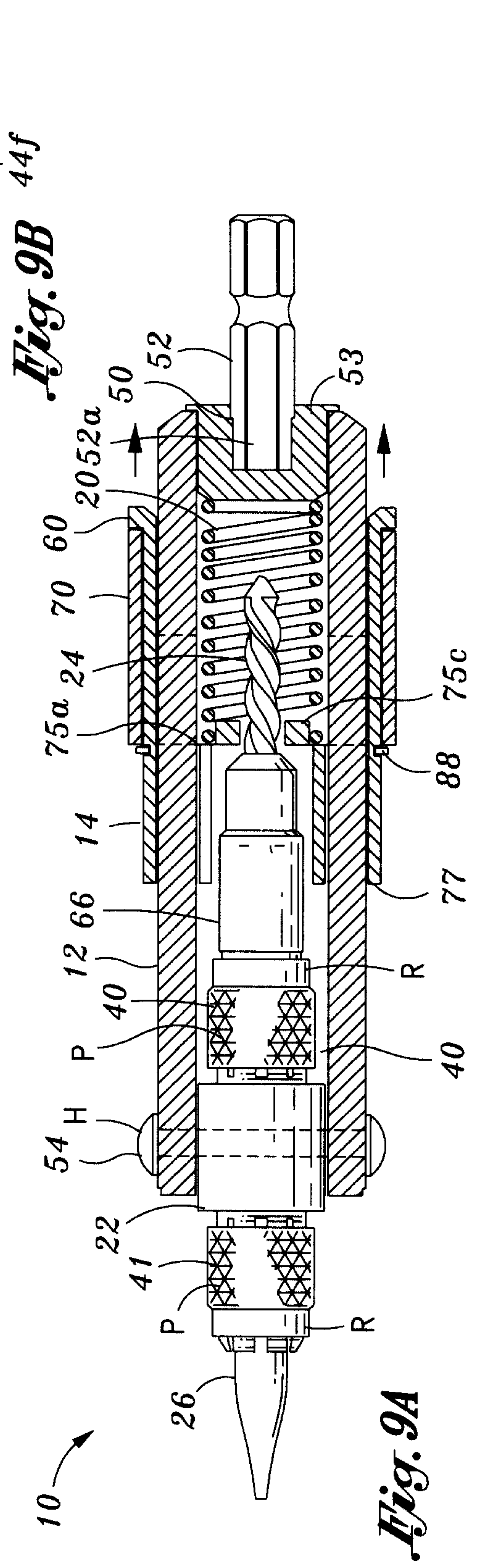
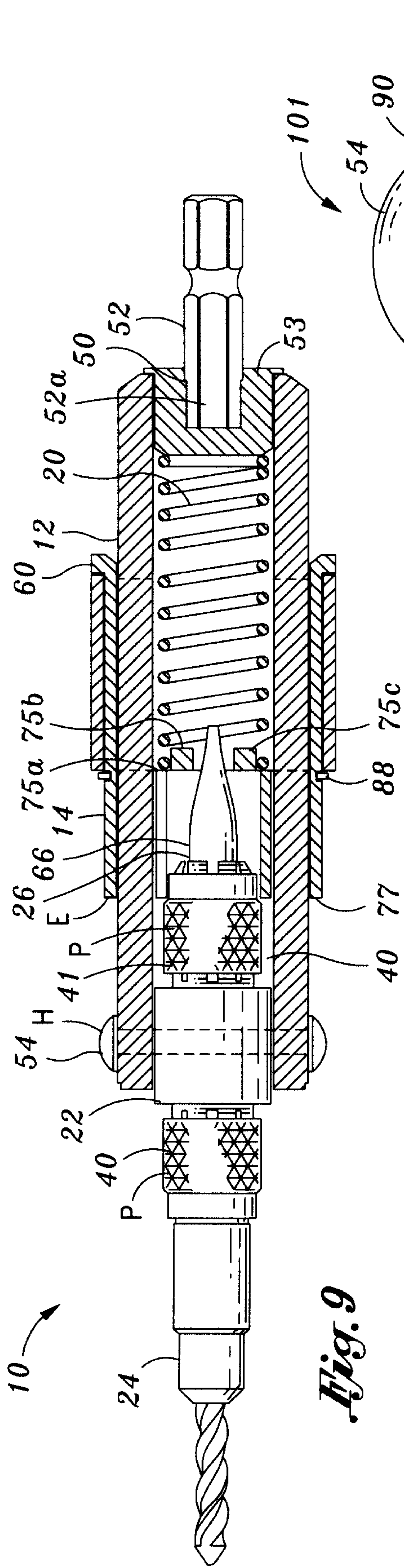
*Fig. 8B*



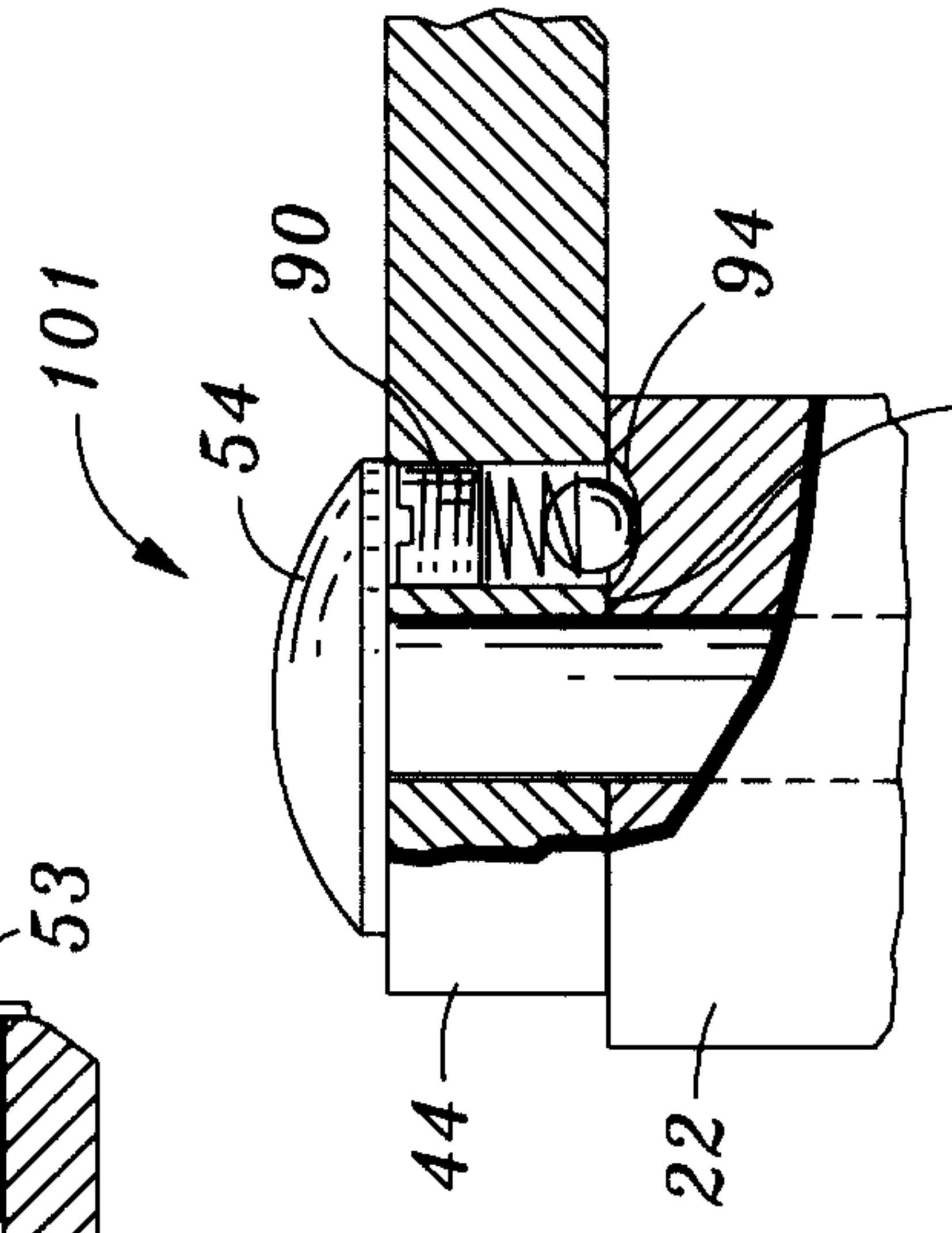
*Fig. 8C*

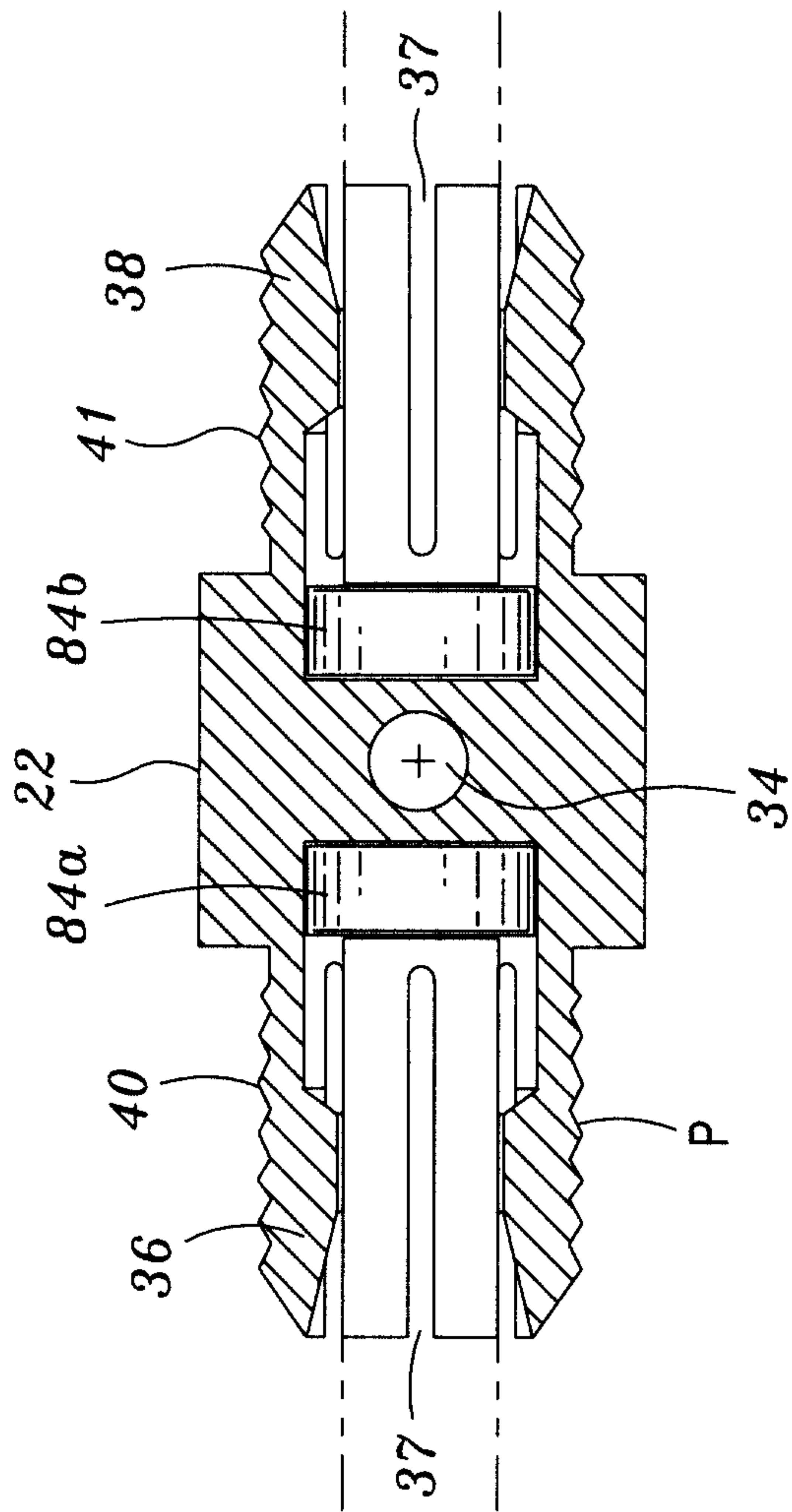


*Fig. 8A*

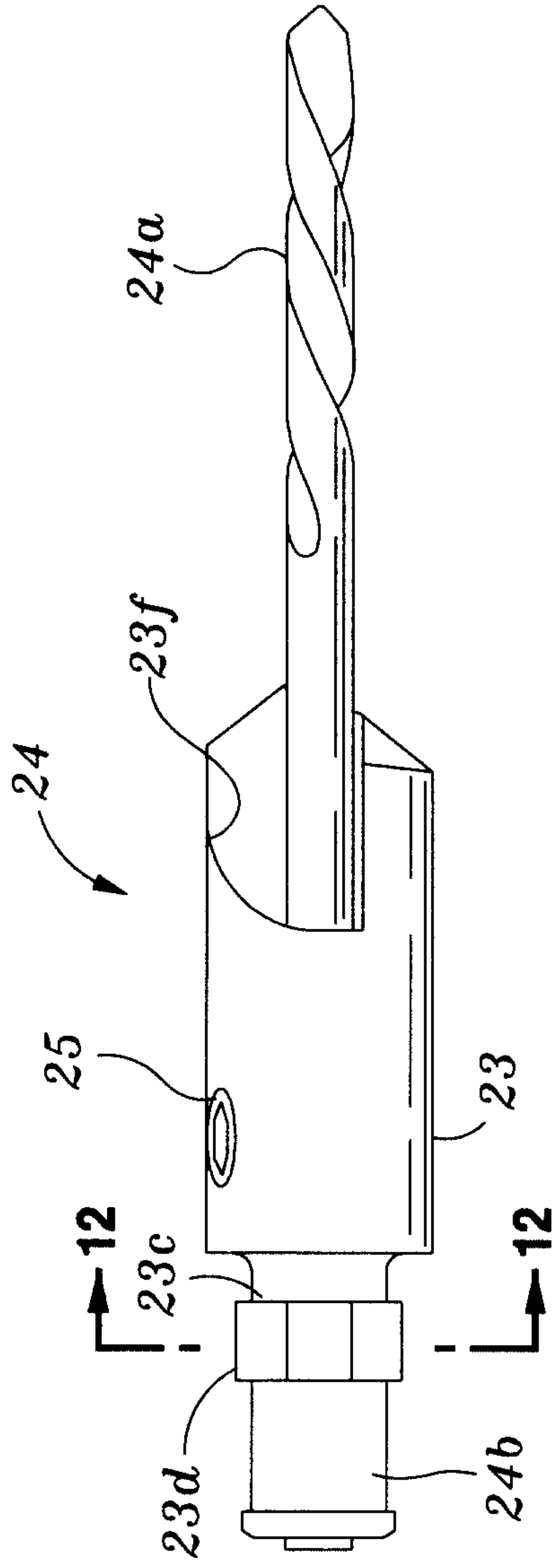


**Fig. 9B**

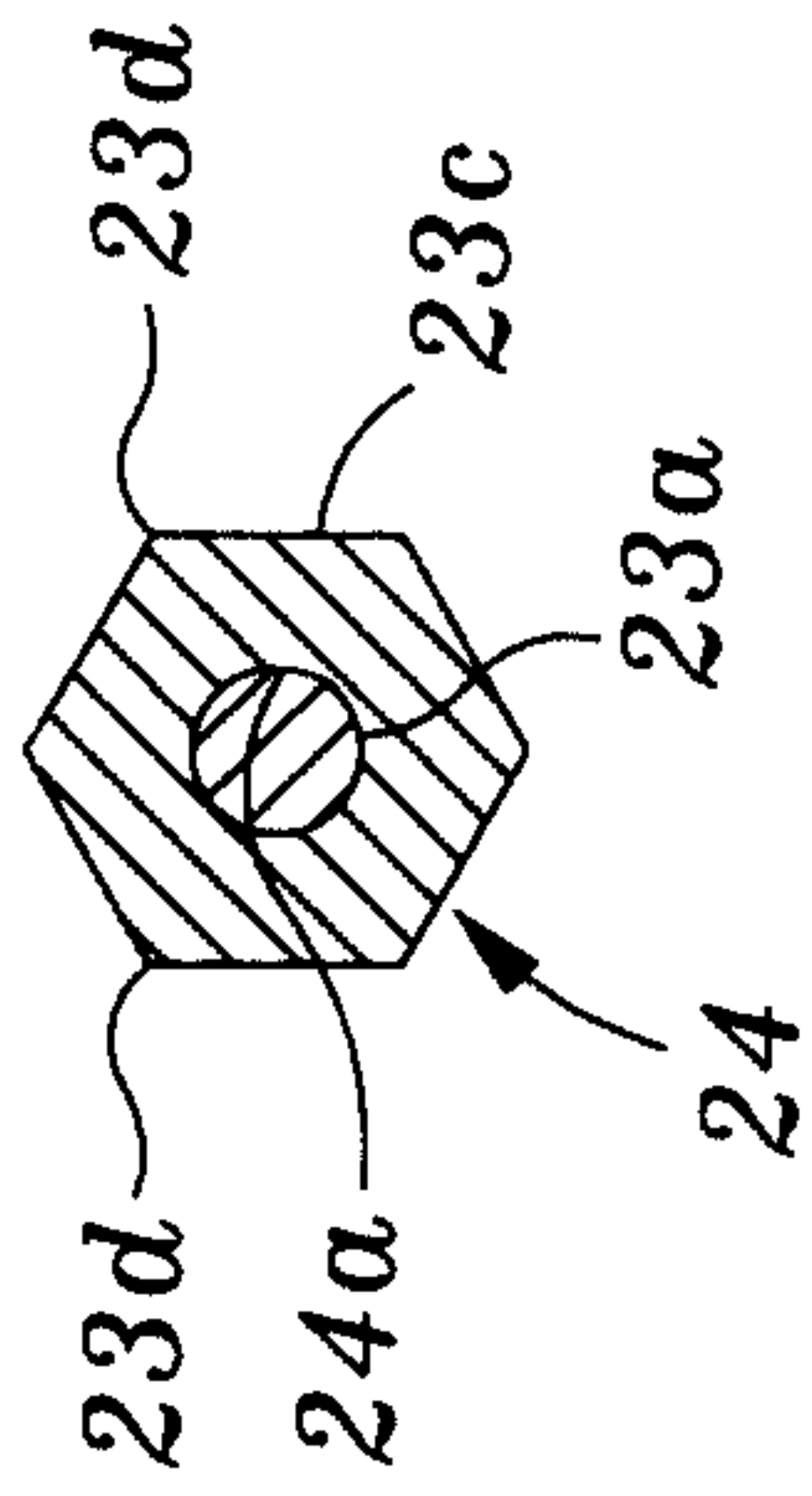




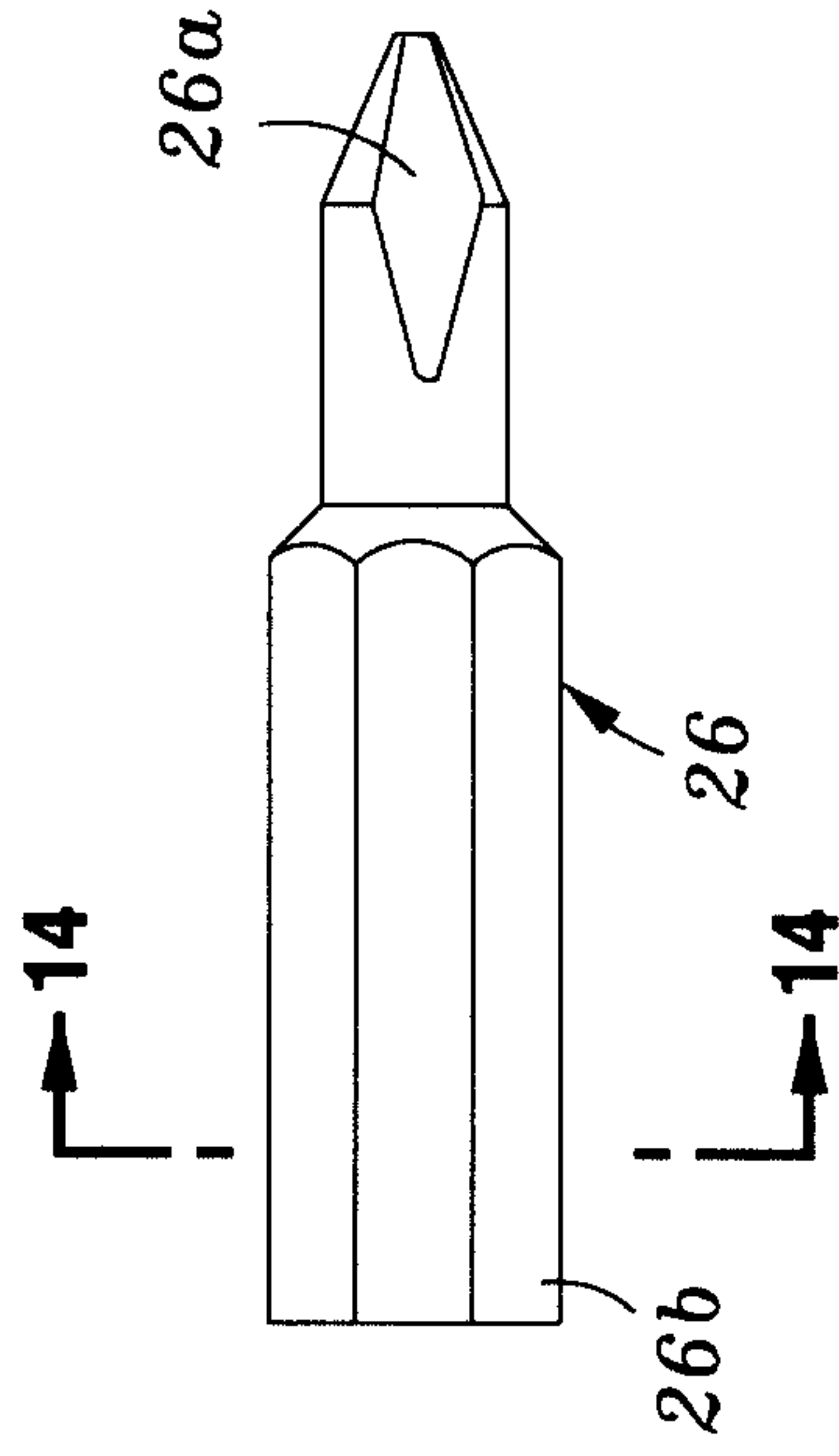
*Fig. 10*



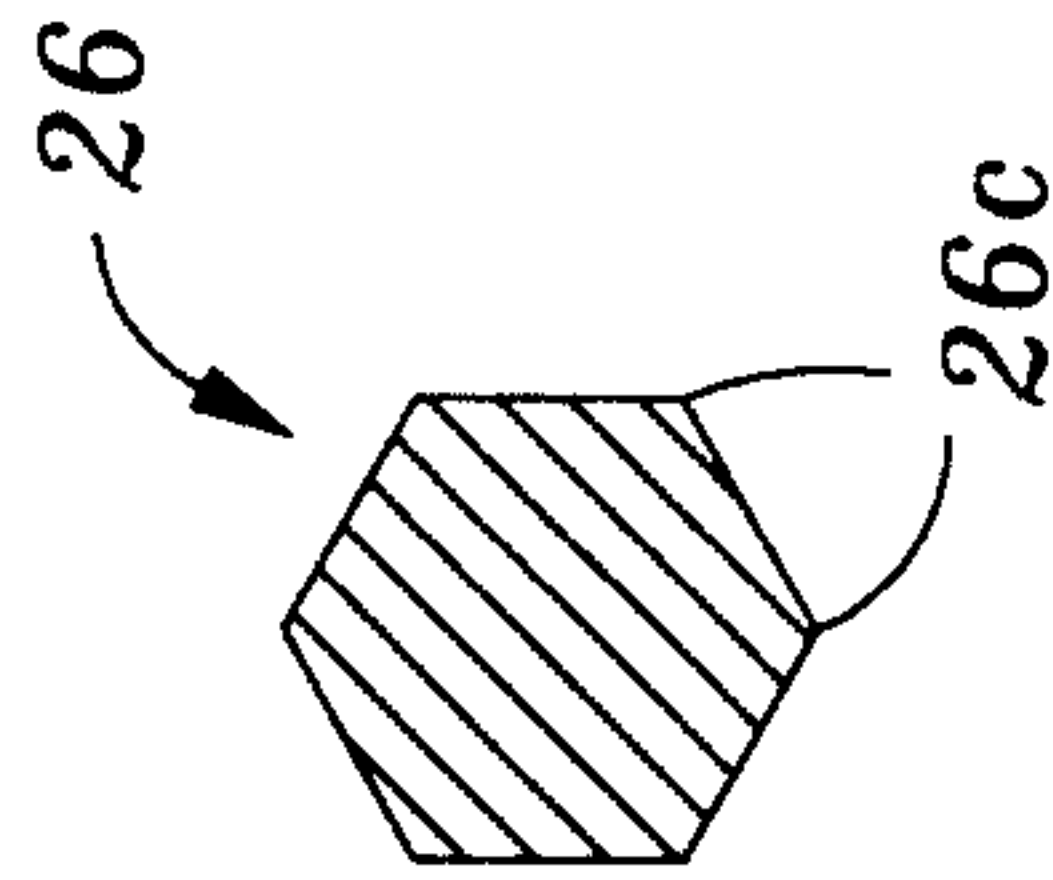
*Fig. 11*



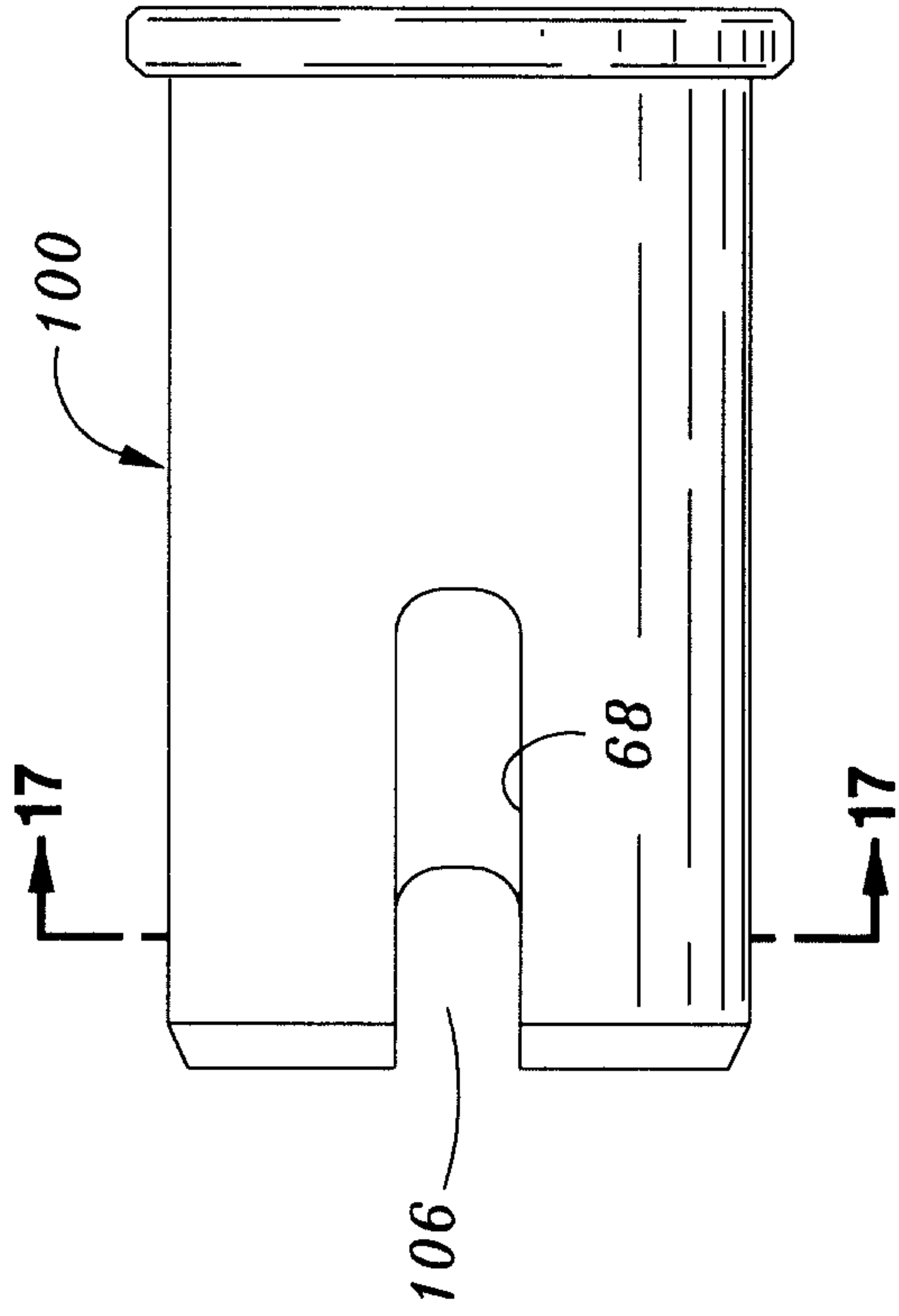
*Fig. 12*



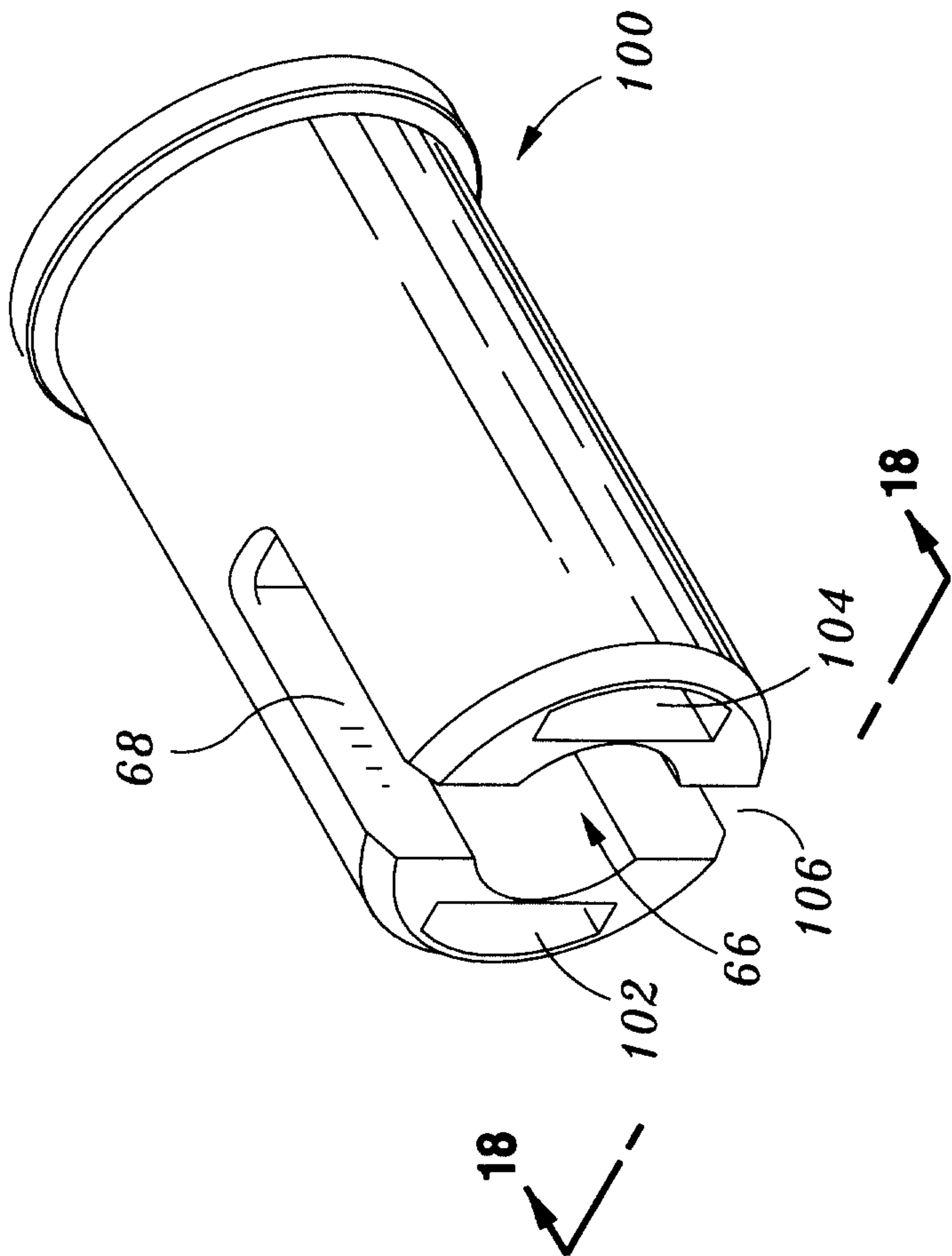
*Fig. 13*



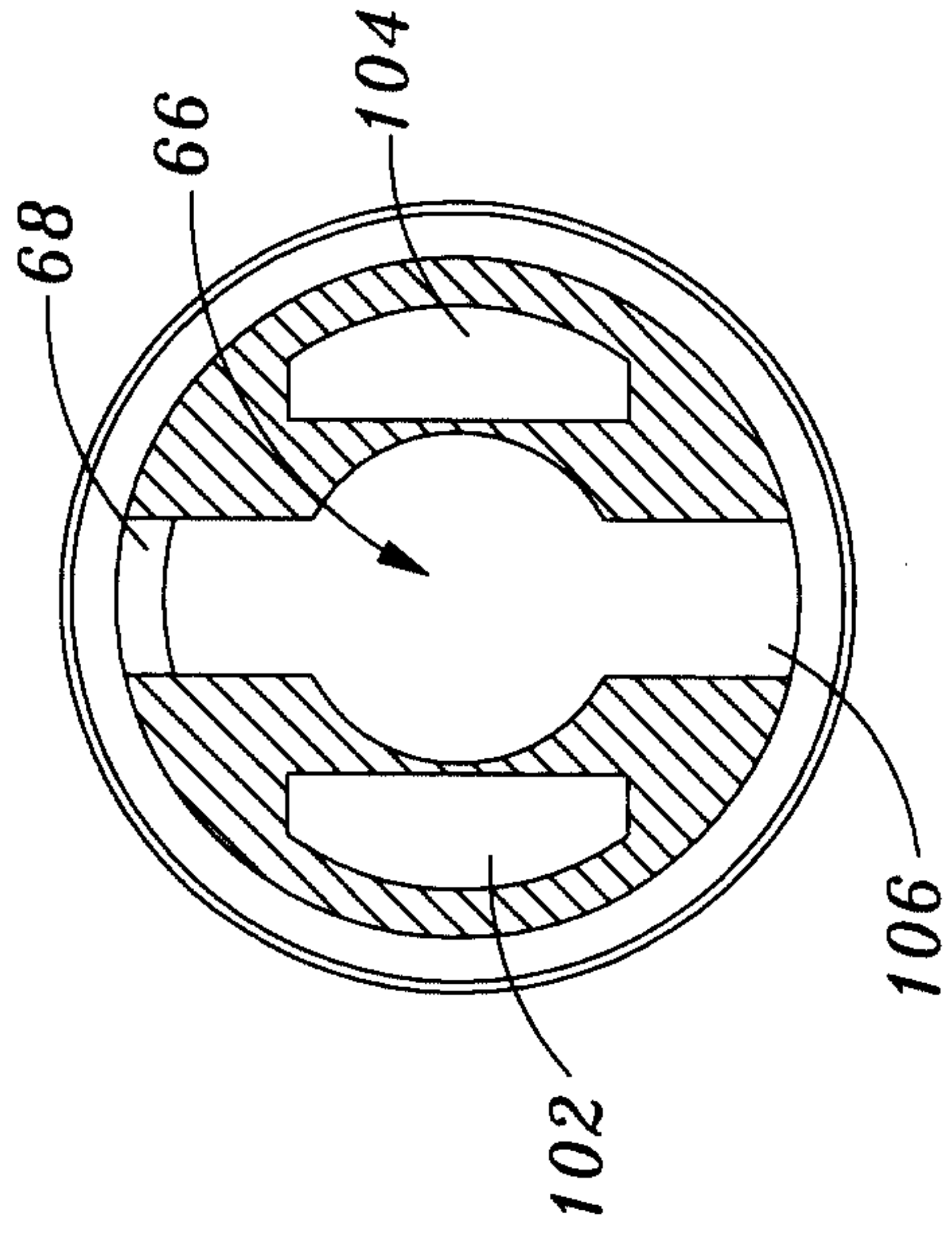
*Fig. 14*



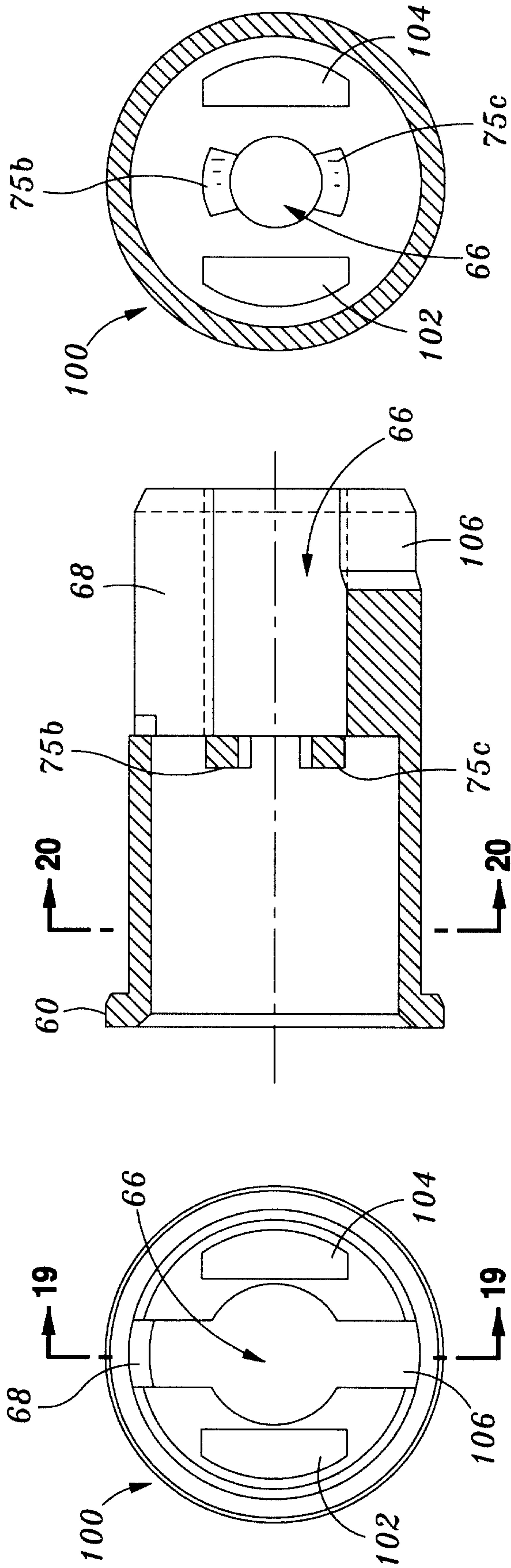
*Fig. 16*



*Fig. 15*



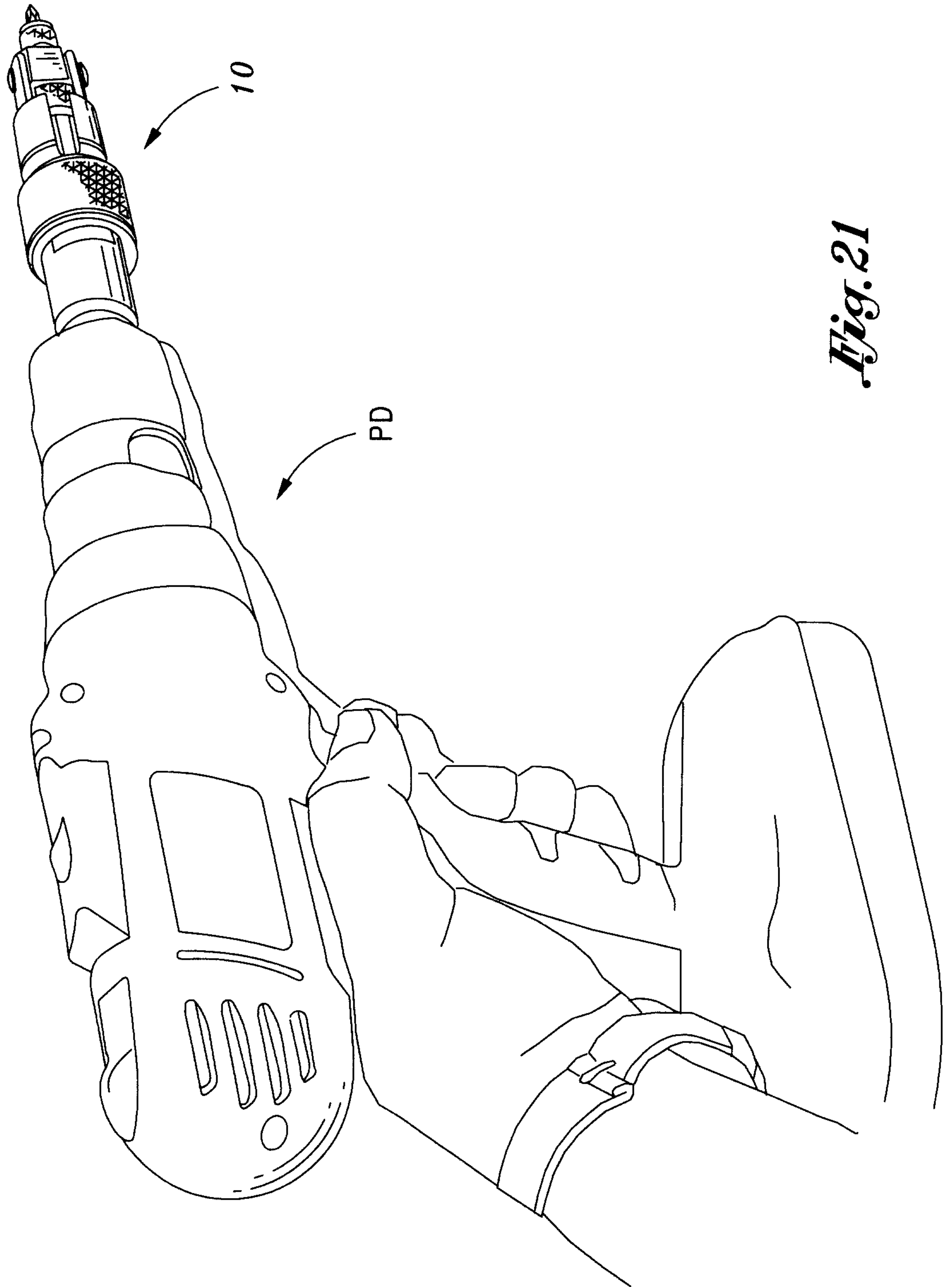
*Fig. 17*



*Fig. 18*

*Fig. 19*

*Fig. 20*



*Fig. 21*

