



## INTERNATIONAL APPLICATION PUBLISHED UNDER THE PATENT COOPERATION TREATY (PCT)

<p>(51) International Patent Classification <sup>6</sup> : <b>A61F 2/06, 2/04</b></p>	<p><b>A1</b></p>	<p>(11) International Publication Number: <b>WO 96/41589</b></p> <p>(43) International Publication Date: 27 December 1996 (27.12.96)</p>
<p>(21) International Application Number: PCT/DK96/00254</p> <p>(22) International Filing Date: 11 June 1996 (11.06.96)</p> <p>(30) Priority Data: 95109746 13 June 1995 (13.06.95) RU</p> <p>(71) Applicant (for all designated States except US): WILLIAM COOK EUROPE A/S [DK/DK]; Sandet 6, DK-4632 Bjæverskov (DK).</p> <p>(72) Inventors; and (75) Inventors/Applicants (for US only): KAVTELADZE, Zaza Alexandrovich [RU/RU]; ul. Mosfilmovskaya, 11-2-33, Moscow, 117330 (RU). KORSHOK, Alexandr Pavlovich [RU/RU]; Lyuberetsky raion, pos. ul. kv. 30, Moskovskaya obl., 140070 (RU).</p> <p>(74) Agents: INDAHL, Peter et al.; Internationalt Patent-Bureau, Høje Taastrup Boulevard 23, DK-2630 Taastrup (DK).</p>		<p>(81) Designated States: AL, AM, AT, AU, AZ, BB, BG, BR, BY, CA, CH, CN, CZ, DE, DK, EE, ES, FI, GB, GE, HU, IL, IS, JP, KE, KG, KP, KR, KZ, LK, LR, LS, LT, LU, LV, MD, MG, MK, MN, MW, MX, NO, NZ, PL, PT, RO, RU, SD, SE, SG, SI, SK, TJ, TM, TR, TT, UA, UG, US, UZ, VN, ARIPO patent (KE, LS, MW, SD, SZ, UG), Eurasian patent (AM, AZ, BY, KG, KZ, MD, RU, TJ, TM), European patent (AT, BE, CH, DE, DK, ES, FI, FR, GB, GR, IE, IT, LU, MC, NL, PT, SE), OAPI patent (BF, BJ, CF, CG, CI, CM, GA, GN, ML, MR, NE, SN, TD, TG).</p> <p><b>Published</b> With international search report. Before the expiration of the time limit for amending the claims and to be republished in the event of the receipt of amendments.</p>
<p>(54) Title: A DEVICE FOR IMPLANTATION IN A VESSEL OR HOLLOW ORGAN LUMEN</p>		
<p>(57) Abstract</p> <p>A device for implantation in a vessel or hollow organ lumen in a human or animal body, such as a self-expanding stent, a cava filter, an embolizing means or a supporting means, comprises a wire frame with a plurality of interconnected cells made of at least two separate wire sections which are intercrossing at cell junctions and form closed cells. At the cell junctions the wires are knot to form a geometrical locking of the cells so that the wire-shaped cell sides in respective cells are locked at the cell junctions when the wire frame is subjected to pressure acting radially inwards.</p> <div data-bbox="726 1220 1420 1747" style="text-align: right;"> </div>		

**FOR THE PURPOSES OF INFORMATION ONLY**

Codes used to identify States party to the PCT on the front pages of pamphlets publishing international applications under the PCT.

AM	Armenia	GB	United Kingdom	MW	Malawi
AT	Austria	GE	Georgia	MX	Mexico
AU	Australia	GN	Guinea	NE	Niger
BB	Barbados	GR	Greece	NL	Netherlands
BE	Belgium	HU	Hungary	NO	Norway
BF	Burkina Faso	IE	Ireland	NZ	New Zealand
BG	Bulgaria	IT	Italy	PL	Poland
BJ	Benin	JP	Japan	PT	Portugal
BR	Brazil	KE	Kenya	RO	Romania
BY	Belarus	KG	Kyrgystan	RU	Russian Federation
CA	Canada	KP	Democratic People's Republic of Korea	SD	Sudan
CF	Central African Republic	KR	Republic of Korea	SE	Sweden
CG	Congo	KZ	Kazakhstan	SG	Singapore
CH	Switzerland	LI	Liechtenstein	SI	Slovenia
CI	Côte d'Ivoire	LK	Sri Lanka	SK	Slovakia
CM	Cameroon	LR	Liberia	SN	Senegal
CN	China	LT	Lithuania	SZ	Swaziland
CS	Czechoslovakia	LU	Luxembourg	TD	Chad
CZ	Czech Republic	LV	Larvia	TG	Togo
DE	Germany	MC	Monaco	TJ	Tajikistan
DK	Denmark	MD	Republic of Moldova	TT	Trinidad and Tobago
EE	Estonia	MG	Madagascar	UA	Ukraine
ES	Spain	ML	Mali	UG	Uganda
FI	Finland	MN	Mongolia	US	United States of America
FR	France	MR	Mauritania	UZ	Uzbekistan
GA	Gabon			VN	Viet Nam

A device for implantation in a vessel or hollow organ lumen.

The invention relates to a device for implantation in a vessel or hollow organ lumen in a human or animal body, such as a self-expanding stent, a cava filter, an embolizing means or a supporting means, the device comprising a wire frame with a plurality of interconnected cells made of at least two separate wire sections which are intercrossing at cell junctions and form closed cells.

Medical implantation devices to which the invention pertains have found wide-spread use in percutaneous vascular and cardiac surgery and comprise in particular stents, intravenous filter devices for the capture of thrombi in major veins such as the lower caval vein and occlusion devices for permanent or temporary obturation of a vessel lumen or permanent occlusion of defects in vascular walls such as an ASD in the atrial septum, a PDA defect or other defects in vascular walls such as the inlet of an exfoliative aneurism of the aorta or a puncture hole in connection with angiographic investigation.

A stent is a device that can be placed within the lumen, or interior space, of a tubular structure for supporting and assuring patency of a lumen, viz. reopening of or keeping the lumen open. Stents are used, for example, for holding blood vessels open or for back tacking intimal flaps inside vessels after angioplasty. More generally, however, stents can be used inside the lumina of any physiological conduit including arteries, veins, vessels, the biliary tree, the urinary tract, the alimentary tract, the tracheobronchial tree, the genitourinary system, and the cerebral aqueduct.

The above mentioned device in the form of a self-expanding stent is known from WO94/03127 where the cells have a mainly square shape in a developed view. The wire sections are twisted one turn about each other about a twist axis extending in the longitudinal direction of the tubular frame body. When a stent with such cell junctions is subjected to a radial inwards pressure in a local area the cell junctions act as hinge joints allowing the cells in the pressure affected area to collapse at a relatively low pressure loading. This drawback may disqualify use of the stent in a body vessel positioned in vicinity of rigid structures such as a bone, because the pressure from such structure may cause a significant reduction of the vessel lumen due to collapsed cells.

A number of other implantation devices are known. EP-B-0 221 570 describes an expandable graft having a frame body made of a plurality of wires extending helically in opposite directions through the body. The wires may in one embodiment be woven in a criss-crossed pattern, but this does not provide cells of well-defined size or shape, because the wires may easily slide at the wire intersections. In another embodiment this is prevented by fixing the wires at the intersections by soldering, welding, or gluing. Such fixing involves the rather serious drawback that the resulting device comprises additional substances which may cause tissue reactions. A similar drawback is present in the vascular stents known from e.g. US-A-5 370 683, and EP-A-0 556 850 where the wire sections are joined by a ring of suture material at the cell junctions. In addition this latter embodiment is very time-consuming to manufacture.

EP-A-0 622 088 shows coupling of two or more Z-shaped stents in an end-to-end configuration by providing the stents with eyes at the stent ends, hooking the

eyes into one another and closing the eyes by soldering, which also introduces additional substances.

An object of the present invention is to provide a device for implantation having cells which are rigidly  
5 interlocked and have a relatively large rigidity to local radial compression without requiring use of additional substances for locking the wires at the cell junctions.

With a view to this the device according to the  
10 invention is characterized in that at the cell junctions the wires are knot to form a geometrical locking of the cells so that the wire-shaped cell sides in respective cells are locked at the cell junctions when the wire frame is subjected to pressure acting radially inwards.

15 The knot wires at the cell junctions provide the desired locking by using only wire material so that the previously used solder, glue or suture may be dispensed with. This greatly improves the biological compatibility of the device and reduces risks of undesirable tissue  
20 reactions. The locking of the cell sides at the cell junctions make the individual cell a rigidly closed functional element which largely maintains its stiffness to radial compression in a local area because the geometrical locking prevents deflection of a cell side  
25 in being transferred to the subsequent cells in the longitudinal direction of the frame. When compared to the first mentioned prior art stent, the geometrical locking naturally raises the stress level in wire material constituting the individual cell sides, however  
30 the stress levels will not be higher than in the prior art stents with soldered junctions and comparable wire dimensions. It is also an advantage that the wire sections due to the knot cell junctions extend through the surface of the frame in a certain pattern, which  
35 depends on the chosen type of knots or combination of

knots in the frame, because the continuous run of the wire sections provide the frame with a more even distribution or variation of stiffnesses than obtainable with several frame portions joined by sutures or other  
5 rings. In many applications such slow variation of the frame properties is advantageous in order to avoid or reduce vessel trauma or damage, in particular if the device is intended for long-term positioning in a vessel.

10 In a preferred embodiment the wire frame, in a developed view, includes rhomboid cells each having four cell sides and four cell junctions positioned at the apexes of the cell. The rhomboid cell shape is particularly advantageous in that the tubular frame obtains a  
15 comparatively large radial stiffness in relation to the amount of wire material used, which during introduction of the frame in a radially compressed state promotes usage of a small diameter of the introducer sheath, allowing true percutaneous techniques with a sheath with  
20 an outer measure of 14 or 16 French. Very varied frame shapes with irregular geometries, such as tubular portions combined with cone-shaped portions may be built with rhomboid cells. A high rigidity is obtained by the geometrical locking of each cell at the four junctions,  
25 and due to the fact that the geometrically locked junctions are produced at the twining of the wire sections into the frame with knots, supplementary manufacturing steps are avoided which is favourable when the frame has a complicated geometry.

30 In another embodiment the wire frame, in a developed view, includes square cells each having four cell sides and four cell junctions. The square cells may be useful in frame sections having an even diameter, and they provide the frame with a large radial stiffness.

In a further embodiment the wire frame, in a developed view, includes polygonal cells each having more than four cell sides and a corresponding number of cell junctions. Such cells may, as an example be useful  
5 in cone-shaped surfaces or in areas providing transition between two regularly shaped frame sections or in areas where the type of cells are changing. Other cell shapes, such as triangular or circular are also possible.

With respect to the knot types it is for many of  
10 the frame geometries preferred that the wire frame includes cell junctions where two wire sections are loop-shaped, and that the two cell sides carrying the loop on one of the wire sections pass through the loop of the other wire section and vice versa, whereby said  
15 junctions preferably are square knot-like. This type of knot provides secure locking and are particularly useful in connection with rhomboid or diamond shaped cells because the knot returns the wire section to the same side as it approached the knot leading to a zigzagging  
20 run of each wire section along the length of the wire frame. The embodiment may apart from square knot (reef-knot) types also be used to make the less preferred granny knot types of knot.

Another embodiment includes a knot specially  
25 designed to lock a cell side of adjustable length between a pair of cell junctions. In this embodiment the wire frame includes pairs of cell junctions where the one wire section is looped once over and under the other wire section, and vice versa at each cell junction, and  
30 between the two junctions in a pair the two wire sections are twisted at least one turn about each other. In this type of knot the wire section exits to the same side of the pair of cell junctions as it approached the same leading to a kind of wavy run of each wire section.

In some types of wire frames it is desired to have each wire section run in a stepped helical configuration through a frame portion or it is desired to shift a zigzagging or a wavy run of a wire through one row of  
5 cells to a run through another row of cells. For that purpose the wire frame may include cell junctions where two wire sections are twisted one turn about each other about a twist axis extending in a first direction and at least one turn about each other about a second twist  
10 axis extending at an angle, preferably at approximately  $90^\circ$  to said first direction. This type of knot further provides secure locking of the two wire sections in two mutually angled directions which results in a geometrically very stable cell junction. If the cell junction  
15 is at a position of changing frame geometry said angle may e.g. be  $20^\circ$ ,  $30^\circ$ ,  $45^\circ$  or  $60^\circ$ , but for many applications an angle in the range of  $85-95^\circ$  would be preferable.

The latter embodiment may preferably be tailored  
20 for stents in that the wire frame includes a tubular portion with a mainly even diameter, and that said first direction extends approximately in the circumferential direction of said tubular portion and said second twist axis extends approximately in the longitudinal direction  
25 of said tubular portion.

In another embodiment the wire frame having rhomboid cells includes a tubular portion with cell junctions where two wire sections are twisted at least one turn about each other about a twist axis extending  
30 approximately in the circumferential direction of said tubular portion. These junctions are useable in connection with cells of rhomboid shape. The circumferential extent of the twist axis prevents the cells from opening under radial load.



Examples of embodiments according to the invention will be described in further detail in the following with reference to the very schematic drawings, on which

Fig. 1a shows a first type of a knot at a cell  
5 junction in a wire frame of a device according to the invention,

Figs. 1b and 1c show in a developed view a section of a frame wall in an embodiment with rhomboid cells and part of a stent having such a frame wall, respectively,

10 Fig. 2a shows a second type of a knot at a pair of cell junctions in a wire frame of a device according to the invention,

Figs. 2b, 2c and 2d show in a developed view a section of two different frame walls in embodiments with  
15 square cells and polygonal cells and part of a stent having a frame wall of the type shown in Fig. 2b, respectively,

Fig. 3a shows a third type of a knot at a cell  
junction in a wire frame of a device according to the  
20 invention,

Figs. 3b and 3c show in a developed view a section of a frame wall in an embodiment with rhomboid cells and part of a stent having such a frame wall of the type shown in Fig. 3b, respectively,

25 Fig. 4 shows a fourth type of a knot at a cell junction in a wire frame of a device according to the invention, and

Figs. 5a-5e, 6a-6e and 7a-7c different embodiments of devices according to the invention.

30 In Figs. 1b and 1c is shown part of a wire frame generally designated 1. The wire frame is made of several wire sections or filament sections which on a mandril are bent and knot into the desired frame shape. The mandril includes in a well known manner a plurality  
35 of guide pins positioned on the mandril in dependency

of the desired shape of the cells in the frame. In Fig. 1b is shown the first guide pin 2 for a row of cells 3 extending in the longitudinal direction of the frame 1. The two wire sections 4, 5 used for the row of cells 5 preferably consists of a single length of wire which is looped around the first guide pin 2 so that the two sections extend from the pin. The run of one of the wire sections in a zigzagging course in the longitudinal direction A of the frame is in Fig. 1b indicated by a 10 broken line following said wire section 4. Similar lengths of wire or filament is looped around similar first guide pins, not shown, pertaining to the other longitudinal rows of cells in the wire frame to be manufactured. At cell junctions 6 marked by black dots 15 in the figures the two wire sections extending to the junction are manipulated to form the knot of the desired type and then bend towards their respective next junction. The cells are preferably made one circumferential row after the other by bending successive 20 pairs of wire sections towards the next cell junction, making the knot and repeating these steps with the circumferentially next pairs of wire sections until a complete circumferential row of cells has been made, and the next circumferential row of cells is made in a similar manner etcetera, until the wire frame is completed. 25

The first type of knot shown in Fig. 1a is a square or reef-knot 7 which may be made by twisting the two wire sections 4, 5 one turn around each other, reversing the direction of the wire sections and passing one of 30 the wire sections around the other so that the double loop configuration is made. This type of knot has been used in the cell pattern shown in Figs. 1b and 1c, and it is well suited and preferred for cells of diamond shape. It appears that each rhomboid or diamond shaped

cell includes four cell sides 8 and four cell junctions 6.

The wire or filament material used for the various wire frames in the devices according to the invention 5 is preferably nitinol, which has excellent elastic properties and can tolerate large deformations. Alternatively, stainless steel, titanium, copper alloys, tantalum or other biologically compatible materials capable of maintaining the expanded state inside the 10 vessel, or mixtures of such materials may be used. If the device is a stent to be balloon-expanded at the positioning in the vessel, stainless steel may be just as suitable as nitinol. It is also possible to use a synthetic material as the wire material, such as 15 modified butadiene or another synthetic material with good resilient properties.

The cross-sectional area of the cell sides is chosen on the basis of the desired frame size, desired rigidity and the cell shape in the frame, a larger 20 cross-sectional area being used at larger diameters, at a larger desired rigidity and/or at more open cells or lower cell number.

The tubular wire frame portions shown in Figs. 1c, 2d and 3c may be used for stents or for the even 25 diameter sections of the wire frames shown in Figs. 7a and 7b.

When the wire frame is a stent for use in the Iliac, the stent may, for example, have a diameter of 8 mm, there may be four cells in each annular row, and 30 the filament may, for example, be a nitinol wire with a diameter of 0.16 mm. A corresponding stent can be used in bile ducts, the lumen of which is reduced by tumours or fibrosis. Stents may also be used for expanding the oesophagus in patients suffering from malignant 35 dysphagia, for expanding the urinary tracts or other

body vessels. A very important field of application is stents for expanding constrictions in blood vessels or for maintaining expanded vasoconstrictions, such as in hard stenoses. The below list mentions examples of 5 applicable stent diameters, etc., for different applications.

	<u>Field of application</u>	<u>Stent diameter</u>
	Arteries	
10	Coronary	2-4 mm
	Iliac	6-12 mm
	Femoral	6-12 mm
	Renal	6-12 mm
	Carotid	6-12 mm
15	Aortic aneurism	15-30 mm
	Veins	
	Vena cava	12-30 mm
	Vena subclavia	12-30 mm
	Arteriovenous shunt endoprosthesis	6-14 mm
20	TIPS (by-pass in liver)	10-12 mm
	Urology	
	Uretal	4-7 mm
	Urethral	4-7 mm
	Gastro-enterology	
25	Oesophageal	18 mm at the middle
	Biliary	6-10 mm
	Pancreatic	2-3 mm
	Thorax	
	Bronchial	15-20 mm
30		

The filament or wire diameter is adapted to the stent diameter, the cell sides being given less cross-sectional area at smaller stent diameters. The wire diameter may, for example, be in the interval of 0.06-35 0.40 mm.

It is possible to supplement the wire frame with a sheath of a suitably material, such as dacron, PTFE or another biocompatible material. The use of such a graft on a wire frame is well-known in the art and needs  
5 no further description.

A second type of knot 10 is seen in Fig. 2a. For the sake of simplicity the separate wire sections are in the following designated with 4, 5 as in Fig. 1 and likewise the cell junctions are all designated with 6.  
10 In the various frame embodiments the cells are designated with separate numbers for separate cell configurations.

The knot 10 comprise two cell junctions 6, and at the one junction the two wire sections 4, 5 are passed  
15 one turn around each other and are bend to extend towards the other junction so that each wire section is looped once over and under the other wire section. Then the two wire sections are twisted at least one turn around each other, and at the other junction one of the  
20 wire sections is bent in the desired exit direction, which as shown may be approximately in parallel with its incoming direction to said one junction, and the other wire section is passed in a loop-shape one turn around the said one wire section to exit approximately in  
25 parallel with its own incoming direction to said one junction. The distance between the two junctions in a pair may be varied according to need, and if the distance is large the two wire sections may be twisted twice or thrice around each other between the two  
30 junctions.

The knot 10 may be used for cells 11 with a square configuration as shown in Figs. 2b and 2d or for cells 12 with a polygonal configuration, as indicated in Fig. 2c. The latter has a more dense frame structure, which  
35 may be preferred in applications where tissue ingrowth

is to be prevented. In frame areas where knot 10 is used each wire section has a wavy or omega-shaped run in the length direction of the frame, which has been indicated by a broken line in Figs. 2b and 2c. The resulting wire frame 1' depicted in Fig. 2d may have a more or less open structure in dependency of the chosen distance between each pair of cell junctions.

A third type of knot 20 shown in Fig. 3a is also applicable in connection with wire frames having rhomboid cells 3. At each cell junction 6 the two wire sections are twisted one turn around each other about a twist axis directed in the circumferential direction B of the tubular wire frame. Despite this simple type of winding the cells remain stable to radial compression because the cells are rhomboid and the twist axis is circumferentially directed. If required the wire sections may be twisted more than one turn about each other at each cell junction. The resulting configuration of the wire frame 1'' appears from Fig. 3c. With this type of knot each wire section obtains a stepped helical run through the wire frame section as indicated by the broken line in Fig. 3b.

A fourth type of knot 30 is seen in Fig. 4. At the cell junction the two wire sections 4, 5 are twisted one turn about each other about a twist axis 31 extending in a first direction and then the wire sections are bend in direction of a second twist axis 32 extending at an angle, preferably at approximately 90° to said first direction, and are twisted at least one turn about each other. This type of knot is particularly useful in respect of stents.

In the following further examples of devices according to the invention and having varied geometrical shapes are described.

An intravenous filter shown in fig. 5a comprises two coaxial interconnected bodies of revolution and each defined by wire sections forming cells 6 of a general rhombic shape over at least part of the surface of the body of revolution. The body of revolution may assume a more or less pronounced parabolic shape.

For the purpose of reliably fixing of the filter at a site of installation in a vein such as the lower caval vein anchoring members may be provided along the end rims 40 of the frame body 1''''.

As a special feature the filter may be provided with wire members 41 extending diametrically across the base of one or both of the bodies of revolution and being secured to one another at the centre of the base to function as extraction members engageable by a hook-shaped trapping wire introduced into the vein by means of a retraction catheter, not shown.

Due to the cellular surface of each of the bodies of revolution and the geometrical shape thereof as explained above the entire filter composed of the two bodies of revolution may be stretched in the direction of its axis and arranged in the distal end of a hollow radioopaque introduction catheter of a small external diameter, e.g 2.5 mm, which may be introduced percutaneously into the vascular system of a patient through a paracentetic puncture in a femoral or subclavian vein.

Such a small diameter introduction catheter will cause minimum traumatization of the walls of the vein through which the catheter with the filter is introduced.

At the desired site of implantation, such as in the lower caval vein, the filter is ejected from the introduction catheter by means of a pushing member slidably arranged inside the catheter and, by

dimensioning the diameter of the base of each of the bodies of revolution to be larger than the diameter of the vein or other vessel, reliable localization of the filter may be obtained also in case of temporary  
5 implantation where anchoring members are not used. For permanent installations an even more reliable localization may be obtained by means of said anchoring members.

In the illustrated embodiment of the filter with  
10 two slightly parabolic bodies of revolution one of these bodies will form an active filter part having its apex oriented downstream with respect to the blood flow whereby thrombotic masses will be collected at the apex and thus in the center of the lumen of the vein in which  
15 the filter is arranged. In the peripheral parts of the lumen a substantially free flow of blood will be ensured. Thereby, the risk of obturation of the vein lumen by thrombotic masses will be significantly reduced. The cells 6 are preferably geometrically locked  
20 at the cell junctions by means of knots 7 of the first type.

The filter may also be made of a single body of revolution of a general shape as outlined above.

In Fig. 6c another embodiment of the implantation  
25 device of the invention is illustrated which is intended to function as a vessel occlusion device. Also in this embodiment the device includes a wire frame 1'''' composed of two bodies of revolution 42, 43 each of which has a general shape as described above and is  
30 defined by wire sections forming substantially hexagonal cells 44 over at least a part of the surface of the body of revolution. The cells 44 are preferably geometrically locked at the cell junctions by means of knots 10 of the second type and/or knots 30 of the fourth type.



As described above for the filter embodiment of Fig. 5a the occluder embodiment in Fig. 6c may be easily arranged in the distal end of an introduction catheter, not shown, having a fairly small external diameter such as 2.5 mm and may be percutaneously introduced through the venous system or a puncture hole in a vessel segment. After introduction the occlusion device is ejected from the catheter and may completely obturate a vessel lumen due to an elastic membrane 45 which is reliably retained at the site of implantation by the self-expansion of the two bodies of revolution 42 and 43 assisted by the pressure gradient from the blood the flow of which is instantly blocked by the occlusion of the vessel.

Due to its flexibility and the general shape of the bodies of the revolution as well as the cellular surface made up of the wire sections the occlusion device is very flexible and suitable for introduction by means of an equally flexible conveying system whereby the risk of traumatization may be kept very low and the universality of the occlusion device for implantation in vessels of various diameters and geometry is ensured.

Instead of being joined together at their apices the two bodies of revolution may have their apices somewhat separated and displaceably connected by a flexible axially extending wire member to which the elastic blood impermeable membrane 45 is fixed. With this modification the occlusion device may be suitable for closing of a so-called ASD-defect i.e. a defect in the atrial septum between the right and left atria.

Fig. 6d shows a different embodiment of an occlusion device specially intended for curing the fatal condition known as Patent Ductus Arteriosus (PDA) caused by a duct or flow passage between the pulmonary arteria and the aorta. In this embodiment, the device comprises

only a single body of revolution 50 which as shown may be of a generally conical shape the apical end of which is connected through a flexible link of wire sections with the elastic blood impermeable membrane 51 which in this case may be supported on its external side by an umbrella-like wire frame structure 52. In this embodiment the cells of the wire frame are of mixed configurations, such as pentagonal cells and rhomboid cells.

10 Examples of other wire frame types using rhomboid cells and knots of the types e. g. 7 or 20 may be briefly mentioned. Fig. 5b shows a variant of the device in the form of a wire frame 60 having a double cone with connected bases. Fig. 5c shows a wire frame 61 shaped as a single truncated cone. Fig. 5d and 5e show wire frames 62, 63 including two truncated cones. Fig. 6a and 6b show wire frames 64, 65 with an impermeable membrane 66, 67 secured to its apex and base, respectively. Fig. 6e shows a wire frame 68 shaped as a double cone with connected bases and with an impermeable membrane 69 positioned between the bases. Fig. 7a shows a wire frame 70 shaped as a semi-bar bell. Fig. 7b shows a wire frame 71 shaped as a bar bell, and lastly Fig. 7c shows a wire frame 72 shaped as a hemisphere.

25 The various wire frames may as indicated above be placed inside a introducer catheter in a radially compressed state, either by being extended by an axial pull at both ends of the wire frame or by being subjected to a radial inwards directed pressure, e. g. by being pushed through a cone shaped loading sheet. When the device has been introduced to the desired lumen site, it is pushed or pulled out of the introducer catheter and due to the cell structure and the geometrical locking at the cell junctions the wire frame self-expands to approximately its initial shape.

30  
35

Whereas various embodiments of the implantable device of the invention have been described hereinbefore these examples and the medical applications associated therewith should not be considered exhaustive. The  
5 invention opens for a wide range of modifications and further developments of wire frame configurations and knot types in devices for treatment of a diversity of defects in the human vascular system within the scope of the following claims.

## P A T E N T   C L A I M S

1. A device for implantation in a vessel or hollow organ lumen in a human or animal body, such as a self-expanding stent, a cava filter, an embolizing means or  
5 a supporting means, the device comprising a wire frame with a plurality of interconnected cells made of at least two separate wire sections which are intercrossing at cell junctions and form closed cells, c h a r -  
a c t e r i z e d in that at the cell junctions the  
10 wires are knot to form a geometrical locking of the cells so that the wire-shaped cell sides in respective cells are locked at the cell junctions when the wire frame is subjected to pressure acting radially inwards.

2. A device according to claim 1, c h a r a c t -  
15 e r i z e d in that the wire frame, in a developed view, includes rhomboid cells each having four cell sides and four cell junctions positioned at the apexes of the cell.

3. A device according to claim 1, c h a r a c t -  
20 e r i z e d in that the wire frame, in a developed view, includes square cells each having four cell sides and four cell junctions.

4. A device according to claim 1, c h a r a c t -  
e r i z e d in that the wire frame, in a developed  
25 view, includes polygonal cells each having more that four cell sides and a corresponding number of cell junctions.

5. A device according to any one of claims 1 to  
4, c h a r a c t e r i z e d in that the wire frame  
30 includes cell junctions where two wire sections are loop-shaped, and that the two cell sides carrying the loop on one of the wire sections pass through the loop of the other wire section and vice versa whereby said junctions preferably are square knot-like.

6. A device according to any one of claims 1 to 5, characterized in that the wire frame includes pairs of cell junctions where the one wire section is looped once over and under the other wire section, and vice versa at each cell junction, and between the two junctions in a pair the two wire sections are twisted at least one turn about each other.

7. A device according to any one of claims 1 to 6, characterized in that the wire frame includes cell junctions where two wire sections are twisted one turn about each other about a twist axis extending in a first direction and at least one turn about each other about a second twist axis extending at an angle, preferably at approximately  $90^\circ$  to said first direction.

8. A device according to claim 7, characterized in that the wire frame includes a tubular portion with a mainly even diameter, and that said first direction extends approximately in the circumferential direction of said tubular portion and said second twist axis extends approximately in the longitudinal direction of said tubular portion.

9. A device according to claim 2, characterized in that the wire frame includes a tubular portion with cell junctions where two wire sections are twisted at least one turn about each other about a twist axis extending approximately in the circumferential direction of said tubular portion.

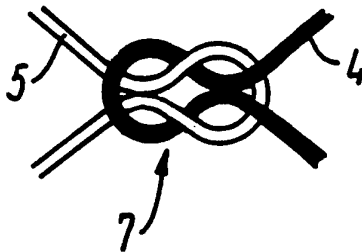

FIG. 1a

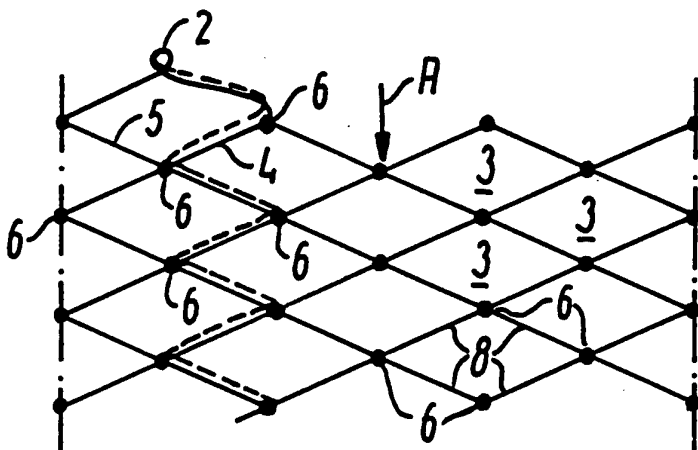

FIG. 1b

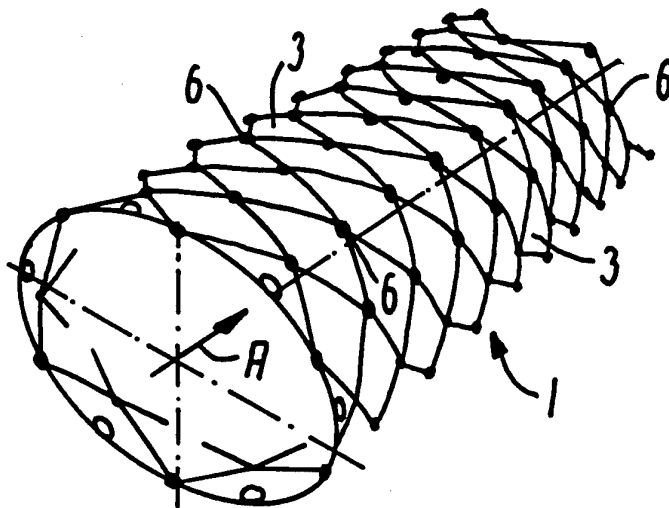

FIG. 1c

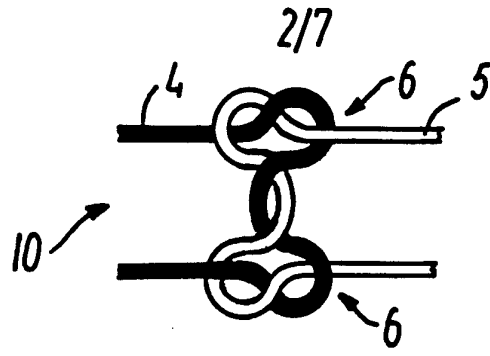

FIG. 2a

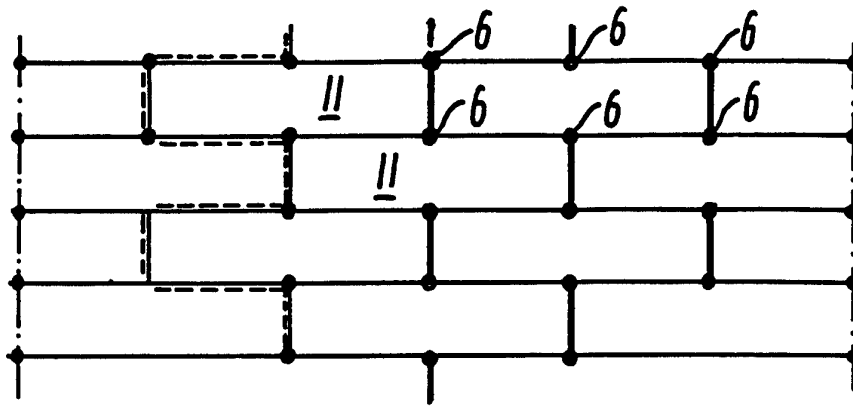

FIG. 2b

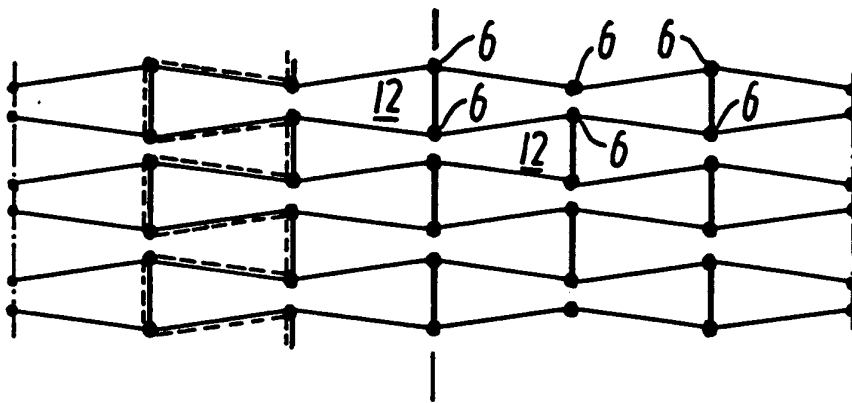

FIG. 2c

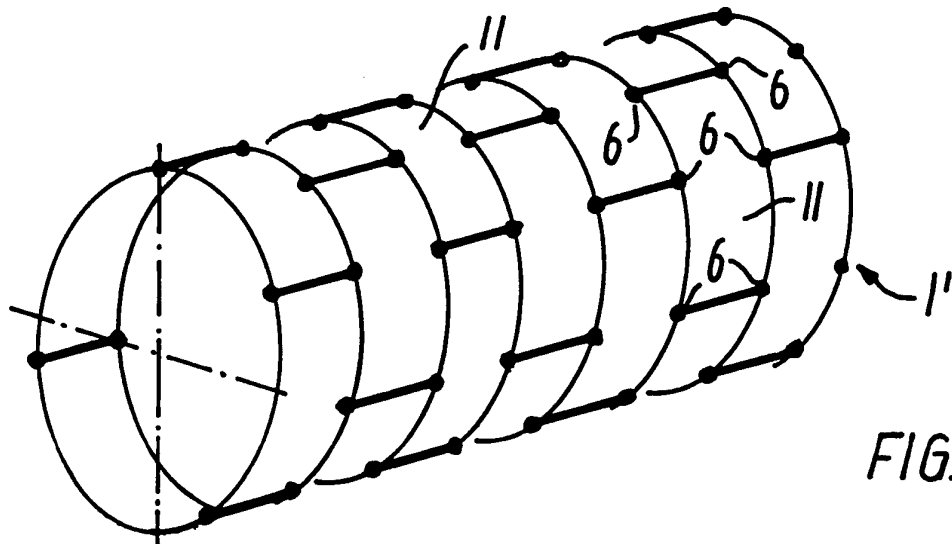

FIG. 2d

3/7

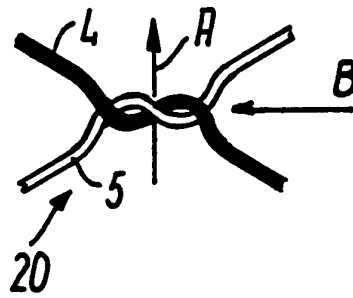

FIG. 3a

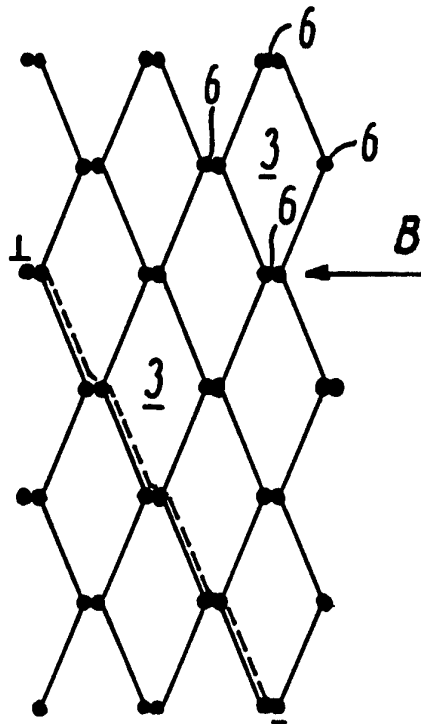

FIG. 3b

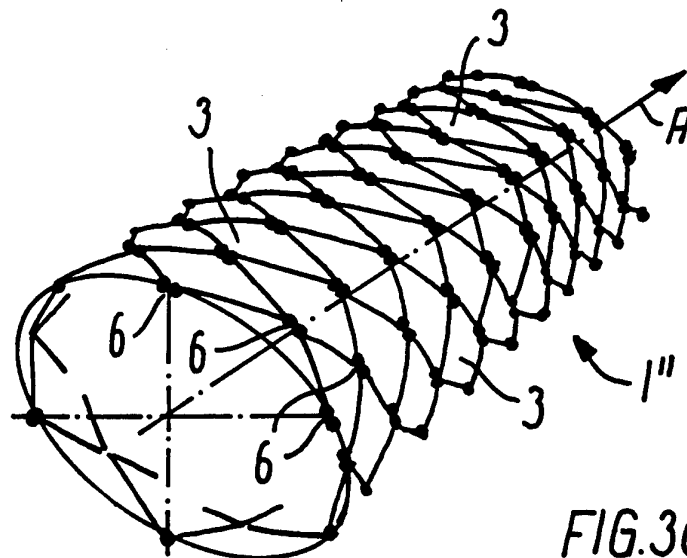

FIG. 3c



4/7

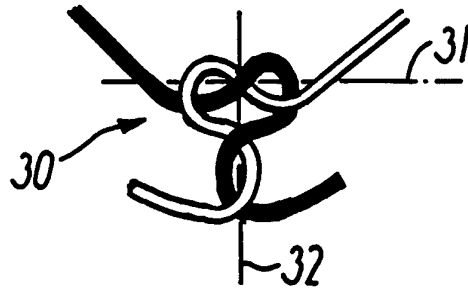

FIG. 4

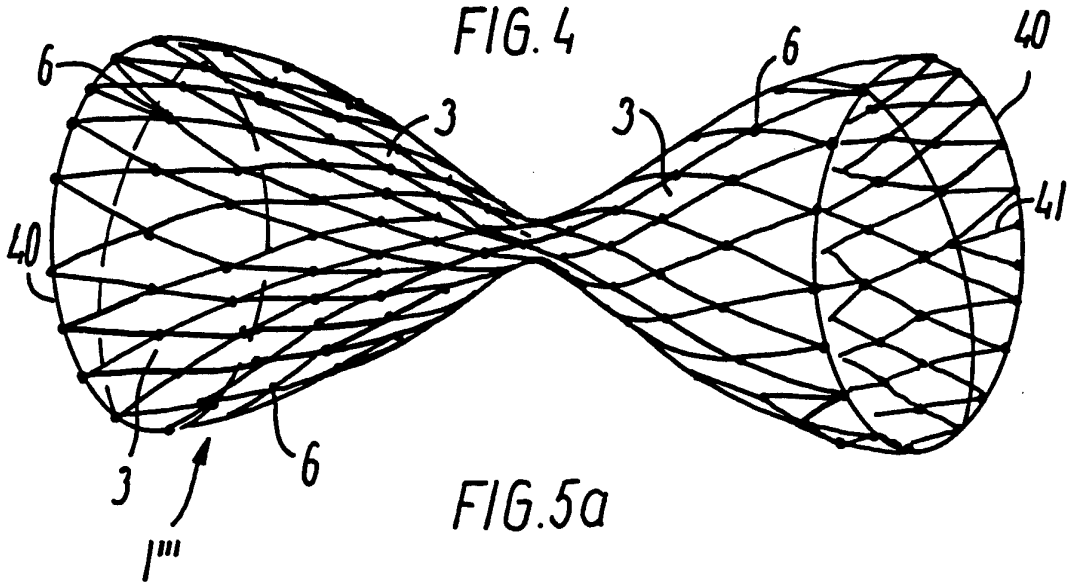

FIG. 5a

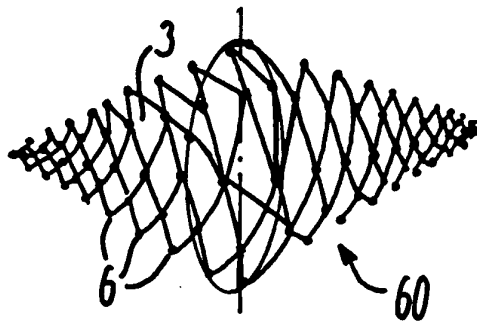

FIG. 5b

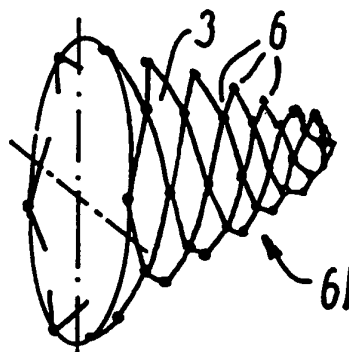

FIG. 5c

5/7

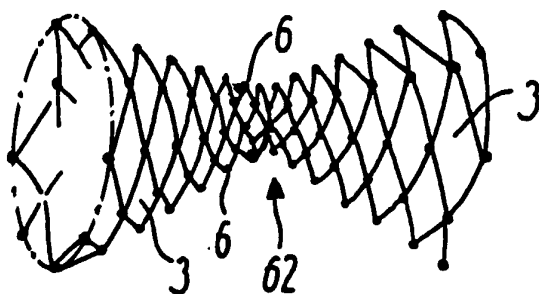

FIG. 5d

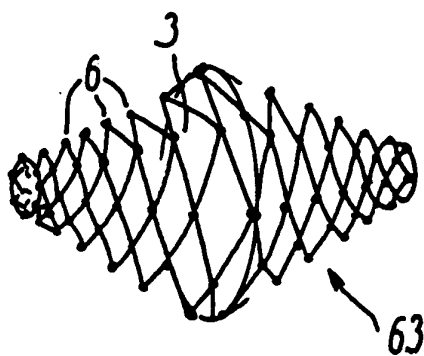

FIG. 5e

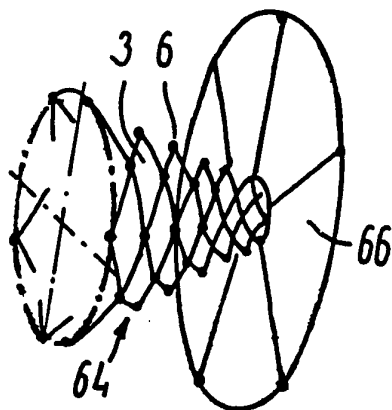

FIG. 6a

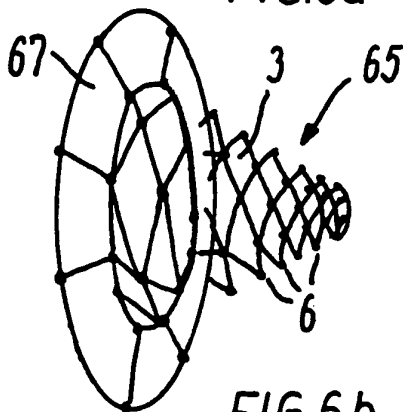

FIG. 6b

6/7

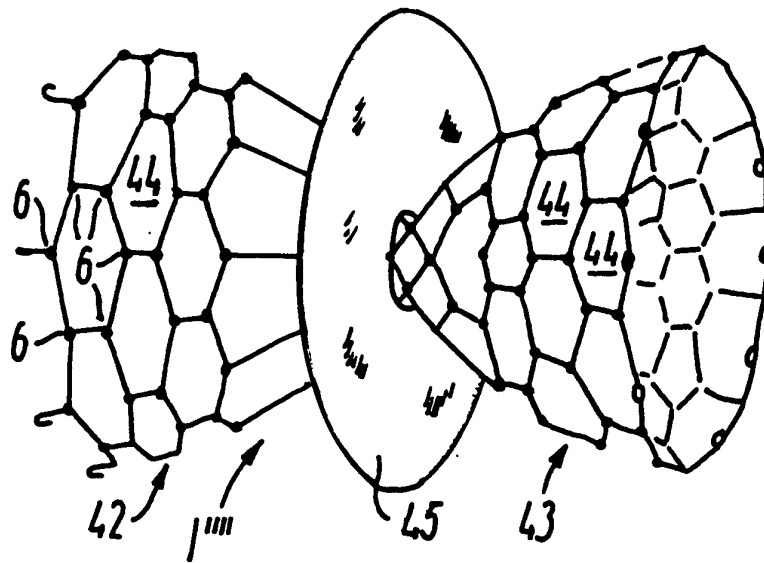

FIG. 6C

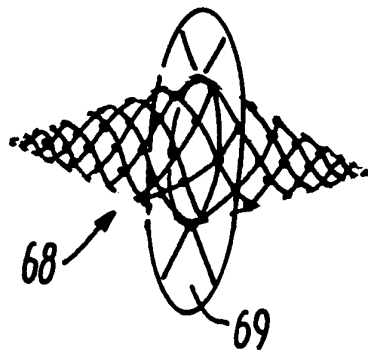

FIG. 6e

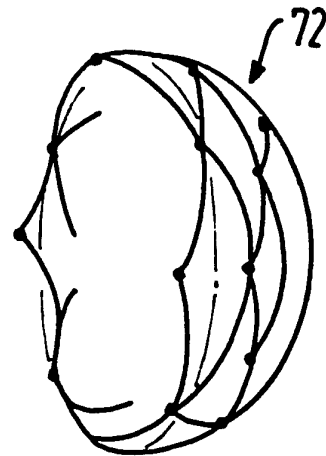

FIG. 7C

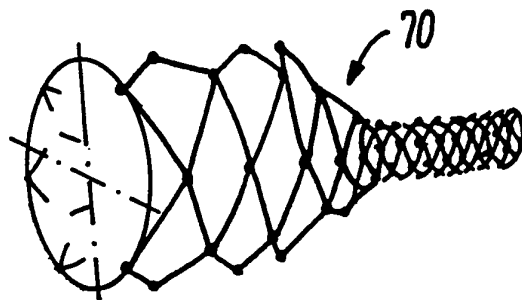

FIG. 7a

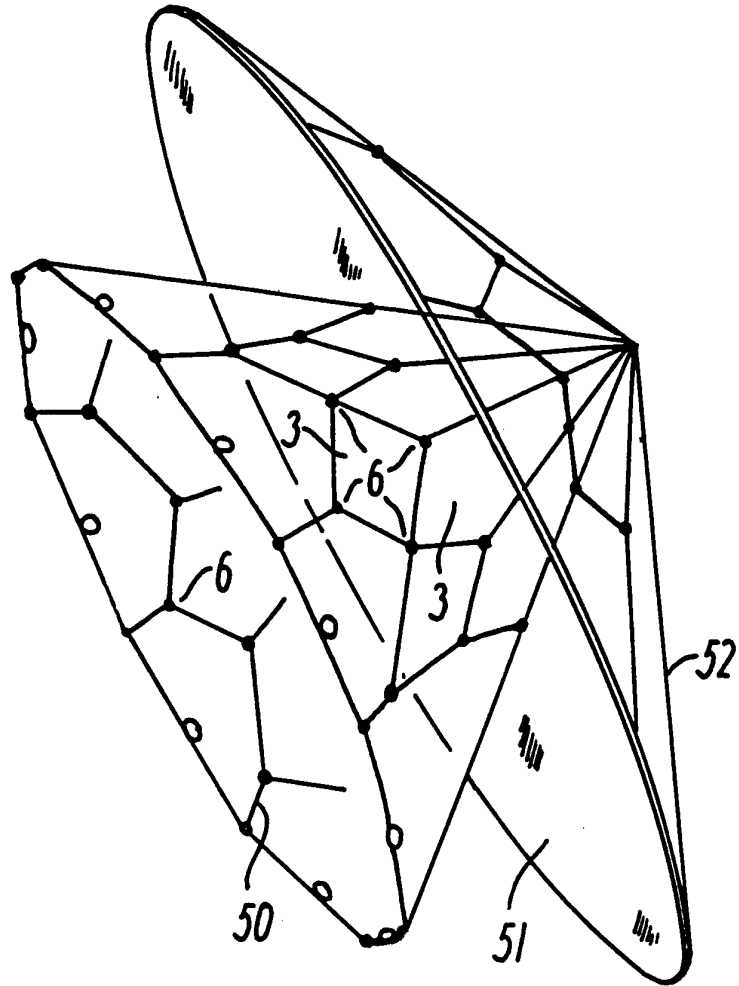

FIG. 6d

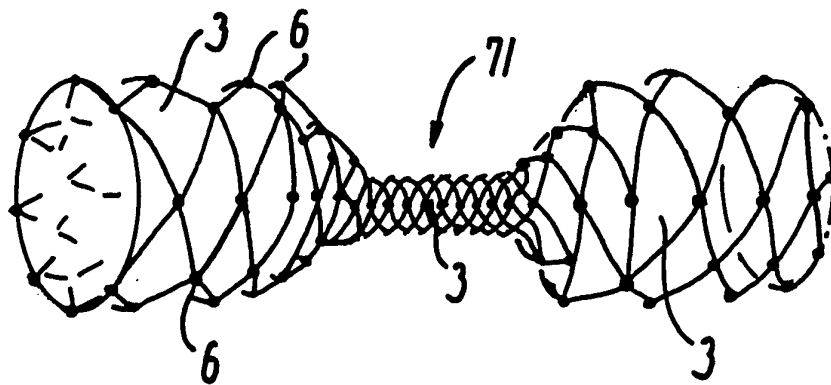

FIG. 7b

# INTERNATIONAL SEARCH REPORT

International application No.  
PCT/DK 96/00254

<b>A. CLASSIFICATION OF SUBJECT MATTER</b>				
IPC6: A61F 2/06, A61F 2/04 According to International Patent Classification (IPC) or to both national classification and IPC				
<b>B. FIELDS SEARCHED</b>				
Minimum documentation searched (classification system followed by classification symbols)				
IPC6: A61F				
Documentation searched other than minimum documentation to the extent that such documents are included in the fields searched				
SE,DK,FI,NO classes as above				
Electronic data base consulted during the international search (name of data base and, where practicable, search terms used)				
<b>C. DOCUMENTS CONSIDERED TO BE RELEVANT</b>				
Category*	Citation of document, with indication, where appropriate, of the relevant passages	Relevant to claim No.		
X	WO 9412136 A1 (BOSTON SCIENTIFIC CORPORATION), 9 June 1994 (09.06.94), page 2, line 20 - page 3, line 1 - line 6, figures 1b-1h, claim 51  --	1,3		
A	WO 9403127 A1 (WILLIAM COOK EUROPE A/S), 17 February 1994 (17.02.94)  --	1-9		
A	EP 0556850 A1 (ENDOTECH LTD.), 25 August 1993 (25.08.93)  -----	1-9		
<input type="checkbox"/> Further documents are listed in the continuation of Box C. <input checked="" type="checkbox"/> See patent family annex.				
<table style="width: 100%; border: none;"> <tr> <td style="width: 50%; border: none; vertical-align: top;">                     * Special categories of cited documents:                      "A" document defining the general state of the art which is not considered to be of particular relevance                      "B" earlier document but published on or after the international filing date                      "L" document which may throw doubts on priority claim(s) or which is cited to establish the publication date of another citation or other special reason (as specified)                      "O" document referring to an oral disclosure, use, exhibition or other means                      "P" document published prior to the international filing date but later than the priority date claimed                 </td> <td style="width: 50%; border: none; vertical-align: top;">                     "T" later document published after the international filing date or priority date and not in conflict with the application but cited to understand the principle or theory underlying the invention                      "X" document of particular relevance: the claimed invention cannot be considered novel or cannot be considered to involve an inventive step when the document is taken alone                      "Y" document of particular relevance: the claimed invention cannot be considered to involve an inventive step when the document is combined with one or more other such documents, such combination being obvious to a person skilled in the art                      "&amp;" document member of the same patent family                 </td> </tr> </table>			* Special categories of cited documents: "A" document defining the general state of the art which is not considered to be of particular relevance "B" earlier document but published on or after the international filing date "L" document which may throw doubts on priority claim(s) or which is cited to establish the publication date of another citation or other special reason (as specified) "O" document referring to an oral disclosure, use, exhibition or other means "P" document published prior to the international filing date but later than the priority date claimed	"T" later document published after the international filing date or priority date and not in conflict with the application but cited to understand the principle or theory underlying the invention "X" document of particular relevance: the claimed invention cannot be considered novel or cannot be considered to involve an inventive step when the document is taken alone "Y" document of particular relevance: the claimed invention cannot be considered to involve an inventive step when the document is combined with one or more other such documents, such combination being obvious to a person skilled in the art "&" document member of the same patent family
* Special categories of cited documents: "A" document defining the general state of the art which is not considered to be of particular relevance "B" earlier document but published on or after the international filing date "L" document which may throw doubts on priority claim(s) or which is cited to establish the publication date of another citation or other special reason (as specified) "O" document referring to an oral disclosure, use, exhibition or other means "P" document published prior to the international filing date but later than the priority date claimed	"T" later document published after the international filing date or priority date and not in conflict with the application but cited to understand the principle or theory underlying the invention "X" document of particular relevance: the claimed invention cannot be considered novel or cannot be considered to involve an inventive step when the document is taken alone "Y" document of particular relevance: the claimed invention cannot be considered to involve an inventive step when the document is combined with one or more other such documents, such combination being obvious to a person skilled in the art "&" document member of the same patent family			
Date of the actual completion of the international search		Date of mailing of the international search report		
31 October 1996		31 -10- 1996		
Name and mailing address of the ISA/ Swedish Patent Office Box 5055, S-102 42 STOCKHOLM Facsimile No. +46 8 666 02 86		Authorized officer  Dagmar Järvman Telephone No. +46 8 782 25 00		

**INTERNATIONAL SEARCH REPORT**  
Information on patent family members

01/10/96

International application No.  
PCT/DK 96/00254

Patent document cited in search report	Publication date	Patent family member(s)	Publication date
WO-A1- 9412136	09/06/94	EP-A- 0664689 JP-T- 8502428	02/08/95 19/03/96
WO-A1- 9403127	17/02/94	AU-A- 4698493 CA-A- 2141208 EP-A- 0653924 HU-A- 70815 HU-D- 9500345 JP-T- 7509633 PL-A- 307260	03/03/94 17/02/94 24/05/95 28/11/95 00/00/00 26/10/95 15/05/95
EP-A1- 0556850	25/08/93	US-A- 5405377	11/04/95