

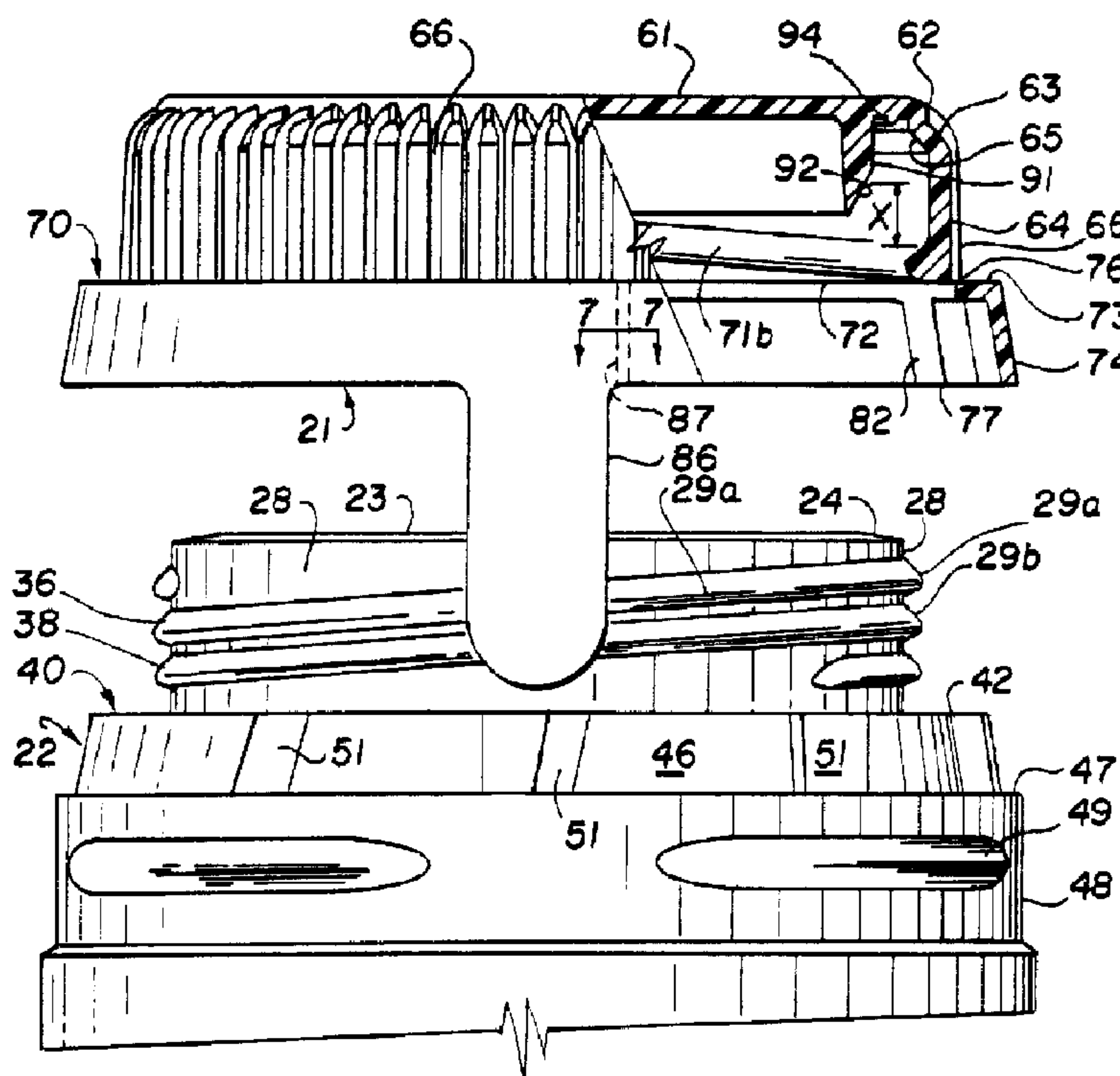

(86) Date de dépôt PCT/PCT Filing Date: 1992/10/06
 (87) Date publication PCT/PCT Publication Date: 1993/04/15
 (45) Date de délivrance/Issue Date: 2005/03/22
 (85) Entrée phase nationale/National Entry: 1994/04/08
 (86) N° demande PCT/PCT Application No.: US 1992/008493
 (87) N° publication PCT/PCT Publication No.: 1993/007070
 (30) Priorités/Priorities: 1991/10/08 (07/772,945) US;
 1992/01/31 (07/830,133) US

(51) Cl.Int.⁵/Int.Cl.⁵ B65D 41/34
 (72) Inventeurs/Inventors:
 LUCH, DANIEL, US;
 REPP, RICHARD E., US
 (73) Propriétaire/Owner:
 PORTOLA PACKAGING, INC., US
 (74) Agent: SMART & BIGGAR

(54) Titre : CAPSULE A ENCLIQUETER DEVISSABLE ET COL DE BOUTEILLE
 (54) Title: SNAP-ON, SCREW-OFF CAP AND CONTAINER NECK



(57) Abrégé/Abstract:

A tamper-evident, snap-on, screw-off closure (21) is used for a container neck (22) which has a first helical thread (29) on an upper neck stretch portion (28) and an external ratchet tooth (51) on a lower locking wall portion (40). The closure has an upper skirt (62) having helical thread (71) mating with the first helical thread. A downward extending skin (70) includes an outer skirt portion (74) which has an inwardly extending shoulder (73). A frangible section (76) interconnects the shoulder and the upper skirt portion (64). At least one vertical fin (100) is upstanding from the shoulder, preventing upward deformation of the lower skirt portion (74). The lower skirt portion (74) has at least one internal ratchet tooth (81) and a line of weakness (87) through the outer skirt portion and the shoulder. The lower portion skirt has a tear tab (86) which, when pulled, fractures the lower skirt at the frangible section (76).



INTERNATIONAL APPLICATION PUBLISHED UNDER THE PATENT COOPERATION TREATY (PCT)

<p>(51) International Patent Classification ⁵ : B65D 41/34</p>	<p>A1</p>	<p>(11) International Publication Number: WO 93/07070 (43) International Publication Date: 15 April 1993 (15.04.93)</p>
<p>(21) International Application Number: PCT/US92/08493 (22) International Filing Date: 6 October 1992 (06.10.92) (30) Priority data: 07/772,945 8 October 1991 (08.10.91) US 07/830,133 31 January 1992 (31.01.92) US (71) Applicant: CAP SNAP CO. [US/US]; 890 Faulstich Court, San Jose, CA 95112 (US). (72) Inventors: LUCH, Daniel ; REPP, Richard, E. : 890 Faulstich Court, San Jose, CA 95112 (US). (74) Agents: CAPLAN, Julian et al.; Flehr, Hohbach, Test, Albritton & Herbert, Four Embarcadero Center, Suite 3400, San Francisco, CA 94111-4187 (US).</p>		<p>(81) Designated States: AT, AU, BB, BG, BR, CA, CH, CS, DE, DK, ES, FI, GB, HU, JP, KP, KR, LK, LU, MG, MN, MW, NL, NO, PL, RO, RU, SD, SE, European patent (AT, BE, CH, DE, DK, ES, FR, GB, GR, IE, IT, LU, MC, NL, SE), OAPI patent (BF, BJ, CF, CG, CI, CM, GA, GN, ML, MR, SN, TD, TG). Published <i>With international search report.</i></p>

(54) Title: SNAP-ON, SCREW-OFF CAP AND CONTAINER NECK

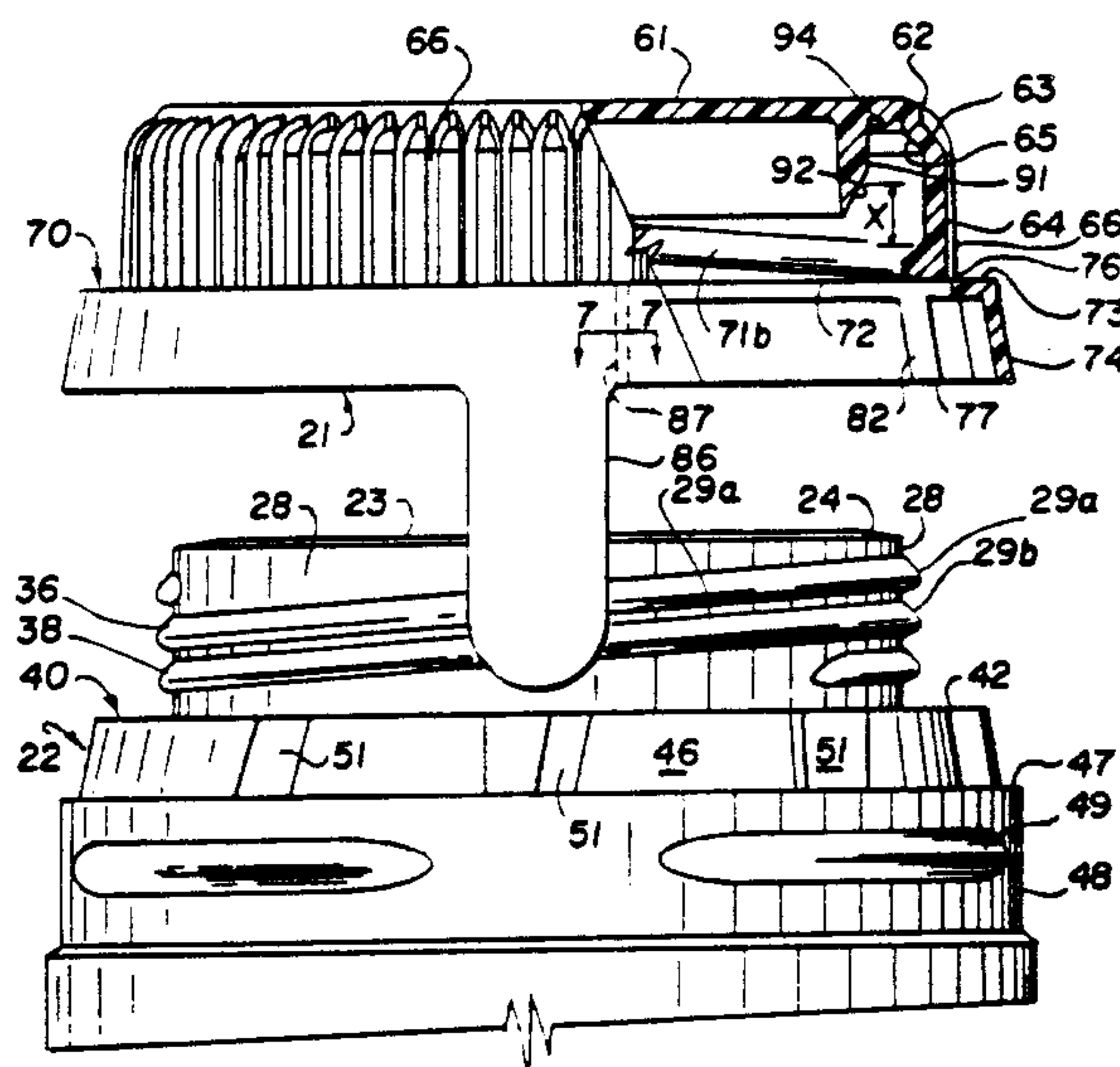

(57) Abstract

A tamper-evident, snap-on, screw-off closure (21) is used for a container neck (22) which has a first helical thread (29) on an upper neck stretch portion (28) and an external ratchet tooth (51) on a lower locking wall portion (40). The closure has an upper skirt (62) having helical thread (71) mating with the first helical thread. A downward extending skirt (70) includes an outer skirt portion (74) which has an inwardly extending shoulder (73). A frangible section (76) interconnects the shoulder and the upper skirt portion (64). At least one vertical fin (100) is upstanding from the shoulder, preventing upward deformation of the lower skirt portion (74). The lower skirt portion (74) has at least one internal ratchet tooth (81) and a line of weakness (87) through the outer skirt portion and the shoulder. The lower portion skirt has a tear tab (86) which, when pulled, fractures the lower skirt at the frangible section (76).

SNAP-ON, SCREW OFF CAP AND CONTAINER NECKBACKGROUND OF THE INVENTION1. Field of the Invention

The present invention relates in general to a tamper-
5 evident container closure and a container neck structure.
More particularly, the present invention relates to a
closure which is applied with an axial downward force onto
the neck. After the tamper-evident feature of the invention
is removed, the cap may be screwed onto and off the
10 container as a reclosure cap.

2. Description of the Related Art

The snap-on, screw-off structures available in the
prior art are of two general types--those having thread
engagement as initially applied, and those without initial
15 thread engagement. The no-thread initial engagement system
has the major advantages of being simple to manufacture and
apply, and achieving good re-seal on reclosure through the
thread torque. However, using a liner closure with this
system is somewhat difficult and the consumer may be
20 confused by the requirement of twisting the closure relative
to the neck after the container is initially opened by a
lifting motion. An example of a closure having no-thread
initial engagement is taught by U.S. Patent No. 4,561,553 to
Crisci.

25 A system having full thread engagement during the
initial application has several advantages over the no-
thread system, including the ability to easily use lined

61051-2644

2

closures and the elimination of consumer confusion. However, the initial thread engagement systems do not offer the manufacturing and application advantages available with the no-thread system. With the thread system, the closure
5 must be twisted relative to the container at some point during the application process. An example of such a closure is shown in U.S. Patent No. 4,625,875 to Carr.

The present invention provides full thread initial engagement by reason of a unique thread design, a unique
10 tamper-evident band and means of orienting the closure and container threads to achieve registration prior to straight axial application. The present invention offers considerable advantages over prior structures as is evident from the description of the related art and the following
15 description of the invention.

SUMMARY OF INVENTION

The present invention comprises an improved closure or cap and an improved neck finish. The cap skirt and neck are provided with mating threads of such shape that
20 the cap may be applied in a simple downward vertical movement, the cap skirt and neck flexing sufficiently to permit the threads to slip past each other.

According to one aspect the invention may be summarized as in combination, a container neck and a
25 container closure, said neck having an upper opening, a downward extending upper neck stretch portion below said opening, at least one first helical thread on an exterior surface of said upper neck stretch portion, a locking wall portion below said upper neck stretch portion, said locking
30 wall portion comprising a lower neck stretch portion offset

61051-2644

2a

outwardly relative to said upper neck stretch portion and a shoulder stretch portion interconnecting a lower edge of said upper neck stretch portion and an upper edge of said lower neck stretch portion, at least one external tooth on said locking wall portion, said closure having a top, a downward extending upper skirt portion depending from said top, at least one second helical thread on an interior surface of said upper skirt portion shaped to mate with said at least one first helical thread, a lower skirt portion below said upper skirt portion, said lower skirt portion comprising an outer skirt portion offset outwardly relative to said upper skirt portion and a shoulder extending inwardly from an upper edge of said outer skirt portion to a lower edge of said upper skirt portion, frangible means interconnecting said upper skirt portion and said shoulder, at least one internal tooth on said lower skirt portion shaped to engage said at least one external tooth to lock said closure relative to said neck until said frangible means are broken, said at least one first and second helical threads being shaped such that when said closure is moved directly axially downward on said neck without externally imposed relative rotation, said at least one first and second helical threads slip past each other allowing said container closure to engage said container neck.

25 According to another aspect the invention provides in combination, a container neck and a container closure, said neck having an upper opening, a downward extending upper neck stretch portion below said opening, at least one first helical thread on an exterior surface of said upper neck stretch portion, a locking wall portion below said upper neck stretch portion, said locking wall portion comprising a lower neck stretch portion offset outwardly

61051-2644

2b

relative to said upper neck stretch portion and a shoulder stretch portion interconnecting a lower edge of said upper neck stretch portion and an upper edge of said lower neck stretch portion, at least one external tooth on said locking wall portion, said closure having a top, a downward extending upper skirt portion depending from said top, at least one second helical thread on an interior surface of said upper skirt portion shaped to mate with said at least one first helical thread, a lower skirt portion below said upper skirt portion, said lower skirt portion comprising an outer skirt portion offset outwardly relative to said upper skirt portion and a shoulder extending inwardly from an upper edge of the said outer skirt portion to a lower edge of said upper skirt portion, frangible means interconnecting said upper skirt portion and said shoulder, a line of weakness extending through said shoulder and said outer skirt portion, at least one internal tooth on said lower skirt portion shaped to engage said at least one external tooth to lock said closure relative to said neck until said frangible means are broken, said at least one first and second helical threads being shaped such that when said closure is moved directly axially downward on said neck without externally imposed relative rotation, said at least one first and second helical threads slip past each other allowing said container closure to engage said container neck.

According to yet another aspect the invention provides a container closure for use with a container neck of the type having an upper opening, a downward extending upper neck stretch portion below the opening, at least one first helical thread on an exterior surface of the upper neck stretch portion, a locking wall portion below the upper

61051-2644

2c

neck stretch portion, the locking wall portion comprising a lower neck stretch portion offset outwardly relative to the upper neck stretch portion and a shoulder stretch portion extending inwardly from an upper edge of the lower neck stretch portion to a lower edge of the upper neck stretch portion, at least one external tooth on the locking wall portion, said closure having a top, a downward extending upper skirt portion depending from said top, at least one second helical thread on an interior surface of said upper skirt portion shaped to mate with the at least one first helical thread, a lower skirt portion below said upper skirt portion, said lower skirt portion comprising an outer skirt portion offset outwardly relative to said upper skirt portion and a horizontal shoulder extending inwardly from an upper edge of said outer skirt portion to a lower edge of said upper skirt portion, frangible means interconnecting said upper skirt portion and said shoulder, at least one internal tooth on said lower skirt portion shaped to engage the at least one external tooth to lock said closure relative to the neck until said frangible means are broken, the at least one first helical thread and said at least one second helical thread being shaped such that when said closure is moved directly axially downward on the neck without externally imposed relative rotation, the at least one first helical thread and said at least one second helical thread slip past each other allowing said container closure to engage said container neck.

More particularly, in a preferred embodiment the neck finish of the present invention includes a downward extending upper neck stretch portion having at least one helical thread formed on the neck exterior. A locking wall portion is disposed below the upper neck stretch. The

61051-2644

2d

locking wall comprises a lower neck stretch portion offset outwardly relative to the upper neck stretch portion and a shoulder stretch portion. The shoulder stretch extends inwardly from the lower neck stretch, interconnecting the
5 lower neck stretch and the upper neck stretch. To secure the tamper-evident closure on the container, at least one external ratchet tooth is formed on the locking wall. The ratchet teeth are located on the

lower neck stretch in the preferred embodiment; however, the teeth may alternatively be positioned on the shoulder stretch.

The cap of the present invention comprises a top having
5 a depending upper skirt having at least one helical thread formed on its inner surface. The threads of the neck and the cap are cooperatively shaped to slip past one another and interengage when the cap is pushed onto the neck. A lower skirt disposed below the upper skirt comprises a
10 shoulder and an outer skirt portion offset outwardly from the upper skirt. The shoulder extends inwardly from the outer skirt, interconnecting the upper edge of the outer skirt and the lower edge of the upper skirt. At least one internal ratchet tooth is formed on the inner surface of the
15 lower skirt, positioned and shaped to engage the ratchet teeth of the neck when the cap is applied to the container. In the preferred embodiment, the internal ratchet tooth is formed on the outer skirt. Alternatively, the ratchet teeth may be located on the shoulder.

20 The upper skirt and shoulder are connected together by a frangible section, such as a plurality of radially spaced bridges. Alternatively, a line of weakness may be formed through the cap along the intersection between the shoulder and upper skirt portion. As the closure is applied to the
25 neck finish, the ratchet teeth on the locking wall and lower skirt interengage to prevent any twisting of the cap relative to the container. To open the container, the lower skirt must be torn from the closure, fracturing the frangible section between the shoulder and the upper skirt.
30 The ruptured frangible section provides evidence of tampering. Thus, the lower skirt and interlocking ratchet teeth are tamper evident features of the present invention.

When opening a container, if the consumer is not concentrating on the condition of the cap, he may not notice
35 the fractured frangible section of a previously opened

container. Therefore, in the preferred embodiment the cap of the present invention further comprises means for removing the cap from the container, such as a tear tab. The lower skirt is formed with a line of weakness extending through the outer skirt and the shoulder. The tear tab is located adjacent this line of weakness. To remove the lower skirt from the closure, the consumer pulls the tab, rupturing the line of weakness and the frangible section. Tampering with the contents of the container may be detected by even the distracted consumer, since the lower skirt must be removed before opening the container.

It has been contended that the lower skirt may be curled toward the upper skirt without rupturing the frangible section, releasing the internal teeth to permit twisting of the cap relative to the container without prior removal of the lower skirt. To provide further protection against tampering, a frangible, substantially vertical fin is formed between the upper skirt and shoulder. The fin prevents upward deformation of the lower skirt and, when broken, provides further evidence of tampering. In the preferred embodiment, the fin is located adjacent the line of weakness formed through the lower skirt. Upward deformation of the lower skirt will rupture the frangible section and the line of weakness extending through the lower skirt. Thus, the vertical fin and the line of weakness are additional tamper-evident features of the present invention.

In the preferred form, the line of weakness extending through the lower skirt is a continuous stretch of material. In an alternative embodiment, a groove is formed through the shoulder and outer skirt. The shoulder is formed with a first web material bridging the groove, while the outer skirt is formed having a second web material bridging the groove. The first and second web materials are separated by a gap adjacent the intersection of the shoulder and the outer skirt. The gap between the first and second web materials increases the amount by which the lower skirt is

distorted as it is curled upward, thereby facilitating the rupturing of the line of weakness.

BRIEF DESCRIPTION OF THE DRAWINGS

The accompanying drawings, which are incorporated in
5 and form a part of this specification, illustrate
embodiments of the invention and, together with the
description, serve to explain the principles of the
invention:

Figure 1 is a perspective view of a cap showing
10 possible upward deformation of the lower skirt portion
relative to the cap.

Figure 2 is a side elevational view of a cap and neck
before assembly, the cap being partially broken away in
section to reveal internal construction.

15 Figure 3 is a fragmentary enlarged bottom plan of the
cap.

Figure 4 is a fragmentary enlarged top plan of the cap.

Figure 5 and 6 are, respectively, enlarged, fragmentary
sectional views taken along line 5--5 and 6--6 of Figure 4.

20 Figure 7 is an enlarged, fragmentary sectional view
taken along line 7--7 of Figure 2, showing a preferred
cross-sectional shape of a line of weakness.

Figure 8 is a fragmentary enlarged top plan of an
alternative embodiment of a cap of the present invention.

25 Figure 9 is an enlarged, fragmentary sectional view
taken along line 9--9 of Figure 8.

Figure 10 is an enlarged top view of another
alternative embodiment of a cap of the present invention.

Figure 11 is a side elevational view of the cap of Figure 10.

Figure 12 is a fragmentary sectional view taken along line 12-12 of Figure 10.

5 DETAILED DESCRIPTION OF THE PREFERRED EMBODIMENTS

Reference will now be made in detail to the preferred embodiments of the invention, examples of which are illustrated in the accompanying drawings. While the invention will be described in conjunction with the preferred embodiments, it will be understood that they are not intended to limit the invention to those embodiments. On the contrary, the invention is intended to cover alternatives, modifications and equivalents, which may be included within the spirit and scope of the invention as defined by the appended claims.

Closure 21, hereinafter described in detail, is used with a container neck 22. The interior of the neck forms no part of the present invention. With a blow-molded bottle finish, the interior contour tends to follow that of the neck exterior. However, it will be understood that other types of bottles may be used, with the internal shape of the neck varying from that of the exterior.

Neck 22 has a central opening 23 and a downward-outward slanted lip flange 24 terminating in a vertical stretch 28. Threads 29 extend outward of stretch 28. In the illustrated embodiment, there are two threads 29a and 29b. The finish has twelve threads per inch with a double lead, each thread being six pitch and extending slightly in excess of 360° of a full thread. It is to be understood that the threads may be extended greater than 360° for increased thread engagement. Additionally, the thread leads may be of a different linear thread density (threads per inch). The upper flank 36 of thread 29 slants downwardly/outwardly at approximately 45° while the lower flank slants downwardly/

61051-2644

7

inwardly at approximately 10° , permitting the threads on the interior of the cap to slip past the threads on the neck finish. Preferably, the thread apex 38 is made with as large a radius as possible.

5 Instead of cooperatively shaped threads on the upper neck stretch portion and the inner surface of the closure, one thread may be replaced by a groove. Further, threads 29 may be interrupted, instead of continuous.

10 Below the vertical stretch is downward extending locking wall portion 40. The locking wall portion has a shoulder stretch portion 42 and a lower neck stretch portion 46 offset outwardly relative to the upper neck stretch portion. In the illustrated embodiment, the lower neck portion slants downwardly/outwardly at an angle of
15 approximately 10° and terminates in generally horizontal shoulder 47. A vertical stretch 48 depends from shoulder 47. To facilitate gripping of the container during filling and loading, vertical stretch 48 may be formed with a number of bumper ring segments 49 (here shown as four in number).

20 A number of ratchet teeth 51 project from lower stretch 46 on opposite sides of neck 22. Typically, three teeth 51 are formed on either side of neck 22, with the total extent of the three teeth being approximately 90° . The teeth 51 are shaped to interengage the internal ratchet
25 teeth formed on the cap, preventing twisting of the cap relative to the neck. In the illustrated embodiment, teeth 51 are formed on lower stretch 46. However, in alternative forms of the present invention the teeth may be located on shoulder stretch 42, interengaging ratchet teeth formed on
30 the shoulder of the cap, as is discussed below.

61051-2644

8

A cap for use with neck structure 22 is illustrated in FIGS. 2 to 7. The cap has top 61 from the periphery of which depends downward extending upper skirt stretch 62. As illustrated, the top comprises a generally flat top disk; however, other configurations may be substituted.

The upper edge of upper skirt stretch 62 merges with slanted skirt stretch 63, which in turn merges with upper skirt portion 64, also referred to as vertical skirt stretch 64. An internal shoulder 65 is formed at the intersection of upper and slanted skirt stretches 62 and 63. Skirt stretches 62, 63 and 64 have radially spaced vertical ribs 66 to enable the user to grip the cap.

Threads 71a and 71b, which are selected to mate with threads 29 of neck 22, are formed on the interior of the skirt. The shape of threads 29a, 29b, 71a and 71b allow the threads to slip passed one another and then interengage. Threads 71a and 71b are double lead and extend around the circumference of the cap in excess of 180°, for example, approximately 200°. In conventional capping machines, cap 21 is deposited on neck 22. Since threads 71a, 71b are diametrically opposed, the cap tends to rest horizontally on neck 22, facilitating the application of the cap onto the neck with a downward, axial force.

The closure has ring-like skirt or lower skirt portion 70 below upper skirt portion 64. The lower skirt comprises outer skirt portion 74 offset outwardly relative to upper skirt portion 64 and a shoulder 73 extending inwardly from the upper edge of the outer skirt portion. A frangible section including a number of radially spaced bridges 76 interconnects the shoulder and the upper skirt

61051-2644

9

portion. In the illustrated embodiment, the lower edges of ribs 66 form the bridges. Alternatively, a line of weakness may be formed through the intersection of shoulder 73 and upper skirt portion 64.

5 A number of internal ratchet teeth 81 spaced and dimensioned to match the teeth 51 of neck 22 are formed on outer skirt portion 74. Teeth 81 are positioned to engage teeth 51 when cap 21 is pushed onto neck 22. After cap application, the inner edges 82 of teeth 81 are positioned
10 close to lower stretch 46. The interlocking engagement between the teeth on the cap with those on the neck prevent twisting of the cap relative to the container while the lower skirt is intact. Teeth 81 are located on the outer skirt in the present embodiment; however, the teeth may
15 alternatively be positioned along the inner surface of shoulder 73. The teeth formed on the shoulder surface would be shaped and positioned to interengage teeth located on the shoulder stretch of neck 22. When the closure is applied to the neck, the ratchet teeth on the opposing surfaces of
20 shoulder 73 and shoulder stretch 42 interlock, preventing removal of the cap so long as the line of weakness is not broken.

 The interengagement between ratchet teeth 51 and 81 prevent twisting of the cap relative to the neck. To
25 remove the closure, the lower skirt must first be separated from the upper skirt, as by rupturing of the frangible section, allowing the cap to be unscrewed from the container. The ruptured bridges warn the consumer that the container has been opened and the contents tampered with.
30 Thus, the interlocking ratchet teeth and frangible bridges

61051-2644

10

of the present invention are a tamper-evident feature of the present invention.

In the preferred embodiment, a tear tab 86 is connected to the lower edge of outer skirt 74. The tear tab provides means for removing the lower skirt, and may be used to orient cap 21 relative to the container. Lower skirt 70 is formed with a line of weakness generally indicated by 87 extending through outer skirt 74 and shoulder 73. The line of weakness facilitates removal of the lower skirt from the closure, and is another tamper-evident feature of the present invention. When initially opening the container, the consumer pulls tab 86 to remove lower skirt 70, rupturing line 87 and frangible section 76. The absence of the lower skirt more dramatically alerts the consumer to possible tampering of the contents. A distracted consumer may fail to notice the fractured bridges, therefore the removal of the lower skirt is a more obvious indication of tampering.

It has been contended that the tamper-evident features of the closure which have been described up to this point may be circumvented by curling the lower skirt 70 in an upward direction. A cap having a partially deformed lower skirt is shown in FIG. 1. With the lower skirt completely deformed upward, teeth 51 and 81 will no longer interengage, and cap 21 may be twisted relative to the container for removal. In practice, this manipulation of the closure will usually fracture bridges 76. However, as discussed, the ruptured bridges may not be readily apparent to the distracted consumer.

To further safeguard the consumer from the dangers of tampering, a substantially vertical fin 100 is formed

61051-2644

11

between upper skirt portion 64 and shoulder 73. In one embodiment, vertical fin 100 is located adjacent line of weakness 87, as is shown particularly in FIGS. 3, 4 and 5. When a dishonest patron attempts to curl the lower skirt 70 towards the upper skirt, the deformation of the material below the vertical fin 100, generally indicated at 102, is resisted by the fin. This resistance distorts lower skirt 70, causing line of weakness 87 and frangible bridges 76 to rupture, providing evidence of tampering. Attempts by a dishonest patron to tamper with the contents of a container by curling the lower skirt to remove cap 21 will be revealed by the fracturing of frangible section 76 and line 87. Thus, vertical fin 100 provides additional protection against tampering.

15 In the preferred form, fin 100 is formed with a substantially vertical line of weakness 101 through the closure adjacent the upper skirt. As lower skirt 70 is torn from the closure, line of weakness 101 is ruptured and the fin removed from upper skirt portion 64 together with the lower skirt. The upper skirt is provided with an even, clean finish once vertical fin 100 is removed. However, if desired, the fin could be formed with a line of weakness extending through the fin adjacent shoulder 73. The fin would then remain intact on upper skirt portion 64 after removal of the lower skirt from the container.

In the alternative embodiment shown in FIGS. 10-12, improved tamper evidence is achieved by a camming action of dual fins 111 upstanding from shoulder 73. In this embodiment, the fins need not be joined to upper skirt portion 64. If a dishonest patron attempts to curl the lower skirt to tamper with the contents of the

61051-2644

12

container, dual fins 111 act as a cam to force the lower skirt radially outward, causing sufficient deformation of the lower skirt to fracture bridges 76 and line of weakness 87. A further advantage of the present embodiment is that
5 no residual material remains on upper skirt portion 64 after removal of lower skirt 70.

As is illustrated particularly in FIGS. 4 and 6, line of weakness 87 extending through lower skirt 70 is a continuous section of material. This configuration is
10 preferred as it is simple to manufacture. However, an alternative embodiment having a gap 104 at the intersection of shoulder 73 and outer skirt 74 is shown in FIGS. 8 and 9. Lower skirt 70 has a groove 106 extending through shoulder 73 and outer skirt 74. The shoulder is formed with a first
15 web material 108 bridging groove 106, while the outer skirt is formed having a second web material 110 bridging the groove. The first and second web materials 108, 110 are separated by gap 104.

With the embodiments illustrated in FIGS. 2 to 7
20 and FIGS. 10 to 12, upward deformation of the lower skirt stretches the lower edge of the outer skirt, placing the corner between the shoulder and the outer skirt in compression. Removing material from the corner and forming
25 gap 104, as in FIGS. 8 and 9, increases the amount of distortion caused by curling the lower skirt, thereby facilitating the fracturing of line of weakness 87. Thus, the alternative embodiment provides an additional tamper-evident feature of the cap of the present invention.

In feeding the snap-on screw-off closure,
30 orientation is generally achieved by causing tear tab 86 to be at the trailing edge, riding in a slot cutout of the cap

61051-2644

13

feed chute. It has been observed that occasionally the lower skirt 70 of a trailing cap will ride up onto the shoulder 73 of the preceding cap directly above the tear tab 86 of the preceding cap. This causes a jam and stops the flow of caps. It is readily apparent that an additional benefit of fin 100 and dual fins 111 of the present invention is the prevention of the occurrence of jamming.

PREFERRED OPERATION

After the container has been filled, it is transported through a capping machine. As is well understood in the bottling art, and in a manner similar to that whereby push-on, snap-off caps are applied, caps 21 are fed one at a time out of a bowl in the capping machine, with tear tab 86 orienting the caps for uniform discharge in a predetermined orientation relative to the containers passing therebelow. Although not shown in the accompanying drawings, each container has a square cross-section or some other variation from a round shape which permits the container to be oriented relative to cap 21. The structure of capping machines is well known in the bottling art. Because of the relative orientation of cap 21 and neck 22, teeth 51 and 81 are in vertical alignment. An axially downward force is applied to the cap, pushing the cap onto the neck. Threads 71a and 71b slip over threads 29a and 29b, the slanted surfaces 36 facilitating such movement. The cap is sufficiently resilient so that it expands outward sufficiently to permit the threads to slip. As cap 21 seats on the neck, teeth 81 engage behind teeth 51 to fully engage teeth 81 in place.

After the cap has been fully seated on neck 22, it can not be removed without providing evidence of tampering.

61051-2644

14

The interengagement between teeth 51 and 81 prevent unscrewing of the cap from the container, while the interengagement between the threads prevents lifting of cap 21 off neck 22. Substantially vertical fin 100 or dual fins 111 prevent upward deformation of the lower skirt without rupturing frangible bridges 76 and line of weakness 87. Thus, any attempts to tamper with the contents of the container will be revealed to the consumer.

When a consumer desires to initially open the container, he grips tap 86 and pulls circumferentially around the container causing lower skirt 70 and vertical fin 100 to be removed. Ratchet teeth 81 are thereby removed from interlocking engagement with ratchet teeth 51, providing evidence of tampering and enabling the consumer to unscrew cap 21 from neck 22. To replace the cap, the consumer merely reverses the direction of twisting.

The foregoing descriptions of specific embodiments of the present invention have been presented for purposes of illustration and description. They are not intended to be exhaustive or to limit the invention to the precise forms disclosed, and obviously many modifications and variations are possible in light of the above teaching. The embodiments were chosen and described in order to best explain the principles of the invention and its practical application, to thereby enable others skilled in the art to best utilize the invention and various embodiments with various modifications as are suited to the particular use contemplated. It is intended that the scope of the invention be defined by the claims appended hereto and their equivalents.

61051-2644

15

CLAIMS:

1. In combination, a container neck and a container closure,

said neck having an upper opening, a downward
5 extending upper neck stretch portion below said opening, at
least one first helical thread on an exterior surface of
said upper neck stretch portion, a locking wall portion
below said upper neck stretch portion, said locking wall
portion comprising a lower neck stretch portion offset
10 outwardly relative to said upper neck stretch portion and a
shoulder stretch portion interconnecting a lower edge of
said upper neck stretch portion and an upper edge of said
lower neck stretch portion, at least one external tooth on
said locking wall portion,

15 said closure having a top, a downward extending
upper skirt portion depending from said top, at least one
second helical thread on an interior surface of said upper
skirt portion shaped to mate with said at least one first
helical thread, a lower skirt portion below said upper skirt
20 portion, said lower skirt portion comprising an outer skirt
portion offset outwardly relative to said upper skirt
portion and a shoulder extending inwardly from an upper
edge of said outer skirt portion to a lower edge of said
upper skirt portion, frangible means interconnecting said
25 upper skirt portion and said shoulder, at least one internal
tooth on said lower skirt portion shaped to engage said at
least one external tooth to lock said closure relative to
said neck until said frangible means are broken,

said at least one first and second helical threads
30 being shaped such that when said closure is moved directly

61051-2644

16

axially downward on said neck without externally imposed relative rotation, said at least one first and second helical threads slip past each other allowing said container closure to engage said container neck.

5 2. The combination of claim 1 in which said neck comprises two threads, each said thread extending in excess of 360°.

3. The combination of claim 1 in which said closure comprises at least one substantially vertical fin upstanding
10 from said shoulder to engage said upper skirt portion upon upward deformation of said lower skirt portion and cause breakage of said frangible means which is formed with a substantially vertical line of weakness extending through
15 said at least one substantially vertical fin adjacent said upper skirt portion, whereby said at least one substantially vertical fin is a tamper-evident feature of said combination.

4. The combination of claim 1 in which said lower skirt portion is formed with a line of weakness extending
20 through said shoulder and said outer skirt portion.

5. The combination of claim 4 in which said line of weakness comprises a groove formed through said lower skirt portion, said shoulder formed having a first web material bridging said groove and said outer skirt portion formed
25 having a second web material bridging said groove.

6. The combination of claim 5 in which said first and second web materials are separated by a gap adjacent the intersection of said shoulder and said outer skirt portion.

61051-2644

17

7. The combination of claim 4 further comprising a tear tab connected to said lower skirt portion adjacent said line of weakness.

8. The combination of claim 1 in which said frangible means comprises a plurality of radially spaced bridges.

9. The combination of claim 1 in which said at least one external tooth is located on said lower neck stretch and said at least one internal tooth is located on said outer skirt portion.

10. In combination, a container neck and a container closure,

said neck having an upper opening, a downward extending upper neck stretch portion below said opening, at least one first helical thread on an exterior surface of said upper neck stretch portion, a locking wall portion below said upper neck stretch portion, said locking wall portion comprising a lower neck stretch portion offset outwardly relative to said upper neck stretch portion and a shoulder stretch portion interconnecting a lower edge of said upper neck stretch portion and an upper edge of said lower neck stretch portion, at least one external tooth on said locking wall portion,

said closure having a top, a downward extending upper skirt portion depending from said top, at least one second helical thread on an interior surface of said upper skirt portion shaped to mate with said at least one first helical thread, a lower skirt portion below said upper skirt portion, said lower skirt portion comprising an outer skirt portion offset outwardly relative to said upper skirt portion and a shoulder extending inwardly from an upper

61051-2644

18

edge of the said outer skirt portion to a lower edge of said upper skirt portion, frangible means interconnecting said upper skirt portion and said shoulder, a line of weakness extending through said shoulder and said outer skirt
5 portion, at least one internal tooth on said lower skirt portion shaped to engage said at least one external tooth to lock said closure relative to said neck until said frangible means are broken,

said at least one first and second helical threads
10 being shaped such that when said closure is moved directly axially downward on said neck without externally imposed relative rotation, said at least one first and second helical threads slip past each other allowing said container closure to engage said container neck.

15 11. The combination of claim 10 in which said line of weakness comprises a groove formed through said lower skirt portion, said shoulder formed having a first web material bridging said groove and said outer skirt portion formed having a second web material bridging said groove.

20 12. The combination of claim 11 in which said first and second web materials are separated by a gap adjacent the intersection of said shoulder and said outer skirt portion.

13. The combination of claim 10 which further
25 comprises at least one substantially vertical fin upstanding from said shoulder to engage said upper skirt portion upon upward deformation of said lower skirt portion and cause breakage of said frangible means, whereby said at least one substantially vertical fin is a tamper-evident feature of said combination.

61051-2644

19

14. The combination of claim 13 in which said at least one substantially vertical fin is located adjacent said line of weakness.

15. The combination of claim 10 in which said at least one external tooth is located on said lower neck stretch portion and said at least one internal tooth is located on said outer skirt portion.

16. The combination of claim 10 which further comprises a tear tab connected to said lower skirt portion adjacent said line of weakness.

17. The combination of claim 10 in which said upper skirt is formed with external ribs, lower edges of said ribs comprising said frangible means.

18. A container closure for use with a container neck of the type having an upper opening, a downward extending upper neck stretch portion below the opening, at least one first helical thread on an exterior surface of the upper neck stretch portion, a locking wall portion below the upper neck stretch portion, the locking wall portion comprising a lower neck stretch portion offset outwardly relative to the upper neck stretch portion and a shoulder stretch portion extending inwardly from an upper edge of the lower neck stretch portion to a lower edge of the upper neck stretch portion, at least one external tooth on the locking wall portion,

said closure having a top, a downward extending upper skirt portion depending from said top, at least one second helical thread on an interior surface of said upper skirt portion shaped to mate with the at least one first helical thread, a lower skirt portion below said upper skirt

61051-2644

20

portion, said lower skirt portion comprising an outer skirt portion offset outwardly relative to said upper skirt portion and a horizontal shoulder extending inwardly from an upper edge of said outer skirt portion to a lower edge of said upper skirt portion, frangible means interconnecting said upper skirt portion and said shoulder, at least one internal tooth on said lower skirt portion shaped to engage the at least one external tooth to lock said closure relative to the neck until said frangible means are broken,

10 the at least one first helical thread and said at least one second helical thread being shaped such that when said closure is moved directly axially downward on the neck without externally imposed relative rotation, the at least one first helical thread and said at least one second
15 helical thread slip past each other allowing said container closure to engage said container neck.

19. The closure of claim 18 in which said neck comprises two threads, each said thread extending in excess of 360°.

20 20. The closure of claim 18 in which said closure comprises at least one substantially vertical fin upstanding from said shoulder to engage said upper skirt portion upon upward deformation of said lower skirt portion and cause breakage of said frangible means which is formed with a
25 substantially vertical line of weakness extending through said at least one substantially vertical fin adjacent said upper skirt portion, whereby said at least one substantially vertical fin is a tamper-evident feature of said closure.

21. The closure of claim 20 in which said shoulder and
30 said lower skirt portion are formed with a second line of

61051-2644

21

weakness extending through said shoulder and said outer skirt portion.

22. The closure of claim 21 in which said at least one substantially vertical fin is located adjacent said second
5 line of weakness.

23. The closure of claim 21 in which said second line of weakness comprises a groove formed through said shoulder and said outer skirt portion, said shoulder formed having a first web material bridging said groove and said outer skirt
10 portion formed having a second web material bridging said groove.

24. The closure of claim 23 in which said first and second web materials are separated by a gap adjacent the intersection of said shoulder and said outer skirt portion.

15 25. The closure of claim 18 in which said at least one internal tooth is located on said outer skirt portion.

SMART & BIGGAR

OTTAWA, CANADA

PATENT AGENTS

1/4

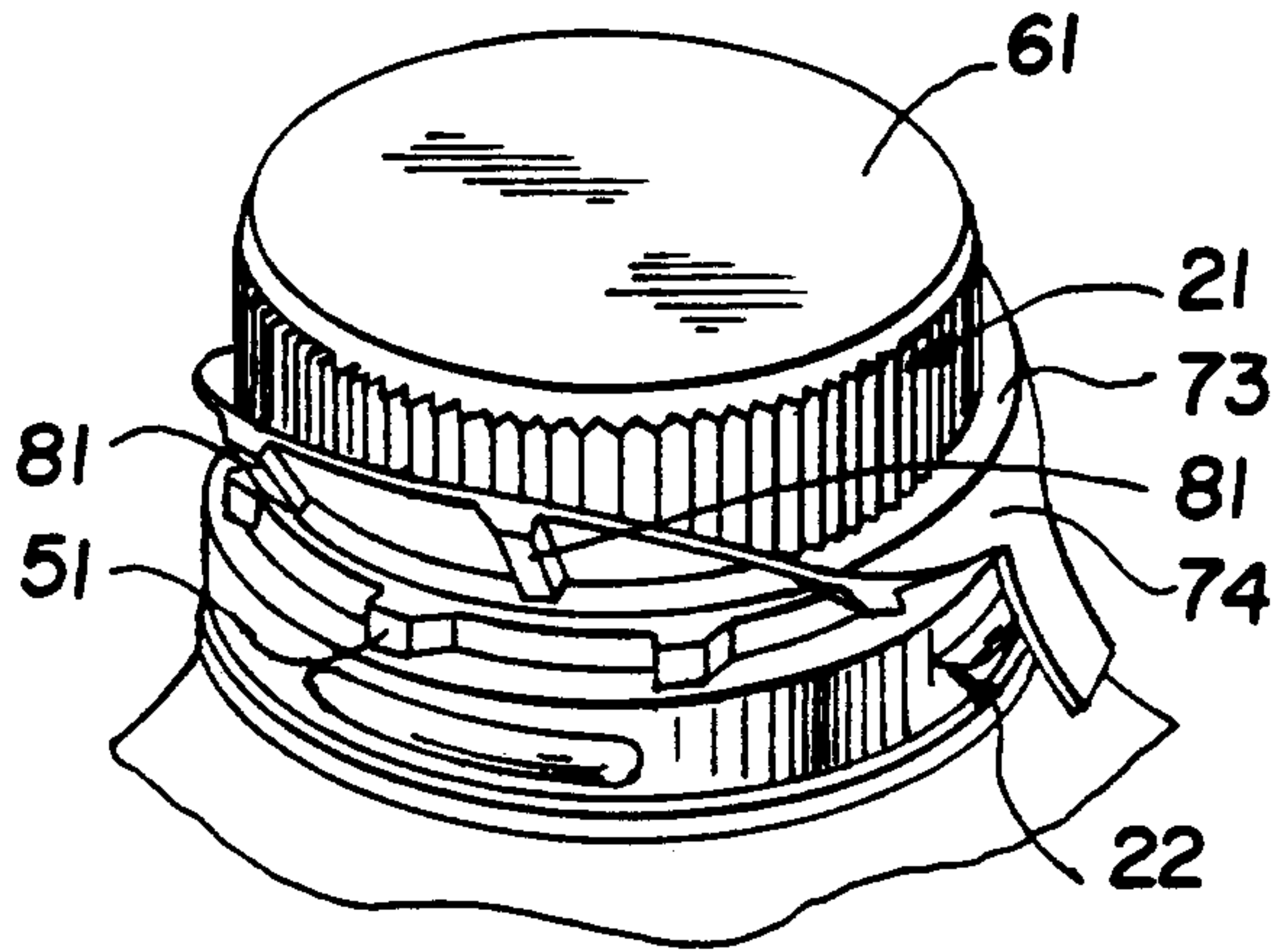

FIG. 1

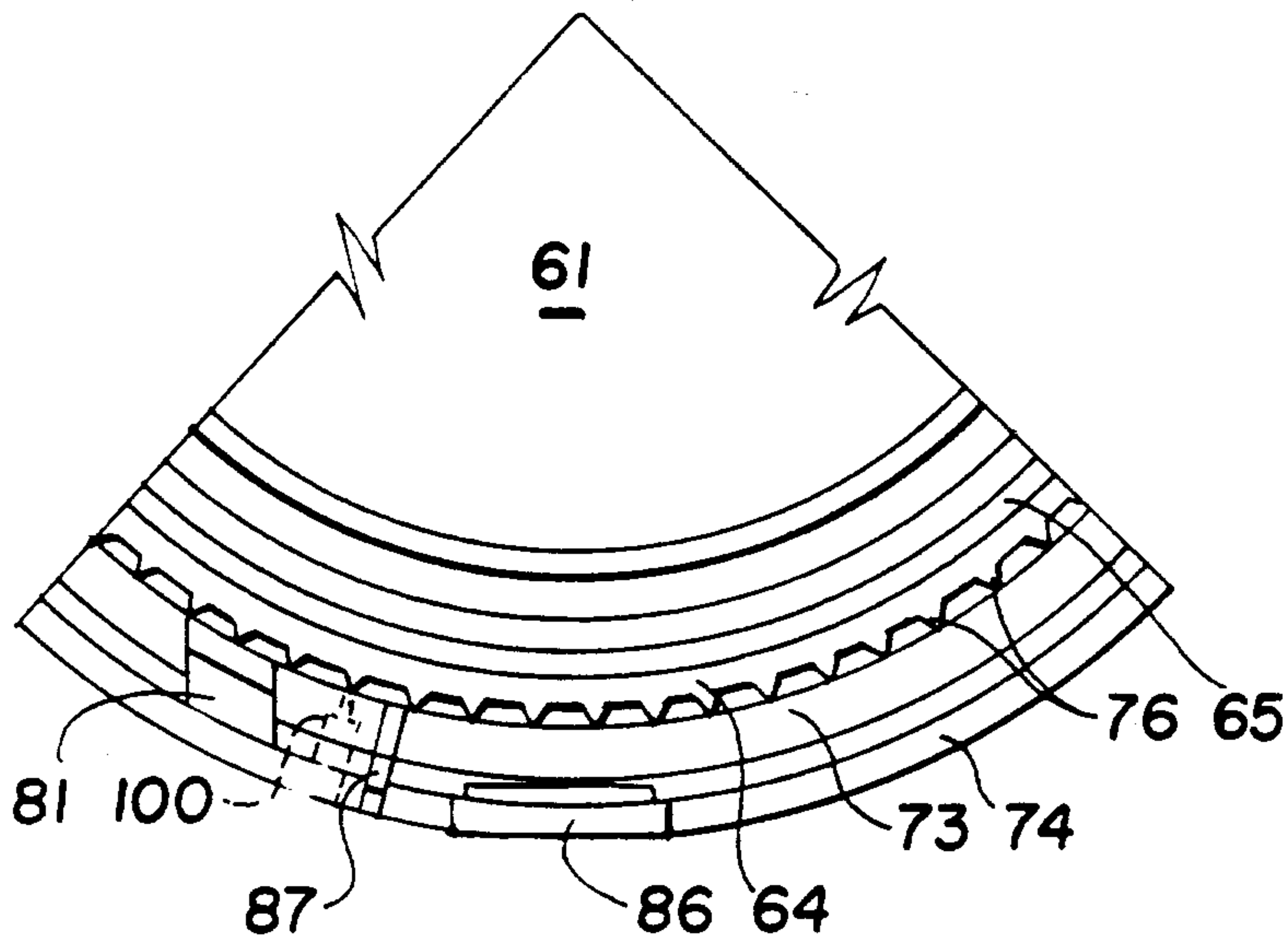

FIG. 3

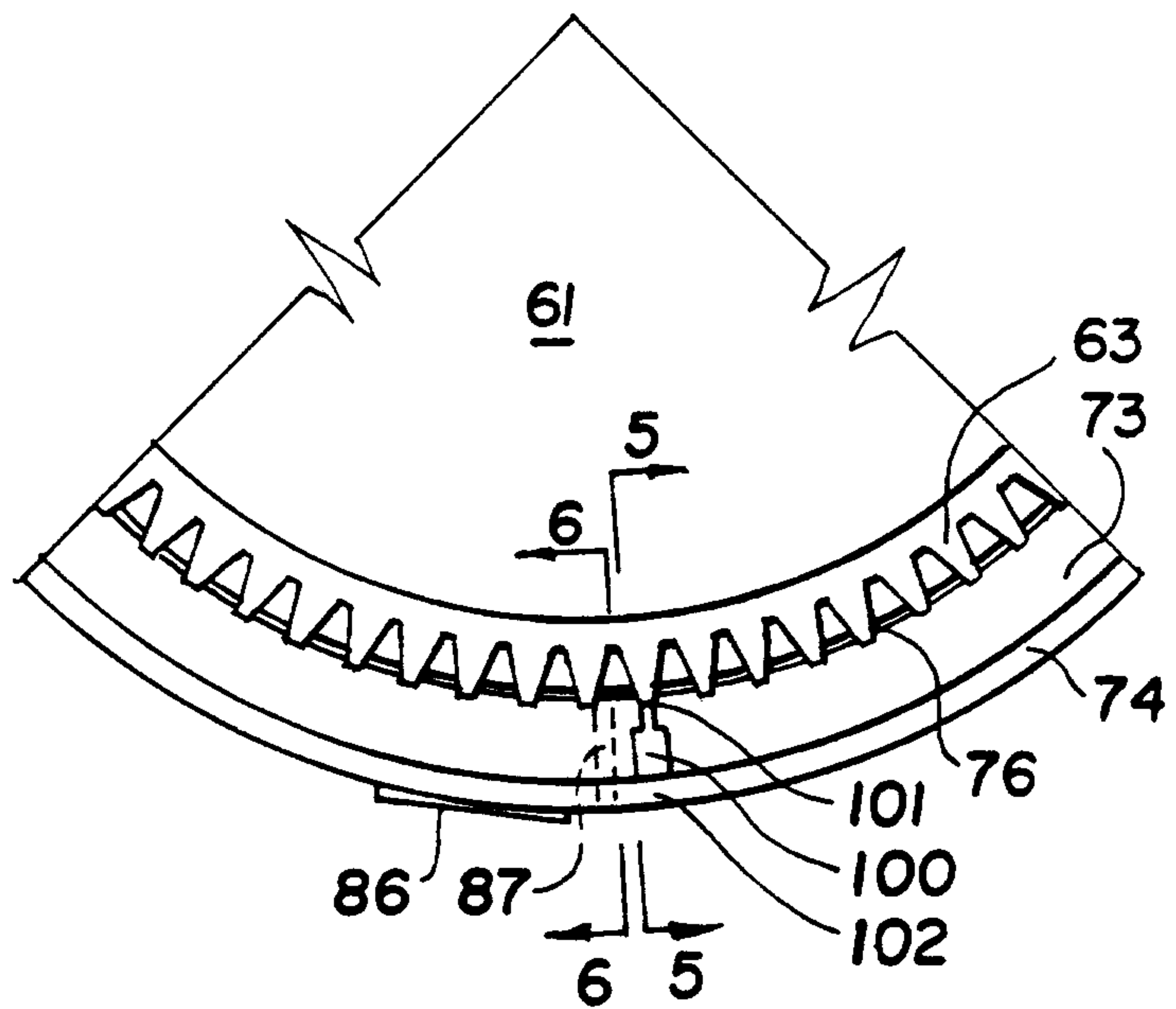

FIG. 4

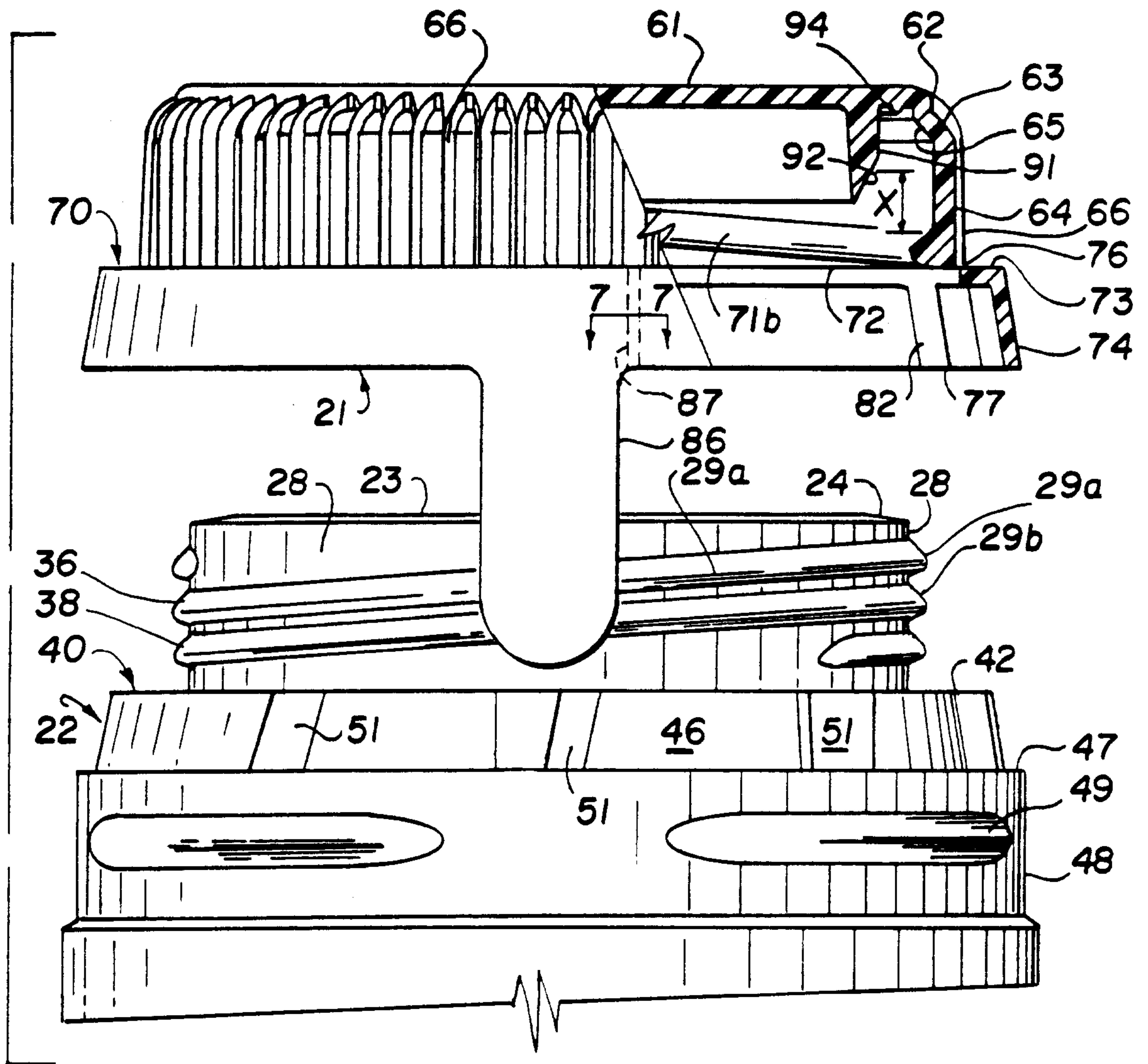

FIG. 2

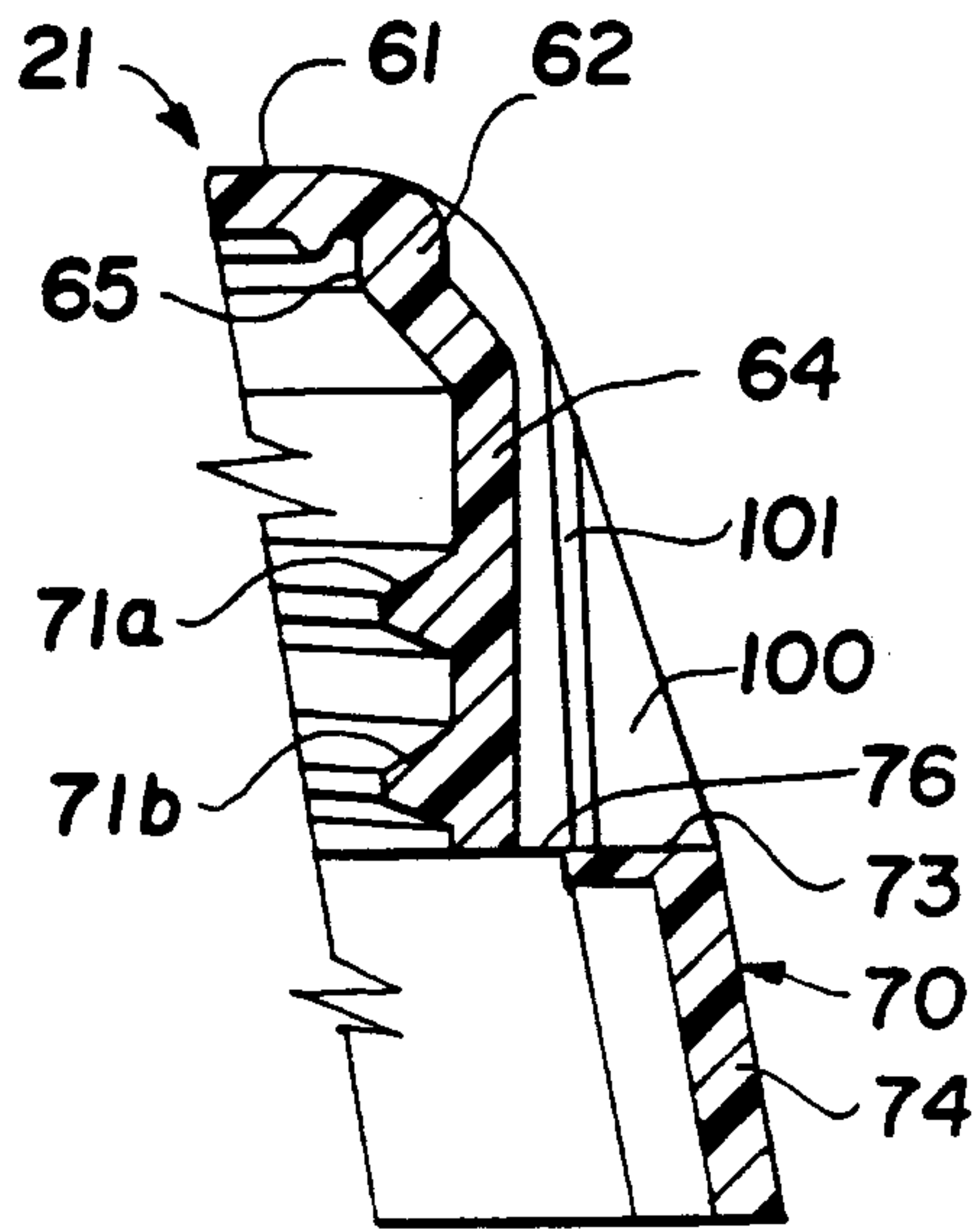

FIG. 5

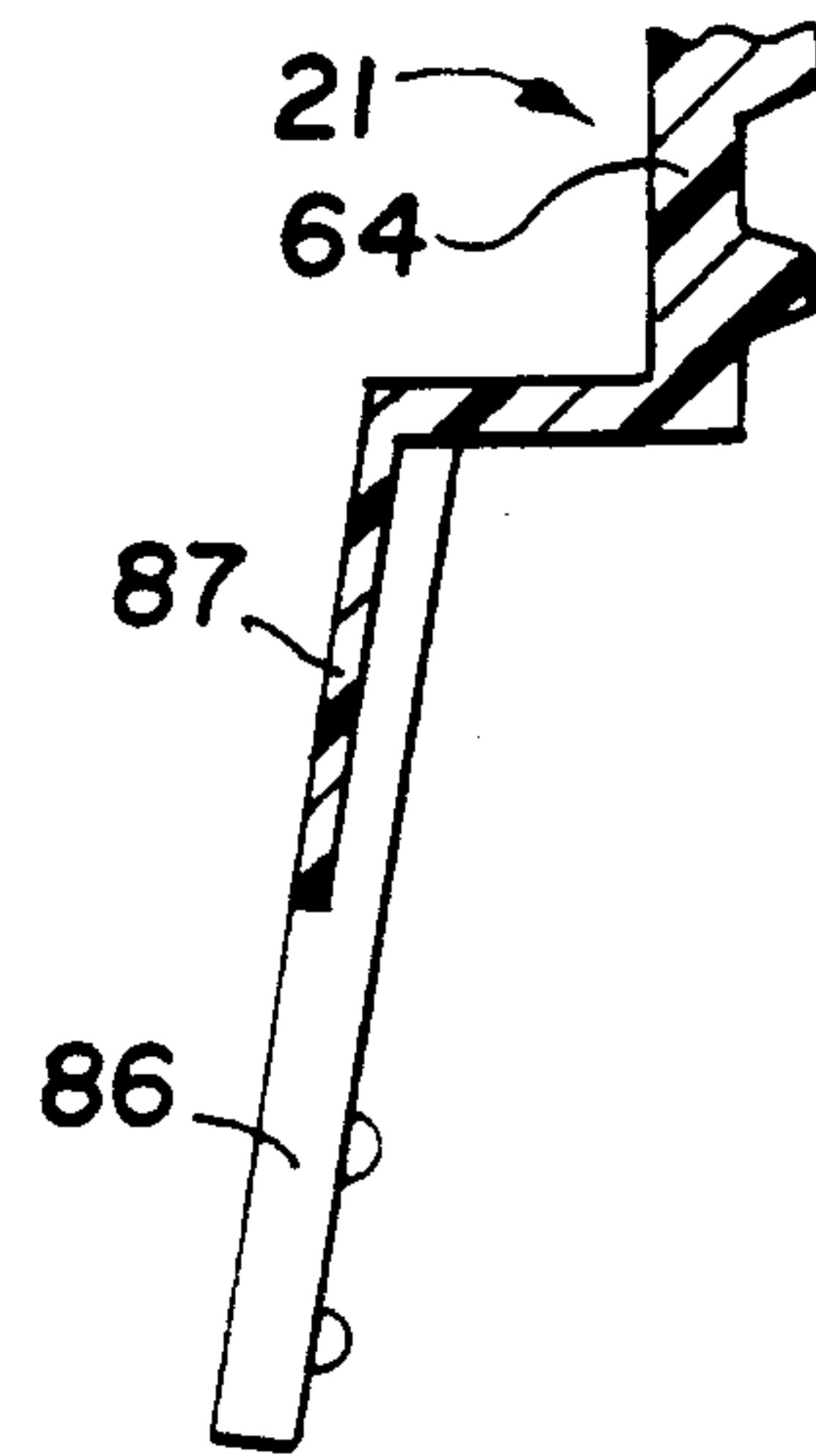

FIG. 6

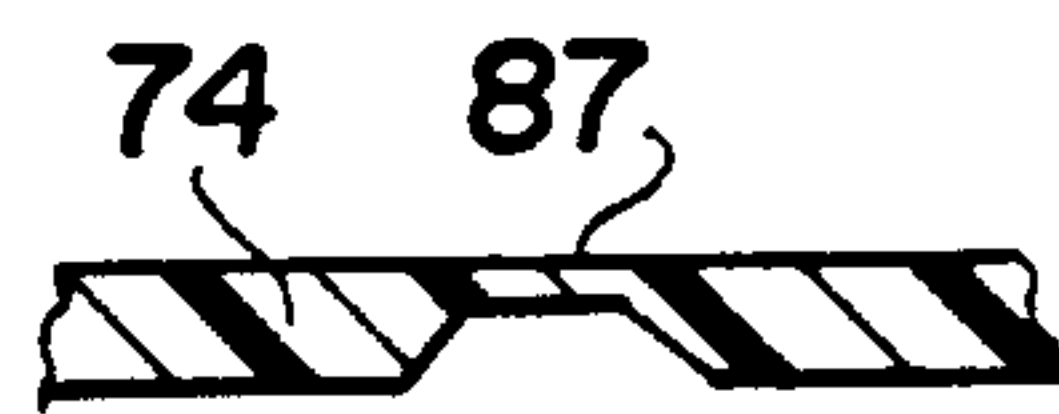

FIG. 7

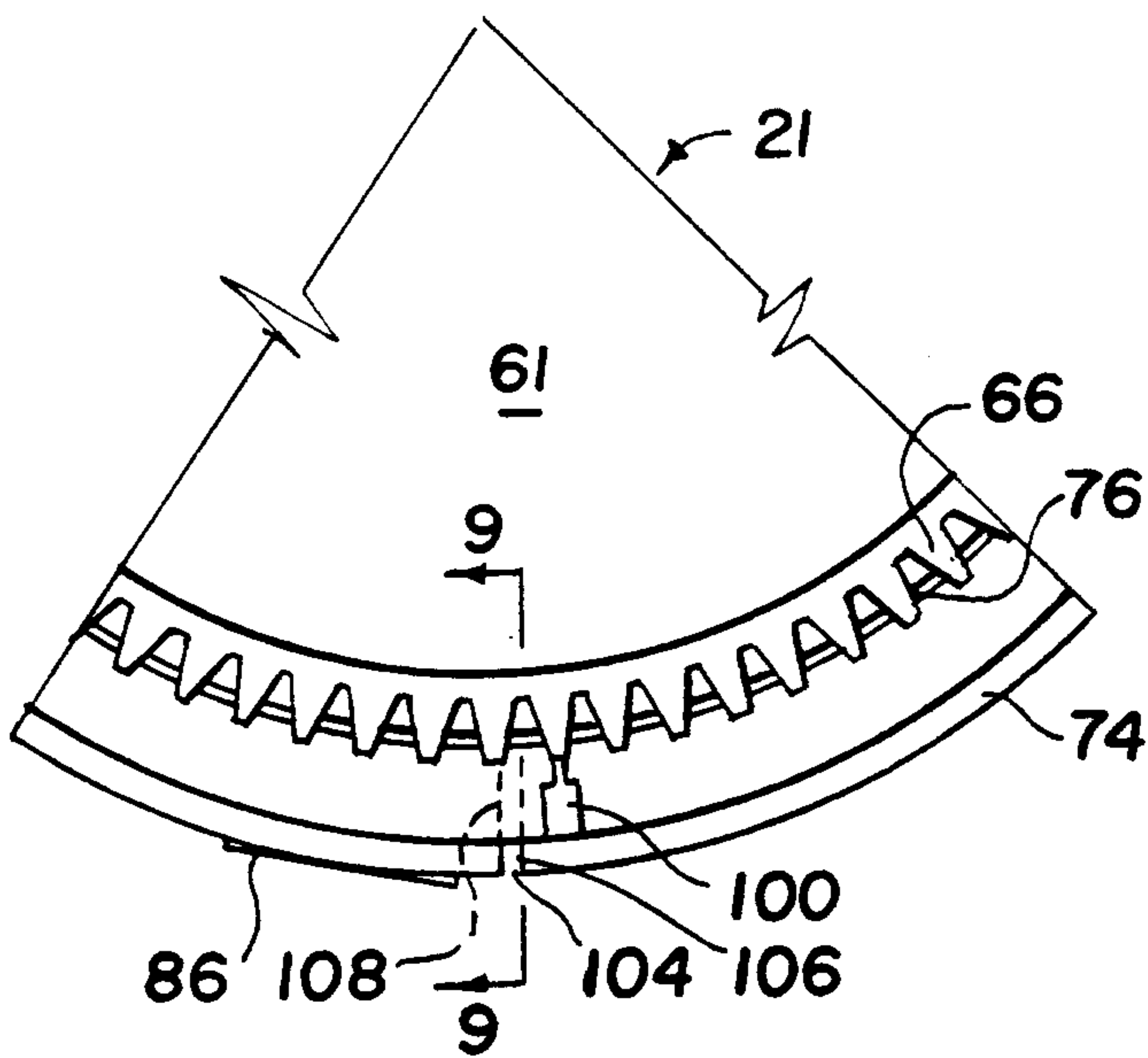

FIG. 8

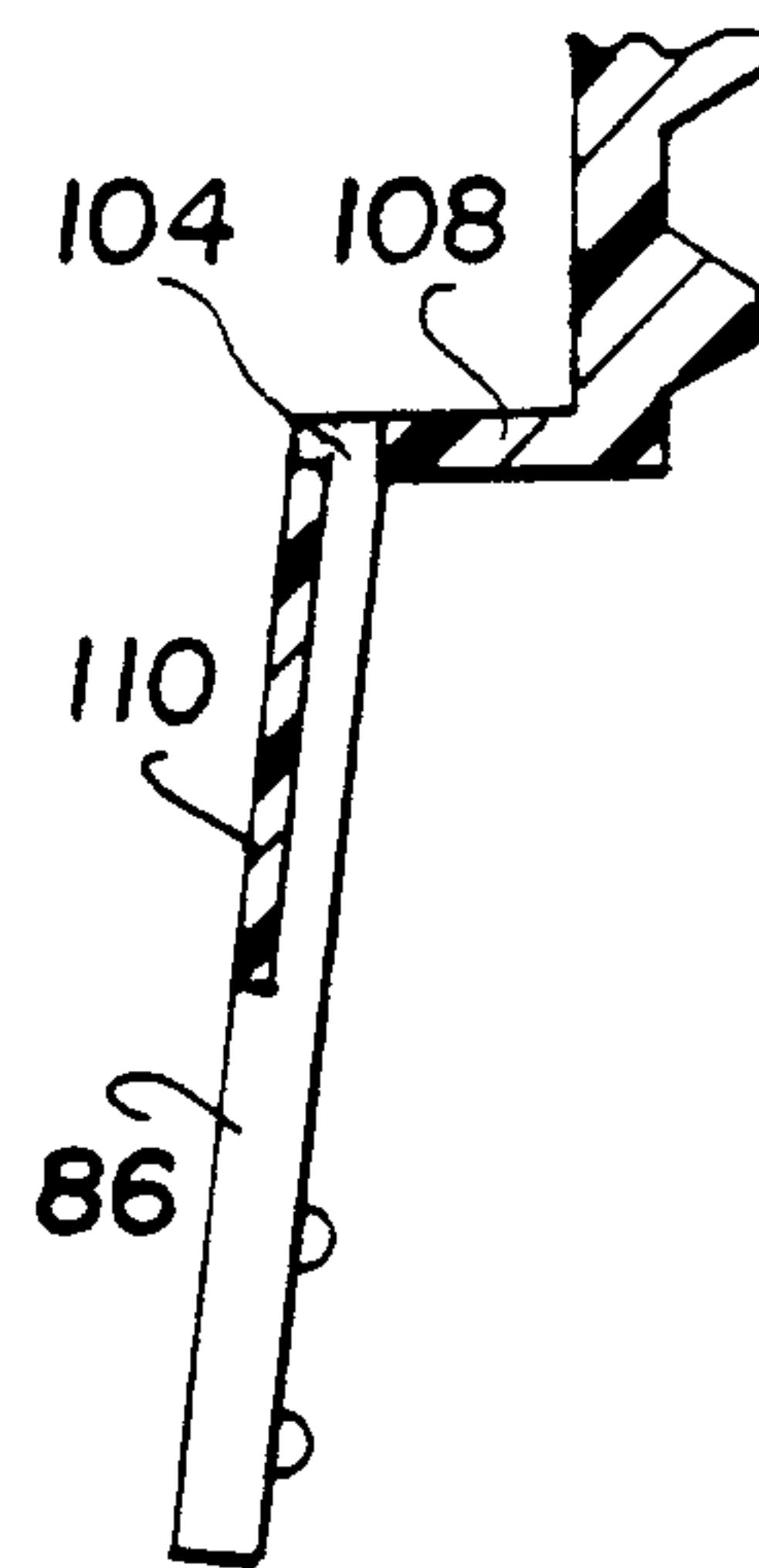

FIG. 9

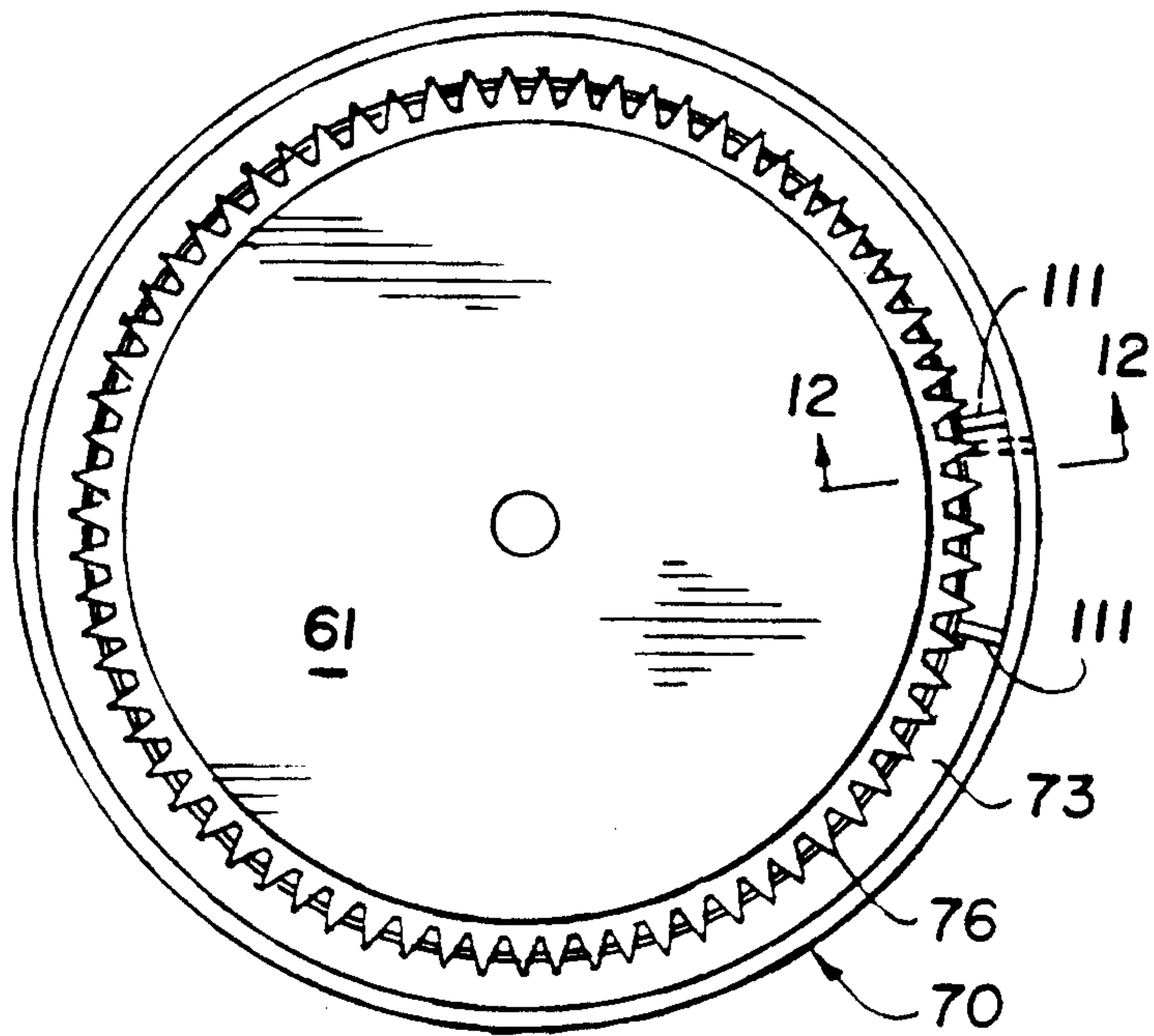

FIG. 10

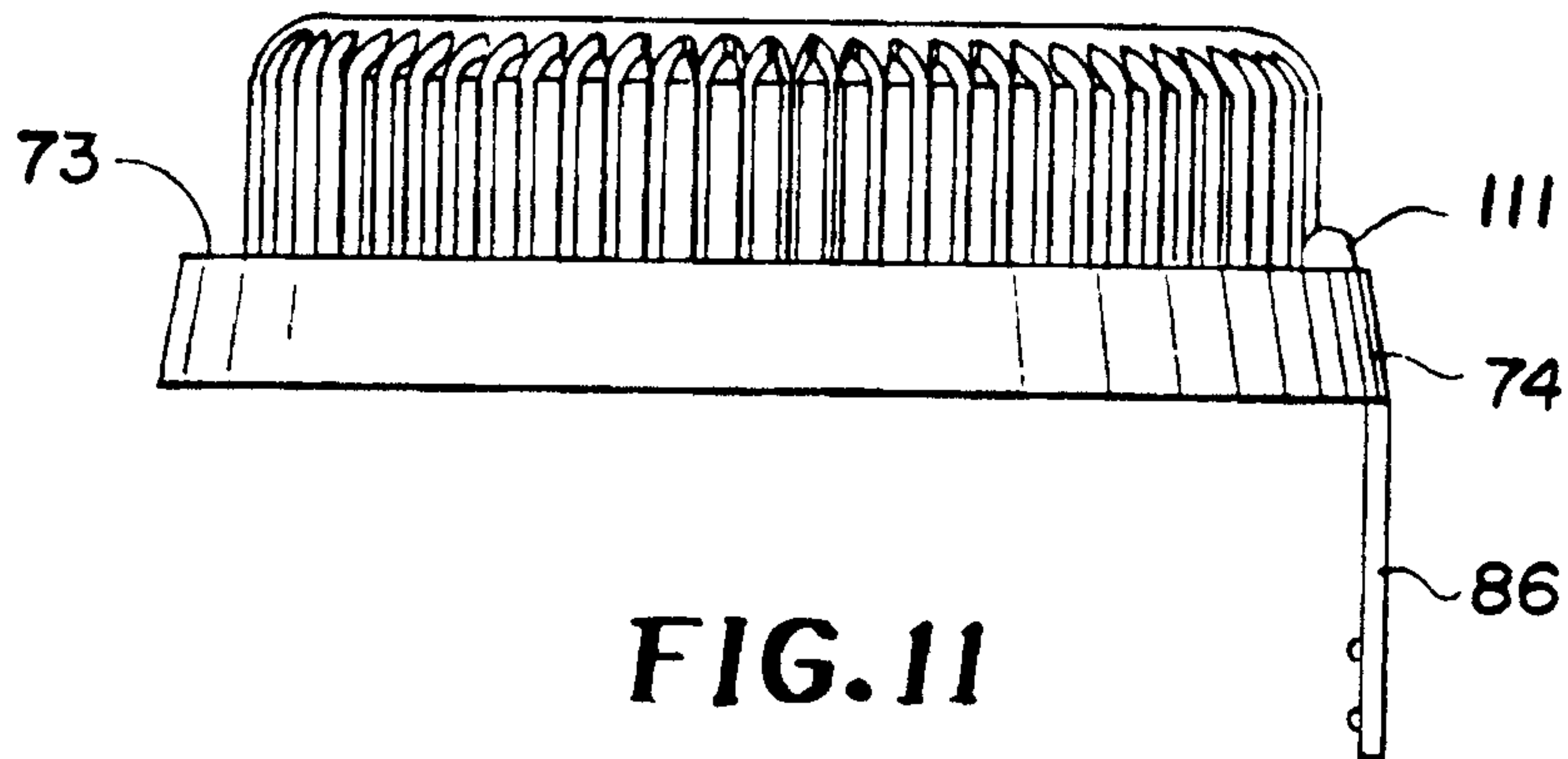

FIG. 11

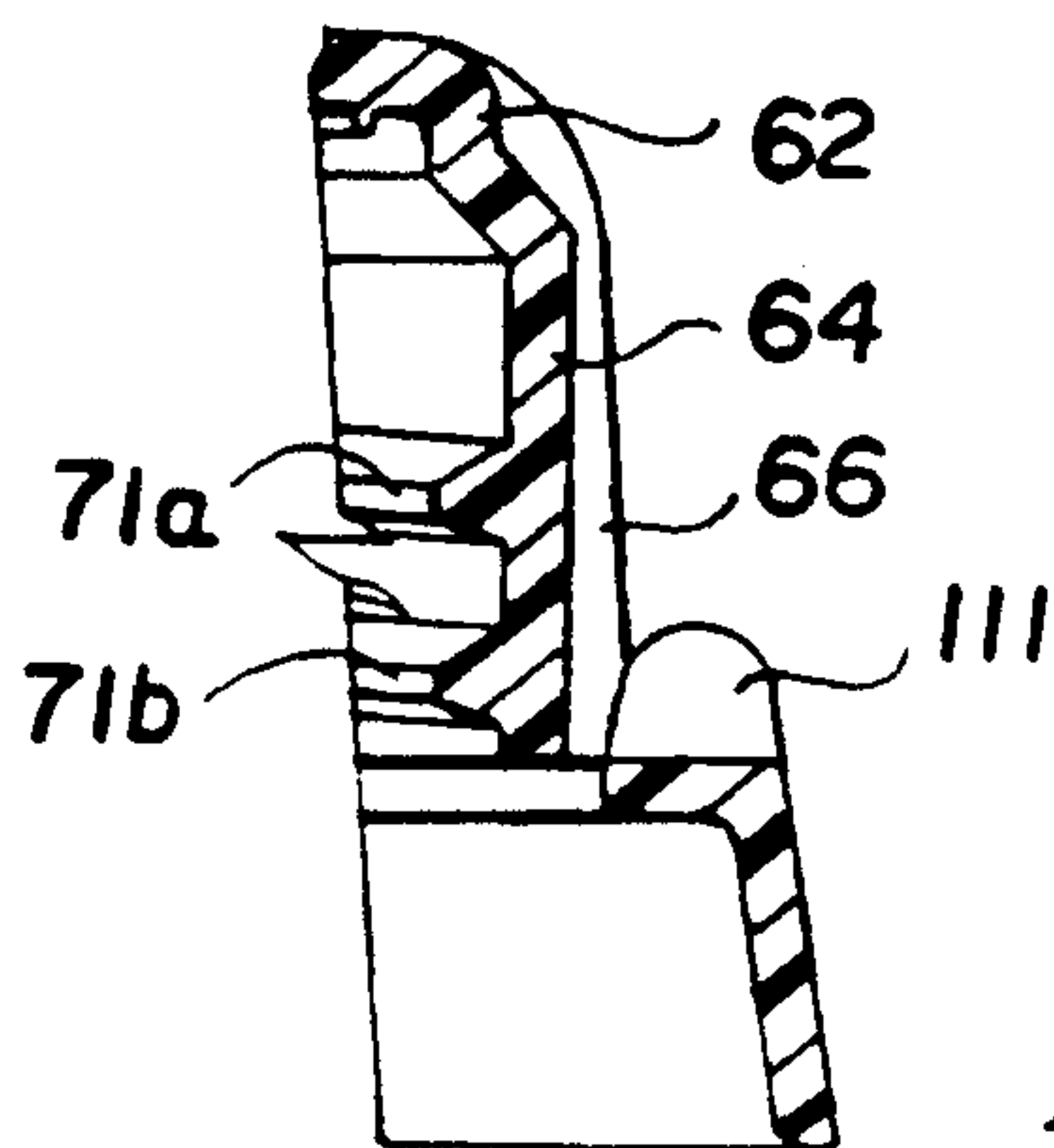

FIG. 12

