



- (51) International Patent Classification:
B60R 21/015 (2006.01) G05D 1/00 (2006.01)
- (21) International Application Number:
PCT/US2016/060037
- (22) International Filing Date:
2 November 2016 (02.11.2016)
- (25) Filing Language: English
- (26) Publication Language: English
- (30) Priority Data:
14/932,954 4 November 2015 (04.11.2015) US
- (71) Applicant: ZOOX, INC. [US/US]; 2180 Sand Hill Rd.,
2nd Floor, Menlo Park, CA 94025 (US).

- (72) Inventors: KENTLEY, Timothy, David; c/o Zoox, Inc.,
2180 Sand Hill Rd., 2nd Floor, Menlo Park, CA 94025
(US). GAMARA, Rachad, Youssef; c/o Zoox, Inc., 2180
Sand Hill Rd., 2nd Floor, Menlo Park, CA 94025 (US).
BEHERE, Sagar; c/o Zoox, Inc., 2180 Sand Hill Rd., 2nd
Floor, Menlo Park, CA 94025 (US).
- (74) Agents: DIVINE, David, A. et al.; Lee & Hayes, PLLC,
601 W. Riverside Ave, Suite 1400, Spokane, WA 99201
(US).
- (81) Designated States (unless otherwise indicated, for every
kind of national protection available): AE, AG, AL, AM,
AO, AT, AU, AZ, BA, BB, BG, BH, BN, BR, BW, BY,
BZ, CA, CH, CL, CN, CO, CR, CU, CZ, DE, DJ, DK, DM,
DO, DZ, EC, EE, EG, ES, FI, GB, GD, GE, GH, GM, GT,
HN, HR, HU, ID, IL, IN, IR, IS, JP, KE, KG, KN, KP, KR,
KW, KZ, LA, LC, LK, LR, LS, LU, LY, MA, MD, ME,
MG, MK, MN, MW, MX, MY, MZ, NA, NG, NI, NO, NZ,
OM, PA, PE, PG, PH, PL, PT, QA, RO, RS, RU, RW, SA,
SC, SD, SE, SG, SK, SL, SM, ST, SV, SY, TH, TJ, TM,

[Continued on next page]

(54) Title: INTERNAL SAFETY SYSTEMS FOR ROBOTIC VEHICLES

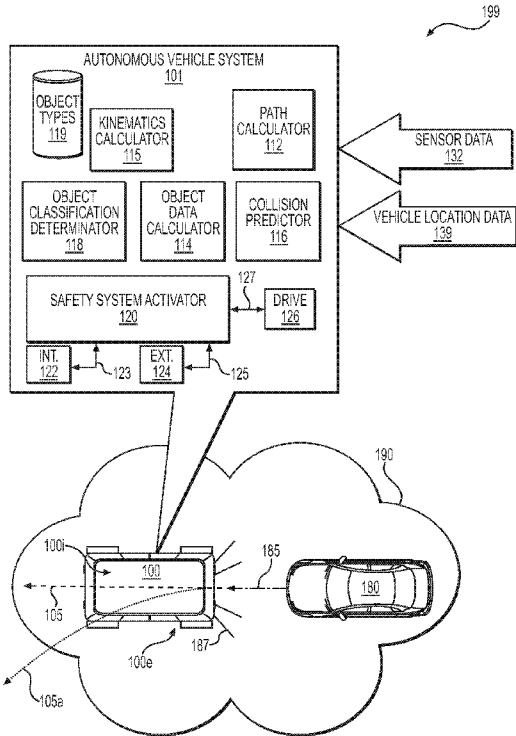

FIG. 1

(57) Abstract: Systems, apparatus and methods implemented in algorithms, hardware, software, firmware, logic, or circuitry may be configured to process data and sensory input to determine whether an object external to an autonomous vehicle (e.g., another vehicle, a pedestrian, road debris, a bicyclist, etc.) may be a potential collision threat to the autonomous vehicle. The autonomous vehicle may be configured to implement interior active safety systems to protect passengers of the autonomous vehicle during a collision with an object or during evasive maneuvers by the autonomous vehicle, for example. The interior active safety systems may be configured to provide passengers with notice of an impending collision and/or emergency maneuvers by the vehicle by tensioning seat belts prior to executing an evasive maneuver and/or prior to a predicted point of collision.

WO 2017/079236 A2

TN, TR, TT, TZ, UA, UG, US, UZ, VC, VN, ZA, ZM, ZW.

LU, LV, MC, MK, MT, NL, NO, PL, PT, RO, RS, SE, SI, SK, SM, TR), OAPI (BF, BJ, CF, CG, CI, CM, GA, GN, GQ, GW, KM, ML, MR, NE, SN, TD, TG).

(84) Designated States (*unless otherwise indicated, for every kind of regional protection available*): ARIPO (BW, GH, GM, KE, LR, LS, MW, MZ, NA, RW, SD, SL, ST, SZ, TZ, UG, ZM, ZW), Eurasian (AM, AZ, BY, KG, KZ, RU, TJ, TM), European (AL, AT, BE, BG, CH, CY, CZ, DE, DK, EE, ES, FI, FR, GB, GR, HR, HU, IE, IS, IT, LT,

Published:

— *without international search report and to be republished upon receipt of that report (Rule 48.2(g))*

INTERNAL SAFETY SYSTEMS FOR ROBOTIC VEHICLES

CROSS-REFERENCE TO RELATED APPLICATIONS

[0001] This PCT international application is a continuation of U.S. Application No. 14/932,954, filed November 4, 2015, which is related to US. Patent Application No. 14/932,959 filed November 4, 2015 entitled "Autonomous Vehicle Fleet Service and System," US. Patent Application No. 14/932,963 filed November 4, 2015, entitled "Adaptive Mapping to Navigate Autonomous Vehicles Responsive to Physical Environment Changes," and US. Patent Application No. 14/932,962 filed November 4, 2015, entitled "Robotic Vehicle Active Safety Systems and Methods," all of which are hereby incorporated by reference in their entirety for all purposes.

FIELD

[0002] Embodiments of the present application relate generally to methods, systems and apparatus for safety systems in robotic vehicles.

BACKGROUND

[0003] Autonomous vehicles, such as the type designed to transport passengers, for example, may be designed to autonomously navigate a computed trajectory (e.g., a computed path). One operational objective of the autonomous vehicle should be to avoid collisions with other vehicles, pedestrians or other obstacles that may be encountered during operation of the autonomous vehicle. However, the autonomous vehicle may share the road with other vehicles, pedestrians and other obstacles which may by their actions create situations that may result in a potential collision with the autonomous vehicle or otherwise threaten the safety of passengers in the autonomous vehicle. As one example, passengers riding in an autonomous vehicle may be unaware of an impending collision or an unexpected maneuver by the vehicle, and may be harmed or unduly alarmed if not provided with some advance notice of a sudden change in the operational status of the vehicle.

[0004] Accordingly, there is a need for systems and methods to implement internal safety systems in an autonomous vehicle.

BRIEF DESCRIPTION OF THE DRAWINGS

[0005] Various embodiments or examples ("examples") are disclosed in the following detailed description and the accompanying drawings:

[0006] FIG. 1 depicts one example of a system for implementing an active safety system in an autonomous vehicle;

[0007] FIG. 2A depicts one example of a flow diagram for implementing an active safety system in an autonomous vehicle;

[0008] FIG. 2B depicts another example of a flow diagram for implementing an active safety system in an autonomous vehicle;

[0009] FIG. 2C depicts yet another example of a flow diagram for implementing an active safety system in an autonomous vehicle;

[0010] FIG. 3A depicts one example of a system for implementing an active safety system in an autonomous vehicle;

[0011] FIG. 3B depicts another example of a system for implementing an active safety system in an autonomous vehicle;

[0012] FIG. 4 depicts one example of a flow diagram for implementing a perception system in an autonomous vehicle;

[0013] FIG. 5 depicts one example of object prioritization by a planner system in an autonomous vehicle;

[0014] FIG. 6 depicts a top plan view of one example of threshold locations and associated escalating alerts in an active safety system in an autonomous vehicle;

[0015] FIG. 7 depicts one example of a flow diagram for implementing a planner system in an autonomous vehicle;

[0016] FIG. 8 depicts one example of a block diagram of systems in an autonomous vehicle;

[0017] FIG. 9 depicts a top view of one example of an acoustic beam-steering array in an exterior safety system of an autonomous vehicle;

[0018] FIG. 10A depicts top plan views of two examples of sensor coverage;

[0019] FIG. 10B depicts top plan views of another two examples of sensor coverage;

[0020] FIG. 11A depicts one example of an acoustic beam-steering array in an exterior safety system of an autonomous vehicle;

[0021] FIG. 11B depicts one example of a flow diagram for implementing acoustic beam-steering in an autonomous vehicle;

[0022] FIG. 11C depicts a top plan view of one example of an autonomous vehicle steering acoustic energy associated with an acoustic alert to an object;

[0023] FIG. 12A depicts one example of a light emitter in an exterior safety system of an autonomous vehicle;

[0024] FIG. 12B depicts profile views of examples of light emitters in an exterior safety system of an autonomous vehicle;

[0025] FIG. 12C depicts a top plan view of one example of light emitter activation based on an orientation of an autonomous vehicle relative to an object;

[0026] FIG. 12D depicts a profile view of one example of light emitter activation based on an orientation of an autonomous vehicle relative to an object;

[0027] FIG. 12E depicts one example of a flow diagram for implementing a visual alert from a light emitter in an autonomous vehicle;

[0028] FIG. 12F depicts a top plan view of one example of a light emitter of an autonomous vehicle emitting light to implement a visual alert;

[0029] FIG. 13A depicts one example of a bladder system in an exterior safety system of an autonomous vehicle;

[0030] FIG. 13B depicts examples of bladders in an exterior safety system of an autonomous vehicle;

[0031] FIG. 13C depicts examples of bladder deployment in an autonomous vehicle;

[0032] FIG. 14 depicts one example of a seat belt tensioning system in an interior safety system of an autonomous vehicle;

[0033] FIG. 15 depicts one example of a seat actuator system in an interior safety system of an autonomous vehicle;

[0034] FIG. 16A depicts one example of a drive system in an autonomous vehicle;

[0035] FIG. 16B depicts one example of obstacle avoidance maneuvering in an autonomous vehicle; and

[0036] FIG. 16C depicts another example of obstacle avoidance maneuvering in an autonomous vehicle;

[0037] FIG. 17 depicts a top plan view of an example of an interior of an autonomous vehicle;

[0038] FIG. 18 depicts a top plan view of another example of an interior of an autonomous vehicle;

[0039] FIG. 19 depicts a cross-sectional view of an example of a seat in an autonomous vehicle;

[0040] FIG. 20 depicts a top plan view of an example of a seat coupler and a passive seat actuator of an autonomous vehicle;

[0041] FIG. 21 depicts a top plan view of an example of a seat coupler and an active seat actuator of an autonomous vehicle;

[0042] FIG. 22 depicts one example of a seat belt tensioner in an interior safety system of an autonomous vehicle;

[0043] FIG. 23 depicts an example of point of impact preference maneuvering in an autonomous vehicle;

[0044] FIG. 24 depicts another example of point of impact preference maneuvering in an autonomous vehicle;

[0045] FIG. 25 depicts an example of a flow diagram for implementing an interior safety system in an autonomous vehicle; and

[0046] FIG. 26 depicts another example of a flow diagram for implementing an interior safety system in an autonomous vehicle.

[0047] Although the above-described drawings depict various examples of the invention, the invention is not limited by the depicted examples. It is to be understood that, in the drawings, like reference numerals designate like structural elements. Also, it is understood that the drawings are not necessarily to scale.

DETAILED DESCRIPTION

[0048] Various embodiments or examples may be implemented in numerous ways, including as a system, a process, a method, an apparatus, a user interface, software, firmware, logic, circuitry, or a series of executable program instructions embodied in a non-transitory computer readable medium. Such as a non-transitory computer readable medium or a computer network where the program instructions are sent over optical, electronic, or wireless communication links and stored or otherwise fixed in a non-transitory computer readable medium. Examples of a non-transitory computer readable medium includes but is not limited to electronic memory, RAM, DRAM, SRAM, ROM, EEPROM, Flash memory, solid-state memory, hard disk drive, and non-volatile memory, for example. One or more non-transitory computer readable mediums may be distributed over a number of devices. In general, operations of disclosed processes may be performed in an arbitrary order, unless otherwise provided in the claims.

[0049] A detailed description of one or more examples is provided below along with accompanying figures. The detailed description is provided in connection with such examples, but is not limited to any particular example. The scope is limited only by the claims and numerous alternatives, modifications, and equivalents are encompassed. Numerous specific details are set forth in the following description in order to provide a thorough understanding. These details are provided for the purpose of example and the described techniques may be practiced according to the claims without some or all of these specific details. For clarity,

technical material that is known in the technical fields related to the examples has not been described in detail to avoid unnecessarily obscuring the description.

[0050] FIG. 1 depicts one example of a system for implementing an active safety system in an autonomous vehicle. In FIG. 1, an autonomous vehicle 100 (depicted in top plan view) may be travelling through an environment 190 external to the autonomous vehicle 100 along a trajectory 105. For purposes of explanation, environment 190 may include one or more objects that may potentially collide with the autonomous vehicle 100, such as static and/or dynamic objects, or objects that pose some other danger to passengers (not shown) riding in the autonomous vehicle 100 and/or to the autonomous vehicle 100. For example, in FIG. 1, an object 180 (e.g., an automobile) is depicted as having a trajectory 185, that if not altered (e.g., by changing trajectory, slowing down, etc.), may result in a potential collision 187 with the autonomous vehicle 100 (e.g., by rear-ending the autonomous vehicle 100).

[0051] Autonomous vehicle 100 may use a sensor system (not shown) to sense (e.g., using passive and/or active sensors) the environment 190 to detect the object 180 and may take action to mitigate or prevent the potential collision of the object 180 with the autonomous vehicle 100. An autonomous vehicle system 101 may receive sensor data 132 from the sensor system and may receive autonomous vehicle location data 139 (e.g., implemented in a localizer system of the autonomous vehicle 100). The sensor data 132 may include but is not limited to data representing a sensor signal (e.g., a signal generated by a sensor of the sensor system). The data representing the sensor signal may be indicative of the environment 190 external to the autonomous vehicle 100. The autonomous vehicle location data 139 may include but is not limited to data representing a location of the autonomous vehicle 100 in the environment 190. As one example, the data representing the location of the autonomous vehicle 100 may include position and orientation data (e.g., a local position or local pose), map data (e.g., from one or more map tiles), data generated by a global positioning system (GPS) and data generated by an inertial measurement unit (IMU). In some examples, a sensor system of the autonomous vehicle 100 may include a global positioning system, an inertial measurement unit, or both.

[0052] Autonomous vehicle system 101 may include but is not limited to hardware, software, firmware, logic, circuitry, computer executable instructions embodied in a non-transitory computer readable medium, or any combination of the foregoing, to implement a path calculator 112, an object data calculator 114 (e.g., implemented in a perception system of the autonomous vehicle 100), a collision predictor 116, an object classification determinator 118 and a kinematics calculator 115. Autonomous vehicle system 101 may access one or more data

stores including but not limited to object types data store 119. Object types data store 119 may include data representing object types associated with object classifications for objects detected in environment 190 (e.g., a variety of pedestrian object types such as "sitting," "standing," or "running," may be associated with objects classified as pedestrians).

[0053] Path calculator 112 may be configured to generate data representing a trajectory of the autonomous vehicle 100 (e.g., trajectory 105), using data representing a location of the autonomous vehicle 100 in the environment 190 and other data (e.g., local pose data included in vehicle location data 139), for example. Path calculator 112 may be configured to generate future trajectories to be executed by the autonomous vehicle 100, for example. In some examples, path calculator 112 may be implanted in or as part of a planner system of the autonomous vehicle 100. In other examples, the path calculator 112 and/or the planner system may calculate data associated with a predicted motion of an object in the environment and may determine a predicted object path associated with the predicted motion of the object. In some examples, the object path may constitute the predicted object path. In other examples, the object path may constitute a predicted object trajectory. In yet other examples, the object path (e.g., in the environment) may constitute a predicted object trajectory that may be identical to or similar to a predicted object trajectory.

[0054] Object data calculator 114 may be configured to calculate data representing the location of the object 180 disposed in the environment 190, data representing an object track associated with the object 180, and data representing an object classification associated with the object 180, and the like. Object data calculator 114 may calculate the data representing the location of the object, the data representing the object track, and the data representing the object classification using data representing a sensor signal included in sensor data 132, for example. In some examples, the object data calculator 114 may be implemented in or may constitute a perception system, or a portion thereof, being configured to receive the data representing the sensor signal (e.g., a sensor signal from a sensor system).

[0055] Object classification determinator 118 may be configured to access data representing object types 119 (e.g., a species of an object classification, a subclass of an object classification, or a subset of an object classification) and may be configured to compare the data representing the object track and the data representing the object classification with the data representing the object types 119 to determine data representing an object type (e.g., a species or subclass of the object classification). As one example, a detected object having an object classification of a "car" may have an object type of "sedan", "coupe", "truck" or "school bus". An object type may include additional subclasses or subsets such as a "school bus" that is parked may have an

additional subclass of "static" (e.g. the school bus is not in motion), or an additional subclass of "dynamic" (e.g. the school bus is in motion), for example.

[0056] Collision predictor 116 may be configured to use the data representing the object type, the data representing the trajectory of the object and the data representing the trajectory of the autonomous vehicle to predict a collision (e.g., 187) between the autonomous vehicle 100 and the object 180, for example.

[0057] A kinematics calculator 115 may be configured to compute data representing one or more scalar and/or vector quantities associated with motion of the object 180 in the environment 190, including but not limited to velocity, speed, acceleration, deceleration, momentum, local pose and force, for example. Data from kinematics calculator 115 may be used to compute other data including but not limited to data representing an estimated time to impact between the object 180 and the autonomous vehicle 100 and data representing a distance between the object 180 and the autonomous vehicle 100, for example. In some examples the kinematics calculator 115 may be configured to predict a likelihood that other objects in the environment 190 (e.g. cars, pedestrians, bicycles, motorcycles, etc.) are in an alert or in-control state, versus an un-alert, out-of-control, or drunk state, etc. As one example, the kinematics calculator 115 may be configured estimate a probability that other agents (e.g., drivers or riders of other vehicles) are behaving rationally (e.g., based on motion of the object they are driving or riding), which may dictate behavior of the autonomous vehicle 100, versus behaving irrationally (e.g. based on erratic motion of the object they are riding or driving). Rational or irrational behavior may be inferred based on sensor data received over time that may be used to estimate or predict a future location of the object relative to a current or future trajectory of the autonomous vehicle 100. Consequently, a planner system of the autonomous vehicle 100 may be configured to implement vehicle maneuvers that are extra cautious and/or activate a safety system of the autonomous vehicle 100, for example.

[0058] A safety system activator 120 may be configured to activate one or more safety systems of the autonomous vehicle 100 when a collision is predicted by the collision predictor 116 and/or the occurrence of other safety related events (e.g., an emergency maneuver by the vehicle 100, such as hard braking, sharp acceleration, etc.). Safety system activator 120 may be configured to activate an interior safety system 122, an exterior safety system 124, a drive system 126 (e.g., cause drive system 126 to execute an emergency maneuver to avoid the collision), or any combination of the foregoing. For example, drive system 126 may receive data being configured to cause a steering system (e.g., set a steering angle or a steering vector

for the wheels) and a propulsion system (e.g., power supplied to an electric motor) to alter the trajectory of vehicle 100 from trajectory 105 to a collision avoidance trajectory 105a.

[0059] FIG. 2A depicts one example of a flow diagram 200 for implementing an active safety system in an autonomous vehicle 100. In flow diagram 200, at a stage 202, data representing a trajectory 203 of an autonomous vehicle 100 in an environment external to the autonomous vehicle 100 (e.g., environment 190) may be received (e.g., implemented in a planner system of the autonomous vehicle 100).

[0060] At a stage 204, object data associated with an object (e.g., automobile 180) disposed in the environment (e.g., environment 190) may be calculated. Sensor data 205 may be accessed at the stage 204 to calculate the object data. The object data may include but is not limited to data representing object location in the environment, an object track associated with the object (e.g., static for a non-moving object and dynamic for an object in motion), and an object classification (e.g., a label) associated with the object (e.g., pedestrian, dog, cat, bicycle, motorcycle, automobile, truck, etc.). The stage 204 may output one or more types of data associated with an object, including but not limited to data representing object location 207 in the environment, data representing an object track 209, and data representing an object classification 211.

[0061] At a stage 206 a predicted object path of the object in the environment may be calculated. As one example, the stage 206 may receive the data representing object location 207 and may process that data to generate data representing a predicted object path 213.

[0062] At a stage 208, data representing object types 215 may be accessed, and at a stage 210, data representing an object type 217 may be determined based on the data representing the object track 209, the data representing the object classification 211 and the data representing object types 215. Examples of an object type may include but are not limited to a pedestrian object type having a static object track (e.g., the pedestrian is not in motion), an automobile object type having a dynamic object track (e.g., the automobile is in motion) and an infrastructure object type having a static object track (e.g., a traffic sign, a lane marker, a fire hydrant), etc., just to name a few. The stage 210 may output the data representing object type 217.

[0063] At a stage 212 a collision between the autonomous vehicle and the object may be predicted based on the determined object type 217, the autonomous vehicle trajectory 203 and the predicted object path 213. As one example, a collision may be predicted based in part on the determined object type 217 due to the object having an object track that is dynamic (e.g., the object is in motion in the environment), the trajectory of the object being in potential

conflict with a trajectory of the autonomous vehicle (e.g., the trajectories may intersect or otherwise interfere with each other), and the object having an object classification 211 (e.g., used in computing the object type 217) that indicates the object is a likely collision threat (e.g., the object is classified as an automobile, a skateboarder, a bicyclists, a motorcycle, etc.).

[0064] At a stage 214, a safety system of the autonomous vehicle may be activated when the collision is predicted (e.g., at the stage 212). The stage 214 may activate one or more safety systems of the autonomous vehicle, such as one or more interior safety systems, one or more exterior safety systems, one or more drive systems (e.g., steering, propulsion, braking, etc.) or a combination of the foregoing, for example. The stage 214 may cause (e.g., by communicating data and/or signals) a safety system activator 220 to activate one or more of the safety systems of the autonomous vehicle 100.

[0065] FIG. 2B depicts another example of a flow diagram 250 for implementing an active safety system in an autonomous vehicle 100. In flow diagram 250, at a stage 252, data representing the trajectory 253 of an autonomous vehicle 100 in an environment external to the autonomous vehicle 100 (e.g., environment 190) may be received (e.g., from a planner system of the autonomous vehicle 100).

[0066] At a stage 254, a location of an object in the environment may be determined. Sensor data 255 may be processed (e.g., by a perception system) to determine data representing an object location in the environment 257. Data associated with an object (e.g., object data associated with object 180) in the environment (e.g., environment 190) may be determined at the state 254. Sensor data 255 accessed at the stage 254 may be used to determine the object data. The object data may include but is not limited to data representing a location of the object in the environment, an object track associated with the object (e.g., static for a non-moving object and dynamic for an object in motion), an object classification associated with the object (e.g., pedestrian, dog, cat, bicycle, motorcycle, automobile, truck, etc.) and an object type associated with the object. The stage 254 may output one or more types of data associated with an object, including but not limited to data representing the object location 257 in the environment, data representing an object track 261 associated with the object, data representing an object classification 263 associated with the object, and data representing an object type 259 associated with the object.

[0067] At a stage 256 a predicted object path of the object in the environment may be calculated. As one example, the stage 256 may receive the data representing the object location 257 and may process that data to generate data representing a predicted object path 265. In some examples, the data representing the predicted object path 265, generated at the stage 256,

may be used as a data input at another stage of flow diagram 250, such as at a stage 258. In other examples, the stage 256 may be bypassed and flow diagram 250 may transition from the stage 254 to the stage 258.

[0068] At the stage 258 a collision between the autonomous vehicle and the object may be predicted based the autonomous vehicle trajectory 253 and the object location 265. The object location 257 may change from a first location to a next location due to motion of the object in the environment. For example, at different points in time, the object may be in motion (e.g., has an object track of dynamic "D"), may be motionless (e.g., has an object track of static "S"), or both. However, the perception system may continually track the object (e.g., using sensor data from the sensor system) during those different points in time to determine object location 257 at the different point in times. Due to changes in a direction of motion of the object and/or the object switching between being in motion and being motionless, the predicted object path 265 calculated at the stage 256 may be difficult to determine; therefore the predicted object path 265 need not be used as a data input at the stage 258.

[0069] The stage 258 may predict the collision using data not depicted in FIG. 2B, such as object type 259 and predicted object path 265, for example. As a first example, at the stage 258, a collision between the autonomous vehicle and the object may be predicted based on the autonomous vehicle trajectory 253, the object location 257 and the object type 259. As second example, at the stage 258, a collision between the autonomous vehicle and the object may be predicted based on the autonomous vehicle trajectory 253 and the predicted object path 265. As a third example, at the stage 258, a collision between the autonomous vehicle and the object may be predicted based on the autonomous vehicle trajectory 253, the predicted object path 265 and the object type 259.

[0070] At a stage 260, a safety system of the autonomous vehicle may be activated when the collision is predicted (e.g., at the stage 258). The stage 260 may activate one or more safety systems of the autonomous vehicle, such as one or more interior safety systems, one or more exterior safety systems, one or more drive systems (e.g., steering, propulsion, braking, etc.) or a combination of the foregoing, for example. The stage 260 may cause (e.g., by communicating data and/or signals) a safety system activator 269 to activate one or more of the safety systems of the autonomous vehicle.

[0071] FIG. 2C depicts yet another example of a flow diagram 270 for implementing an active safety system in an autonomous vehicle. At a stage 272, data representing the trajectory 273 of an autonomous vehicle 100 in an environment external to the autonomous vehicle 100 (e.g.,

environment 190) may be received (e.g., from a planner system of the autonomous vehicle 100).

[0072] At a stage 274 a location of an object in the environment may be determined (e.g., by a perception system) using sensor data 275, for example. The stage 274 may generate data representing object location 279. The data representing the object location 279 may include data representing a predicted rate of motion 281 of the object relative to the location of the object in the environment. For example, if the object has a static object track indicative of no motion in the environment, then the predictive rate of motion 281 may be zero. However, if the object track of the object is dynamic and the object classification is an automobile, then the predicted rate of motion 281 may be non-zero.

[0073] At a stage 276 a predicted next location of the object in the environment may be calculated based on the predicted rate of motion 281. The stage 276 may generate data representing the predicted next location 283.

[0074] At a stage 278, probabilities of impact between the object and the autonomous vehicle may be predicted based on the predicted next location 283 and the autonomous vehicle trajectory 273. The stage 278 may generate data representing the probabilities of impact 285.

[0075] At a stage 280, subsets of thresholds (e.g., a location or a distance in the environment) to activate different escalating functions of subsets of safety systems of the autonomous vehicle may be calculated based on the probabilities of impact 285. At least one subset of the thresholds being associated with the activation of different escalating functions of a safety system of the autonomous vehicle. The stage 280 may generate data representing one or more threshold subsets 287. In some examples, the subsets of thresholds may constitute a location relative to the autonomous vehicle or may constitute a distance relative to the autonomous vehicle. For example, a threshold may be a function of a location or a range of locations relative to a reference location (e.g., the autonomous vehicle). Further, a threshold may be a function of distance relative to an object and the autonomous vehicle, or between any objects or object locations, including distances between predicted object locations.

[0076] At a stage 282, one or more of the different escalating functions of the safety system may be activated based on an associated predicted probability (e.g., activation of a bladder based on a predicted set of probabilities of impact indicative of an eminent collision). The stage 282 may cause (e.g., by communicating data and/or signals) a safety system activator 289 to activate one or more of the safety systems of the autonomous vehicle based on corresponding one or more sets of probabilities of collision.

[0077] FIG. 3A depicts one example 300 of a system for implementing an active safety system in an autonomous vehicle. In FIG. 3A, autonomous vehicle system 301 may include a sensor system 320 including sensors 328 being configured to sense the environment 390 (e.g., in real-time or in near-real-time) and generate (e.g., in real-time) sensor data 332 and 334 (e.g., data representing a sensor signal).

[0078] Autonomous vehicle system 301 may include a perception system 340 being configured to detect objects in environment 390, determine an object track for objects, classify objects, track locations of objects in environment 390, and detect specific types of objects in environment 390, such as traffic signs/lights, road markings, lane markings and the like, for example. Perception system 340 may receive the sensor data 334 from a sensor system 320.

[0079] Autonomous vehicle system 301 may include a localizer system 330 being configured to determine a location of the autonomous vehicle in the environment 390. Localizer system 330 may receive sensor data 332 from a sensor system 320. In some examples, sensor data 332 received by localizer system 330 may not be identical to the sensor data 334 received by the perception system 340. For example, perception system 330 may receive data 334 from sensors including but not limited to LIDAR (e.g., 2D, 3D, color LIDAR), RADAR, and Cameras (e.g., image capture devices); whereas, localizer system 330 may receive data 332 including but not limited to global positioning system (GPS) data, inertial measurement unit (IMU) data, map data, route data, Route Network Definition File (RNDF) data and map tile data. Localizer system 330 may receive data from sources other than sensor system 320, such as a data store, data repository, memory, etc. In other examples, sensor data 332 received by localizer system 330 may be identical to the sensor data 334 received by the perception system 340. In various examples, localizer system 330 and perception system 340 may not implement similar or equivalent sensors or types of sensors. Further, localizer system 330 and perception system 340 each may implement any type of sensor data 332 independently of each other.

[0080] Perception system 340 may process sensor data 334 to generate object data 349 that may be received by a planner system 310. Object data 349 may include data associated with objects detected in environment 390 and the data may include but is not limited to data representing object classification, object type, object track, object location, predicted object path, predicted object trajectory, and object velocity, for example.

[0081] Localizer system 330 may process sensor data 334, and optionally, other data, to generate position and orientation data, local pose data 339 that may be received by the planner system 310. The local pose data 339 may include, but is not limited to, data representing a location of the autonomous vehicle in the environment 390, GPS data, IMU data, map data,

route data, Route Network Definition File (RNDF) data, odometry data, wheel encoder data, and map tile data, for example.

[0082] Planner system 310 may process the object data 349 and the local pose data 339 to compute a path (e.g., a trajectory of the autonomous vehicle) for the autonomous vehicle through the environment 390. The computed path being determined in part by objects in the environment 390 that may create an obstacle to the autonomous vehicle and/or may pose a collision threat to the autonomous vehicle, for example.

[0083] Planner system 310 may be configured to communicate control and data 317 with one or more vehicle controllers 350. Control and data 317 may include information configured to control driving operations of the autonomous vehicle (e.g., steering, braking, propulsion, signaling, etc.) via a drive system 326, to activate one or more interior safety systems 322 of the autonomous vehicle and to activate one or more exterior safety systems 324 of the autonomous vehicle. Drive system 326 may perform additional functions associated with active safety of the autonomous vehicle, such as collision avoidance maneuvers, for example.

[0084] Vehicle controller(s) 350 may be configured to receive the control and data 317, and based on the control and data 317, communicate interior data 323, exterior data 325 and drive data 327 to the interior safety system 322, the exterior safety system 324, and the drive system 326, respectively, as determined by the control and data 317, for example. As one example, if planner system 310 determines that the interior safety system 322 is to be activated based on some action of an object in environment 390, then control and data 317 may include information configured to cause the vehicle controller 350 to generate interior data 323 to activate one or more functions of the interior safety system 322.

[0085] The autonomous vehicle system 301 and its associated systems 310, 320, 330, 340, 350, 322, 324 and 326 may be configured to access data 315 from a data store 311 (e.g., a data repository) and/or data 312 from an external resource 313 (e.g., the Cloud, the Internet, a wireless network). The autonomous vehicle system 301 and its associated systems 310, 320, 330, 340, 350, 322, 324 and 326 may be configured to access, in real-time, data from a variety of systems and/or data sources including but not limited to those depicted in FIG. 3A. As one example, localizer system 330 and perception system 340 may be configured to access in real-time the sensor data 332 and the sensor data 334. As another example, the planner system 310 may be configured to access in real-time the object data 349, the local pose data 339 and control and data 317. In other examples, the planner system 310 may be configured to access in real-time the data store 311 and/or the external resource 313.

[0086] FIG. 3B depicts another example 399 of a system for implementing an active safety system in an autonomous vehicle. In example 399, sensors 328 in sensor system 320 may include but are not limited to one or more of: Light Detection and Ranging sensors 371 (LIDAR); image capture sensors 373 (e.g., Cameras); Radio Detection And Ranging sensors 375 (RADAR); sound capture sensors 377 (e.g., Microphones); Global Positioning System sensors (GPS) and/or Inertial Measurement Unit sensors (IMU) 379; and Environmental sensor(s) 372 (e.g., temperature, barometric pressure), for example. Localizer system 330 and perception system 340 may receive sensor data 332 and/or sensor data 334, respectively, from one or more of the sensors 328. For example, perception system 340 may receive sensor data 334 relevant to determine information associated with objects in environment 390, such as sensor data from LIDAR 371, Cameras 373, RADAR 375, Environmental 372, and Microphones 377; whereas, localizer system 330 may receive sensor data 332 associated with the location of the autonomous vehicle in environment 390, such as from GPS/IMU 379. Further, localizer system 330 may receive data from sources other than the sensor system 320, such as map data, map tile data, route data, Route Network Definition File (RNDF) data, a data store, a data repository, etc., for example. In some examples, sensor data (332, 334) received by localizer system 330 may be identical to the sensor data (332, 334) received by the perception system 340. In other examples, sensor data (332, 334) received by localizer system 330 may not be identical to the sensor data (332, 334) received by the perception system 340. Sensor data 332 and 334 each may include data from any combination of one or more sensors or sensor types in sensor system 320. The amounts and types of sensor data 332 and 334 may be independent from the other and may or may not be similar or equivalent.

[0087] As one example, localizer system 330 may receive and/or access data from sources other than sensor data (332, 334) such as odometry data 336 from motion sensors to estimate a change in position of the autonomous vehicle 100 over time, wheel encoders 337 to calculate motion, distance and other metrics of the autonomous vehicle 100 based on wheel rotations (e.g., by propulsion system 368), map data 335 from data representing map tiles, route data, Route Network Definition File (RNDF) data and/or others, and data representing an autonomous vehicle (AV) model 338 that may be used to calculate vehicle location data based on models of vehicle dynamics (e.g., from simulations, captured data, etc.) of the autonomous vehicle 100. Localizer system 330 may use one or more of the data resources depicted to generate data representing local pose data 339.

[0088] As another example, perception system 340 may parse or otherwise analyze, process, or manipulate sensor data (332, 334) to implement object detection 341, object track 343 (e.g.,

determining which detected objects are static (no motion) and which are dynamic (in motion)), object classification 345 (e.g., cars, motorcycle, bike, pedestrian, skate boarder, mailbox, buildings, street lights, etc.), object tracking 347 (e.g., tracking an object based on changes in a location of the object in the environment 390), and traffic light/sign detection 342 (e.g., stop lights, stop signs, rail road crossings, lane markers, pedestrian cross-walks, etc.).

[0089] As yet another example, planner system 310 may receive the local pose data 339 and the object data 349 and may parse or otherwise analyze, process, or manipulate data (local pose data 339, object data 349) to implement functions including but not limited to trajectory calculation 381, threshold location estimation 386, audio signal selection 389, light pattern selection 382, kinematics calculation 384, object type detection 387, collision prediction 385 and object data calculation 383, for example. Planner system 310 may communicate trajectory and control data 317 to a vehicle controller(s) 350. Vehicle controller(s) 350 may process the vehicle control and data 317 to generate drive system data 327, interior safety system data 323 and exterior safety system data 325. Drive system data 327 may be communicated to a drive system 326. Drive system 326 may communicate the drive system data 327 to a braking system 364, a steering system 366, a propulsion system 368, and a signal system 362 (e.g., turn signals, brake signals, headlights, and running lights). For example, drive system data 327 may include steering angle data for steering system 366 (e.g., a steering angle for a wheel), braking data for brake system 364 (e.g., brake force to be applied to a brake pad), and propulsion data (e.g., a voltage, current or power to be applied to a motor) for propulsion system 368. A dashed line 377 may represent a demarcation between a vehicle trajectory processing layer and a vehicle physical execution layer where data processed in the vehicle trajectory processing layer is implemented by one or more of the drive system 326, the interior safety system 322 or the exterior safety system 324. As one example, one or more portions of the interior safety system 322 may be configured to enhance the safety of passengers in the autonomous vehicle 100 in the event of a collision and/or other extreme event (e.g., a collision avoidance maneuver by the autonomous vehicle 100). As another example, one or more portions of the exterior safety system 324 may be configured to reduce impact forces or negative effects of the aforementioned collision and/or extreme event.

[0090] Interior safety system 322 may have systems including but not limited to a seat actuator system 363 and a seat belt tensioning system 361. Exterior safety system 324 may have systems including but not limited to an acoustic array system 365, a light emitter system 367 and a bladder system 369. Drive system 326 may have systems including but not limited to a braking system 364, a signal system 362, a steering system 366 and a propulsion system 368. Systems

in exterior safety system 324 may be configured to interface with the environment 390 by emitting light into the environment 390 using one or more light emitters (not shown) in the light emitter system 367, emitting a steered beam of acoustic energy (e.g., sound) into the environment 390 using one or more acoustic beam-steering arrays (not shown) in the acoustic beam-steering array 365 or by expanding one or more bladders (not shown) in the bladder system 369 from an un-deployed position to a deployed position, or any combination of the foregoing. Further, the acoustic beam-steering array 365 may emit acoustic energy into the environment using transducers, air horns, or resonators, for example. The acoustic energy may be omnidirectional, or may constitute a steered beam, or otherwise focused sound (e.g., a directional acoustic source, a phased array, a parametric array, a large radiator, or ultrasonic source). Accordingly, systems in exterior safety system 324 may be positioned at one or more locations of the autonomous vehicle 100 configured to allow the systems to interface with the environment 390, such as a location associated with an external surface (e.g., 100e in FIG. 1) of the autonomous vehicle 100. Systems in interior safety system 322 may be positioned at one or more locations associated with an interior (e.g., 100i in FIG. 1) of the autonomous vehicle 100 and may be connected with one or more structures of the autonomous vehicle 100, such as a seat, a bench seat, a floor, a rail, a bracket, a pillar, or other structure. The seat belt tensioning system 361 and the seat actuator system 363 may be coupled with one or more structures configured to support mechanical loads that may occur due to a collision, vehicle acceleration, vehicle deceleration, evasive maneuvers, sharp turns, hard braking, etc., for example.

[0091] FIG. 4 depicts one example of a flow diagram 400 for implementing a perception system in an autonomous vehicle. In FIG. 4, sensor data 434 (e.g., generated by one or more sensors in sensor system 420) received by perception system 440 is depicted visually as sensor data 434a - 434c (e.g., LIDAR data, color LIDAR data, 3D LIDAR data). At a stage 402 a determination may be made as to whether or not the sensor data 434 includes data representing a detected object. If a NO branch is taken, then flow diagram 400 may return to the stage 402 to continue analysis of sensor data 434 to detect object in the environment. If a YES branch is taken, then flow diagram 400 may continue to a stage 404 where a determination may be made as to whether or not the data representing the detected object includes data representing a traffic sign or light. If a YES branch is taken, then flow diagram 400 may transition to a stage 406 where the data representing the detected object may be analyzed to classify the type of light/sign object detected, such as a traffic light (e.g., red, yellow, and green) or a stop sign (e.g., based on shape, text and color), for example. Analysis at the stage 406 may include accessing a traffic object data store 424 where examples of data representing traffic

classifications may be compared with the data representing the detected object to generate data representing a traffic classification 407. The stage 406 may then transition to another stage, such as a stage 412. In some examples, the stage 404 may be optional, and the stage 402 may transition to a stage 408.

[0092] If a NO branch is taken from the stage 404, then flow diagram 400 may transition to the stage 408 where the data representing the detected object may be analyzed to determine other object types to be classified. If a YES branch is taken, then flow diagram 400 may transition to a stage 410 where the data representing the detected object may be analyzed to classify the type of object. An object data store 426 may be accessed to compare stored examples of data representing object classifications with the data representing the detected object to generate data representing an object classification 411. The stage 410 may then transition to another stage, such as a stage 412. If a NO branch is taken from the stage 408, then stage 408 may transition to another stage, such as back to the stage 402.

[0093] At the stage 412, object data classified at the stages 406 and/or 410 may be analyzed to determine if the sensor data 434 indicates motion associated with the data representing the detected object. If motion is not indicated, then a NO branch may be taken to a stage 414 where data representing an object track for the detected object may be set to static (S). At a stage 416, data representing a location of the object (e.g., the static object) may be tracked. For example, a stationary object detected at time t_0 may move at a later time t_1 and become a dynamic object. Moreover, the data representing the location of the object may be included in data received by the planner system (e.g., planner system 310 in FIG. 3B). The planner system may use the data representing the location of the object to determine a coordinate of the object (e.g., a coordinate relative to autonomous vehicle 100).

[0094] On the other hand, if motion is indicated in the detected object, a YES branch may be taken to a stage 418 where data representing an object track for the detected object may be set to dynamic (D). At a stage 419, data representing a location of the object (e.g., the dynamic object) may be tracked. The planner system may analyze the data representing the object track and/or the data representing the location of the object to determine if a detected object (static or dynamic) may potentially have a conflicting trajectory with respect to the autonomous vehicle and/or come into too close a proximity of the autonomous vehicle, such that an alert (e.g., from a light emitter and/or from an acoustic beam-steering array) may be used to alter a behavior of the object and/or the person controlling the object.

[0095] At a stage 422, one or more of the data representing the object classification, the data representing the object track, and the data representing the location of the object, may be

included with the object data 449 (e.g., the object data received by the planner system). As one example, sensor data 434a may include data representing an object (e.g., a person riding a skateboard). Stage 402 may detect the object in the sensor data 434a. At the stage 404, it may be determined that the detected object is not a traffic sign/light. The stage 408 may determine that the detected object is of another class and may analyze at a stage 410, based on data accessed from object data store 426, the data representing the object to determine that the classification matches a person riding a skateboard and output data representing the object classification 411. At the stage 412 a determination may be made that the detected object is in motion and at the stage 418 the object track may be set to dynamic (D) and the location of the object may be tracked at the stage 419 (e.g., by continuing to analyze the sensor data 434a for changes in location of the detected object). At the stage 422, the object data associated with sensor data 434 may include the classification (e.g., a person riding a skateboard), the object track (e.g., the object is in motion), the location of the object (e.g., the skateboarder) in the environment external to the autonomous vehicle) and object tracking data for example.

[0096] Similarly, for sensor data 434b, flow diagram 400 may determine that the object classification is a pedestrian, the pedestrian is in motion (e.g., is walking) and has a dynamic object track, and may track the location of the object (e.g., the pedestrian) in the environment, for example. Finally, for sensor data 434c, flow diagram 400 may determine that the object classification is a fire hydrant, the fire hydrant is not moving and has a static object track, and may track the location of the fire hydrant. Note, that in some examples, the object data 449 associated with sensor data 434a, 434b, and 434c may be further processed by the planner system based on factors including but not limited to object track, object classification and location of the object, for example. As one example, in the case of the skateboarder and the pedestrian, the object data 449 may be used for one or more of trajectory calculation, threshold location estimation, motion prediction, location comparison, and object coordinates, in the event the planner system decides to implement an alert (e.g., by an exterior safety system) for the skateboarder and/or the pedestrian. However, the planner system may decide to ignore the object data for the fire hydrant due its static object track because the fire hydrant is not likely to have a motion (e.g., it is stationary) that will conflict with the autonomous vehicle and/or because the fire hydrant is non-animate (e.g., can't respond to or be aware of an alert, such as emitted light and/or beam steered sound), generated by an exterior safety system of the autonomous vehicle), for example.

[0097] FIG. 5 depicts one example 500 of object prioritization by a planner system in an autonomous vehicle. Example 500 depicts a visualization of an environment 590 external to

the autonomous vehicle 100 as sensed by a sensor system of the autonomous vehicle 100 (e.g., sensor system 320 of FIG. 3B). Object data from a perception system of the autonomous vehicle 100 may detect several objects in environment 590 including but not limited to an automobile 581d, a bicycle rider 583d, a walking pedestrian 585d, and two parked automobiles 5875 and 5895. In this example, a perception system may have assigned (e.g., based on sensor data 334 of FIG. 3B) dynamic "D" object tracks to objects 581d, 583d and 585d, thus the label "d" is associated with the reference numerals for those objects. The perception system may also have assigned (e.g., based on sensor data 334 of FIG. 3B) static "S" object tracks to objects 5875 and 5895, thus the label "s" is associated with the reference numerals for those objects.

[0098] A localizer system of the autonomous vehicle may determine the local pose data 539 for a location of the autonomous vehicle 100 in environment 590 (e.g., X, Y, Z coordinates relative to a location on vehicle 100 or other metric or coordinate system). In some examples, the local pose data 539 may be associated with a center of mass (not shown) or other reference point of the autonomous vehicle 100. Furthermore, autonomous vehicle 100 may have a trajectory T_{av} as indicated by the arrow. The two parked automobiles 5875 and 5895 are static and have no indicated trajectory. Bicycle rider 583d has a trajectory T_b that is in a direction approximately opposite that of the trajectory T_{av} , and automobile 581 d has a trajectory T_{mv} that is approximately parallel to and in the same direction as the trajectory T_{av} . Pedestrian 585d has a trajectory T_p that is predicted to intersect the trajectory T_{av} of the vehicle 100. Motion and/or position of the pedestrian 585d in environment 590 or other objects in the environment 590 may be tracked or otherwise determined using metrics other than trajectory, including but not limited to object location, predicted object motion, object coordinates, predictive rate of motion relative to the location of the object, and a predicted next location of the object, for example. Motion and/or position of the pedestrian 585d in environment 590 or other objects in the environment 590 may be determined, at least in part, due to probabilities. The probabilities may be based on data representing object classification, object track, object location, and object type, for example. In some examples, the probabilities may be based on previously observed data for similar objects at a similar location. Further, the probabilities may be influenced as well by time of day or day of the week, or other temporal units, etc. As one example, the planner system may learn that between about 3:00pm and about 4:00pm, on weekdays, pedestrians at a given intersection are 85% likely to cross a street in a particular direction.

[0099] The planner system may place a lower priority on tracking the location of static objects 5875 and 5895 and dynamic object 583d because the static objects 5875 and 5895 are positioned out of the way of trajectory T_{av} (e.g., objects 5875 and 5895 are parked) and

dynamic object 583d (e.g., an object identified as a bicyclist) is moving in a direction away from the autonomous vehicle 100; thereby, reducing or eliminating a possibility that trajectory Tb of object 583d may conflict with trajectory Tav of the autonomous vehicle 100.

[0100] However, the planner system may place a higher priority on tracking the location of pedestrian 585d due to its potentially conflicting trajectory Tp, and may place a slightly lower priority on tracking the location of automobile 581d because its trajectory Tmv is not presently conflicting with trajectory Tav, but it may conflict at a later time (e.g., due to a lane change or other vehicle maneuver). Therefore, based on example 500, pedestrian object 585d may be a likely candidate for an alert (e.g., using steered sound and/or emitted light) or other safety system of the autonomous vehicle 100, because the path of the pedestrian object 585d (e.g., based on its location and/or predicted motion) may result in a potential collision (e.g., at an estimated location 560) with the autonomous vehicle 100 or result in an unsafe distance between the pedestrian object 585d and the autonomous vehicle 100 (e.g., at some future time and/or location). A priority placed by the planner system on tracking locations of objects may be determined, at least in part, on a cost function of trajectory generation in the planner system. Objects that may be predicted to require a change in trajectory of the autonomous vehicle 100 (e.g., to avoid a collision or other extreme event) may be factored into the cost function with greater significance as compared to objects that are predicted to not require a change in trajectory of the autonomous vehicle 100, for example.

[0101] The planner system may predict one or more regions of probable locations 565 of the object 585d in environment 590 based on predicted motion of the object 585d and/or predicted location of the object. The planner system may estimate one or more threshold locations (e.g., threshold boundaries) within each region of probable locations 565. The threshold location may be associated with one or more safety systems of the autonomous vehicle 100. The number, distance and positions of the threshold locations may be different for different safety systems of the autonomous vehicle 100. A safety system of the autonomous vehicle 100 may be activated at a parametric range in which a collision between an object and the autonomous vehicle 100 is predicted. The parametric range may have a location within the region of probable locations (e.g., within 565). The parametric range may be based in part on parameters such as a range of time and/or a range of distances. For example, a range of time and/or a range of distances in which a predicted collision between the object 585d and the autonomous vehicle 100 may occur. In some examples, being a likely candidate for an alert by a safety system of the autonomous vehicle 100 does not automatically result in an actual alert being issued (e.g., as determine by the planner system). In some examples, an object may be a candidate when a

threshold is met or surpassed. In other examples, a safety system of the autonomous vehicle 100 may issue multiple alerts to one or more objects in the environment external to the autonomous vehicle 100. In yet other examples, the autonomous vehicle 100 may not issue an alert even though an object has been determined to be a likely candidate for an alert (e.g., the planner system may have computed an alternative trajectory, a safe-stop trajectory or a safe-stop maneuver that obviates the need to issue an alert).

[0102] FIG. 6 depicts a top plan view of one example 600 of threshold locations and associated escalating alerts in an active safety system in an autonomous vehicle. In FIG. 6, the example 500 of FIG. 5 is further illustrated in top plan view where trajectory T_{av} and T_p are estimated to cross (e.g., based on location data for the vehicle 100 and the pedestrian object 585d) at an estimated location denoted as 560. Pedestrian object 585d is depicted in FIG. 6 based on pedestrian object 585d being a likely candidate for an alert (e.g., visual and/or acoustic) based on its predicted motion. The pedestrian object 585d is depicted having a location that is within the region of probable locations 565 that was estimated by the planner system. Autonomous vehicle 100 may be configured to travel bi-directionally as denoted by arrow 680, that is, autonomous vehicle 100 may not have a front (e.g., a hood) or a back (e.g., a trunk) as in a conventional automobile. Note while FIG. 6 and other figures may describe implementations as applied to bidirectional vehicles, the functions and/or structures need not be so limiting and may be applied to any vehicle, including unidirectional vehicles. Accordingly, sensors of the sensor system and safety systems may be positioned on vehicle 100 to provide sensor and alert coverage in more than one direction of travel of the vehicle 100 and/or to provide sensor and alert coverage for objects that approach the vehicle 100 from its sides 1005 (e.g., one or more sensors 328 in sensor system 330 in FIG. 3B may include overlapping regions of sensor coverage). The planner system may implement a safe-stop maneuver or a safe-stop trajectory using the bi-directional 680 travel capabilities to avoid a collision with an object, for example. As one example, the autonomous vehicle 100 may be traveling in a first direction, come to a stop, and begin travel in a second direction that is opposite the first direction, and may maneuver to a safe-stop location to avoid a collision or other extreme event.

[0103] The planner system may estimate one or more threshold locations (e.g., threshold boundaries, which may be functions of distances, etc.) in the environment 590, denoted as 601, 603 and 605, at which to issue an alert when the location of the object (e.g., pedestrian object 585d) coincides with the threshold locations as denoted by points of coincidence 602, 604 and 606. Although three threshold locations are depicted, there may be more or fewer than depicted. As a first example, as the trajectory T_p crosses the first threshold location 601 at a point denoted

as 602, planner system may determine the location of the pedestrian object 585d at the point 602 (e.g., having coordinates X_1, Y_1 of either a relative or an absolute reference frame) and the coordinates of a location of the autonomous vehicle 100 (e.g., from local pose data). The location data for the autonomous vehicle 100 and the object (e.g., object 585d) may be used to calculate a location (e.g., coordinates, an angle, a polar coordinate) for the direction of propagation (e.g., a direction of the main lobe or focus of the beam) of a beam of steered acoustic energy (e.g., an audio alert) emitted by an acoustic beam-steering array (e.g., one or more of a directional acoustic source, a phased array, a parametric array, a large radiator, a ultrasonic source, etc.), may be used to determine which light emitter to activate for a visual alert, may be used to determine which bladder(s) to activate prior to a predicted collision with an object, and may be used to activate other safety systems and/or the drive system of the autonomous vehicle 100, or any combination of the foregoing. As the autonomous vehicle 100 continues to travel in a direction 625 along trajectory T_{av} , from location L1 to location L2, the relative locations of the pedestrian object 585d and the autonomous vehicle 100 may change, such that at the location L2, the object 585d has coordinates (X_2, Y_2) at point 604 of the second threshold location 603. Similarly, continued travel in the direction 625 along trajectory T_{av} , from location L2 to location L3, may change the relative locations of the pedestrian object 585d and the autonomous vehicle 100, such that at the location L3, the object 585d has coordinates (X_3, Y_3) at point 606 of the third threshold location 605.

[0104] As the distance between the autonomous vehicle 100 and the pedestrian object 585d decreases, the data representing the alert selected for a safety system may be different to convey an increasing sense of urgency (e.g., an escalating threat level) to the pedestrian object 585d to change or halt its trajectory T_p , or otherwise modify his/her behavior to avoid a potential collision or close pass with the vehicle 100. As one example, the data representing the alert selected for threshold location 601, when the vehicle 100 may be at a relatively safe distance from the pedestrian object 585d, may be a less alarming nonthreatening alert a_1 configured to garner the attention of the pedestrian object 585d in a non-threatening manner. As a second example, the data representing the alert selected for threshold location 603, when the vehicle 100 may be at a cautious distance from the pedestrian object 585d, may be a more aggressive urgent alert a_2 configured to gain the attention of the pedestrian object 585d in a more urgent manner. As a third example, the data representing the alert selected for threshold location 605, when the vehicle 100 may be at a potentially un-safe distance from the pedestrian object 585d, may be a very aggressive extremely urgent alert a_3 configured to gain the attention of the pedestrian object 585d in an extremely urgent manner. As the distance between the autonomous

vehicle 100 and the pedestrian object 585d decreases, the data representing the alerts may be configured to convey an increasing escalation of urgency to pedestrian object 585d (e.g., escalating acoustic and/or visual alerts to gain the attention of pedestrian object 585d). Estimation of positions of the threshold locations in the environment 590 may be determined by the planner system to provide adequate time (e.g., approximately 5 seconds or more), based on a velocity of the autonomous vehicle, before the vehicle 100 arrives at a predicted impact point 560 with the pedestrian object 585d (e.g., a point 560 in environment 590 where trajectories T_{av} and T_p are estimated to intersect each other). Point 560 may change as the speed and/or location of the object 585d, the vehicle 100, or both changes. In some examples, in concert with implementing active alerts (e.g., acoustic and/or visual alerts), the planner system of the autonomous vehicle 100 may be configured to actively attempt to avoid potential collisions (e.g., by calculating alternative collision avoidance trajectories and executing one or more of those trajectories) by calculating (e.g., continuously) safe trajectories (e.g., when possible based on context), while simultaneously, issuing alerts as necessary to objects in the environment when there is a meaningful probability the objects may collide or otherwise pose a danger to the safety of passengers in the autonomous vehicle 100, to the object, or both.

[0105] In FIG. 6, trajectory T_p of the pedestrian object 585d need not be a straight line as depicted and the trajectory (e.g., the actual trajectory) may be an arcuate trajectory as depicted in example 650 or may be a non-linear trajectory as depicted in example 670. Points 652, 654 and 656 in example 650 and points 672, 674 and 676 in example 670, depict points where the trajectory T_p intersects threshold locations 651, 653 and 655 and threshold locations 671, 673 and 675, respectively. The planner system may process object data from the perception system and local pose data from the localizer system to calculate the threshold location(s). The location, shape (e.g., linear, arcuate, non-linear), orientation (e.g., with respect to the autonomous vehicle and/or object) and other characteristics of the threshold location may be application dependent and is not limited to the examples depicted herein. For example, in FIG. 6, threshold locations (601, 603 and 605) in example 600 are aligned approximately perpendicular to the trajectory T_p of pedestrian object 585d; however, other configurations and orientations may be calculated and implemented by the planner system (e.g., see examples 650 and 670). As another example, threshold locations may be aligned approximately perpendicular (or other orientation) to the trajectory T_{av} of the autonomous vehicle 100. Furthermore, the trajectory of the object may be analyzed by the planner system to determine the configuration of the threshold location(s). As one example, if the object is on a trajectory that is parallel to

the trajectory of the autonomous vehicle 100, then the threshold location(s) may have an arcuate profile and may be aligned with the trajectory of the object.

[0106] FIG. 7 depicts one example of a flow diagram 700 for implementing a planner system in an autonomous vehicle. In FIG. 7, planner system 710 may be in communication with a perception system 740 from which it receives object data 749, and a localizer system 730 from which it receives local pose data 739. Object data 749 may include data associated with one or more detected objects. For example, in a typical scenario, object data 749 may include data associated with a large number of detected objects in the environment external to the autonomous vehicle 100. However, some detected objects need not be tracked or may be assigned a lower priority based on the type of object. For example, fire hydrant object 434c in FIG. 4 may be a static object (e.g., fixed to the ground) and may not require processing for an alert or activation of other safety systems; whereas, skateboarder object 434a may require processing for an alert (e.g., using emitted light, steered sound or both) due to it being a dynamic object and other factors, such as predicted human behavior of skateboard riders, a location of the skateboarder object 434a in the environment that may indicate the location (e.g., a predicted location) may conflict with a trajectory of the autonomous vehicle 100, for example.

[0107] Further to FIG. 7, an example of three detected objects is denoted as 734a - 734c. There may be object data 749 for more or fewer detected objects as denoted by 734. The object data for each detected object may include but is not limited to data representing: object location 721; object classification 723; and object track 725. Planner system 710 may be configured to implement object type determination 731. Object type determination 731 may be configured to receive the data representing object classification 723, the data representing the object track 725 and data representing object types that may be accessed from an object types data store 724. The object type determination 731 may be configured to compare the data representing the object classification 723 and the data representing the object track 725 with data representing object types (e.g., accessed from data store 724) to determine data representing an object type 733. Examples of data representing an object type 733 may include but are not limited to a static grounded object type (e.g., the fire hydrant 434c of FIG. 4) and a dynamic pedestrian object (e.g., pedestrian object 585d of FIG. 5).

[0108] Object dynamics determination 735 may be configured to receive the data representing the object type 733 and the data representing the object location 721. Object dynamics determination 735 may be further configured to access an object dynamics data store 726. Object dynamics data store 726 may include data representing object dynamics. Object dynamics determination 735 may be configured to compare data representing object dynamics

with the data representing the object type 733 and the data representing the object location 721 to determine data representing a predicted object motion 737.

[0109] Object location predictor 741 may be configured to receive the data representing the predicted object motion 737, the data representing the location of the autonomous vehicle 743 (e.g., from local pose data 739), the data representing the object location 721 and the data representing the object track 725. The object location predictor 741 may be configured to process the received data to generate data representing a predicted object location 745 in the environment. Object location predictor 741 may be configured to generate data representing more than one predicted object location 745. The planner system 710 may generate data representing regions of probable locations (e.g., 565 in FIGS. 5 and 6) of an object.

[0110] Threshold location estimator 747 may be configured to receive the data representing the location of the autonomous vehicle 743 (e.g., from local pose data 739) and the data representing the predicted object location 745 and generate data representing one or more threshold locations 750 in the environment associated with an alert to be triggered (e.g., a visual alert and/or an acoustic alert), or associated with activation of one or more safety systems of vehicle 100, for example. The one or more threshold locations 750 may be located with the regions of probable locations (e.g., 601, 603 and 605 within 565 in FIG. 6).

[0111] FIG. 8 depicts one example 800 of a block diagram of systems in an autonomous vehicle. In FIG. 8, the autonomous vehicle 100 may include a suite of sensors 820 positioned at one or more locations on the autonomous vehicle 100. Each suite 820 may have sensors including but not limited to LIDAR 821 (e.g., color LIDAR, three-dimensional color LIDAR, two-dimensional LIDAR, etc.), an image capture device 823 (e.g., a digital camera), RADAR 825, a microphone 827 (e.g., to capture ambient sound), and a loudspeaker 829 (e.g., to greet/communicate with passengers of the AV 100). Microphones 871 (e.g., to may be configured to capture sound from drive system components such as propulsion systems and/or braking systems) and may be positioned at suitable locations proximate to drive system components to detect sound generated by those components, for example. Each suite of sensors 820 may include more than one of the same types of sensor, such as two image capture devices 823, or microphone 871 positioned proximate to each wheel 852, for example. Microphone 871 may be configured to capture audio signals indicative of drive operations of the autonomous vehicle 100. Microphone 827 may be configured to capture audio signals indicative of ambient sounds in the environment external to the autonomous vehicle 100. Multiple microphones 827 may be paired or otherwise grouped to generate signals that may be processed to estimate sound source location of sounds originating in the environment 890, for

example. Autonomous vehicle 100 may include sensors for generating data representing location of the autonomous vehicle 100, and those sensors may include but are not limited to a global positioning system (GPS) 839a and/or an inertial measurement unit (IMU) 839b. Autonomous vehicle 100 may include one or more sensors ENV 877 for sensing environmental conditions in the environment external to the autonomous vehicle 100, such as air temperature, air pressure, humidity, barometric pressure, etc. Data generated by sensor(s) ENV 877 may be used to calculate the speed of sound in processing of data used by array(s) 102 (see arrays 102 depicted in FIG. 9), such as wave front propagation times, for example. Autonomous vehicle 100 may include one or more sensors MOT 888 configured to detect motion of the vehicle 100 (e.g., motion due to an impact from a collision, motion due to an emergency/evasive maneuvering, etc.). As one example, sensor MOT 888 may include but is not limited to an accelerometer, a multi-axis accelerometer and a gyroscope. Autonomous vehicle 100 may include one or more rotation sensors (not shown) associated with wheels 852 and configured to detect rotation 853 of the wheel 852 (e.g., a wheel encoder). For example, each wheel 852 may have an associated wheel encoder configured to detect rotation of the wheel 852 (e.g., an axle of the wheel 852 and/or a propulsion component of the wheel 852, such as an electric motor, etc.). Data representing a rotation signal generated by the rotation sensor may be received by one or more systems of the autonomous vehicle 100, such as the planner system, the localizer system, the perception system, the drive system, and one or more of the safety systems, for example.

[0112] A communications network 815 may route signals and/or data to/from sensors, one or more safety systems 875 (e.g., a bladder, a seat actuator, a seat belt tensioner), and other components of the autonomous vehicle 100, such as one or more processors 810 and one or more routers 830, for example. Routers 830 may route signals and/or data from: sensors in sensors suites 820, one or more acoustic beam-steering arrays 102 (e.g., one or more of a directional acoustic source, a phased array, a parametric array, a large radiator, of ultrasonic source), one or more light emitters, between other routers 830, between processors 810, drive operation systems such as propulsion (e.g., electric motors 851), steering, braking, one or more safety systems 875, etc., and a communications system 880 (e.g., for wireless communication with external systems and/or resources).

[0113] In FIG. 8, one or more microphones 827 may be configured to capture ambient sound in the environment 890 external to the autonomous vehicle 100. Signals and/or data from microphones 827 may be used to adjust gain values for one or more speakers positioned in one or more of the acoustic beam-steering arrays (not shown). As one example, loud ambient noise,

such as emanating from a construction site may mask or otherwise impair audibility of the beam of steered acoustic energy 104 being emitted by an acoustic beam-steering array. Accordingly, the gain may be increased or decreased based on ambient sound (e.g., in dB or other metric such as frequency content).

[0114] Microphones 871 may be positioned in proximity of drive system components, such as electric motors 851, wheels 852, or brakes (not shown) to capture sound generated by those systems, such as noise from rotation 853, regenerative braking noise, tire noise, and electric motor noise, for example. Signals and/or data generated by microphones 871 may be used as the data representing the audio signal associated with an audio alert, for example. In other examples, signals and/or data generated by microphones 871 may be used to modulate the data representing the audio signal. As one example, the data representing the audio signal may constitute an audio recording (e.g., a digital audio file) and the signals and/or data generated by microphones 871 may be used to modulate the data representing the audio signal. Further to the example, the signals and/or data generated by microphones 871 may be indicative of a velocity of the vehicle 100 and as the vehicle 100 slows to a stop at a pedestrian cross-walk, the data representing the audio signal may be modulated by changes in the signals and/or data generated by microphones 871 as the velocity of the vehicle 100 changes. In another example, the signals and/or data generated by microphones 871 that are indicative of the velocity of the vehicle 100 may be used as the data representing the audio signal and as the velocity of the vehicle 100 changes, the sound being emitted by the acoustic beam-steering array 102 may be indicative of the change in velocity of the vehicle 100. As such, the sound (or acoustic energy magnitude) may be changed (e.g., in volume, frequency, etc.) based on velocity changes. The above examples may be implemented to audibly notify pedestrians that the autonomous vehicle 100 has detected their presence at the cross-walk and is slowing to a stop.

[0115] One or more processors 810 may be used to implement one or more of the planner system, the localizer system, the perception system, one or more safety systems, and other systems of the vehicle 100, for example. One or more processors 810 may be configured to execute algorithms embodied in a non-transitory computer readable medium, to implement one or more of the planner system, the localizer system, the perception system, one or more safety systems, or other systems of the vehicle 100, for example. The one or more processors 810 may include but are not limited to circuitry, logic, field programmable gate array (FPGA), application specific integrated circuits (ASIC), programmable logic, a digital signal processor (DSP), a graphics processing unit (GPU), a microprocessor, a microcontroller, a big fat computer (BFC) or others, or clusters thereof.

[0116] FIG. 9 depicts a top view of one example 900 of an acoustic beam-steering array in an exterior safety system of an autonomous vehicle. In FIG. 9, sensor suites (e.g., 820 in FIG. 8) may be positioned at corner portions of the autonomous vehicle 100 (e.g., a pillar section) and enclosures for acoustic beam-steering arrays 102 may be positioned on an upper surface 100u (e.g., on a roof or other locations on the vehicle) of the autonomous vehicle 100 and may be positioned to direct their respective beams of steered acoustic energy 104 (e.g., see FIG. 11) outward into the environment towards a location of an object targeted to receive an acoustic alert. Acoustic beam-steering arrays 102 (e.g., a directional acoustic source, a phased array, a parametric array, a large radiator, of ultrasonic source) may be configured to provide coverage of steered acoustic energy at one or more objects disposed in the environment external to the autonomous vehicle 100 and the coverage may be in an arc of about 360 degrees around the autonomous vehicle 100, for example. The acoustic beam-steering arrays 102 need not be the same size, shape, or have the same number of speakers. The acoustic beam-steering arrays 102 need not be linear as depicted in FIG. 9. Further to FIG. 9, acoustic beam-steering arrays 102 denoted as C and D have different dimensions than acoustic beam-steering arrays 102 denoted as A and B. Sensor suites 820 may be positioned to provide sensor coverage of the environment external to the autonomous vehicle 100 for one acoustic beam-steering array 102 or multiple acoustic beam-steering arrays 102. In the case of multiple acoustic beam-steering arrays 102, the sensor suites 820 may provide overlapping regions of sensor coverage. A perception system of the autonomous vehicle 100 may receive sensor data from more than one sensor or suite of sensors to provide data for the planning system to implement activation of one or more of the arrays 102 to generate an acoustic alert and/or to activate one or more other safety systems of vehicle 100, for example. The autonomous vehicle 100 may not have a front (e.g., a hood) or a rear (e.g., a trunk) and therefore may be configured for driving operations in at least two different directions as denoted by arrow 980. Accordingly, the acoustic beam-steering arrays 102 may not have a front or rear designation and depending on which direction the autonomous vehicle 100 is driving in, array 102 (A) may be the array facing the direction of travel or array 102 (B) may be the array facing the direction of travel.

[0117] Other safety systems of the autonomous vehicle 100 may be disposed at interior 100i (shown in dashed line) and exterior 100e locations on the autonomous vehicle 100 and may be activated for generating alerts or other safety functions by the planner system using the sensor data from the sensor suites. The overlapping regions of sensor coverage may be used by the planner system to activate one or more safety systems in response to multiple objects in the environment that may be positioned at locations around the autonomous vehicle 100.

[0118] FIGS. 10A - 10B depicts top plan views of examples of sensor coverage. In example 1010 of FIG. 10A, one of the four sensor suites 820 (denoted in underline) may provide sensor coverage 1011, using one or more of its respective sensors, of the environment 1090 in a coverage region that may be configured to provide sensor data for one or more systems, such as a perception system, localizer system, planner system and safety systems of the autonomous vehicle 100, for example. In the top plan view of FIG. 10A, arrows A, B, C and D demarcate four quadrants 1 - 4 that surround the autonomous vehicle 100. In example 1010, sensor coverage 1011 by a single suite 820 may be partial sensor coverage because there may be partial sensor blind spots not covered by the single suite 820 in quadrants 1, 3 and 4, and full sensor coverage in quadrant 2.

[0119] In example 1020, a second of the four sensor suites 820 may provide sensor coverage 1021 that overlaps with sensor coverage 1011, such that there may be partial sensor coverage in quadrants 1 and 4 and full sensor coverage in quadrants 2 and 3. In FIG. 10B, in example 1030, a third of the four sensor suites 820 may provide sensor coverage 1031 that overlaps with sensor coverage 1011 and 1021, such that quadrants 2, 3 and 4 have full sensor coverage and quadrant 1 has partial coverage. Finally, in example 1040, a fourth of the four sensor suites 820 (e.g., all four sensor suites are on-line) may provide sensor coverage 1041 that overlaps with sensor coverage 1011, 1021 and 1031, such that quadrants 1 - 4 have full coverage. The overlapping sensor regions of coverage may allow for redundancy in sensor coverage if one or more sensor suites 820 and/or one or more of their respective sensors (e.g., LIDAR, Camera, RADAR, etc.) are damaged, malfunction, or are otherwise rendered inoperative. One or more of the sensor coverage patterns 1011, 1021, 1031 and 1041 may allow the planner system to implement activation of one or more safety systems based on the position of those safety systems on the autonomous vehicle 100. As one example, bladders of a bladder safety system positioned on a side of the autonomous vehicle 100 (e.g., the side of the vehicle 100 with arrow C) may be activated to counter a collision from an object approaching the vehicle 100 from the side.

[0120] FIG. 11A depicts one example of an acoustic beam-steering array in an exterior safety system of an autonomous vehicle. In FIG. 11A, control data 317 from planner system 310 may be communicated to vehicle controller 350 which may in turn communicate exterior data 325 being configured to implement an acoustic alert by acoustic beam-steering array 102. Although one array 102 is depicted, the autonomous vehicle 100 may include more than one array 102 as denoted by 1103 (e.g., see arrays 102 in FIG. 9). Exterior data 325 received by array 102 may include but is not limited to object location data 1148 (e.g., a coordinate of object 1134 in

the environment 1190), audio signal data 1162, trigger signal data 1171 and optionally, modulation signal data 1169.

[0121] Acoustic beam-steering array 102 may include a processor 1105 (e.g., a digital signal processor (DSP), field programmable gate array (FPGA), central processing unit (CPU), microprocessor, micro-controller, GPU's and/or clusters thereof, or other embedded processing system) that receives the exterior data 325 and processes the exterior data 325 to generate the beam 104 of steered acoustic energy (e.g., at angle β relative to a trajectory T_{AV} of AV 100) into the environment 1190 (e.g., in response to receiving the data representing the trigger signal 1171). Acoustic beam-steering array 102 may include several speakers S, with each speaker S in the array 102 being coupled with an output of amplifier A. Each amplifier A may include a gain input and a signal input. Processor 1105 may calculate data representing a signal gain G for the gain input of each amplifier A and may calculate data representing a signal delay D for the signal input of each amplifier A. Processor 1105 may access and/or receive data representing information on speakers S (e.g., from an internal and/or external data source) and the information may include but is not limited to an array width (e.g., a distance between the first speaker and last speaker in array 102), speaker S spacing in the array (e.g., a distance between adjacent speakers S in array 102), a wave front distance between adjacent speakers S in the array, the number of speakers S in the array, speaker characteristics (e.g., frequency response, output level per watt of power, radiating area, etc.), just to name a few. Each speaker S and its associated amplifier A in array 102 may constitute a monaural channel and the array 102 may include n monaural channels, where the number of monaural channels n, depending on speaker size and an enclosure size of the array 102, may vary. For example n may be 30 or may be 320. For example, in an ultrasonic parametric array implementation of the array 102, n may be on the order of about 80 to about 300. In some examples, the spacing between speakers in the array 102 may not be linear for some or all of the speakers in the array 102.

[0122] In example 1100 of FIG. 11A, the steered beam of acoustic energy 104 is being steered at an object 1134 (e.g., a skateboarder) having a predicted location L_o in the environment 1190 that may conflict with the trajectory T_{av} of the autonomous vehicle 100. A location of the object 1134 may be included in the exterior data 325 as the object location data 1148. Object location data 1148 may be data representing a coordinate of the object 1134 (e.g., an angle, Cartesian coordinates, a polar coordinate, etc.). Array 102 may process the object location data 1148 to calculate an angle β to direct the beam 104 at the object 1134. The angle β may be measured relative to the trajectory T_{av} or relative to some point on a frame of the vehicle 100 (e.g., see 100r in FIG. 11C). If the predicted location L_o changes due to motion of the object

1134, then the other systems of the autonomous vehicle system 101 may continue to track and update data associated with the autonomous vehicle 100 and the object 1134 to compute updated object location data 1134. Accordingly, the angle β may change (e.g., is re-computed by processor 1105) as the location of the object 1134 and/or the vehicle 100 changes. In some examples, the angle β may be computed (e.g., by the planner system) to take into account not only the currently predicted direction (e.g., coordinate) to the object, but also a predicted direction to the object at a future time t , where a magnitude of a time delay in firing the array 102 may be a function of a data processing latency of a processing system of the vehicle 100 (e.g., processing latency in one or more of the planner system, the perception system or the localizer system). Accordingly, the planner system may cause the array 102 to emit the sound where the object is predicted to be a some fraction of a second from the time the array 102 is fired to account for the processing latency, and/or the speed of sound itself (e.g., based on environmental conditions), depending on how far away the object is from the vehicle 100, for example.

[0123] FIG. 11 B depicts one example of a flow diagram 1150 for implementing an acoustic beam-steering in an autonomous vehicle. At a stage 1152, data representing a trajectory of the autonomous vehicle 100 in the environment may be calculated based on data representing a location of the autonomous vehicle 100 (e.g., local pose data). At a stage 1154, data representing a location (e.g., a coordinate) of an object disposed in the environment may be determined (e.g., from object track data derived from sensor data). Data representing an object type may be associated with the data representing the location of the object. At a stage 1156, data representing a predicted location of the object in the environment may be predicted based on the data representing the object type and the data representing the location of the object in the environment. At a stage 1158, data representing a threshold location in the environment associated with an audio alert (e.g., from array 102) may be estimated based on the data representing the predicted location of the object and the data representing the trajectory of the autonomous vehicle. At a stage 1160, data representing an audio signal associated with the audio alert may be selected. At a stage 1162, the location of the object being coincident with the threshold location may be detected. As one example, the predicted location of the object crossing the threshold location may be one indication of coincidence. At a stage 1164, data representing a signal gain "G" associated with a speaker channel of the acoustic beam-steering array 102 may be calculated. An array 102 having n speaker channels may have n different gains "G" calculated for each speaker channel in the n speaker channels. The data representing the signal gain "G" may be applied to a gain input of an amplifier A coupled with a speaker S

in a channel (e.g., as depicted in array 102 of FIG. 11A). At a stage 1166, data representing a signal delay "D" may be calculated for each of the n speaker channels of the array 102. The data representing the signal delay "D" may be applied to a signal input of an amplifier A coupled with a speaker S in a channel (e.g., as depicted in array 102 of FIG. 11A). At a stage 1168, the vehicle controller (e.g., 350 of FIG. 11A) may implement the acoustic alert by causing the array 102 (e.g., triggering, activating, or commanding array 102) to emit a beam of steered acoustic energy (e.g., beam 104) in a direction of propagation (e.g., direction of propagation 106) determined by the location of the object (e.g., a coordinate of the object in the environment), the beam of steered acoustic energy being indicative of the audio signal.

[0124] The stages of flow diagram 1150 may be implemented for one or more of the arrays 102, and one or more stages of flow diagram 1150 may be repeated. For example, predicted object path, object location (e.g., object coordinates), predicted object location, threshold location, vehicle trajectory, audio signal selection, coincidence detection, and other stages may be repeated to update and/or process data as necessary while the autonomous vehicle 100 travels through the environment and/or as the object changes locations in the environment.

[0125] FIG. 11C depicts a top plan view of one example 1170 of an autonomous vehicle steering acoustic energy associated with an acoustic alert to an object. In FIG. 11 C, autonomous vehicle 100 may have a trajectory T_{av} along a roadway between lane markers denoted by dashed lines 1177. A detected object 1171 in the environment external to the autonomous vehicle 100 has been classified as an automotive object type having a predicted location L_c in the environment that is estimated to conflict with the trajectory T_{av} of the autonomous vehicle 100. Planner system may generate three threshold locations t-1, t-2, and t-3 (e.g., having arcuate profiles 1121, 1122 and 1123), respectively. The three threshold locations t-1, t-2, and t-3 may be representative of escalating threat levels ranked from a low threat level at threshold location t-1 (e.g., a relatively safe distance away from vehicle 100), a medium threat level at threshold location t-2 (e.g., a distance that is cautiously close to the vehicle 100) and a high threat level at threshold location t-3 (e.g., a distance that is dangerously close to vehicle 100), for example. A different audio signal for an audio alert to be generated at each of the three threshold locations t-1, t-2, and t-3 may be selected to audibly convey the escalating levels of threat as the predicted location L_c of the object 1170 brings the object 1171 closer to the location of the autonomous vehicle 100 (e.g., close enough for a potential collision with autonomous vehicle 100). The beam of steered acoustic energy 104 may be indicative of the information included in the selected audio signal (e.g., audio signals 104a, 104b and 104c).

[0126] When object type 1171 crosses or otherwise has its location coincident with threshold location $t-1$, the planner system may generate a trigger signal to activate the acoustic array 102 positioned to generate an acoustic alert using an audio signal 104a (e.g., to convey a non-threatening acoustic alert) along a direction of propagation 10Ga based on a coordinate of the object 1171. For example, the coordinate may be an angle β_a measured between the trajectory T_{av} and the direction of propagation 10Ga. A reference point for the coordinate (e.g., angles β_a , β_b and β_c) may be a point 102r on the array 102 or some other location on the autonomous vehicle 102, such as a point 100r, for example. As the object 1171 continues along its predicted location L_c and crosses threshold location $t-2$, another acoustic alert may be triggered by the planner system, using coordinate β_b , an audio signal 104b (e.g., to convey an urgent acoustic alert) and a direction of propagation 106b. Further travel by object 1171 that crosses threshold location $t-3$ may trigger yet another acoustic alert by planner system using a coordinate β_c , an audio signal 104c (e.g., to convey an extremely urgent acoustic alert) and direction of propagation 106c. In this example, a different audio signal (e.g., a digital audio file, whether prerecorded or dynamically generated, having different acoustic patterns, different magnitudes of acoustic power and/or volume, etc.) may be selected for audio signals 104a, 104b and 104c to convey the increasing levels of escalation to the object 1171 (e.g., to acoustically alert a driver of the vehicle).

[0127] For each of the acoustic alerts triggered by the planner system, the predicted location L_c of the object 1171 may change (e.g., relative to the location of the vehicle 100) and the planner system may receive updated object data (e.g., object tracking data from the perception system) to calculate (e.g., in real-time) changes in the location of the object 1171 (e.g., to calculate or recalculate β_a , β_b and β_c). The audio signal selected by planner system for each threshold location $t-1$, $t-2$ and $t-3$ may be different and may be configured to include audible information intended to convey ever increasing degrees of urgency for threshold locations $t-1$ to $t-2$ and $t-2$ to $t-3$, for example. The audio signal(s) selected by the planner system may be configured, based on the object type data for object 1171, to acoustically penetrate structures (1173, 1179) of the automobile, such as auto glass, door panels, etc., in order to garner the attention of a driver of the automobile. In some examples, if the object (e.g., the driver of the automobile) is detected (e.g., by the planner system) as changing its behavior (e.g., changing its predicted location, its predicted object path, or otherwise is no longer a threat to the vehicle 100 and/or its passengers), then the planner system may cause the array 102 to de-escalate the acoustic alert by lowering the level of urgency of the alert (e.g., by selecting an audio signal indicative of the lowered level of urgency). As one example, the selected audio signal may be

configured to generate frequencies in a range from about 220Hz to about 450Hz to acoustically penetrate structures (1173, 1179) on the object 1171. As another example, the array 102 may be configured to generate sound at frequencies in a range from about 220Hz to about 4.5kHz, or any other frequency range. Further, the sound generated by the array 102 may be changed (e.g., in volume, frequency, etc.) based on velocity changes in the autonomous vehicle 100. Sound frequencies emitted by the array 102 are not limited to the foregoing examples, and the array 102 may be configured to generate sound at frequencies that are within the range of human hearing, above the range of human hearing (e.g., ultrasonic frequencies), below the range of human hearing (e.g., infrasonic frequencies), or some combination thereof.

[0128] Autonomous vehicle 100 is depicted as having two arrays 102 disposed on an upper surface 100u (e.g., a roof of the vehicle 100); however, the vehicle 100 may have more or fewer arrays 102 than depicted and the placement of the arrays 102 may be different than depicted in FIG. 11C. Acoustic beam-steering array 102 may include several speakers and their associated amplifiers and driving electronics (e.g., a processor, a DSP, etc.). For purposes of explanation, each amplifier/speaker pair will be denoted as a channel, such that array 102 will include n-channels denoted as C1 for channel one all the way to Cn for the nth channel. In an enlarged view of the acoustic beam-steering array 102, each speaker S may be spaced apart from an adjacent speaker by a distance d. Distance d (e.g., a spacing between adjacent speakers (S)) may be the same for all speakers S in the array 102, such that all of the speakers S are spaced apart from one another by the distance d. In some examples, distance d may vary among the speakers S in the array 102 (e.g., distance d need not be identical between adjacent speakers in array 102). Distance d may be measured from a reference point on each speaker S, such as a center point of each speaker S.

[0129] A width W of the array 102 may be measured as a distance between the first speaker in the array 102 (e.g., channel C1) to the last speaker in the array 102 (e.g., channel Cn) and the width W may be measured from the center of the speaker in C1 to the center of the speaker in Cn, for example. In the direction of propagation 106 of the acoustic waves 104 generated by array 102, wave-fronts launched by adjacent speakers S in the array 102 may be delayed in time by a wave-front propagation time t_d . The wave-front propagation time t_d may be calculated as a distance between adjacent wave-fronts multiplied by the speed of sound c (e.g., $t_d = r * c$). In examples where the distance d between speakers S is the same for all speakers S in the array 102, the delay D calculated for each speaker S may be an increasing integer multiple of t_d . Therefore, for channel C1: ($t_{d1} = (r * c) * 1$), for channel C2: ($t_{d2} = (r * c) * 2$), and for channel Cn: ($t_{dn} = (r * c) * n$), for example. In some examples, the speed of sound c may be

calculated using data from an environmental sensor (e.g., sensor 877 of FIG. 8) to more accurately determine a value for the speed of sound c based on environmental conditions, such as altitude, air pressure, air temperature, humidity, and barometric pressure, for example.

[0130] FIG. 12A depicts one example 1200 of light emitters positioned external to an autonomous vehicle. In FIG. 12A, control data 317 from planner system 310 may be communicated to vehicle controller 350 which may in turn communicate exterior data 325 being configured to implement a visual alert using a light emitter 1202. Although one light emitter 1202 is depicted, the autonomous vehicle 100 may include more than one light emitter 1202 as denoted by 1203. Exterior data 325 received by light emitter 1202 may include but is not limited to data representing a light pattern 1212, data representing a trigger signal 1214 being configured to activate one or more light emitters 1202, data representing an array select 1216 being configured to select which light emitters 1202 of the vehicle 100 to activate (e.g., based on an orientation of the vehicle 100 relative to the object the visual alert is targeted at), and optionally, data representing drive signaling 1218 being configured to deactivate light emitter operation when the vehicle 100 is using its signaling lights (e.g., turn signal, brake signal, etc.), for example. In other examples, one or more light emitters 1202 may serve as a signal light, a head light, or both. An orientation of the autonomous vehicle 100 relative to an object may be determined based on a location of the autonomous vehicle 100 (e.g., from the localizer system) and a location of the object (e.g., from the perception system), a trajectory of the autonomous vehicle 100 (e.g., from the planner system) and a location of the object, or both, for example.

[0131] The light emitter 1202 may include a processor 1205 being configured to implement visual alerts based on the exterior data 325. A select function of the processor 1205 may receive the data representing the array select 1216 and enable activation of a selected light emitter 1202. Selected light emitters 1202 may be configured to not emit light L until the data representing the trigger signal 1214 is received by the selected light emitter 1202. The data representing the light pattern 1212 may be decoder by a decode function, and sub-functions may operate on the decoded light pattern data to implement a color function being configured to determine a color of light to be emitted by light emitter 1202, an intensity function being configured to determine an intensity of light to be emitted by light emitter 1202, and a duration function being configured to determine a duration of light emission from the light emitter 1202, for example. A data store (Data) may include data representing configurations of each light emitter 1202 (e.g., number of light emitting elements E , electrical characteristics of light emitting elements E , positions of light emitters 1202 on vehicle 100, etc.). Outputs from the

various functions (e.g., decoder, select, color, intensity and duration) may be coupled with a driver 1207 configured to apply signals to light emitting elements E1 - En of the light emitter 1202. Each light emitting element E may be individually addressable based on the data representing the light pattern 1212. Each light emitter 1202 may include several light emitting elements E, such that n may represent the number of light emitting elements E in the light emitter 1202. As one example, n may be greater than 50. The light emitters 1202 may vary in size, shape, number of light emitting elements E, types of light emitting elements E, and locations of light emitters 1202 positioned external to the vehicle 100 (e.g., light emitters 1202 coupled with a structure of the vehicle 100 operative to allow the light emitter to emit light L into the environment, such as roof 100u or other structure of the vehicle 100).

[0132] As one example, light emitting elements E1 - En may be solid-state light emitting devices, such as light emitting diodes or organic light emitting diodes, for example. The light emitting elements E1 - En may emit a single wavelength of light or multiple wavelengths of light. The light emitting elements E1 - En may be configured to emit multiple colors of light, based on the data representing the light pattern 1212, such as red, green, blue and one or more combinations of those colors, for example. The light emitting elements E1 - En may be a RGB light emitting diode (RGB LED) as depicted in FIG. 12A. The driver 1207 may be configured to sink or source current to one or more inputs of the light emitting elements E1 - En, such as one or more of the red -R, green-G or blue-B inputs of the light emitting elements E1 - En to emit light L having a color, intensity, and duty cycle based on the data representing the light pattern 1212. Light emitting elements E1 - En are not limited to the example 1200 of FIG. 12A, and other types of light emitter elements may be used to implement light emitter 1202.

[0133] [0086] Further to FIG. 12A, an object 1234 having a predicted location Lo that is determined to be in conflict with a trajectory Tav of the autonomous vehicle 100 is target for a visual alert (e.g., based on one or more threshold locations in environment 1290). One or more of the light emitters 1202 may be triggered to cause the light emitter(s) to emit light L as a visual alert. If the planner system 310 determines that the object 1234 is not responding (e.g., object 1234 has not altered its location to avoid a collision), the planner system 310 may select another light pattern configured to escalate the urgency of the visual alert (e.g., based on different threshold locations having different associated light patterns). On the other hand, if the object 1234 is detected (e.g., by the planner system) as responding to the visual alert (e.g., object 1234 has altered its location to avoid a collision), then a light pattern configured to deescalate the urgency of the visual alert may be selected. For example, one or more of light

color, light intensity, light pattern or some combination of the foregoing, may be altered to indicate the de-escalation of the visual alert.

[0134] Planner system 310 may select light emitters 1202 based on an orientation of the autonomous vehicle 100 relative to a location of the object 1234. For example, if the object 1234 is approaching the autonomous vehicle 100 head-on, then one or more light emitters 1202 positioned external to the vehicle 100 that are approximately facing the direction of the object's approach may be activated to emit light L for the visual alert. As the relative orientation between the vehicle 100 and the object 1234 changes, the planner system 310 may activate other emitters 1202 positioned at other exterior locations on the vehicle 100 to emit light L for the visual alert. Light emitters 1202 that may not be visible to the object 1234 may not be activated to prevent potential distraction or confusion in other drivers, pedestrians or the like, at whom the visual alert is not being directed.

[0135] FIG. 12B depicts profile views of examples of light emitter 1202 positioning on an exterior of an autonomous vehicle 100. In example 1230, a partial profile view of a first end of the vehicle 100 (e.g., a view along direction of arrow 1236) depicts several light emitters 1202 disposed at different positions external to the vehicle 100. The first end of the vehicle 100 may include lights 1232 that may be configured for automotive signaling functions, such as brake lights, turn signals, hazard lights, head lights, running lights, etc. In some examples, light emitters 1202 may be configured to emit light L that is distinct (e.g., in color of light, pattern of light, intensity of light, etc.) from light emitted by lights 1232 so that the function of light emitters 1202 (e.g., visual alerts) is not confused with the automotive signaling functions implemented by lights 1232. In some examples, lights 1232 may be configured to implement automotive signaling functions and visual alert functions. Light emitters 1202 may be positioned in a variety of locations including but not limited to pillar sections, roof 100u, doors, bumpers, and fenders, for example. In some examples, one or more of the light emitters 1202 may be positioned behind an optically transparent or partially transparent surface or structure of the vehicle 100, such as behind a window, a lens, or a covering, etc., for example. Light L emitted by the light emitter 1202 may pass through the optically transparent surface or structure and into the environment.

[0136] In example 1235, a second end of the vehicle 100 (e.g., view along direction opposite of arrow 1236) may include lights 1231 that may be configured for traditional automotive signaling functions and/or visual alert functions. Light emitters 1202 depicted in example 1235 may also be positioned in a variety of locations including but not limited to pillar sections, roof 100u, doors, bumpers, and fenders, for example.

[0137] Note that according to some examples, lights 1231 and 1232 may be optional, and the functionality of automotive signaling functions, such as brake lights, turn signals, hazard lights, head lights, running lights, etc., may be performed by anyone of the one or more light emitters 1202.

[0138] FIG. 12C depicts a top plan view of one example 1240 of light emitter 1202 activation based on an orientation of an autonomous vehicle relative to an object. In FIG. 12C, object 1234 has a predicted location L_0 relative to a location of the autonomous vehicle 100. A relative orientation of the autonomous vehicle 100 with the object 1234 may provide complete sensor coverage of the object 1234 using sensor suites 820 positioned to sense quadrants 2 and 3 and partial sensor coverage in quadrant 1. Based on the relative orientations of the vehicle 100 and the object 1234, a sub-set of the light emitters denoted as 1202a (e.g., on a side and an end of the vehicle 100) may be visually perceptible by the object 1234 and may be activated to emit light L into environment 1290.

[0139] FIG. 12D depicts a profile view of one example 1245 of light emitter activation based on an orientation of an autonomous vehicle relative to an object. In FIG. 12D, object 1234 has a predicted location L_0 relative to a location of the autonomous vehicle 100. Based on the relative orientations of the vehicle 100 and the object 1234, a sub-set of the light emitters denoted as 1202a (e.g., on a side of the vehicle 100) may be visually perceptible by the object 1234 and may be activated to emit light L into environment 1290. In the example of FIG. 12D, the relative orientation of the vehicle 100 with the object 1234 is different than depicted in FIG. 12C as the approach of the object 1234 is not within the sensor coverage of quadrant 1. Accordingly, light emitters 1202 positioned at an end of the vehicle 100 may not be visually perceptible to the object 1234 and may not be activated for a visual alert.

[0140] FIG. 12E depicts one example of a flow diagram 1250 for implementing a visual alert from a light emitter in an autonomous vehicle. At a stage 1252, data representing a trajectory of an autonomous vehicle in an environment external to the autonomous vehicle may be calculated based on data representing a location of the autonomous vehicle in the environment. At a stage 1254, data representing a location of an object in the environment may be determined. The object may include an object type. At a stage 1256, a predicted location of the object in the environment may be predicted based on the object type and the object location. At a stage 1258, data representing a threshold location in the environment associated with a visual alert may be estimated based on the trajectory of the autonomous vehicle and the predicted location of the object. At a stage 1260, data representing a light pattern associated with the threshold location may be selected. At a stage 1262, the location of the object being

coincident with the threshold location may be detected. At a stage 1264, data representing an orientation of the autonomous vehicle relative to the location of the object may be determined. At a stage 1266, one or more light emitters of the autonomous vehicle may be selected based on the orientation of the autonomous vehicle relative to the location of the object. At a stage 1268, selected light emitters may be caused (e.g., activated, triggered) to emit light indicative of the light pattern into the environment to implement the visual alert.

[0141] FIG. 12F depicts a top plan view of one example 1270 of a light emitter 1202 of an autonomous vehicle 100 emitting light L to implement a visual alert in concert with optional acoustic alerts from one or more arrays 102. In FIG. 12F, autonomous vehicle 100 has a trajectory T_{av} along a roadway between lane markers denoted by dashed lines 1277, a detected object 1272 has a predicted location L_o that is approximately parallel to and in an opposite direction to the trajectory T_{av} . A planner system of autonomous vehicle 100 may estimate three threshold locations T -1, T -2 and T -3 to implement a visual alert. Light emitters 1202 positioned at an end of the vehicle 100 in a direction of travel 1279 (e.g., light emitters 1202 are facing the object 1272) are selected for the visual alert. In contrast, arrays 1202 positioned at the other end of the vehicle 100 that are not facing the direction of travel 1279, may not be selected for the visual alert because they may not be visually perceptible by the object 1272 and they may confuse other drivers or pedestrians, for example. Light patterns 1204a, 1204b and 1204c may be associated with threshold locations T-1, T-2 and T-3, respectively, and may be configured to implement escalating visual alerts (e.g., convey increasing urgency) as the predicted location L_o of the object 1272 gets closer to the location of the vehicle 100.

[0142] Further to FIG. 12F, another detected object 1271 may be selected by the planner system of the vehicle 100 for an acoustic alert as described above in reference to FIGS. 11A - 11C. Estimated threshold locations t-1 - t-3 for object 1271 may be different than those for object 1272 (e.g., T-1, T-2 and T-3). For example, acoustic alerts may be audibly perceptible at a greater distance from the vehicle 100 than visual perception of visual alerts. A velocity or speed of object 1271 may be greater than a velocity or speed of object 1272 (e.g., an automobile vs. a bicycle) such that the threshold locations t-1 - t-3 are placed further out due to a higher velocity of the object 1271 in order to provide sufficient time for the object 1271 to alter its location to avoid a collision and/or for the vehicle 100 to take evasive maneuvers and/or activate one or more of its safety systems. Although FIG. 12F depicts an example of a visual alert associated with object 1272 and an acoustic alert associated with object 1271, the number and type of safety system activated (e.g., interior, exterior or drive system) to address behavior of objects in the environment are not limited to the example depicted and one or more safety

systems may be activated. As one example, an acoustic alert, a visual alert, or both, may be communicated to object 1271, object 1272, or both. As another example, one or more bladders may be deployed and one or more seat belts may be tensioned as object 1271, object 1272, or both are close to colliding with or coming within an unsafe distance of the vehicle 100 (e.g., a predicted impact time is about 2 seconds or less away).

[0143] The planner system may predict one or more regions of probable locations (e.g., 565 in FIGS. 5 and 6) of the objects in the environment based on predicted motion of each object and/or predicted location of each object. The regions of probable locations and the size, number, spacing, and shapes of threshold locations within the regions of probable locations may vary based on many factors including but not limited to object characteristics (e.g., speed, type, location, etc.), the type of safety system selected, the velocity of the vehicle 100, and the trajectory of the vehicle 100, for example.

[0144] FIG. 13A depicts one example 1300 of a bladder system in an exterior safety system of an autonomous vehicle. Exterior data 325 received by the bladder system 369 may include data representing bladder selection 1312, data representing bladder deployment 1314, and data representing bladder retraction 1316 (e.g., from a deployed state to an un-deployed state). A processor 1305 may process exterior data 325 to control a bladder selector coupled with one or more bladder engines 1311. Each bladder engine 1311 may be coupled with a bladder 1310 as denoted by Bladder-1 through Bladder-n. Each bladder 1310 may be activated, by its respective bladder engine 1311, from an un-deployed state to a deployed state. Each bladder 1310 may be activated, by its respective bladder engine 1311, from the deployed state to the un-deployed state. In the deployed state, a bladder 1310 may extend outward of the autonomous vehicle 100 (e.g., outward of a body panel or other structure of the vehicle 100). Bladder engine 1311 may be configured to cause a change in volume of its respective bladder 1310 by forcing a fluid (e.g., a pressurized gas) under pressure into the bladder 1310 to cause the bladder 1310 to expand from the un-deployed position to the deployed position. A bladder selector 1317 may be configured to select which bladder 1310 (e.g., in Bladder-1 through Bladder-n) to activate (e.g., to deploy) and which bladder 1310 to de-activate (e.g., return to the un-deployed state). A selected bladder 1310 may be deployed upon the processor receiving the data representing bladder deployment 1314 for the selected bladder 1310. A selected bladder 1310 may be returned to the un-deployed state upon the processor receiving the data representing bladder retractions 1316 for the selected bladder 1310. The processor 1305 may be configured to communicate data to bladder selector 1317 to cause the bladder selector 1317 to deploy a

selected bladder 1310 (e.g., via its bladder engine 1311) or to return a deployed bladder 1310 to the un-deployed state (e.g., via its bladder engine 1311).

[0145] A bladder 1310 may be made from a flexible material, a resilient material, an expandable material, such as rubber or a synthetic material, or any other suitable material, for example. In some examples, a material for the bladder 1310 may be selected based on the material being reusable (e.g., if a predicted impact to the bladder 1310 does not occur or the collision occurs but does not damage the bladder 1310). As one example, the bladder 1310 may be made from a material used for air springs implemented in semi-tractor-trailer trucks. Bladder engine 1311 may generate a pressurized fluid that may be introduced into the bladder 1310 to expand the bladder 1310 to the deployed position or couple the bladder 1310 with a source of pressurized fluid, such as a tank of pressurized gas or a gas generator. Bladder engine 1311 may be configured to release (e.g., via a valve) the pressurized fluid from the bladder 1310 to contract the bladder 1310 from the deployed position back to the un-deployed position (e.g., to deflate the bladder 1310 to the un-deployed position). As one example, bladder engine 1311 may vent the pressurized fluid in its respective bladder 1310 to atmosphere. In the deployed position, the bladder 1310 may be configured to absorb forces imparted by an impact of an object with the autonomous vehicle 100, thereby, reducing or preventing damage to the autonomous vehicle and/or its passengers. For example, the bladder 1310 may be configured to absorb impact forces imparted by a pedestrian or a bicyclist that collides with the autonomous vehicle 100.

[0146] Bladder data 1319 may be accessed by one or more of processor 1305, bladder selector 1317 or bladder engines 1311 to determine bladder characteristics, such as bladder size, bladder deployment time, bladder retraction time (e.g., a time to retract the bladder 1310 from the deployed position back to the un-deployed position); the number of bladders, the locations of bladders disposed external to the vehicle 100, for example. Bladders 1310 may vary in size and location on the autonomous vehicle 100 and therefore may have different deployment times (e.g., an inflation time) and may have different retraction times (e.g., a deflation time). Deployment times may be used in determining if there is sufficient time to deploy a bladder 1310 or multiple bladders 1310 based on a predicted time of impact of an object being tracked by the planner system 310, for example. Bladder engine 1311 may include sensors, such as a pressure sensor to determine pressures in a bladder 1310 when deployed and when un-deployed, and to determine if an impact has ruptured or otherwise damaged a bladder 1310 (e.g., a rupture causing a leak in the bladder 1310). The bladder engine 1311 and/or sensor system 320 may include a motion sensor (e.g., an accelerometer, MOT 888 in FIG. 8) to detect

motion from an impact to the autonomous vehicle 100. A bladder 1310 and/or its respective bladder engine 1311 that is not damaged by an impact may be reused. In the event the predicted impact does not occur (e.g., there is no collision between the vehicle 100 and an object) the bladder 1310 may be returned to the un-deployed state (e.g., via bladder engine 1311) and the bladder 1310 may be subsequently reused at a future time.

[0147] Further to FIG. 13A, an object 1334 having predicted location L_o may be approaching the autonomous vehicle 100 from one of its sides such that a trajectory T_{av} of the autonomous vehicle 100 is approximately perpendicular to a predicted object path of the object 1334. Object 1334 may be predicted to impact the side of the autonomous vehicle 100, and exterior data 325 may include data configured to cause bladder selector 1311 to select one or more bladders 1310 positioned on the side of the autonomous vehicle 100 (e.g., the side on which the impact is predicted to occur) to deploy in advance of the predicted impact.

[0148] FIG. 13B depicts examples 1330 and 1335 of bladders in an exterior safety system of an autonomous vehicle. In example 1330, vehicle 100 may include several bladders 1310 having positions associated with external surfaces and/or structures of the vehicle 100. The bladders 1310 may have different sizes and shapes. Bladders 1310 may be concealed behind other structures of the vehicle or may be disguised with ornamentation or the like. For example, a door panel or fender of the vehicle 100 may include a membrane structure and the bladder 1310 may be positioned behind the membrane structure. Forces generated by deployment of the bladder 1310 may rupture the membrane structure and allow the bladder to expand outward in a direction external to the vehicle 100 (e.g., deploy outward into the environment). Similarly, in example 1335, vehicle 100 may include several bladders 1310. The bladders depicted in examples 1330 and 1335 may be symmetrical in location and/or size on the vehicle 100.

[0149] FIG. 13C depicts examples 1340 and 1345 of bladder deployment in an autonomous vehicle. In example 1340, an object 1371 (e.g., a car) is on a predicted collision course with vehicle 100 and has a predicted location of L_o . Autonomous vehicle 100 has a trajectory T_{av} . Based on a relative orientation of the vehicle 100 with the object 1371, a predicted impact location on the vehicle 100 is estimated to be in quadrants 2 and 3 (e.g., impact to a side of the vehicle 100). Two passengers P located in the interior 100i of the vehicle 100 may be at risk due to a crumple zone distance z_1 measured from the side of vehicle 100 to the passenger P seating position in the interior 100i. Planner system 310 may compute an estimated time to impact T_{impact} for the object 1371 (e.g., using kinematics calculator 384) to determine whether there is sufficient time to maneuver the autonomous vehicle 100 to avoid the collision or to reduce potential injury to passengers P . If the planner system 310 determines that the

time to maneuver the vehicle 100 is less than the time of impact (e.g., $T_{\text{manuever}} < T_{\text{impact}}$), the planner system may command the drive system 326 to execute an avoidance maneuver 1341 to rotate the vehicle 100 in a clockwise direction of the arrow (e.g., arrow for avoidance maneuver 1341) to position the end of the vehicle 100 in the path of the object 1371. Planner system may also command activation of other interior and exterior safety systems to coincide with the avoidance maneuver 1341, such as seat belt tensioning system, bladder system, acoustic beam-steering arrays 102 and light emitters 1202, for example.

[0150] In example 1345, the vehicle 100 has completed the avoidance maneuver 1341 and the object 1371 is approaching from an end of the vehicle 100 instead of the side of the vehicle 100. Based on the new relative orientation between the vehicle 100 and the object 1371, the planner system 310 may command selection and deployment of a bladder 1310' positioned on a bumper at the end of the vehicle 100. If an actual impact occurs, the crumple zone distance has increased from z_1 to z_2 (e.g., $z_2 > z_1$) to provide a larger crumple zone in the interior 100i of the vehicle 100 for passengers P. Prior to the avoidance maneuver 1341, seat belts worn by passengers P may be pre-tensioned by the seat belt tensioning system to secure the passengers P during the maneuver 1341 and in preparation for the potential impact of the object 1371.

[0151] In example 1345, a deployment time of the bladder 1310', T_{deploy} , is determined to be less (e.g., by planner system 310) than the predicted impact time, T_{impact} , of the object 1371. Therefore, there is sufficient time to deploy bladder 1310' prior to a potential impact of the object 1371. A comparison of activation times and impact times may be performed for other safety systems such as the seat belt tensioning system, seat actuator system, acoustic arrays and light emitters, for example.

[0152] The drive system (e.g., 326 in FIG. 3B) may be commanded (e.g., via planner system 310) to rotate the wheels of the vehicle (e.g., via the steering system) and orient the vehicle 100 (e.g., via the propulsion system) to the configuration depicted in example 1345. The drive system may be commanded (e.g., via planner system 310) to apply brakes (e.g., via the braking system) to prevent the vehicle 100 from colliding with other objects in the environment (e.g., prevent the vehicle 100 from being pushed into other objects as a result of forces from the impact).

[0153] FIG. 14 depicts one example 1400 of a seat belt tensioning system in an interior safety system 322 of an autonomous vehicle 100. In FIG. 14, interior data 323 may be received by seat belt tensioning system 361. Interior data 323 may include but is not limited to data representing a belt tensioner select signal 1412, a seat belt tension trigger signal 1414, and a

seat belt tension release signal 1416. The belt tensioner select signal 1412 may select one or more belt tensioners 1411, with each belt tensioner 1411 including a seat belt 1413 (also denoted as B-1, B-2 to B-n). Each belt 1413 may be mechanically coupled with a tensioning mechanism (not shown) in the belt tensioner 1411. The tensioning mechanism may include a reel configured to reel in a portion of the belt on the reel the belt 1413 is wrapped around to take the slack out of the belt 1413. A belt tensioner 1411 selected by the belt tensioner select signal 1412 may upon receiving the seat belt tension trigger signal 1414, apply tension to its respective belt 1413. For example, belt tensioner 1411 having belt 1413 (B-2) may actuate belt B-2 from a slack state (e.g., not tightly coupled to a passenger wearing belt B-2) to a tension state (denoted by dashed line). In the tension state, belt B-2 may apply pressure to a passenger that may tightly couple the passenger to the seat during an avoidance maneuver and/or in anticipation of a predicted collision with an object, for example.

[0154] The belt B-2 may be returned from the tension state to and back to the slack state by releasing the seat belt tension trigger signal 1414 or by releasing the seat belt tension trigger signal 1414 followed by receiving the seat belt tension release signal 1416. A sensor (e.g., a pressure or force sensor) (not shown) may detect whether a seat in the autonomous vehicle is occupied by a passenger and may allow activation of the belt tensioner select signal 1412 and/or the seat belt tension trigger signal 1414 if the sensor indicates the seat is occupied. If the seat sensor does not detect occupancy of a seat, then the belt tensioner select signal 1412 and/or the seat belt tension trigger signal 1414 may be de-activated. Belt data 1419 may include data representing belt characteristics including but not limited to belt tensioning time, belt release times, and maintenance logs for the seat belts 1413 in seat belt system 361, for example. Seat belt system 361 may operate as a distinct system in autonomous vehicle 100 or may operate in concert with other safety systems of the vehicle 100, such as the light emitter(s), acoustic array(s), bladder system, seat actuators, and the drive system, for example.

[0155] FIG. 15 depicts one example 1500 of a seat actuator system 363 in an interior safety system 322 of an autonomous vehicle 100. In one example, the seat actuator system 363 may be configured to actuate a seat 1518 (e.g., a Seat-1 through a Seat-n) from a first position in the interior of the autonomous vehicle 100 to a second position in the interior of the autonomous vehicle 100 using energy from an impact force 1517 imparted to the vehicle 100 from an object (not shown) in the environment 1590 due to a collision between the vehicle 100 and the object (e.g., another vehicle). A force 1513 mechanically communicated to the seat (e.g., Seat-n) from the impact force 1517, may move the seat from the first position (e.g., near an end of the vehicle 100) to a second position (e.g., towards the center of the interior 100i of the vehicle 100), for

example. A counter acting force c-force 1515 may be applied to the seat (e.g., Seat-n) to control acceleration forces caused by the force 1513 (note, that while not shown, the directions of c-force 1515 and force 1513 as depicted in FIG. 15 may be in substantially common direction of impact force 1517). The counter acting force c-force 1515 may be a spring being configured to compress to counteract force 1513 or being configured to stretch to counteract force 1513. In other examples, counter acting force c-force 1515 may be generated by a damper (e.g., a shock absorber) or by an air spring, for example. A mechanism that provides the counter acting force c-force 1515 may be coupled to a seat coupler 1511 and to the seat (e.g., Seat-n). The seat coupler 1511 may be configured to anchor the mechanism that provides the counter acting force c-force 1515 to a chassis or other structure of the vehicle 100. As the impact force 1517 causes mechanical deformation of the structure of the vehicle 100 (e.g., collapses a crumple zone), a ram or other mechanical structure coupled to the seat may be urged forward (e.g., from the first position to the second position) by the deforming structure of the vehicle to impart the force 1513 to the seat, while the counter acting force c-force 1515 resists the movement of the seat from the first position to the second position.

[0156] In other examples, seat coupler 1511 may include an actuator to electrically, mechanically, or electromechanically actuate a seat 1518 (e.g., the Seat-n) from the first position to the second position in response to data representing a trigger signal 1516. Seat coupler 1511 may include a mechanism (e.g., a spring, a damper, an air spring, a deformable structure, etc.) that provides the counter acting force c-force 1515. Data representing a seat select 1512 and data representing an arming signal 1514 may be received by a processor 1505. A seat selector 1519 may select one or more of the seat couplers 1511 based on the data representing the seat select 1512. Seat selector 1519 may not actuate a selected seat until the data representing the arming signal 1514 is received. The data representing the arming signal 1514 may be indicative of a predicted collision with the vehicle 100 having a high probability of occurring (e.g., an object based on its motion and location is predicted to imminently collide with the vehicle}. The data representing the arming signal 1514 may be used as a signal to activate the seat belt tensioning system. Seats 1518 (e.g., seat-1 through seat-n) may be seats that seat a single passenger (e.g., a bucket seat) or that seat multiple passengers (e.g., a bench seat), for example. The seat actuator system 363 may act in concert with other interior and exterior safety systems of the vehicle 100.

[0157] FIG. 16A depicts one example 1600 of a drive system 326 in an autonomous vehicle 100. In FIG. 16A, drive data 327 communicated to drive system 326 may include but is not limited to data representing steering control 1612, braking control 1614, propulsion control

1618 and signal control 1620. Drive data 327 may be used for normal driving operations of the autonomous vehicle 100 (e.g., picking up passengers, transporting passengers, etc.), but also may be used to mitigate or avoid collisions and other potentially dangerous events related to objects in an environment 1690.

[0158] Processor 1605 may communicate drive data 327 to specific drive systems, such as steering control data to the steering system 361, braking control data to the braking system 364, propulsion control data to the propulsion system 368 and signaling control data to the signaling system 362. The steering system 361 may be configured to process steering data to actuate wheel actuators WA-1 through WA-n. Vehicle 100 may be configured for multi-wheel independent steering (e.g., four wheel steering). Each wheel actuator WA-1 through WA-n may be configured to control a steering angle of a wheel coupled with the wheel actuator. Braking system 364 may be configured to process braking data to actuate brake actuators BA-1 through BA-n. Braking system 364 may be configured to implement differential braking and anti-lock braking, for example. Propulsion system 368 may be configured to process propulsion data to actuate drive motors DM-1 through DM-n (e.g., electric motors). Signaling system 362 may process signaling data to activate signal elements S-1 through S-n (e.g., brake lights, turn signals, headlights, running lights, etc.). In some examples, signaling system 362 may be configured to use one or more light emitters 1202 to implement a signaling function. For example, signaling system 362 may be configured to access all or a portion of one or more light emitters 1202 to implement a signaling function (e.g., brake lights, turn signals, headlights, running lights, etc.).

[0159] FIG. 16B depicts one example 1640 of obstacle avoidance maneuvering in an autonomous vehicle 100. In FIG. 16B, an object 1641 (e.g., an automobile) has a predicted location L_o that is in conflict with trajectory T_{av} of autonomous vehicle 100. The planner system may calculate that there is not sufficient time to use the drive system to accelerate the vehicle 100 forward to a region 1642 located along trajectory T_{av} because the object 1641 may collide with the vehicle 100; therefore, region 1642 may not be safely maneuvered into and the region 1642 may be designated (e.g., by the planner system) as a blocked region 1643. However, the planner system may detect (e.g., via sensor data received by the perception system and map data from the localizer system) an available open region in the environment around the vehicle 100. For example, a region 1644 may be safely maneuvered into (e.g., region 1644 has no objects, moving or static, to interfere with the trajectory of the vehicle 100). The region 1644 may be designated (e.g., by the planner system) as an open region 1645. The planner system may command the drive system (e.g., via steering, propulsion, and braking

data) to alter the trajectory of the vehicle 100 from its original trajectory T_{av} to an avoidance maneuver trajectory T_m , to autonomously navigate the autonomous vehicle 100 into the open region 1645.

[0160] In concert with obstacle avoidance maneuvering, the planner system may activate one or more other interior and/or exterior safety systems of the vehicle 100, such causing the bladder system to deploy bladders on those portions of the vehicle that may be impacted by object 1641 if the object 1641 changes velocity or in the event the obstacle avoidance maneuver is not successful.

[0161] The seat belt tensioning system may be activated to tension seat belts in preparation for the avoidance maneuver and to prepare for a potential collision with the object 1641. Although not depicted in FIG. 16B, other safety systems may be activated, such as one or more acoustic arrays 102 and one or more light emitters 1202 to communicate acoustic alerts and visual alerts to object 1641. Belt data and bladder data may be used to compute tensioning time for seat belts and bladder deployment time for bladders and those computed times may be compared to an estimated impact time to determine if there is sufficient time before an impact to tension belts and/or deploy bladders (e.g., $T_{deploy} < T_{impact}$ and/or $T_{tension} < T_{impact}$). Similarly, the time necessary for drive system to implement the maneuver into the open region 1645 may be compared to the estimated impact time to determine if there is sufficient time to execute the avoidance maneuver (e.g., $T_{maneuver} < T_{impact}$).

[0162] FIG. 16C depicts another example 1660 of obstacle avoidance maneuvering in an autonomous vehicle 100. In FIG. 16C, an object 1661 has a predicted location L_o that may result in a collision (e.g., a rear-ending) of autonomous vehicle 100. Planner system may determine a predicted impact zone (e.g., a region or probabilities where a collision might occur based on object dynamics). Prior to a predicted collision occurring, planner system may analyze the environment around the vehicle 100 (e.g., using the overlapping sensor fields of the sensor in the sensor system) to determine if there is an open region the vehicle 100 may be maneuvered into. The predicted impact zone is behind the vehicle 100 and is effectively blocked by the predicted location L_o having a velocity towards the location of the vehicle 100 (e.g., the vehicle cannot safely reverse direction to avoid the potential collision). The predicted impact zone may be designated (e.g., by the planner system) as a blocked region 1681. Traffic lanes to the left of the vehicle 100 lack an available open region and are blocked due to the presence of three objects 1663, 1665 and 1673 (e.g., two cars located in the adjacent traffic lane and one pedestrian on a sidewalk). Accordingly, the region may be designated as blocked region 1687. A region ahead of the vehicle 100 (e.g., in the direction of trajectory T_{av}) is blocked due to the

approach of a vehicle 1667 (e.g., a large truck). A location to the right of the vehicle 100 is blocked due to pedestrians 1671 on a sidewalk at that location. Therefore, those regions may be designated as blocked region 1683 and 1689, respectively. However, a region that is free of objects may be detected (e.g., via the planner system and perception system) in a region 1691. The region 1691 may be designated as an open region 1693 and the planner system may command the drive system to alter the trajectory from trajectory T_{av} to an avoidance maneuver trajectory T_m . The resulting command may cause the vehicle 100 to turn the corner into the open region 1693 to avoid the potential rear-ending by object 1661.

[0163] In concert with the avoidance maneuver into the open region 1693, other safety systems may be activated, such as bladders 1310 on an end of the vehicle 100, seat belt tensioners 1411, acoustic arrays 102, seat actuators 1511, and light emitters 1202, for example. As one example, as the vehicle 1661 continues to approach the vehicle 100 on predicted location L_o , one or more bladders 1301 may be deployed (e.g., at a time prior to a predicted impact time to sufficiently allow for bladder expansion to a deployed position), an acoustic alert may be communicated (e.g., by one or more acoustic beam-steering arrays 102), and a visual alert may be communicated (e.g., by one or more light emitters 1202).

[0164] Planner system may access data representing object types (e.g. data on vehicles such as object 1661 that is predicted to rear-end vehicle 100) and compare data representing the object with the data representing the object types to determine data representing an object type (e.g., determine an object type for object 1661). Planner system may calculate a velocity or speed of an object based data representing a location of the object (e.g., track changes in location over time to calculate velocity or speed using kinematics calculator 384). Planner system may access a data store, look-up table, a data repository or other data source to access data representing object braking capacity (e.g., braking capacity of vehicle 1661). The data representing the object type may be compared with the data representing object braking capacity to determine data representing an estimated object mass and data representing an estimated object braking capacity. The data representing the estimated object mass and the data representing the estimated object braking capacity may be based on estimated data for certain classes of objects (e.g., such as different classes of automobiles, trucks, motorcycles, etc.). For example, if object 1661 has an object type associated with a mid-size four door sedan, than an estimated gross vehicle mass or weight that may be an average for that class of vehicle may represent the estimated object mass for object 1661. The estimated braking capacity may also be an averaged value for the class of vehicle.

[0165] Planner system may calculate data representing an estimated momentum of the object based on the data representing the estimated object braking capacity and the data representing the estimated object mass. The planner system may determine based on the data representing the estimated momentum, that the braking capacity of the object (e.g., object 1661) is exceeded by its estimated momentum. The planner system may determine based on the momentum exceeding the braking capacity, to compute and execute the avoidance maneuver of FIG. 16C to move the vehicle 100 away from the predicted impact zone and into the open region 1693.

[0166] FIG. 17 depicts a top plan view of an example 1700 of an interior of an autonomous vehicle 100. In FIG. 17, an interior 100i of the vehicle 100 may include one or more bench seats 1518 (see seats 1518 in FIG. 15). Each bench seat 1518 may be mounted to a sled 1703 and may include a backrest 1731 and headrests 1729. Each seat 1518 may also include an occupancy sensor O (depicted in dashed line) which may be positioned under the seat 1518 or disposed in a cushion of the seat 1518, for example. The occupancy sensor O may be configured to generate a signal indicative of a passenger being seated on the seat 1518 (e.g., the left seating position or the right seating position of bench seat 1518). The signal generated may be based on an anticipated range of body mass for a passenger (e.g., about 2 kilograms or more). For example, occupancy sensor O may be a pressure switch or other suitable sensor.

[0167] Each bench seat 1518 may include a seat belt 1413 (see seat belts 1413 in FIG. 14), with each seat belt 1413 being coupled with a seat belt tensioner 1411 configured to apply tension T to the belt 1413 based on a signal from a seat belt tensioning system (see 361 in FIG. 14). The seat belt tensioner 1411 may also release the tension T so that the belt 1413 may be in a slack state S when worn by a passenger under normal circumstances (e.g., normal driving operations) that do not require tensioning of the belt (e.g., in anticipation of a collision and/or during emergency and/or evasive maneuvering of vehicle 100). Each belt 1413 may be coupled with an anchor 1721 that may be coupled with the sled 1703 or other structure of the vehicle 100, and a buckle 1723 for inserting into a clasp or the like (not shown).

[0168] Seat belt tensioner 1411 may include but is not limited to an electromechanical structure being configured to apply tension T to the belt 1413, such as winding a portion of the belt 1413 onto a reel the belt 1413 is partially wound on (e.g., using an electric motor and gearing), and to unwind a portion of the belt 1413 from the reel to release the tension T (e.g., to impart slack S to belt 1413).

[0169] Sled 1703 may be configured to mechanically couple with structure of the vehicle 100 (e.g., structure in a crumple zone) that may be deformed due to an impact 1787 of an object 1750 with the vehicle 100 (e.g., due to a collision). An impact force 1517 may be operative to

move the sled 1703 and its seat 1518 from a first position in the interior 100i to a second position in the interior (e.g., towards the center or middle of the interior space of vehicle 100). For example, structure of vehicle 100 that may be deformed or dislodged from the impact 1787 may engage (e.g., press against) the sled 1703 and urge the sled 1703 forward from the first position to the second position. In that a force 1513 generated by the impact 1787 may cause the sled 1703 to accelerate at a rate that may harm passengers on seat 1518, the vehicle 100 may include a structure and/or mechanism to counteract (e.g., act against) the force 1513 by applying a counter force 1515 (see 1513 and 1515 in FIG. 15). Moving the sled 1703 from the first position to the second position may increase a space between passengers seated on seat 1518 and an end of the vehicle 100 at which the impact 1787 occurred. As one example, impact 1787 of object 1750 at a first end of vehicle 100 may occur proximate a first crumple zone having a crumple zone distance $Z1$ between the first end and the sled 1703 when the sled is at the first position. If the sled 1703 is stationary in the vehicle 100 (e.g., not movably mounted), then the crumple zone distance $z1$ may not significantly change. However, sled 1703 is movably mounted in interior 100i and the impact 1787 may drive the sled 1703 forward from the first position to the second position such that the crumple zone distance may increase from $Z1$ to $Z2$ creating a positive increase in crumple zone space ACZ in the interior 100i of the vehicle 100. As damage to the vehicle 100 manifests itself, passengers seated on seat 1518 are being moved away from the impact zone at the first end of the vehicle 100.

[0170] Similarly, an impact 1787 at a second end of the vehicle 100 by an object 1751 may operate to move the sled 1703 from the first position to the second position as described above. Each sled 1703 may act independently of the other sled 1703 such that impacts at both ends of the vehicle 100 may operate to move both sleds 1703 inward from their respective first positions to their respective second positions. Prior to the impact 1787 of the objects 1750 and/or 1751, a planner system (e.g., based on object data from a perception system of the vehicle 100) of the vehicle 100 may command tensioning of the seat belts 1413 using tensioners 1411. Seating positions having occupancy sensors 0 that indicate the seating position is vacant may not have their seat belts 1413 tensioned by its respective tensioner 1411, for example.

[0171] The autonomous vehicle 100 may be configured for driving operations in more than one direction as denoted by arrow 1790 such that the vehicle 100 may not have a front end (e.g., with a hood) or a rear end (e.g., with a trunk). Accordingly, the vehicle 100 may have the first end and the second end as depicted and may perform driving operations with either end facing in the direction of travel of the vehicle 100. Furthermore, the seats 1518 may not have a front or rear designation due the vehicle 100 not having a designated front or rear, for example.

[0172] FIG. 18 depicts a top plan view of another example 1800 of an interior of an autonomous vehicle 100. In example 1800, each sled 1703 includes a pair of separate seats 1518 (e.g., bucket seats). Each seat 1518 may include a headrest 1829, backrest 1831, seat belts 1413, tensioners 1411, anchors 1721 and buckles 1723, for example. The number of seats 1518, the configuration of seats 1518 (e.g., bucket or bench), the orientation of the seats 1518 relative to each other or the vehicle 100 are not limited to the examples in FIGS. 17 and/or 18.

[0173] FIG. 19 depicts a cross-sectional view of an example 1900 of a seat in an autonomous vehicle 100. In example 1900, seat 1518 may be mounted to sled 1703 and the sled 1703 may be movably mounted to a rail 1902. The rail 1902 may be mounted to a substrate 1901 (e.g., a floor of vehicle 100). A ram 1922 may be coupled with the sled 1703 and may be positioned in contact with a structure 1920 of the vehicle 100 (e.g., a bulkhead and/or exterior panel of vehicle 100). The structure 1920 may have one surface facing the interior 100i and another surface facing the exterior 100e of the vehicle 100, for example. As one example, structure 1920 may be a body panel disposed at the first end or the second end of the vehicle 100. Impact 1787 by an object (e.g., 1750 or 1751 of FIG. 17) may cause structure to deform (e.g., bend or crush inward towards the interior 100i of vehicle 100) and move the ram 1922 inward towards the interior 100i and causing the sled 1703 to slide forward (e.g., force 1513) on rail(s) 1902 from the first position to the second position. Prior to the impact 1787, the seat belt 1413 may have already been pre-tensioned T by seat belt tensioner 1411, for example. The ram 1922 may be a component of a crumple zone of the vehicle 100. The ram 1922 may be configured to deform, crumple, deflect or otherwise change shape in a manner configured to absorb a portion of the force from the impact 1787 while urging the sled 1703 forward from the first position to the second position.

[0174] FIG. 20 depicts a top plan view of an example 2000 of a seat coupler and a passive seat actuator of an autonomous vehicle 100. In example 2000, a seat coupler 1511 may be mounted to substrate 1901 and may include a counter force device 2001 (e.g., a spring, a dampener, a shock absorber, an air spring, etc.) coupled with the seat coupler 1511 and coupled 2007 with the sled 1703 via rod 2005. Force 1513 imparted by ram 1922 may be counteracted by the counter force device 2001, thereby producing counter force 1515 which may operate to slow down (e.g., deaccelerate motion of the seat as is it being displaced) the sled 1703 and its seat 1518 to prevent acceleration injury to passengers seated in seat 1518 (e.g., from high G forces due to seat motion caused by the impact 1787). For example, the counter force device 2001 may be a spring, a dampener, a magnetorheological fluid dampener, a shock absorber, a magnetorheological fluid shock absorber, an air spring, or the like. In some examples, the

counter force device 2001 may be configured to operate in compression (e.g., as depicted in FIG. 20), or may be configured to operate in expansion (e.g., as in stretching a spring). In other examples, the impulse (e.g., momentum change) imparted to the seat 1518 due to the collision may be counter acted by a break (e.g., a friction material of a break pad) applied to the rail 1902 by the counter force device 2001. In some examples, a motion signal (e.g., from motion sensor MOT 888 in FIG. 8) indicative of the collision having occurred may be processed (e.g., by processor 1505 of FIG. 15) to generate a fluid control signal configured to change a fluid dynamic characteristic of a magnetorheological fluid of the counter force device 2001 (e.g., in a shock absorber or dampener that includes the magnetorheological fluid). The fluid control signal may be used to modulate or otherwise control the counter force (e.g., a magnitude or magnitude as a function of time) being applied to the sled 1703, for example.

[0175] FIG. 21 depicts a top plan view of an example 2100 of a seat coupler and an active seat actuator of an autonomous vehicle 100. In example 2100, the sled 1703 is coupled 2103 with an active seat actuator 2101 via a rod 2105. The active seat actuator 2101 may be configured to generate a gas that expands a piston coupled with rod 2105 (e.g., via a squib). The active seat actuator 2101 may be configured to receive signals, such as a seat select signal 1512, an arming signal 1514, and a trigger signal 1516. The active seat actuator 2101 may be configured to detonate a squib that drives the rod 2105 forward and moves (e.g., force 1513) the sled 1703 (e.g., and the seat 1518) forward from the first position to the second position, for example.

[0176] A flow diagram 2150 depicts one example of a process for actuating a seat actuator. At a stage 2152 a determination may be made as to whether or not a seat (e.g., seat 1518) has been selected (e.g., 1512 of FIG. 15) for actuation from a first position to a second position (e.g., by seat selector 1519 in seat actuator system 363 based on interior data 323 of FIG. 15). If the seat has not been selected, then a NO branch may be taken and flow 2150 may terminate (e.g., END). If the seat has been selected, then a YES branch may be taken to a stage 2154 where a determination may be made as to whether or not an arming signal (e.g., 1514 of FIG. 15) has been received. If the arming signal has not been received, then a NO branch may be taken and flow 2150 may transition to another stage, such as back to the stage 2152, for example. On the other hand, if the arming signal has been received, then a YES branch may be taken to a stage 2156 where a determination may be made as to whether or not a trigger signal has been received (e.g., 1516 of FIG. 15). If the trigger signal has not been received, then a NO branch may be taken and flow 2150 may transition to another stage, such as back to the stage 2152, for example. If the trigger signal has been received (e.g., at active seat actuator 2101), then a YES branch may be taken to a stage 2158 where the seat (e.g., 1518) may be actuated from the first

position in the interior of the vehicle 100 to a second position (e.g., further inward in the interior 100i) in the interior of the vehicle 100. For example, at the stage 2158 a pyrotechnic device in the active seat actuator 2101 may be electronically detonated to generate a gas that drives the rod 2105 outward to move the seat 1518 forward.

[0177] FIG. 22 depicts one example 2200 of a seat belt tensioner in an interior safety system of an autonomous vehicle 100. In example 2200, seat belt tensioner 1411 may include a drive unit 2202 (e.g., an electric motor, a linear motor, a gas driven motor, etc.) having gears 2204 being configured to mesh with gears 2203 of a belt reel 2201. A rotation 2206 of drive unit 2202 may be configured to cause belt reel 2201 to rotate 2207 in a direction configured to cause the belt reel 2201 to wrap seat belt 1413 around the belt reel 2201 to apply tension T to the belt 1413. Rotation of drive unit 2202 in a direction opposite to the arrow for 2206 may be configured to cause the belt reel 2201 to also rotate in a direction opposite of arrow 2207; thereby, causing the belt reel 2201 to unwind belt 1413 to release the tension T so that slack S is applied to the belt 1413, for example. A housing 2210 of the seat belt tensioner 1411 may include an aperture thorough which the seat belt 1413 may enter and exit the housing.

[0178] The seat belt tensioner 1411 may be configured to apply tension T or slack S to belt 1413 via belt selector 1417 (e.g., coupled with processor 1405 of FIG. 14). The belt tensioner select signal 1412, the trigger signal 1414 and the release signal 1416 may be received by the belt selector 1417 to control operation of the seat belt tensioner 1411 (e.g., applying tension or slack).

[0179] A flow diagram 2250 depicts one example of seat belt tensioner functionality. At a stage 2252 a determination may be made as to whether or not a seat is selected (e.g., a seat the seat belt tensioner 1411 is associated with). If the seat is not selected, then a NO branch may be taken and flow 2250 may terminate. In other examples, flow 2250 may cycle back to the stage 2252. If the seat is selected, then a YES branch may be taken to a stage 2254. At the stage 2254 a determination may be made as to whether or not a trigger has been detected (e.g., a signal/data to activate the seat belt tensioner 1411). If the trigger is not detected, then a NO branch may be taken and flow 2250 may transition back to the stage 2252, for example. If the trigger is detected, then a YES branch may be taken to a stage 2256. At the stage 2256, tension T may be applied to a seat belt (e.g., 1413). The stage 2256 may transition to a stage 2258 where a determination may be made as to whether or not a release signal has been received (e.g., a signal/data to release the tension T). If the release signal has not been received, then a NO branch may be taken and flow 2250 may cycle back to the stage 2256 where tension T will continue to be applied to the seat belt. If the release signal has been received, then a YES branch

may be taken to a stage 2260 where slack S may be applied to the belt to release the tension T. The stage 2260 may transition to another stage in flow 2250, such as back to the stage 2252, for example.

[0180] FIG. 23 depicts an example 2300 of point of impact preference maneuvering in an autonomous vehicle 100. The autonomous vehicle 100 may be configured for driving operation in more than one direction as denoted by arrow 2390. In example 2300, vehicle 100 may be configured (e.g., through mechanical structures designed into the vehicle 100) to include a first crumple zone 2321 positioned at the first end (1st End) of the vehicle 100 and a second crumple zone 2322 positioned at the first end (2nd End) of the vehicle 100, for example. The first and second crumple zones 2321 and 2322 may also be configured to overlap with the first offset (1st Offset), the second offset (2nd Offset), the third offset (3rd Offset) and the fourth offset (4th Offset) as depicted in FIG. 23. The planner system based on the structure of the first and second crumple zones 2321 and 2322 (e.g., impact force absorbing and/or mechanical impact deformation characteristics of crumple zones 2321 and 2322), may be configured to rank crumple zone point of impact preferences from highest to lowest as: the highest being 1st End or the 2nd End; the next highest being the 1st Offset, the 2nd Offset, the 3rd Offset or the 4th Offset; and the lowest being the 1st Side or the 2nd Side. Crumple zones 2321 and 2322 may include structure (e.g., sled 1703 and ram 1922) being configured to move seats 1518 disposed in the interior 100i of the vehicle 100 from the first position to the second position (see seat actuator system 363 in FIG. 15) using passive (see FIGS. 19 and 20) and/or active (see FIG. 21) seat actuators.

[0181] The planner system may cause the drive system 326 to maneuver the vehicle 100 to orient the vehicle 100 relative to the object 2350 such that the object 2350 may impact the vehicle 100 at a preferred point of impact selected by the planner system (e.g., based on crumple zone positions, crumple zone distances, bladder positions, seat positions, etc.). The planner system may cause the bladder selector to select bladders (see 1317 and 1310 in FIG. 13A) positioned proximate the preferred point of impact to be deployed prior to the impact of the object with the vehicle 100. Seat belts 1413 may be pre-tensioned prior to bladder deployment, for example. In some examples, the planner system may rank point of impact preferences based on bladder positions and crumple zone distances described in reference to FIG. 17, the crumple zone (2321, 2322) locations described in reference to FIG. 23, or both. Bladder data (see 1319 in FIG. 13A) may include data representing bladder positions on the vehicle 100 and other data associated with each bladder, including but not limited to deployment time, size, location, etc., for example.

[0182] Further to the example 2300, systems of autonomous vehicle 100 may have detected and may have determined that an object 2350 is on a collision course for impact with the vehicle 100 (e.g., based on a predicted location L_o of the object 2350) at a predicted point of impact 2301 along a first side (1st Side) in quadrant 4. For example, the predicted point of impact 2301 may be based on the predicted location L_o and an orientation of the vehicle 100 relative to the object 2350. The planner system in conjunction with the perception system, localizer system and sensor system may compute a predicted impact time ($T_{im\ pact}$) for the object 2350 to impact the vehicle 100 at the predicted point of impact 2301. The planner system may calculate, based on data from the perception system and the localizer system, estimated times and/or locations to activate one or more interior (e.g., seat belt tensioners 1411) and/or exterior safety systems of the autonomous vehicle 100. For example, the planner system may estimate the predicted impact time ($T_{im\ pact}$) as a function of changes in location L of the object 2350 and changes in velocity V of the object 2350 over time (e.g., $T_{im\ pact} \approx \Delta L / \Delta V$).

[0183] The planner system may be configured, based on the predicted impact time, to determine if there is sufficient time before the impact to activate the one or more interior and/or exterior safety systems of the autonomous vehicle 100. As one example, an acoustic alert may be activated for one or more estimated threshold locations 2320 (e.g., $T_1 - T_3$). As the distance between the object 2350 and the vehicle 100 decreases, a visual alert may be activated for one or more estimated threshold locations 2330 (e.g., $t_1 - t_3$).

[0184] If the acoustic and/or visual alerts are unsuccessful at causing the object 2350 to alter its trajectory or otherwise take action to avoid the predicted collision, then the planner system may activate other safety systems of the vehicle 100. Prior to activating the other safety systems (e.g., interior and/or exterior safety systems), the planner system may determine if there is sufficient time prior to the predicted time of impact to successfully activate a selected safety system. For example, the planner system may determine if there is sufficient time prior to the predicted time of impact to successfully activate a seat actuator 2101 (e.g., $T_{actuate\ 2316}$) and/or a seat belt tensioner 1411 (e.g., $T_{tension\ 2312}$). As another example, the planner system may determine that there is sufficient time to activate the seat actuator 2101 and the seat belt tensioner 1411 and may command the interior safety system 322 to activate the seat belt tensioner 1411 first to prepare passengers for the activation of the seat actuator 2101.

[0185] As one example, the planner system may compare a time to maneuver the vehicle 100 ($T_{manuever}$) to an orientation to re-position the point of impact to coincide with a preferred point of impact preference. In the example 2300, the preferred point of impact preference may be to maneuver the vehicle 100 to receive the impact at the second end (2nd End) as the highest

preference, the fourth offset (4th Offset) or the third offset (3rd Offset) as the next highest preference, and the first side (1st Side) as the lowest preference. The planner system may determine that T_{manuever} is less than T_{impact} (e.g., there is sufficient time to execute the maneuver) and may command the drive system to execute the maneuver. Line 2314 denotes one or more points in time that are less than T_{impact} where the vehicle 100 may be re-oriented and/or maneuvered prior to an impact with the object 2350 (e.g., where $T_{\text{manuever}} < T_{\text{impact}}$). For example, maneuvering the vehicle 100 to receive the impact at the second end (2nd End) as opposed to the original predicted point of impact 2301 on the first side (1st Side) may protect passengers of the vehicle 100 from a potential side impact collision were crumple zone distances may be less than crumple zone distances at the second end (2nd End) and to position the crumple zone structure 2322 (e.g., including ram 1922 and/or sled 1703) between the passengers and the object 2350.

[0186] In conjunction with a maneuver by the drive system, the planner system may activate the seat belt tensioning system 361 to tighten seat belts 1413 in anticipation of the maneuver and/or of the impact of the object 2350. Line 2312 denotes one or more points in time that are less than T_{impact} where the seat belt tensioning system 361 may be activated to tension T one or more seat belts 1413 (e.g., where $T_{\text{tension}} < T_{\text{impact}}$), for example. Line 2316 denotes one or more points in time that are less than T_{impact} where the seat actuator 2101 may move the sled 1703 (e.g., and the seats 1518 connected with it) from the first position to the second position in the interior 100i of the vehicle 100 (e.g., where $T_{\text{actuate}} < T_{\text{impact}}$), for example.

[0187] The planner system may activate one or more selected bladders 1310 (e.g., based on the bladder point of impact preference) that may be oriented to receive the impact based on the maneuvering of the vehicle 100, for example. Line 2310 denotes one or more points in time that are less than T_{impact} where the bladder system 369 may be activated to deploy one or more selected bladders 1310 (e.g., where $T_{\text{deploy}} < T_{\text{impact}}$). Lines 2310, 2312, 2314 and 2316 may represent probable times (e.g., based on their arcuate shapes) relative to T_{impact} because the predicted location L_o of object 2350 may change as the object 2350 moves closer to vehicle 100. The predicted point of impact 2301 may also change with the predicted location L_o of object 2350, the predicted next location of the object 2350, the orientation of the vehicle 100, the location of the vehicle 100, etc., for example. The planner system, localizer system, and perception system may, in real-time, re-calculate data representing the object 2350 and the vehicle 100 to update changes in the predicted location L_o of object 2350 and the predicted point of impact 2301, for example.

[0188] FIG. 24 depicts another example 2400 of point of impact preference maneuvering in an autonomous vehicle 100. In example 2400 the object 2350 (see FIG. 23) has moved closer to the autonomous vehicle 100 and is depicted as being very close to an actual impact with the vehicle 100. Prior to the impact, the planner system may command the drive system to maneuver the vehicle 100 to orient the second end (2nd End) of the vehicle 100 to receive the impact from the object 2350. For example, the drive system may cause the wheels 852 to be steered (e.g., via the steering system) from an initial position 852i to a new position 852m and may cause the propulsion system to rotate the wheels 852 in a direction configured to rotate 2410 the vehicle 100 to orient the second end (2nd End) of the vehicle 100 to receive the impact from the object 2350.

[0189] The re-orientation of the vehicle 100 may be configured to place the crumple zone 2322 in position to absorb the impact of the object 2350, to place bladders 1310 disposed at the second end (2nd End) to absorb the impact of the object 2350, to place the sled 1703 in position to move from the first position to the second position (e.g., using passive or active actuation), or some combination of the foregoing, for example. In example 2400, the bladders 1310 are depicted in the un-deployed state, but may be subsequently activated to the deployed state in sufficient time prior to the impact of the object (e.g., $T_{\text{deploy}} < T_{\text{impact}}$). Seat belt tensioners 1411 (not shown) may be activated prior to deployment of the bladders 1310.

[0190] In example 2400, if there is insufficient time to maneuver the vehicle 100 to take the impact at the second end (2nd End), but there is sufficient time to maneuver the vehicle 100 to take the impact at the fourth offset (4th Offset), then the planner system may be configured to cause the drive system to orient the vehicle 100 to receive the impact at the fourth offset (4th Offset) (e.g., the time to rotate 2410 to the 4th Offset is less than the time to rotate 2410 to the 2nd End).

[0191] Further to example 2400, after the collision occurs, the vehicle 100 may be displaced (e.g., moved or pushed) due to the impact forces imparted by the object 2350. Post-impact, the planner system may command deployment of some or all of the bladders 1310 that have not already been deployed, in the event the vehicle 100 is pushed into other objects (e.g., an object 2490) in the environment, such as pedestrians, other vehicles, road infrastructure, and the like, for example. Motion sensors in the sensor system and/or in the bladder engine 1311 may detect motion 2470 due to the impact of the object 2350 with the vehicle 100 and data representing signals from the motion sensor(s) may be used by the processor to determine which of the un-deployed bladders 1310 to deploy, post-impact. The planner system may access bladder data 1319 and/or data representing crumple zone characteristics (e.g., crumple zone force absorbing

capacity, crumple zone length, crumple zone strength, crumple zone location, crumple zone preference rank, etc.) to determine if a predicted impact point on the vehicle coincides with a bladder point of impact preference and/or a crumple zone point of impact preference, and command the drive system to maneuver the vehicle 100 to re-orient the vehicle 100 to receive an impact at the highest ranking preference location external to the vehicle 100 based one or more factors including but not limited to on T_{impact} , T_{deploy} , T_{manuever} , T_{tension} , T_{actuate} , occupied passenger positions (e.g., from seat occupancy sensors O) in seats 1518 disposed in the interior 100i, etc., for example.

[0192] A post-impact collision of the vehicle 100 with object 2490 may also activate other interior safety systems, such as moving a sled 1703 disposed proximate the first end (1st End) of the vehicle 100 from the first position to the second position, for example. If seats 1518 (not shown) on the sled 1703 are occupied, then seat belt tensioners 1411 may be activated to tension T seat belts 1413 at occupied seat positions, for example.

[0193] FIG. 25 depicts an example of a flow diagram 2500 for implementing an interior safety system in an autonomous vehicle 100. At a stage 2502 a trajectory of an autonomous vehicle in an environment external to the autonomous vehicle may be calculated based in data representing a location of the autonomous vehicle in the environment. For example, the stage 2502 may access or otherwise receive pose data 2571 and/or other data representative of the location of the autonomous vehicle in the environment. The stage 2502 may generate data representing a trajectory 2573 of the autonomous vehicle.

[0194] At a stage 2504 a location of an object in the environment may be determined (e.g., by a perception system) using sensor data 2575, for example. The stage 2504 may generate data representing the location of the object 2579. The data representing the location of the object 2579 may include data representing a predicted rate of motion 2581 of the object relative to the location of the object in the environment. For example, if the object has a static object track indicative of no motion in the environment, then the predictive rate of motion 2581 may be zero. However, if the object track of the object is dynamic and the object classification is an automobile, then the predicted rate of motion 2581 may be non-zero.

[0195] At a stage 2506 a predicted next location of the object in the environment may be calculated based on the predicted rate of motion 2581. The stage 2506 may generate data representing the predicted next location 2583.

[0196] At a stage 2508, probabilities of impact between the object and the autonomous vehicle may be predicted based on the predicted next location 2583 and the trajectory of the

autonomous vehicle 2573. The stage 2508 may generate data representing the probabilities of impact 2585.

[0197] At a stage 2510, a predicted point of impact of the object with the autonomous vehicle may be calculated based on the probabilities of impact 2585. The stage 2510 may generate data representing the predicted point of impact 2587 (e.g., a location on the autonomous vehicle the object is predicted to impact at). The predicted point of impact 2587 may be associated with a point of impact rank 2589 associated with a safety system of the autonomous vehicle (e.g., a bladder system, a crumble zone, a light emitter, an acoustic array, a seat belt tensioning system, a seat actuation system and a drive system, etc.).

[0198] At a stage 2512, the autonomous vehicle may be maneuvered, based on the point of impact rank 2589 to a preferred point of impact with the object. The preferred point of impact may include another point of impact rank 2591 that is different than the point of impact rank 2589 (e.g., the another point of impact rank 2591 may have a higher preferred ranking than the point of impact rank 2589). The stage 2512 may cause (e.g., by communicating data and/or signals) a safety system activator 2593 of the autonomous vehicle to activate one or more of the safety systems of the autonomous vehicle associated with the preferred point of impact. For example, the safety system activator 2593 may activate one or more interior safety systems, including but not limited to seat actuators and seat belt tensioners may be activated (e.g., in a preferred sequence). In conjunction with the activation of the one or more interior safety systems, the safety system activator 2593 may activate one or more exterior active safety systems (e.g., bladders, light emitters, acoustic beam steering arrays, etc.). In some examples, flow 2500 may bypass the stage 2512 (e.g., optionally, skip the stage 2512) and may cause the safety system activator 2593 to activate one or more internal and/or external safety systems without having to maneuver the vehicle 100.

[0199] FIG. 26 depicts another example of a flow diagram 2600 for implementing an interior safety system in an autonomous vehicle 100. At a stage 2602, one or more passengers may be received by the autonomous vehicle 100 (e.g., the passengers may board the vehicle 100). At a stage 2604 a determination may be made as to whether or not the passengers have been seated (e.g., a mass of a passenger sensed by a seat occupancy sensor O of a seat 1518 in FIGS. 17 and 18). If one or more passengers are not seated, then a NO branch may be taken to a stage 2605 where the passengers may be autonomously instructed (e.g., by autonomous vehicle system 101 using an audio recording) to take a seat (e.g., to please be seated and buckle up). The stage 2605 may cycle back to the stage 2604 until all passengers are seated and the YES branch may be taken from the stage 2604 to a stage 2608.

[0200] At the stage 2608, a determination may be made as to whether or not seat belts of the passengers are fastened (e.g., as detected by a seat belt sensor in a buckle 1723 of a seat belt 1413). The seat belt sensor may generate a signal indicative of the seat belt being fastened (e.g., buckled or buckled-up), for example. The seat belt sensor may be a switch actuated by buckling of the seat belt. If one or more passengers have not fastened their seat belt, then a NO branch may be taken to a stage 2609. At the stage 2609 the passengers may be autonomously instructed (e.g., by autonomous vehicle system 101 using an audio recording) to fasten their seat belts so that the autonomous vehicle 100 may embark on its destination. The stage 2609 may cycle back to the stage 2608 until all passengers have complied by fastening their seat belts.

[0201] At a stage 2610, tension T may be applied to the seat belts of the passengers to notify the passengers the autonomous vehicle 100 is about to embark for its destination (e.g., the tightening may be accompanied by an audio recording). At a stage 2612, after the autonomous vehicle 100 has embarked, the tension T may be released (e.g., slack S may be applied to the seat belts).

[0202] At a stage 2614, the autonomous vehicle 100 may autonomously navigate to a destination. At a stage 2616 a determination may be made as to whether or not the autonomous vehicle 100 has arrived at its intended destination (e.g., via data from the localizer system and/or the perception system). If a NO branch is taken, then flow 2600 may cycle back to the stage 2614. If a YES branch is taken, then flow 2600 may continue to a stage 2618.

[0203] At the stage 2618, tension T may be applied to the seat belts of passengers to provide notice that the autonomous vehicle 100 has arrived at its intended destination (e.g., by autonomous vehicle system 101 using an audio recording). At a stage 2620, the tension T may be released from the seat belts (e.g., seat belts have slack S applied to them) in preparation of the passengers disembarking from the autonomous vehicle 100. At a stage 2622, the passengers may be instructed to disembark from the autonomous vehicle 100 (e.g., by autonomous vehicle system 101 using an audio recording).

[0204] One or more stages of the flow 2600 may not be performed (e.g., executed on a processor of the vehicle 100), such as stages 2616 - 2622, for example. The stages of flow 2600 may occur in a sequence different than that depicted in FIG. 26.

[0205] Although the foregoing examples have been described in some detail for purposes of clarity of understanding, the above-described conceptual techniques are not limited to the details provided. There are many alternative ways of implementing the above-described conceptual techniques. The disclosed examples are illustrative and not restrictive.

What is Claimed Is:

1. A method for robotic vehicle internal safety system activation, comprising:
 - detecting that a seat of an autonomous vehicle is occupied;
 - detecting that a seat belt coupled with the seat is fastened;
 - applying, by a belt tensioner coupled with the seat belt, a first tension to seat belt;
 - autonomously navigating the autonomous vehicle toward a destination;
 - identifying an occurrence of a safety event from a plurality of safety related events, wherein the plurality of safety related events include a breaking event, and an acceleration event;
 - increasing, by the belt tensioner, the first tension to a second tension based, at least in part, on the occurrence of the safety event; and
 - reducing, by the belt tensioner, during the navigating, the second tension to the first tension.

2. The method of Claim 1 further comprising determining that an avoidance maneuver has completed and based, at least in response to determining that the avoidance maneuver has completed, reducing, by the belt tensioner, during the navigating, the second tension to the first tension.

3. The method of Claim 2 further comprising:
 - releasing, by the belt tensioner, after reaching the destination, the tension from the seat belt.

4. The method of Claim 2, wherein the detecting that the autonomous vehicle has reached the destination further comprises:
 - receiving, at a perception system of the autonomous vehicle, data representing a sensor signal, the sensor signal being generated by a sensor system of the autonomous vehicle;
 - generating at the perception system, based at least in part on the sensor signal, data representing object data indicative of an environment external to the autonomous vehicle;
 - receiving, at a localizer system of the autonomous vehicle, data representing location data associated with a location of the autonomous vehicle in the environment;
 - generating, at the localizer system, based at least in part on the location data, data representing position and orientation data; and

comparing, at a planner system of the autonomous vehicle, the object data with the position and orientation data to determine that the autonomous vehicle has reached the destination.

5. The method of Claim 1, where the detecting that the seat of the autonomous vehicle is occupied further comprises:

receiving data representing a sensor signal from an occupancy sensor coupled with the seat; and

determining, based at least in part on the sensor signal, the seat is occupied.

6. The method of Claim 1, where the detecting that the seat belt coupled with the seat is fastened further comprises:

receiving data representing a sensor signal from a seat belt sensor being configured to sense fastening of the seat belt; and

determining, based at least in part on the sensor signal, the seat belt is fastened.

7. The method of Claim 1, wherein the applying by the belt tensioner further comprises:

receiving, at the belt tensioner, data representing a belt tensioner select signal indicative of the belt tensioner being selected to apply tension to the seat belt; and

receiving, at the belt tensioner, data representing a trigger signal being configured to cause the belt tensioner to apply tension to the seat belt.

8. The method of Claim 1, wherein the releasing by the belt tensioner further comprises:

receiving, at the belt tensioner, data representing a release signal, the release signal being configured to cause the belt tensioner to release the tension from the seat belt.

9. A method for robotic vehicle internal safety system activation, comprising:

determining, based at least in part on data representing a location of an autonomous vehicle in an environment, data representing a trajectory of the autonomous vehicle in the environment;

determining data representing a location of an object in the environment, the object having an object track and an object classification;

predicting a collision between the object and the autonomous vehicle based at least in part on the data representing the location of the object and the data representing the trajectory of the autonomous vehicle; and

causing activation of an interior safety system of the autonomous vehicle at a parametric range in which the collision is predicted, wherein causing activation of the interior safety system includes deaccelerating, by a counter force device, motion of a seat while the seat is being displaced from a first position internal to the autonomous vehicle to a second position internal to the autonomous vehicle.

10. The method of Claim 9, wherein the seat is mounted to a sled, and wherein the sled is coupled to the counter force device.

11. The method of Claim 10 and further comprising:
applying, by a belt tensioner, tension to a seat belt coupled to the seat, the belt tensioner being coupled to the seat belt.

12. The method of Claim 9, wherein causing activation of the interior safety system comprises:
moving, by an active seat actuator, the seat from the first position internal to the autonomous vehicle to the second position internal to the autonomous vehicle, the active seat actuator being coupled to the seat.

13. The method of Claim 12 and further comprising:
applying, by a belt tensioner, tension to a seat belt coupled to the seat, the belt tensioner being coupled to the seat belt.

14. The method of Claim 9, wherein causing activation of the interior safety system comprises:
applying, by a belt tensioner, tension to a seat belt coupled to a seat disposed internal to the autonomous vehicle, the belt tensioner being coupled to the seat belt.

15. The method of Claim 9, wherein the parametric range includes a predicted impact time associated with the collision between the object and the autonomous vehicle.

16. The method of Claim 15 and further comprising:
applying, by a belt tensioner, prior to the predicted impact time, tension to a seat belt coupled to a seat disposed internal to the autonomous vehicle, the belt tensioner being coupled to the seat belt.
17. The method of Claim 15 further comprising:
moving, by an active seat actuator, prior to the predicted impact time, the seat from the first position internal to the autonomous vehicle to the second position internal to the autonomous vehicle, the active seat actuator being coupled to the seat.
18. The method of Claim 9, wherein the counter force device is one or more of a spring, a dampener, or a shock absorber that is coupled to the seat.
19. The method of Claim 18, wherein the counter force device includes a magnetorheological fluid.
20. The method of Claim 19 and further comprising:
applying, during the moving, a fluid control signal to the magnetorheological fluid, the fluid control signal being configured to change a fluid dynamic characteristic of the magnetorheological fluid.

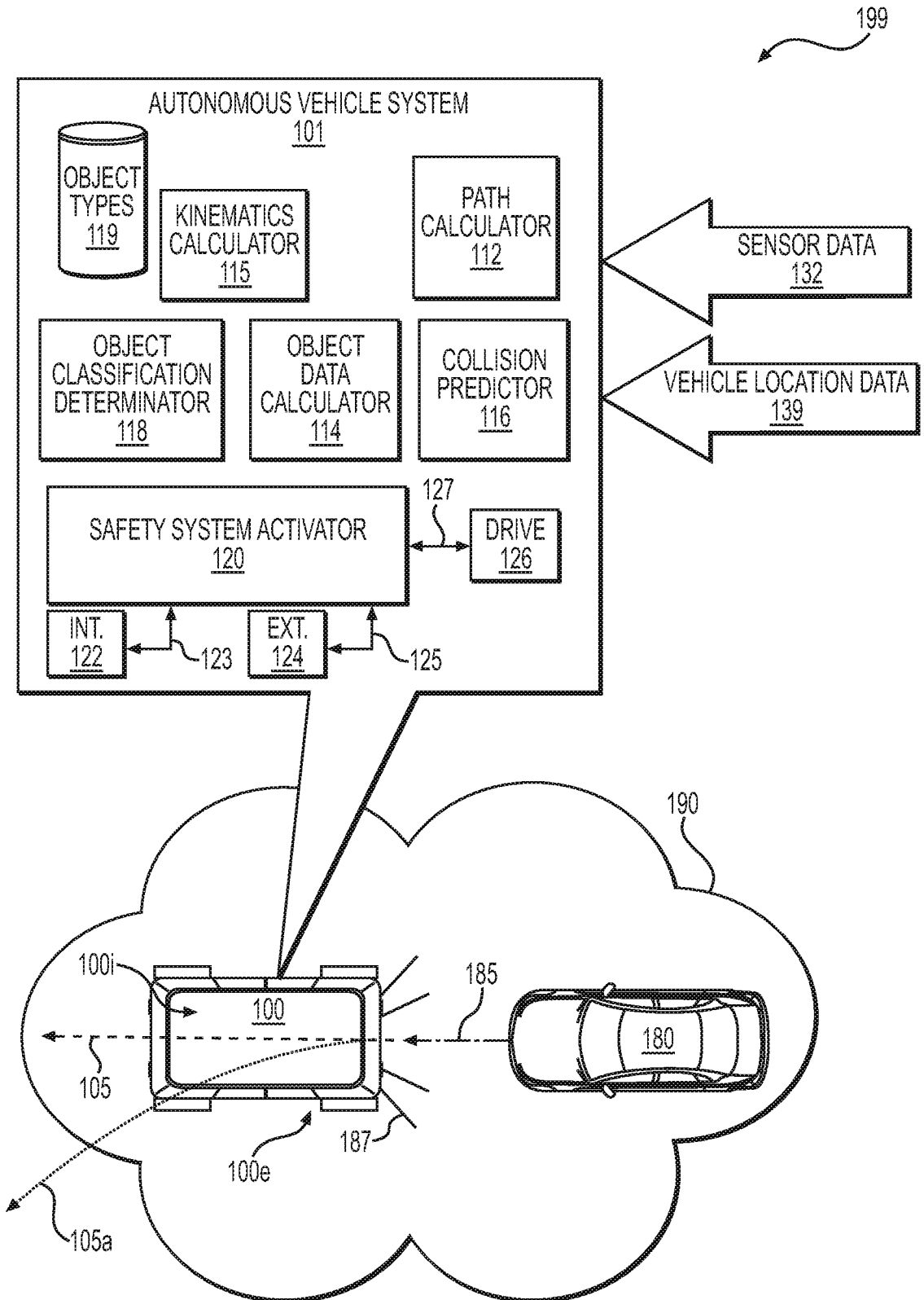

FIG. 1

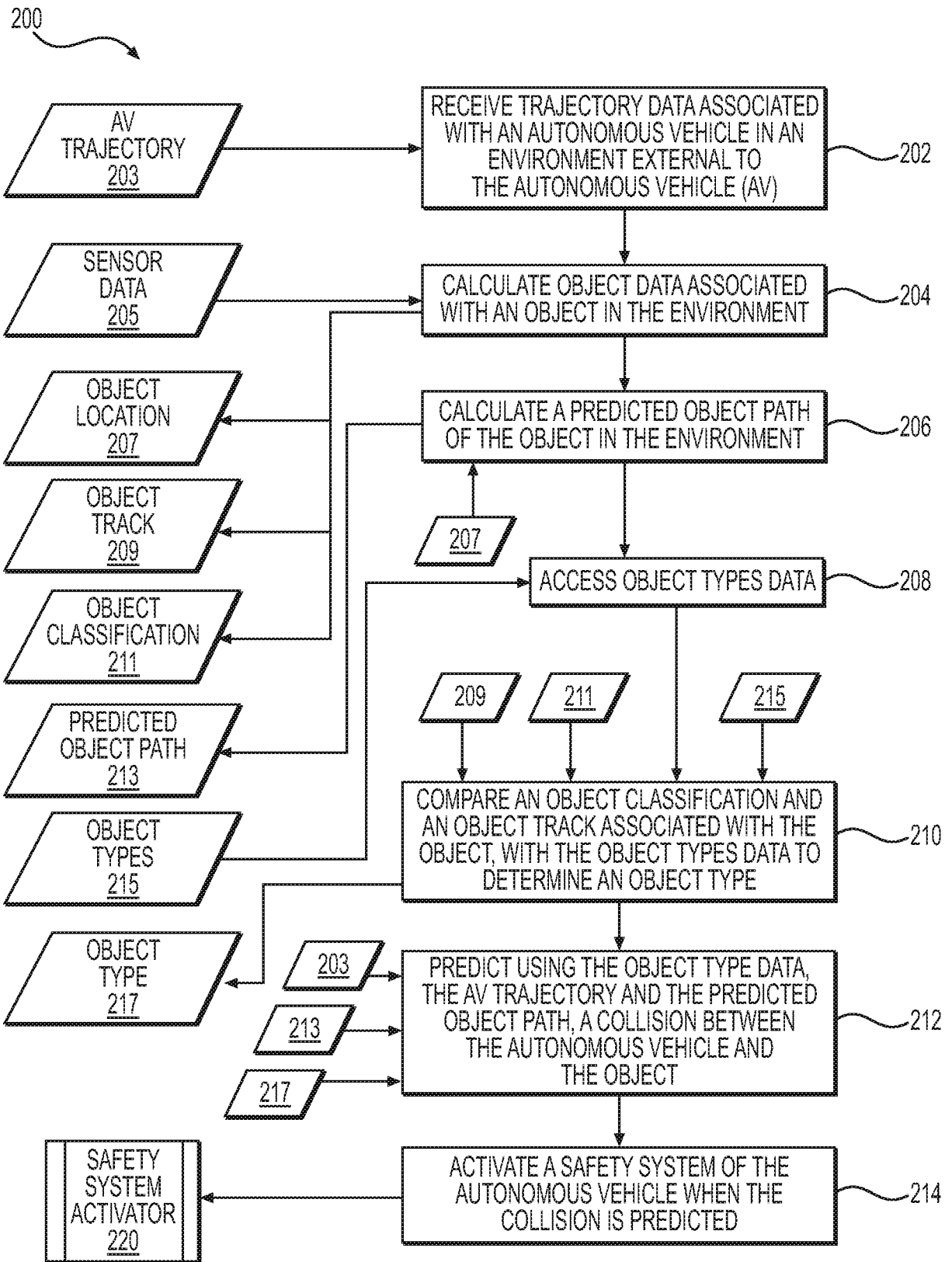

FIG. 2A

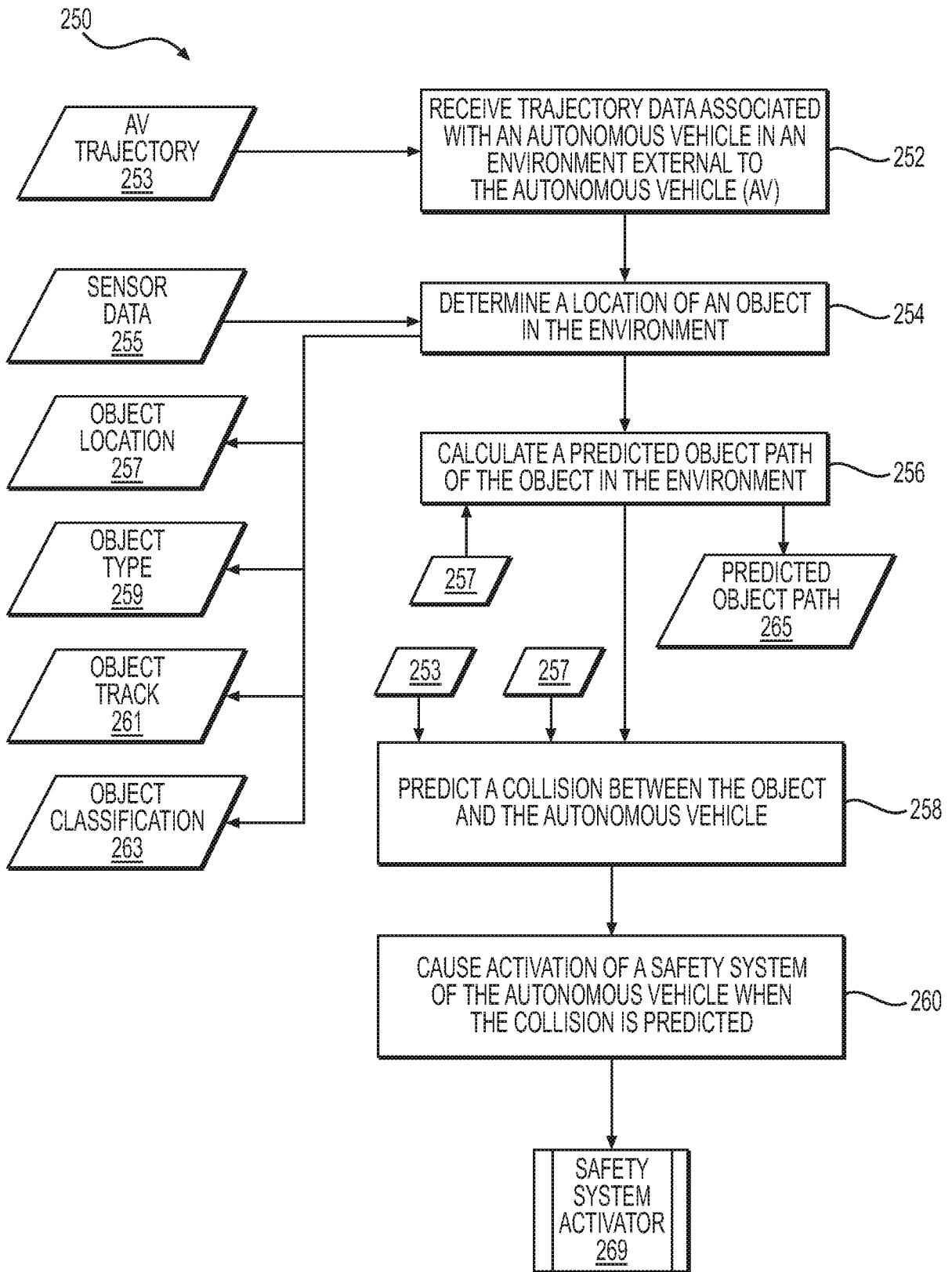

FIG. 2B

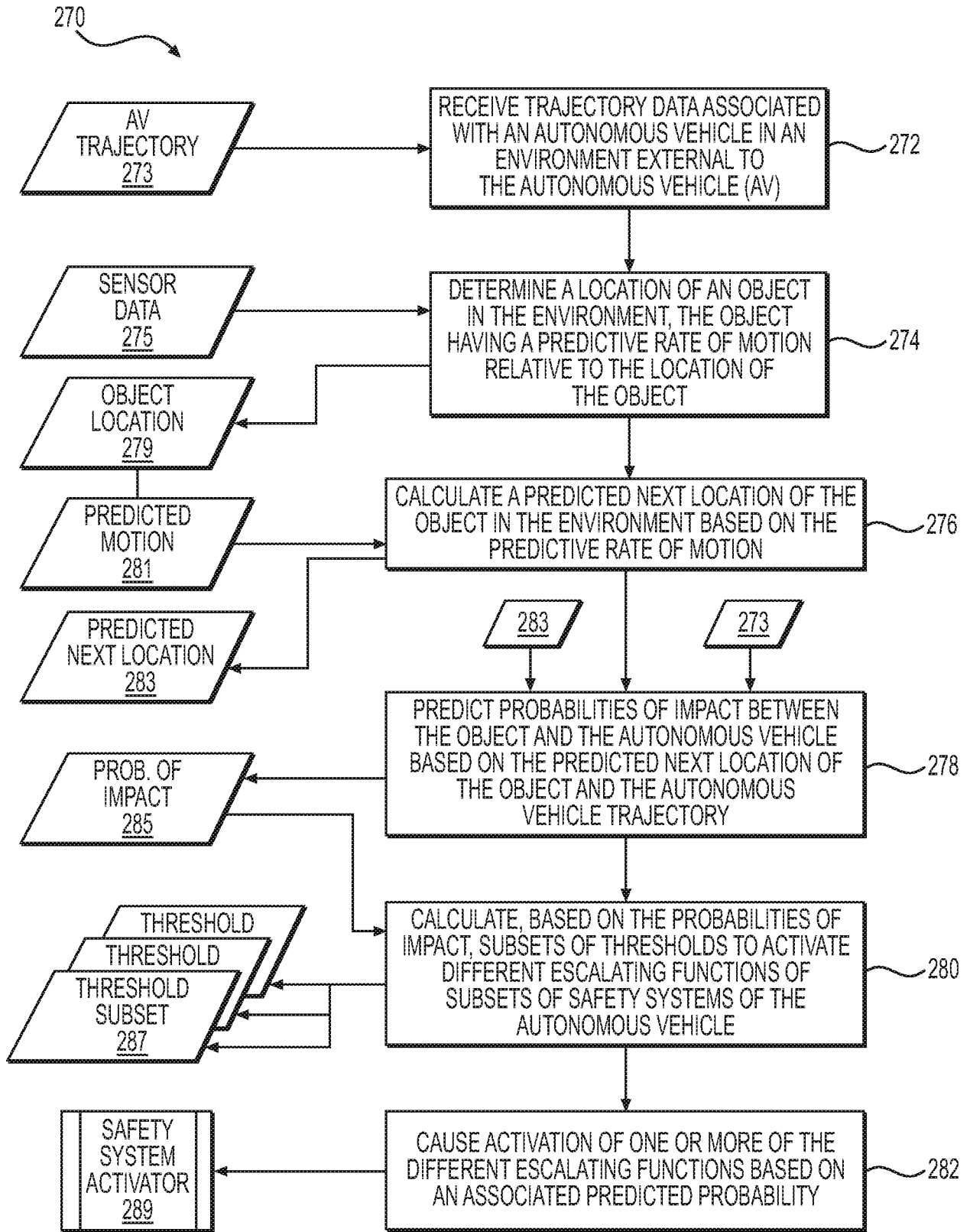

FIG. 2C

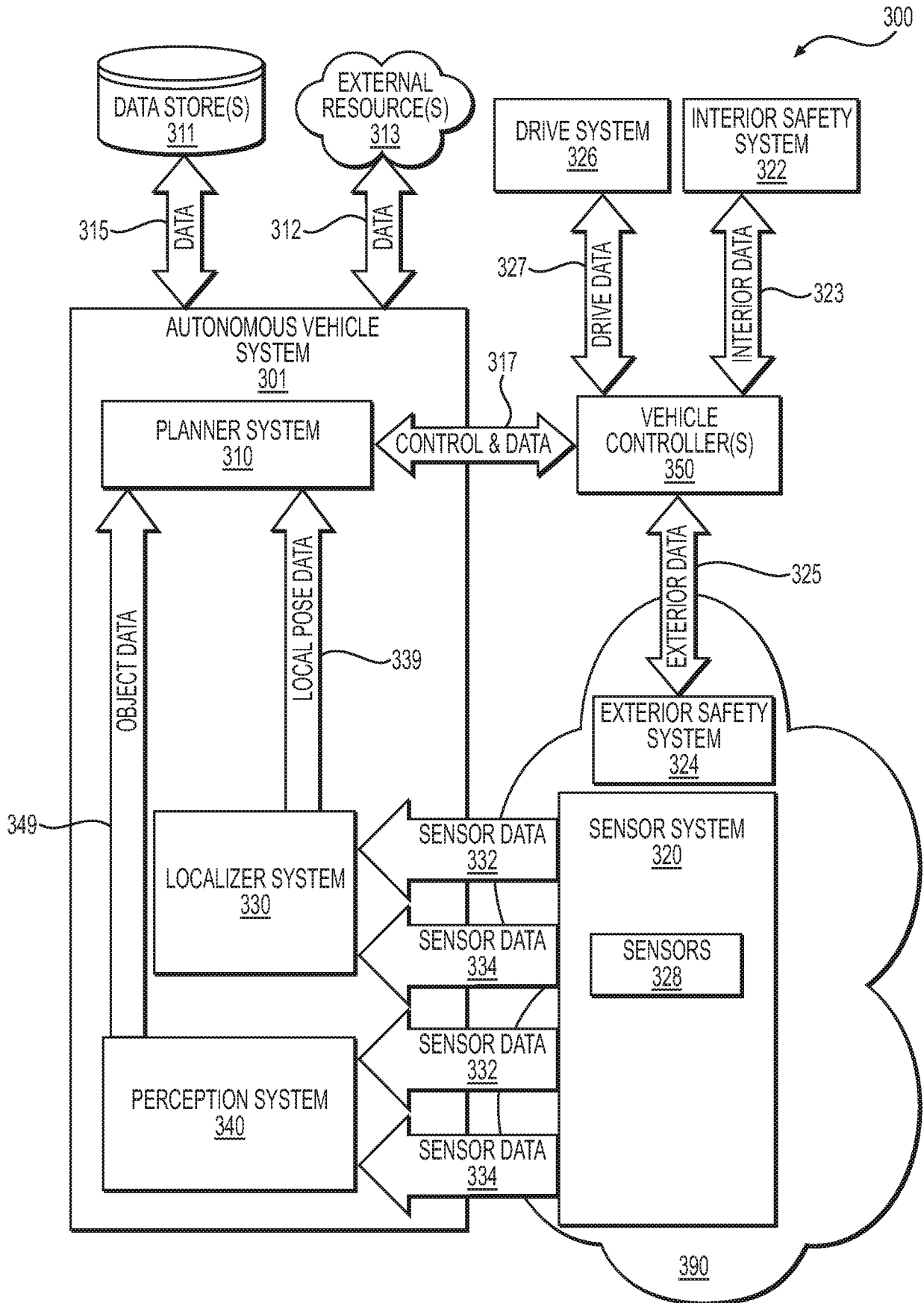

FIG. 3A

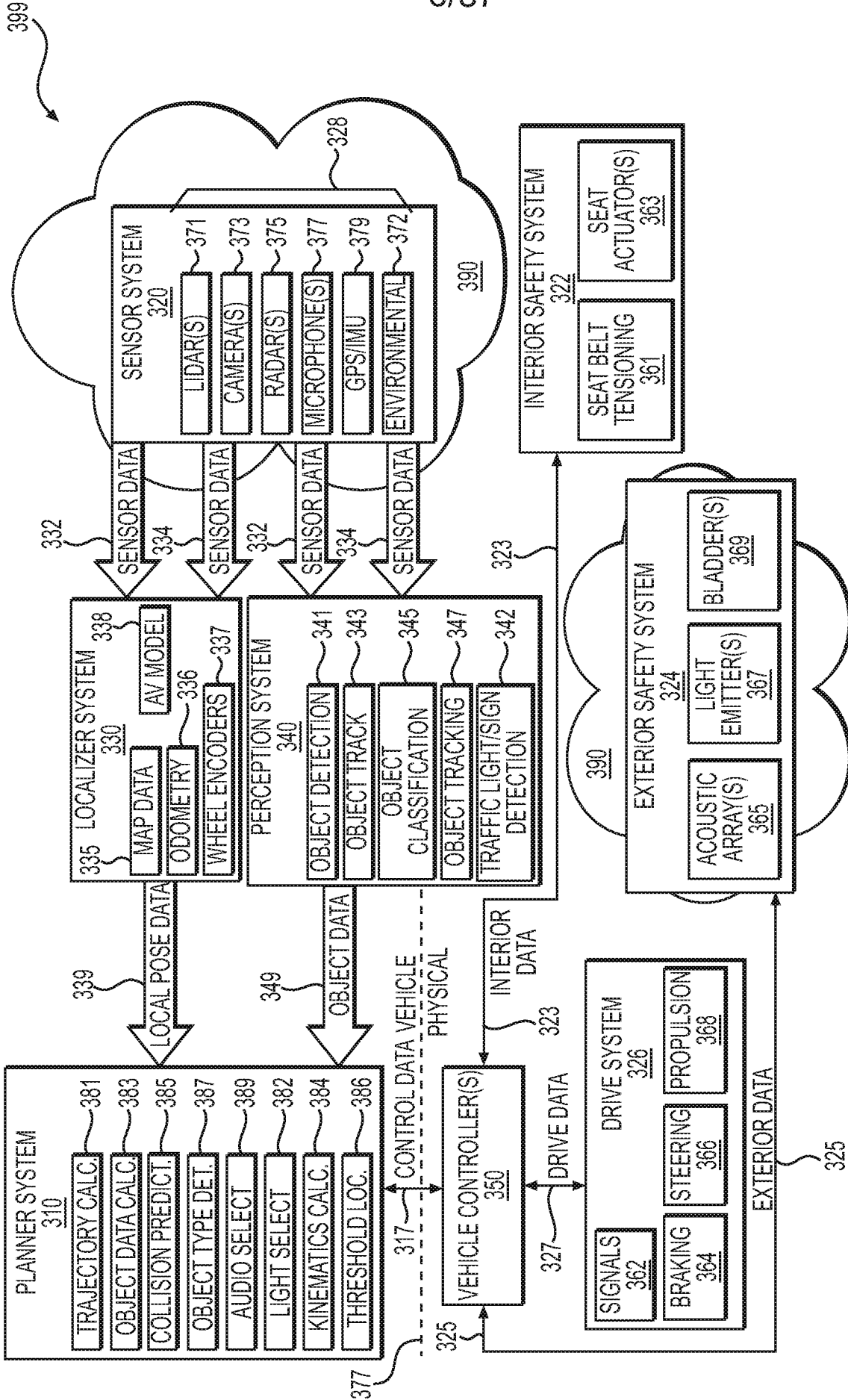

FIG. 3B

7/37

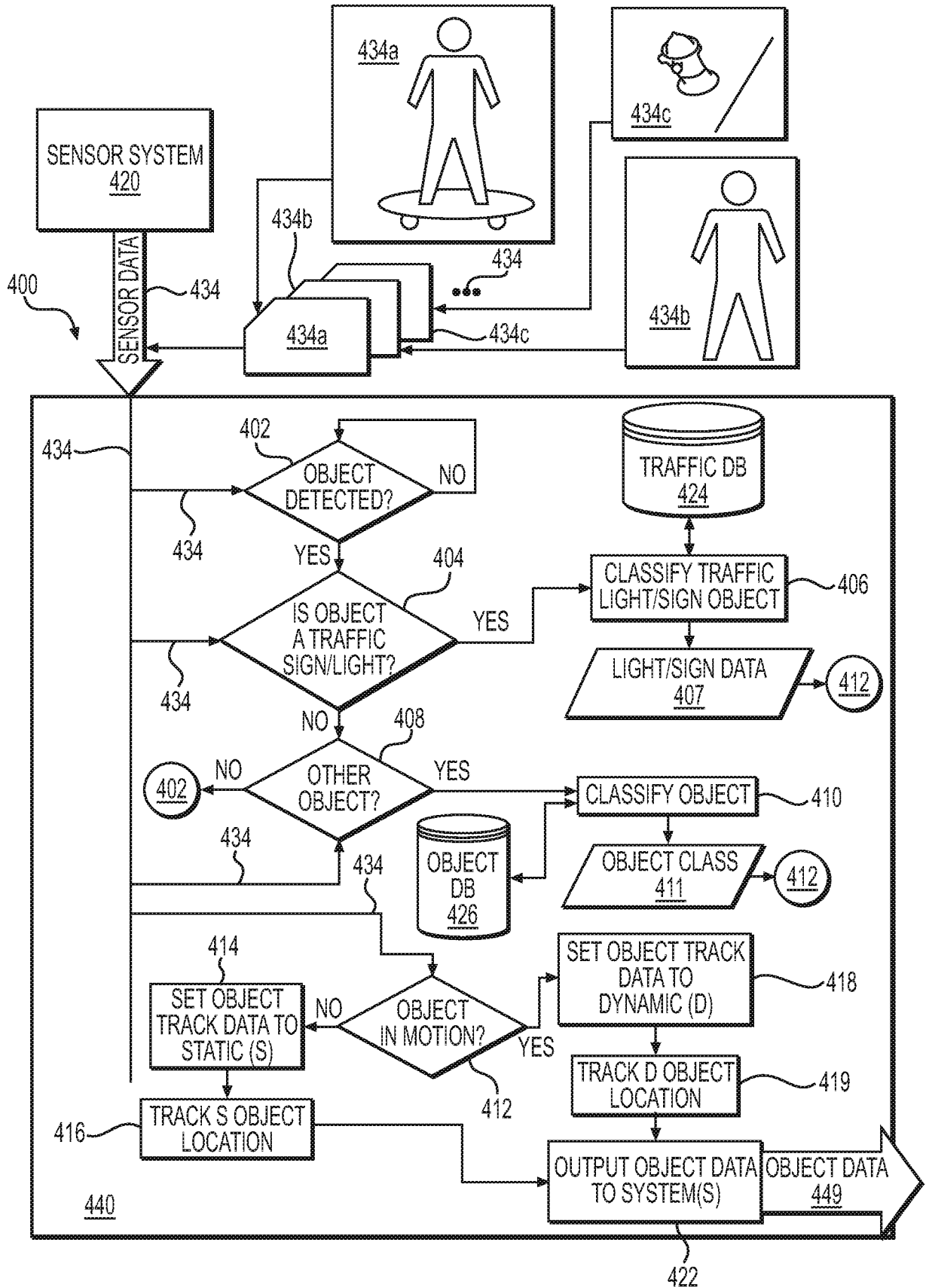

FIG. 4

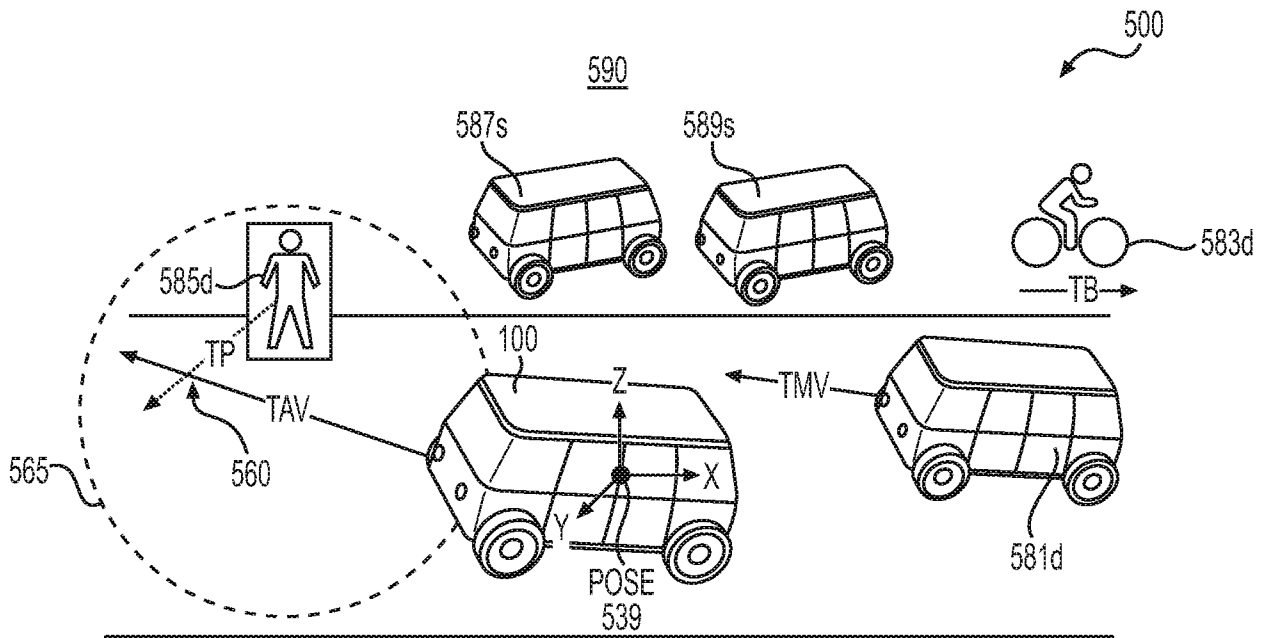

FIG. 5

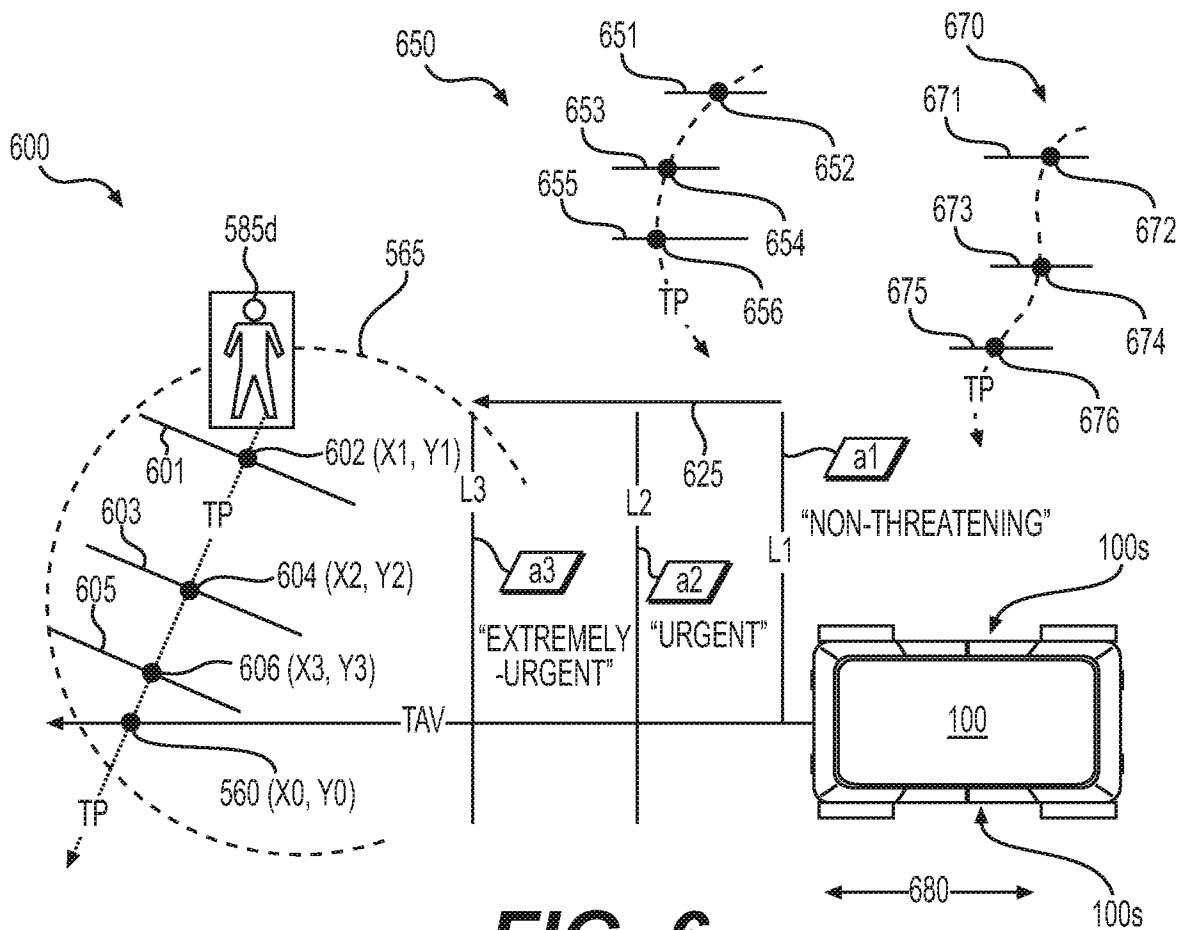

FIG. 6

9/37

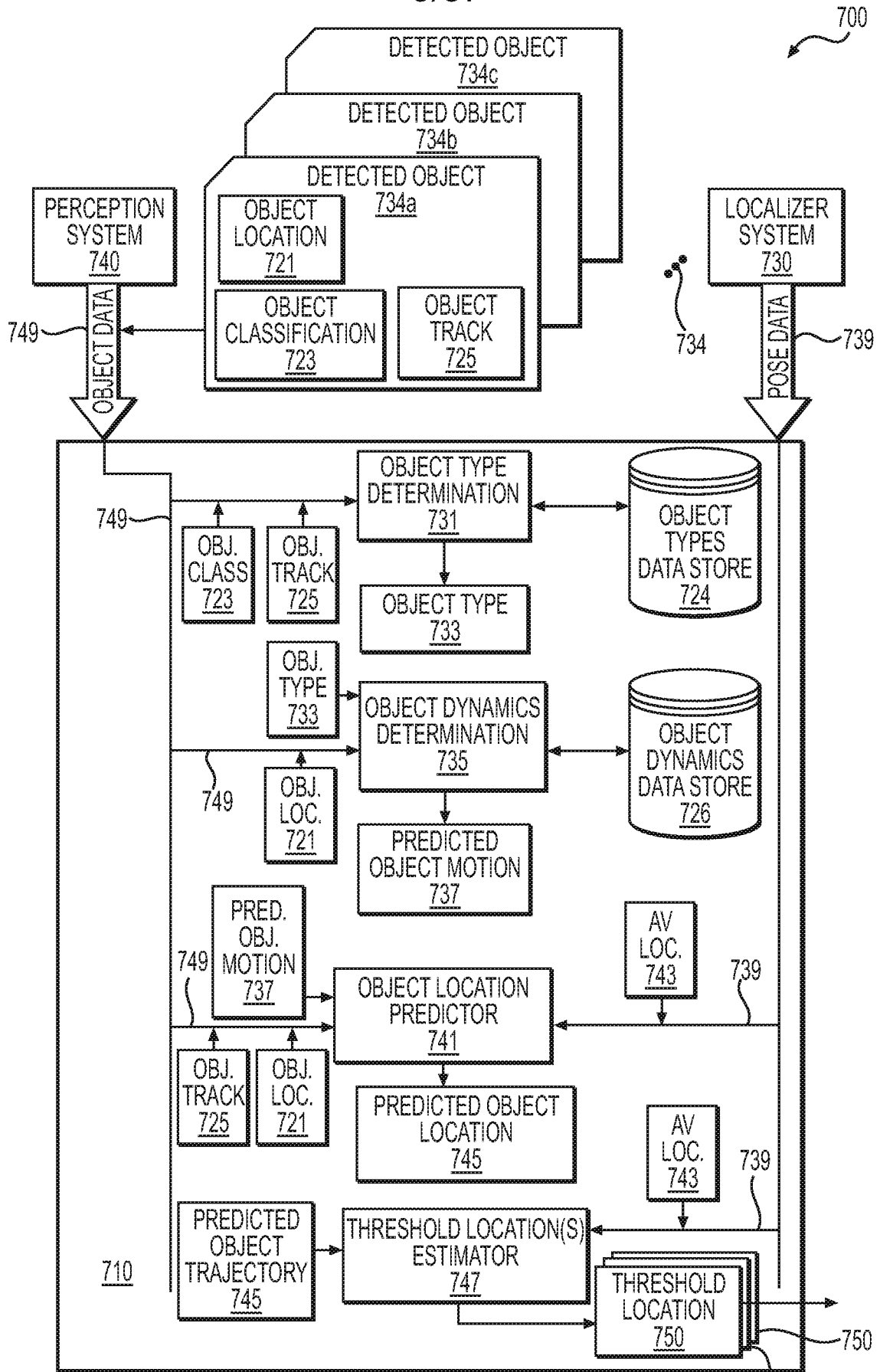

FIG. 7

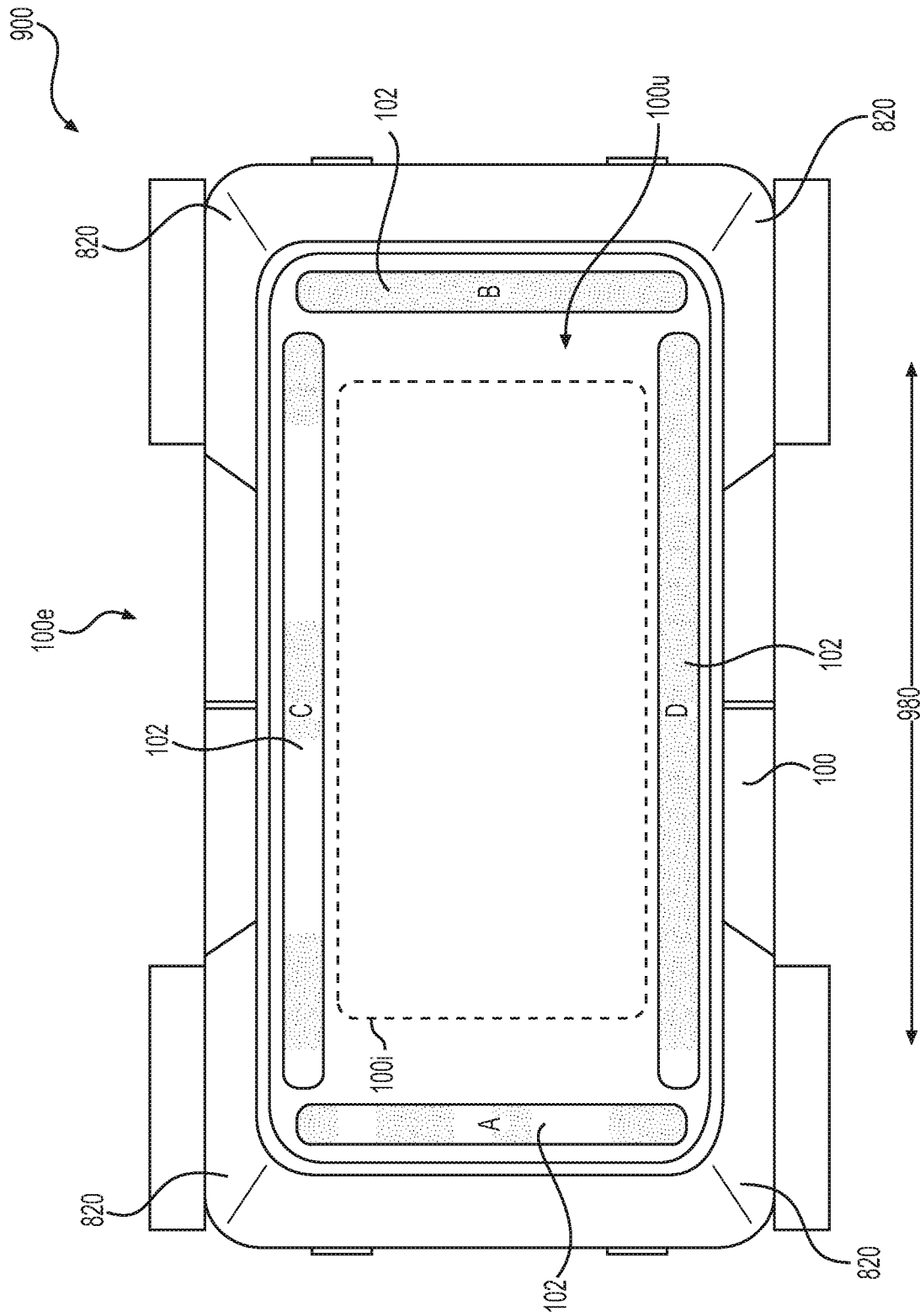

FIG. 9

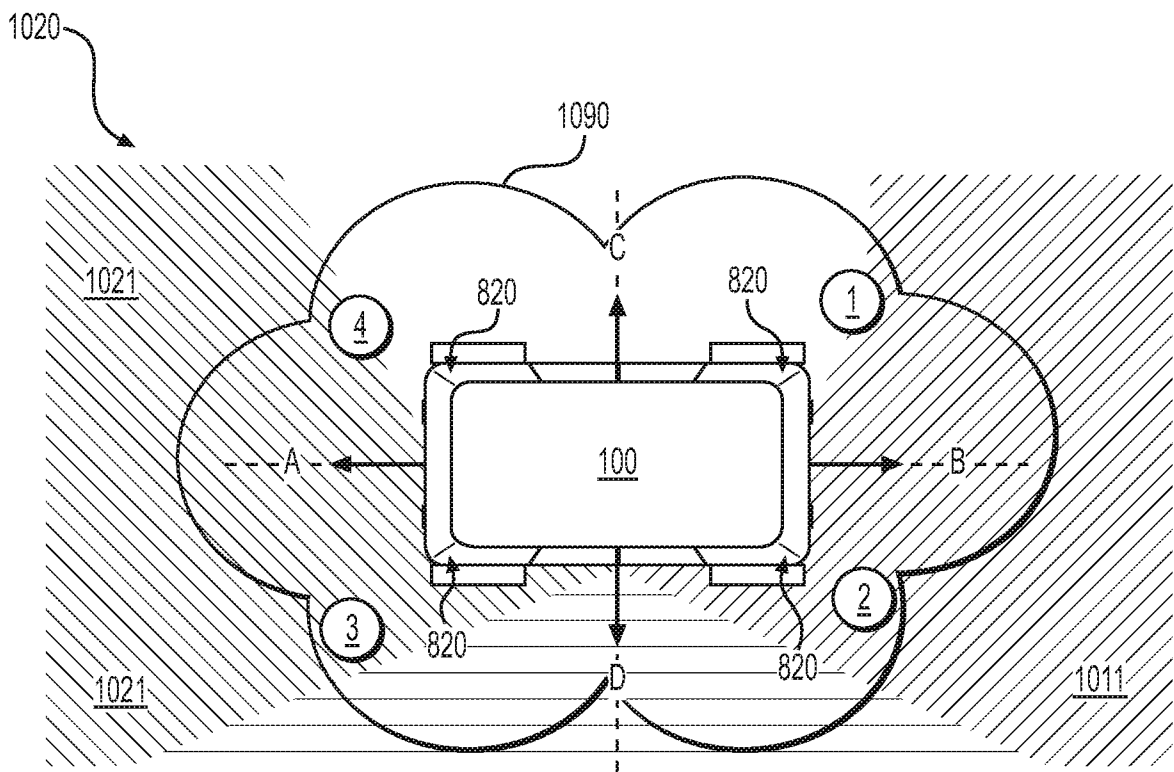
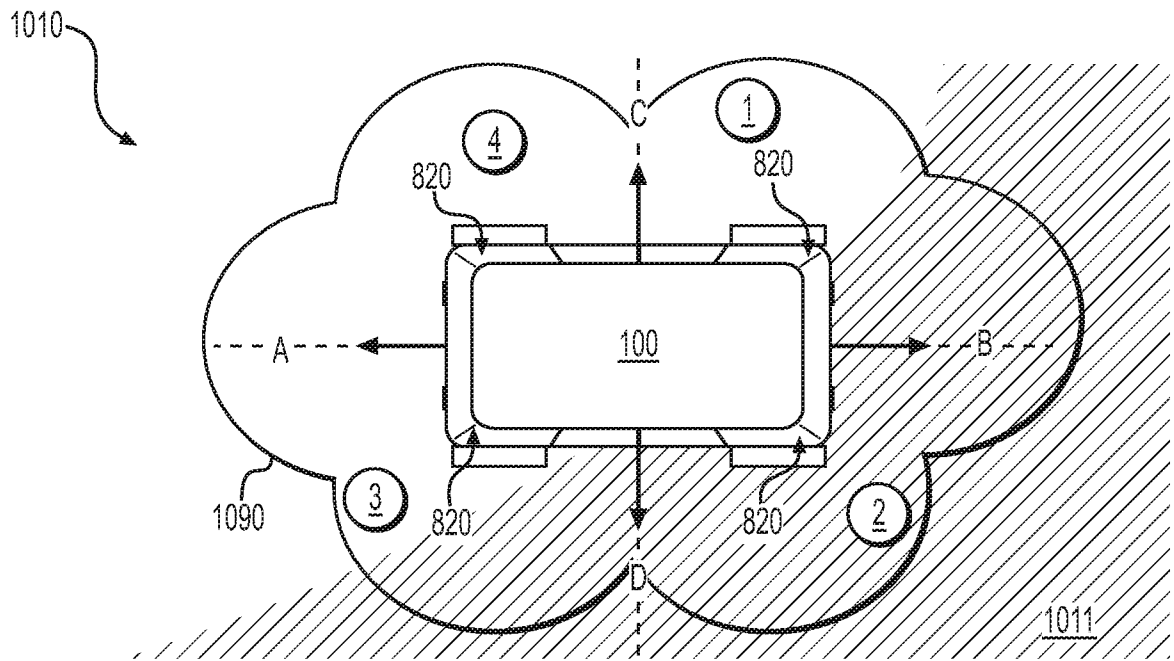

FIG. 10A

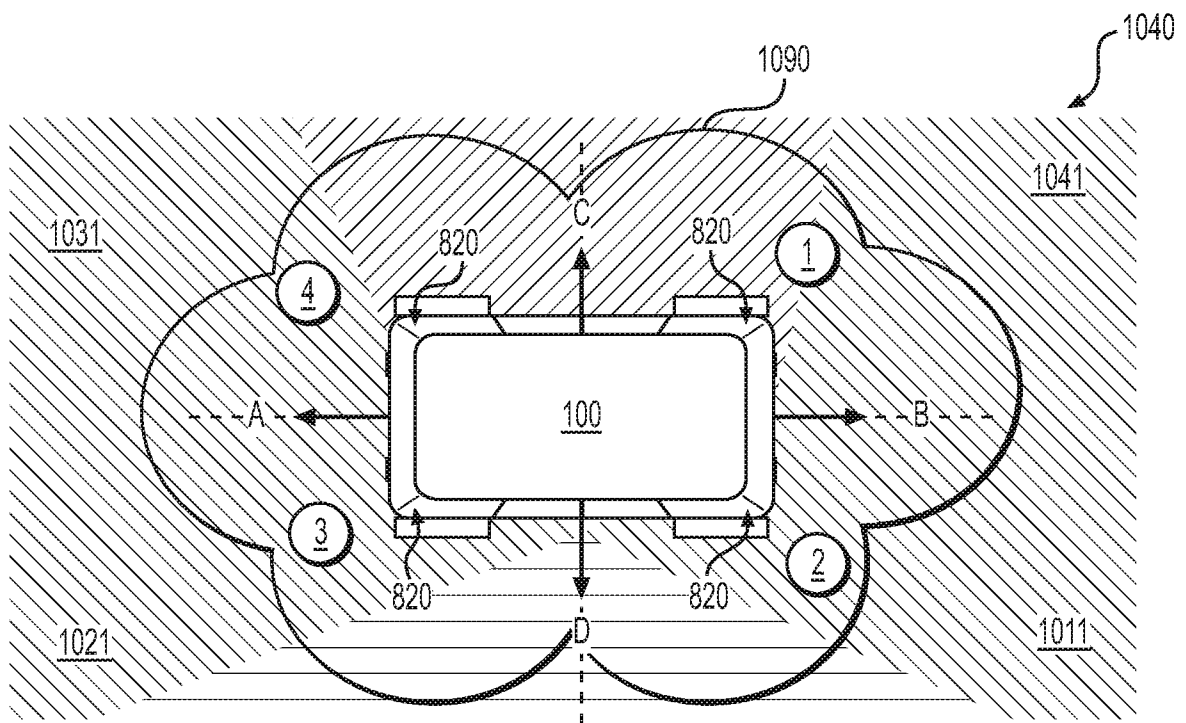
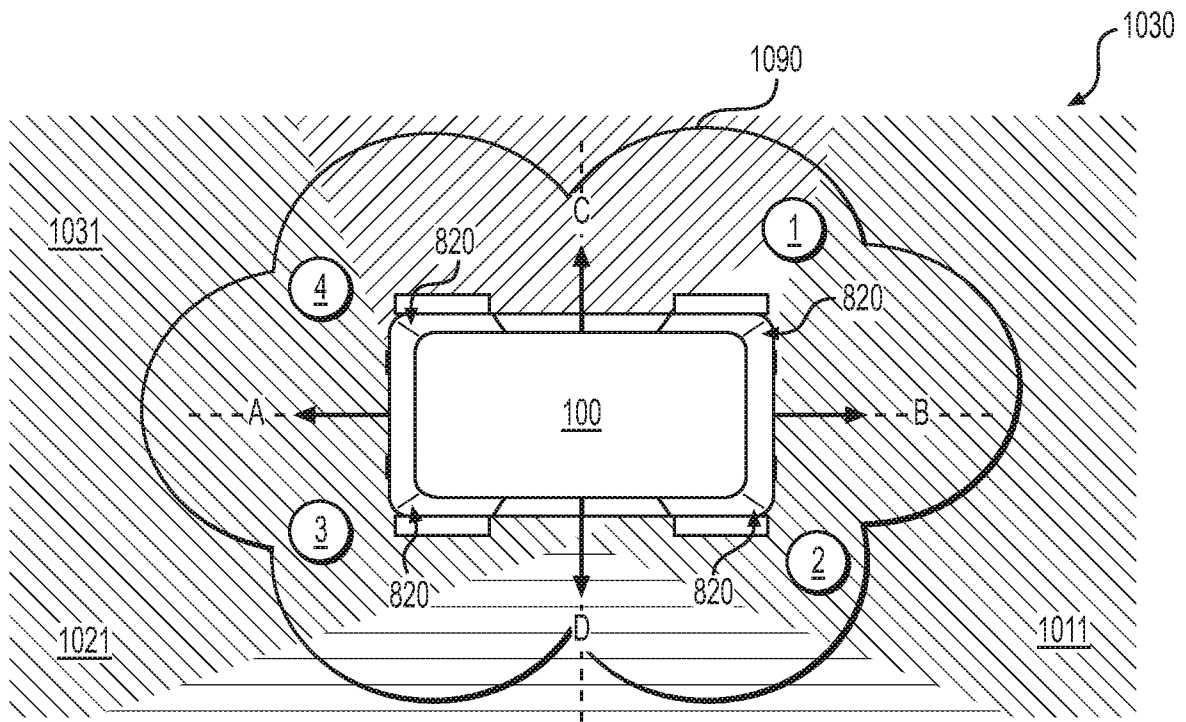

FIG. 10B

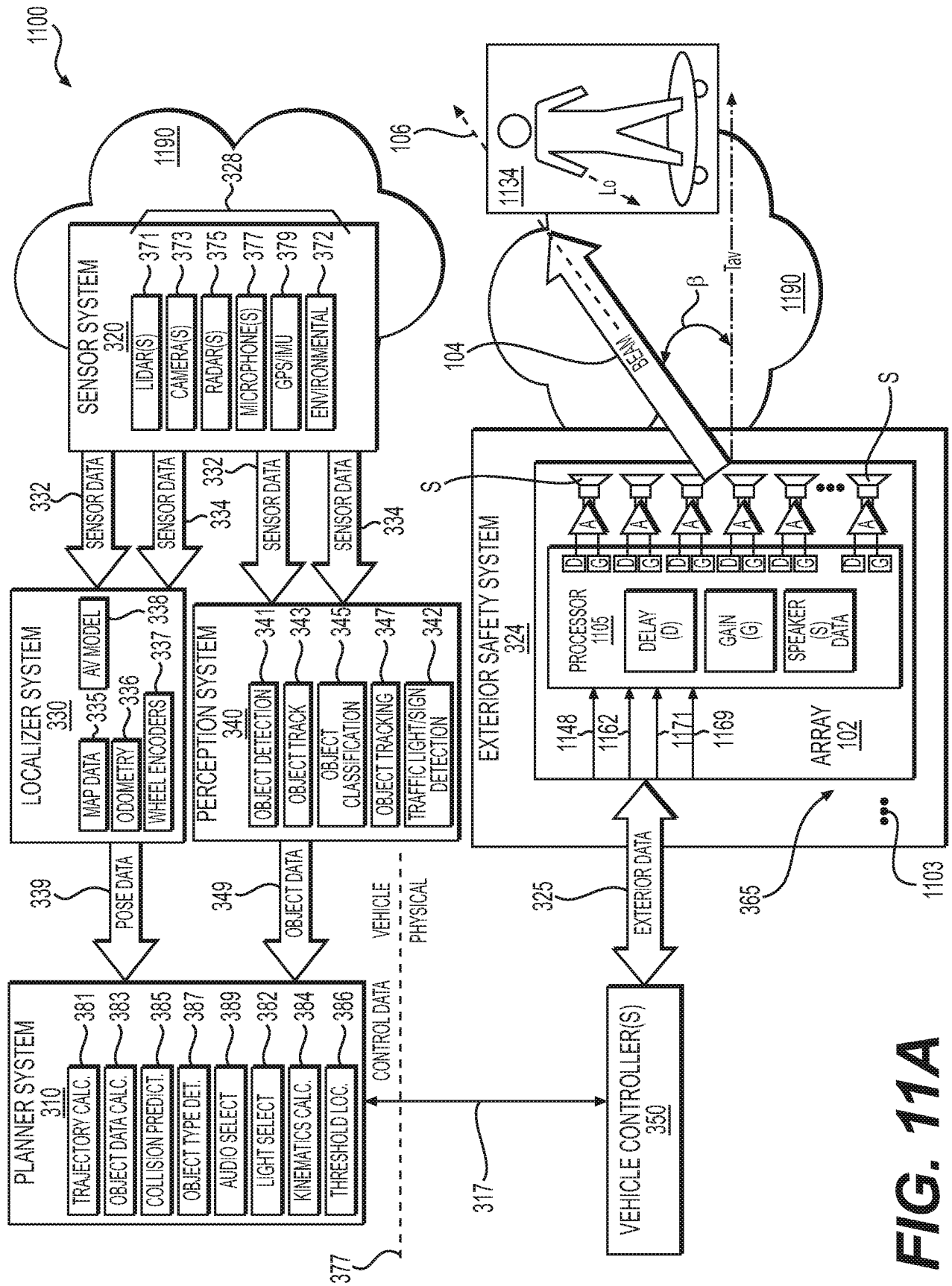
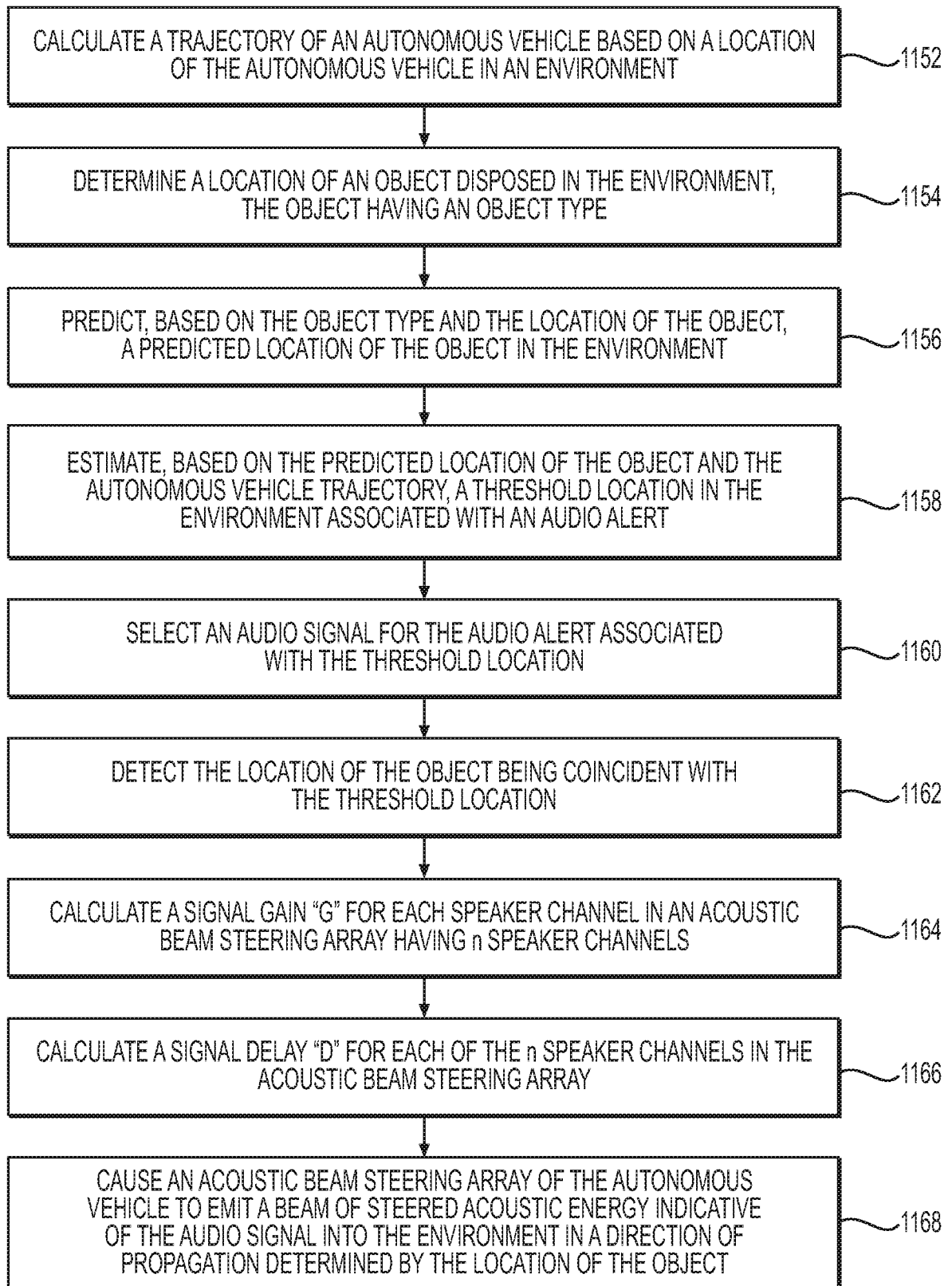

FIG. 11A

15/37

1150

**FIG. 11B**

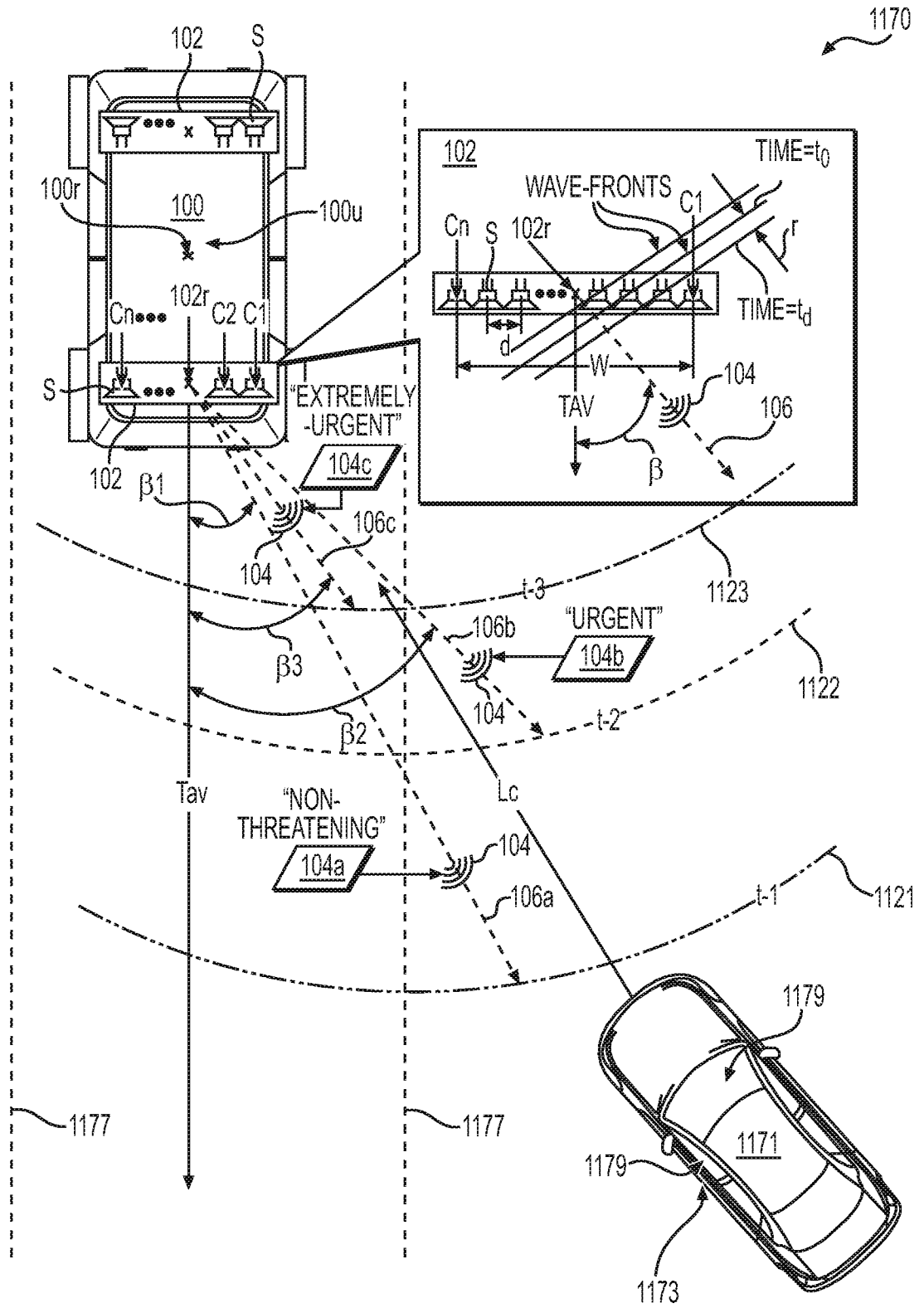

FIG. 11C

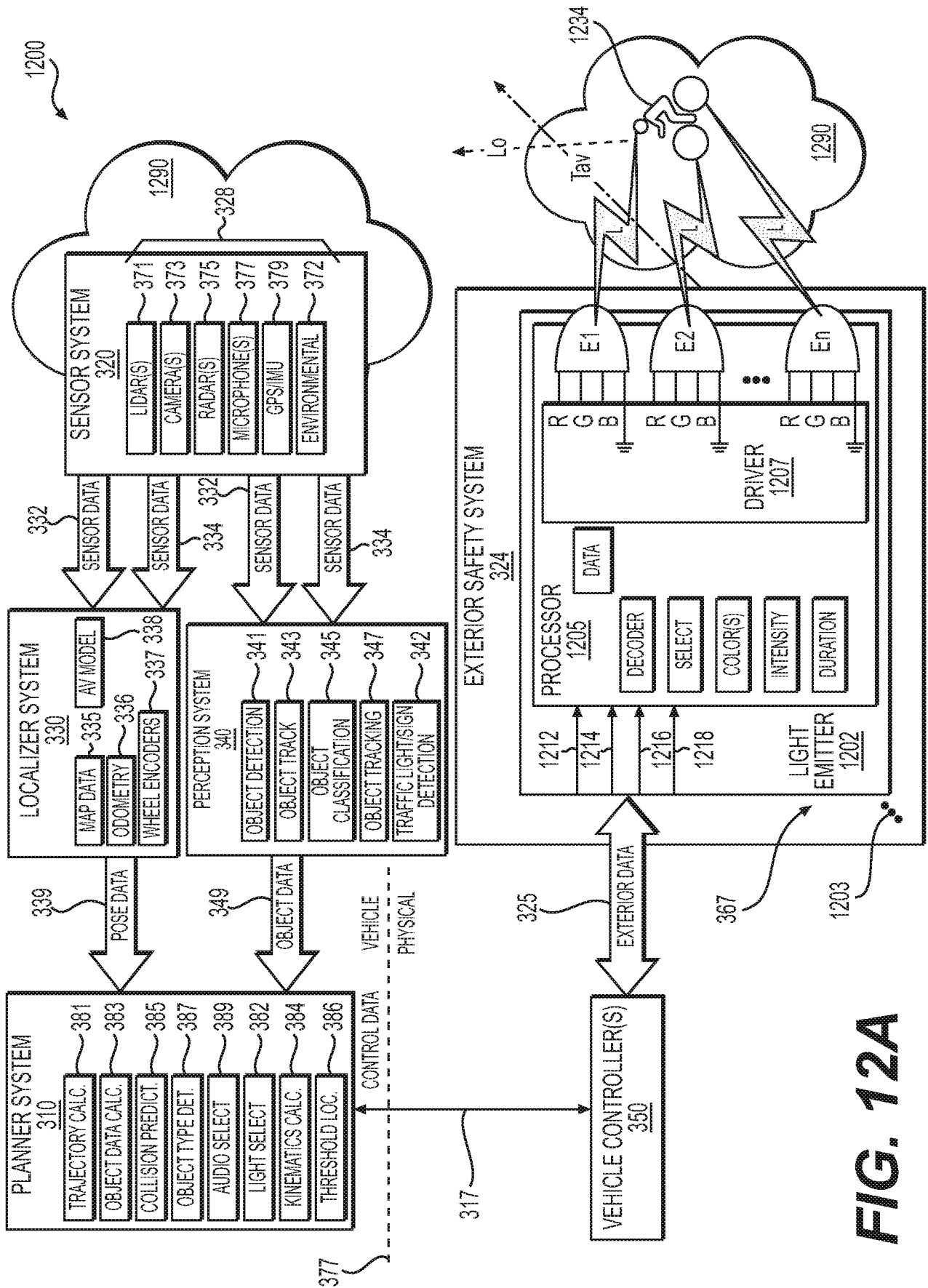

FIG. 12A

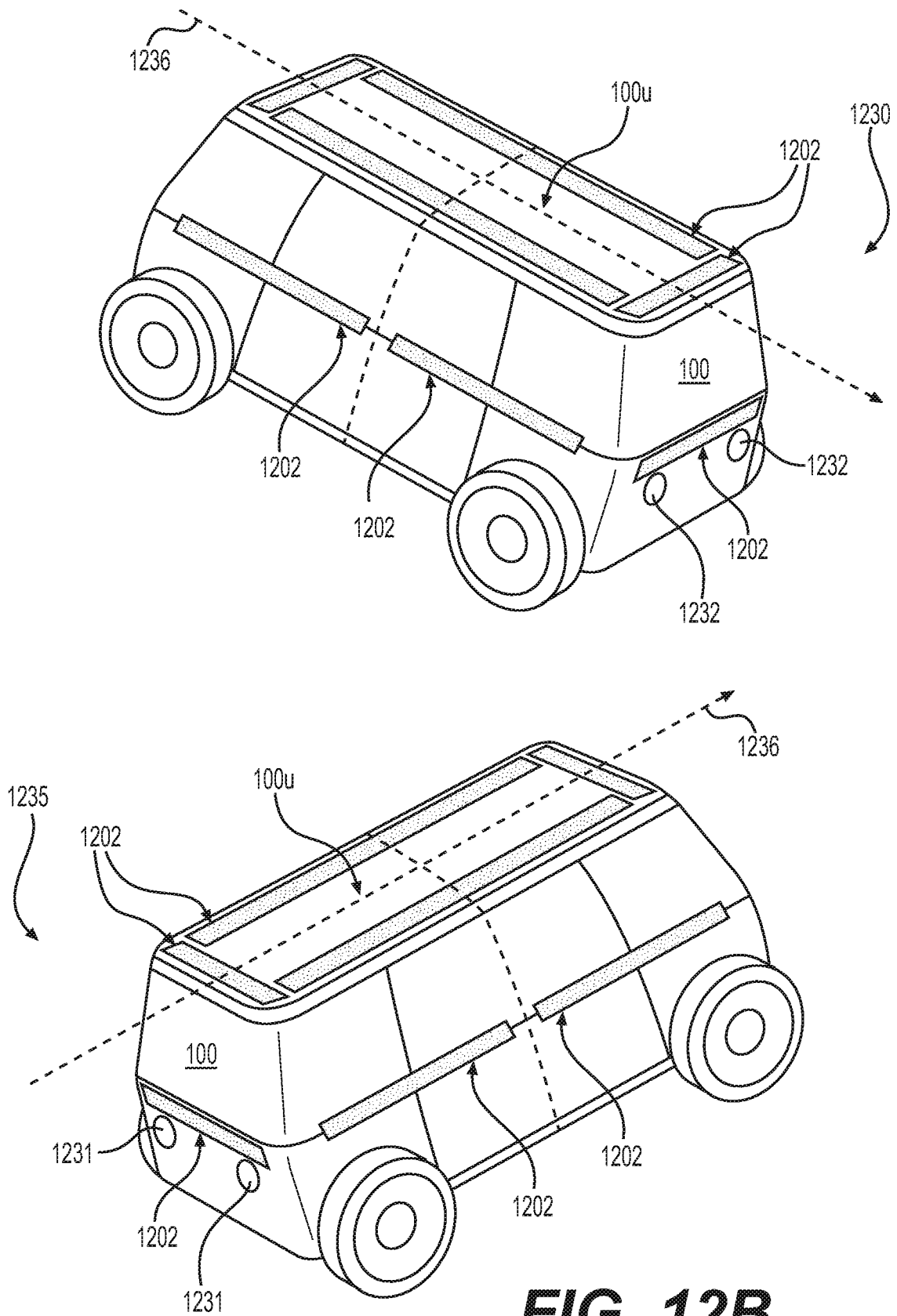

FIG. 12B

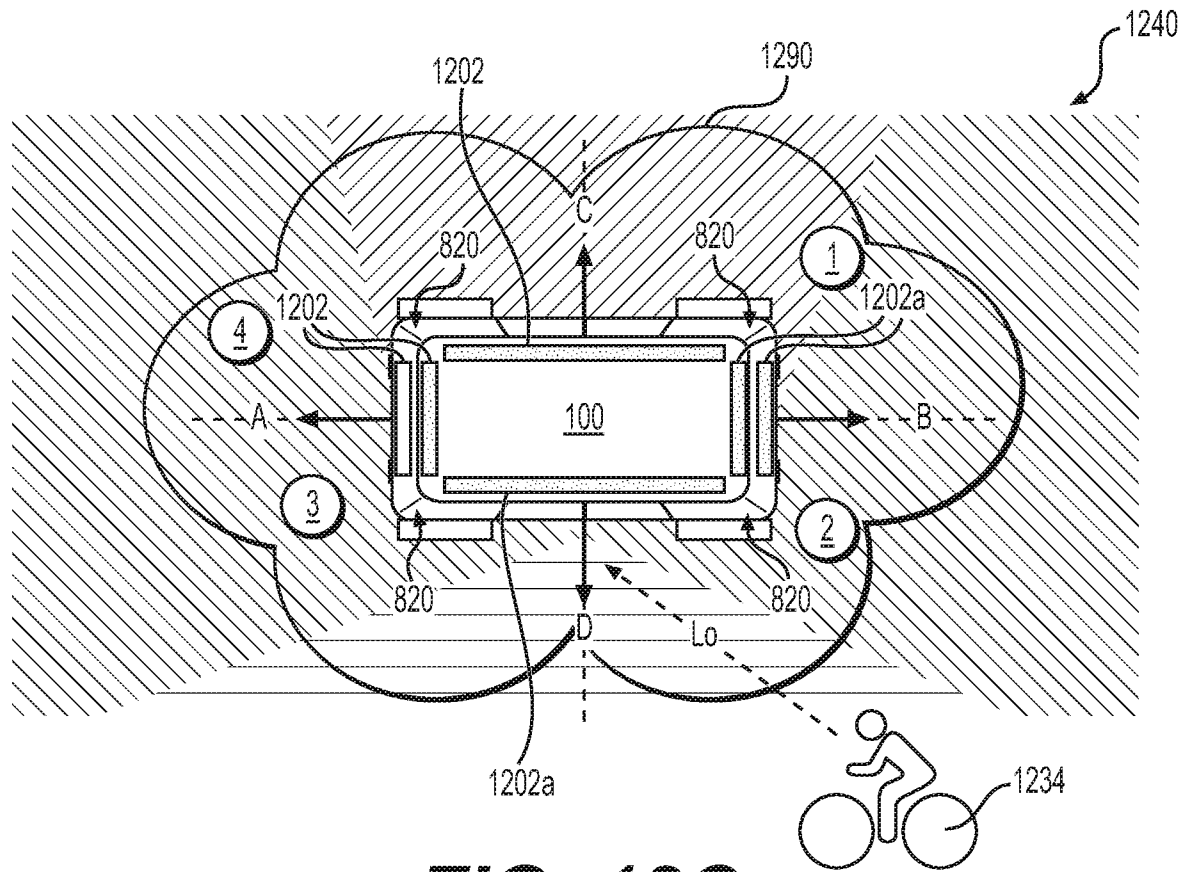

FIG. 12C

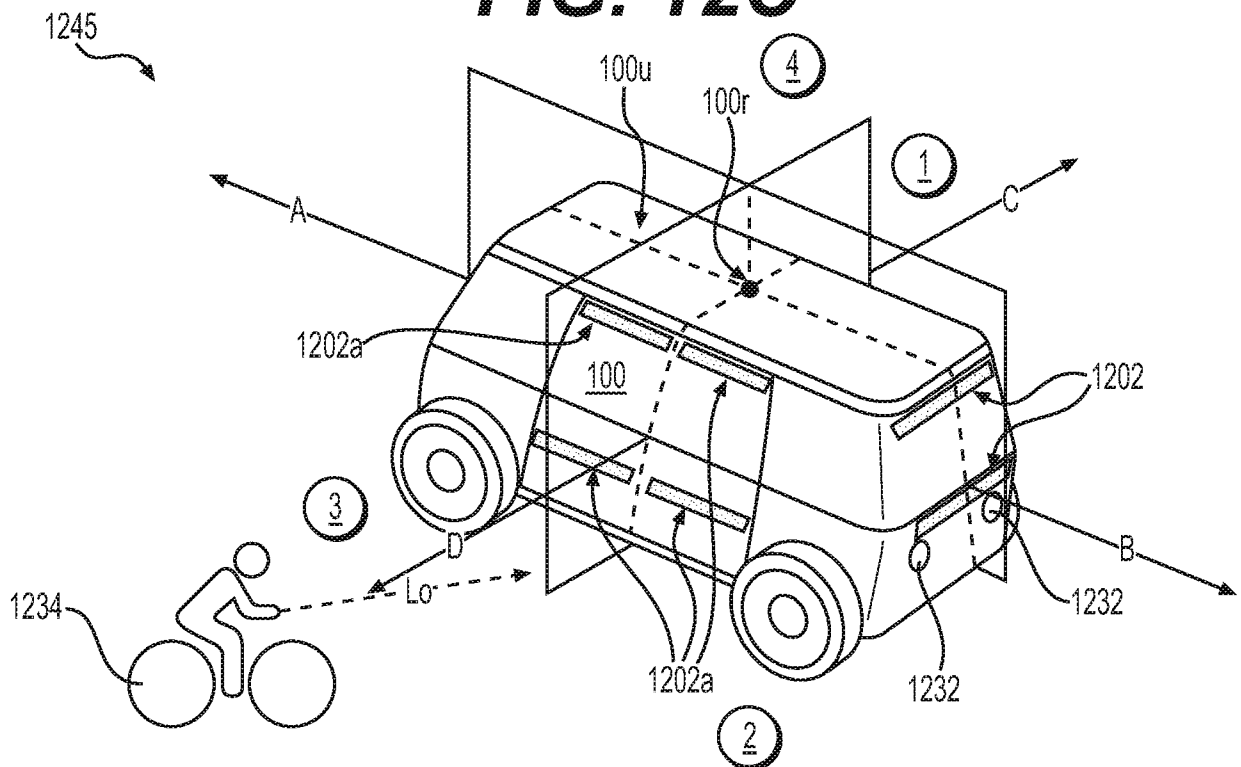

FIG. 12D

1250

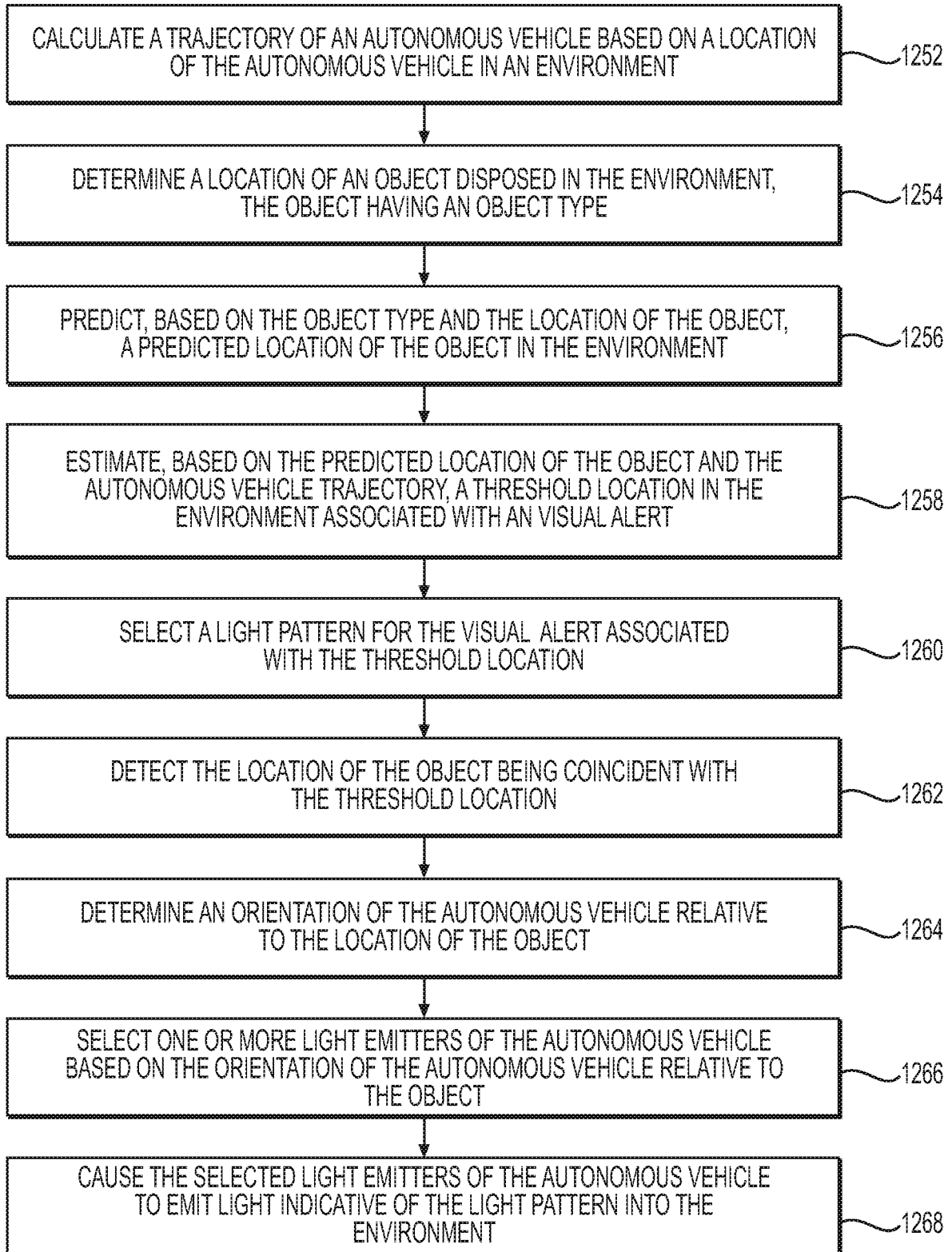

FIG. 12E

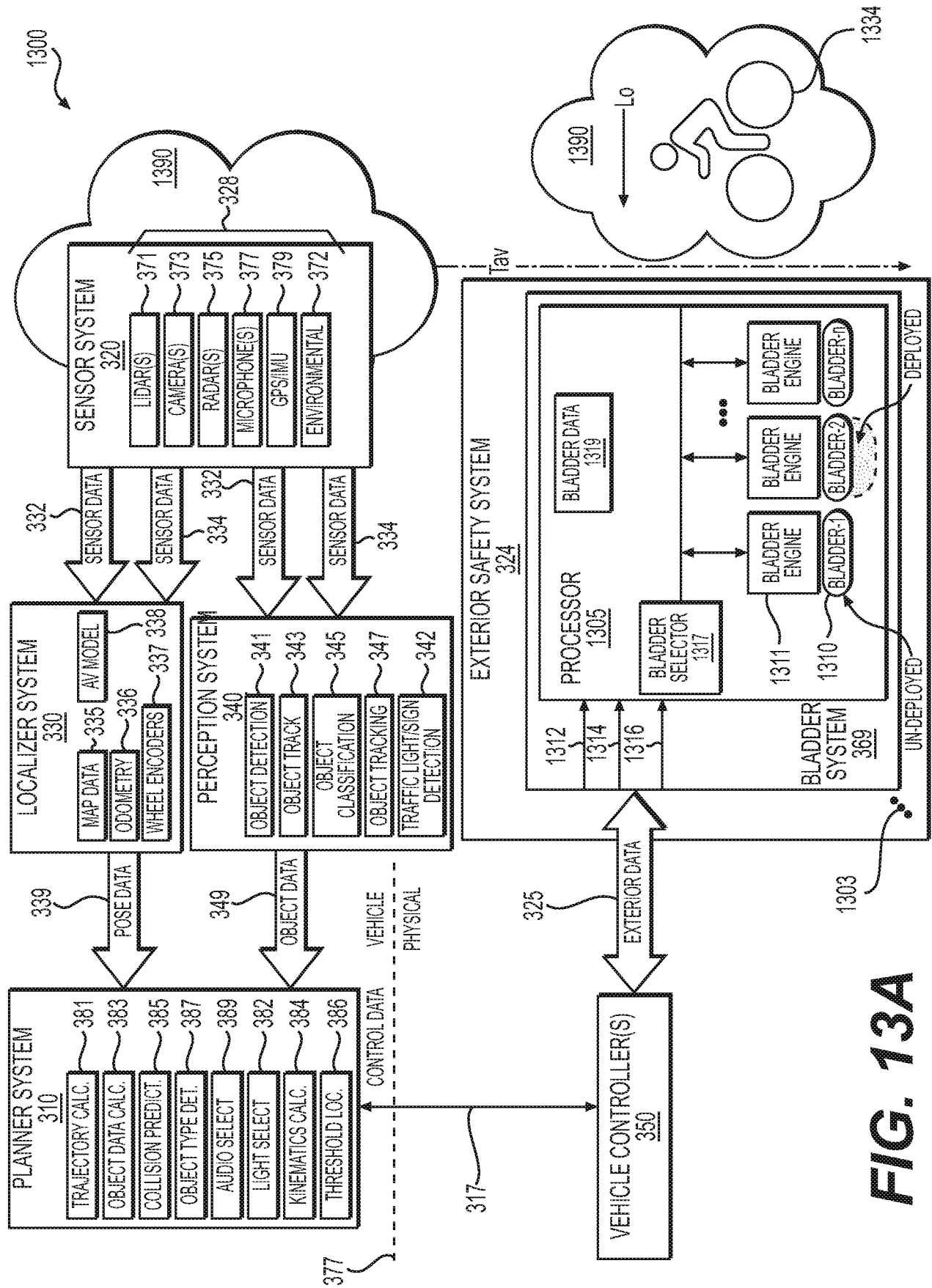

FIG. 13A

23/37

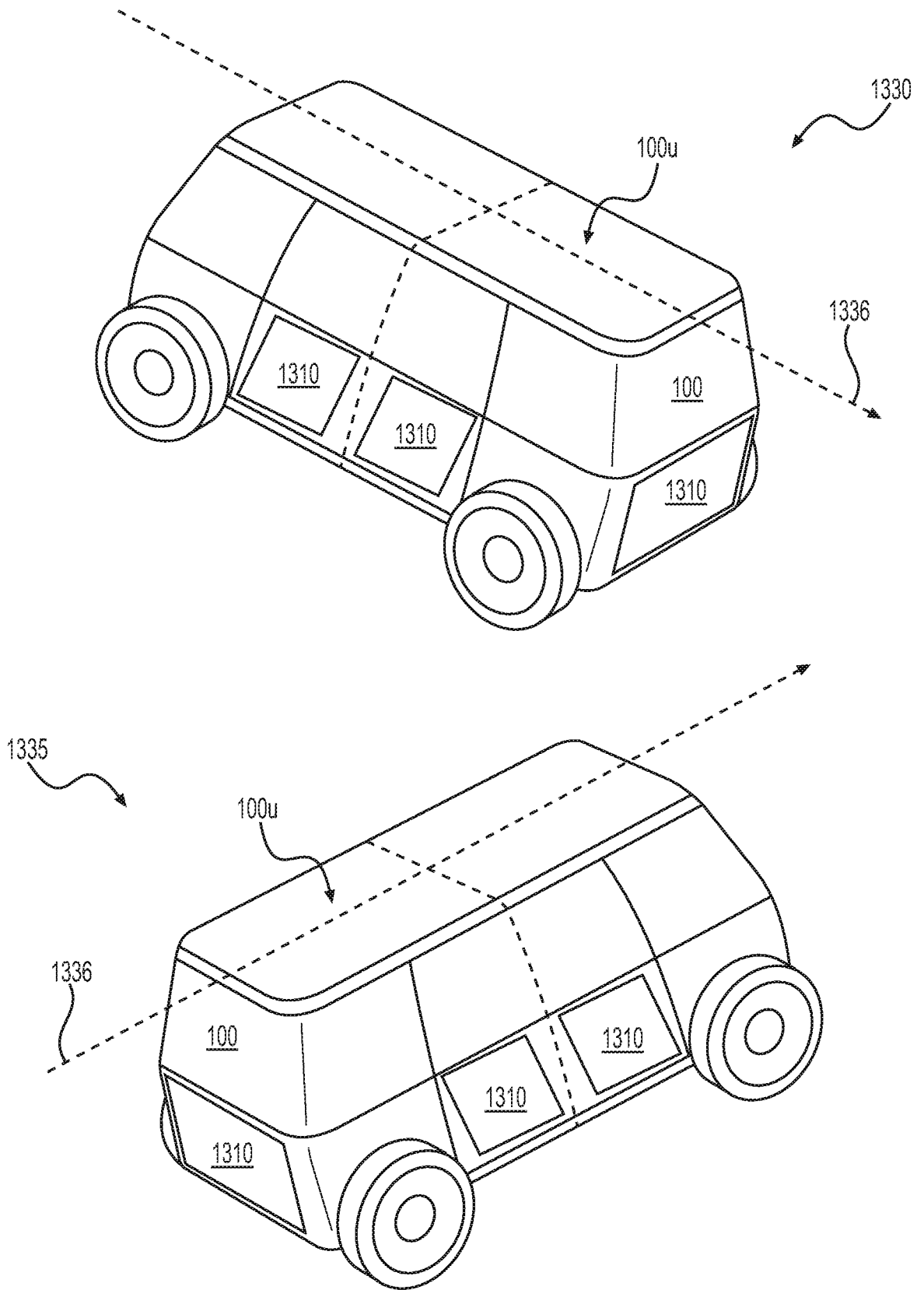

FIG. 13B

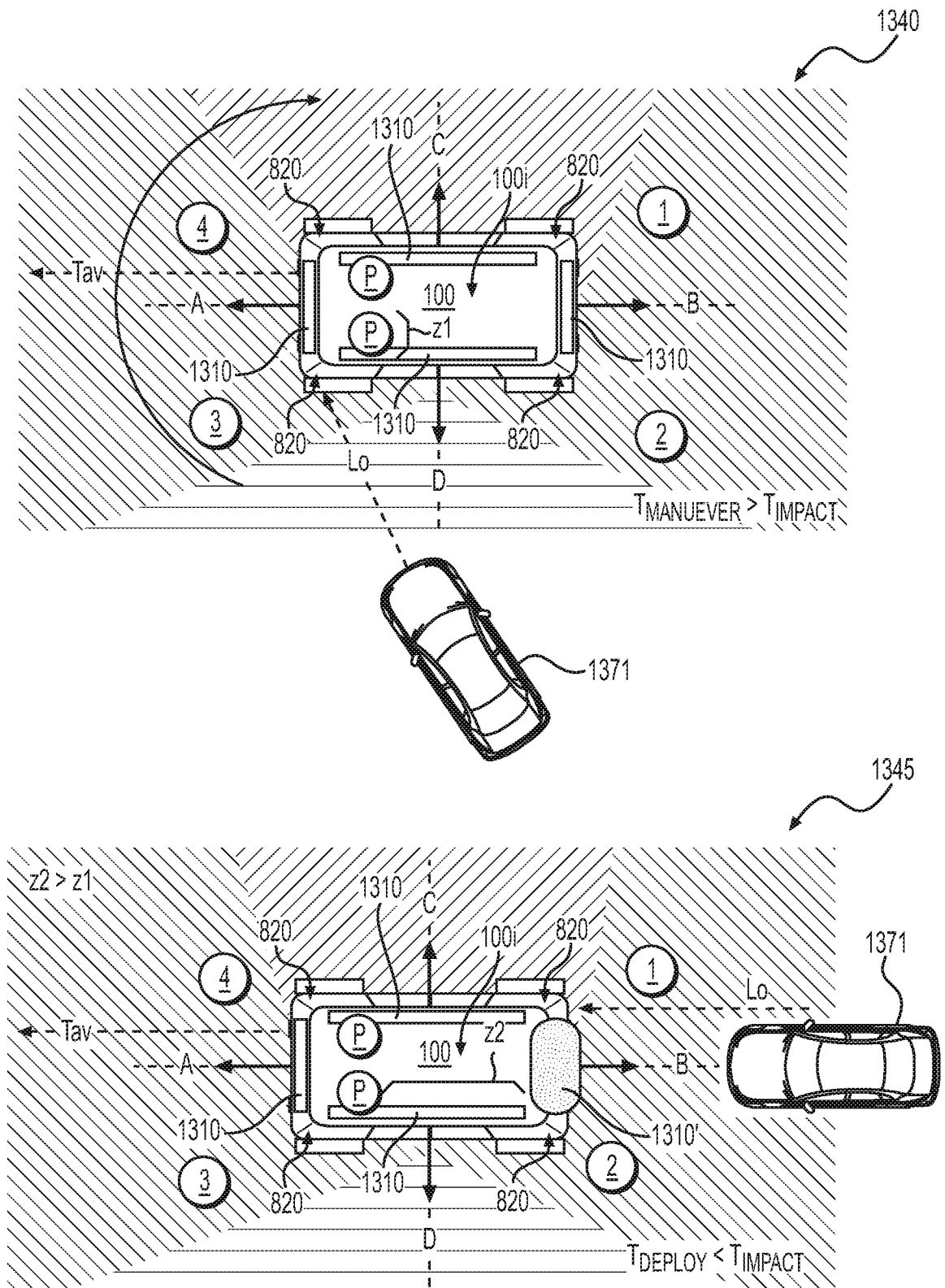

FIG. 13C

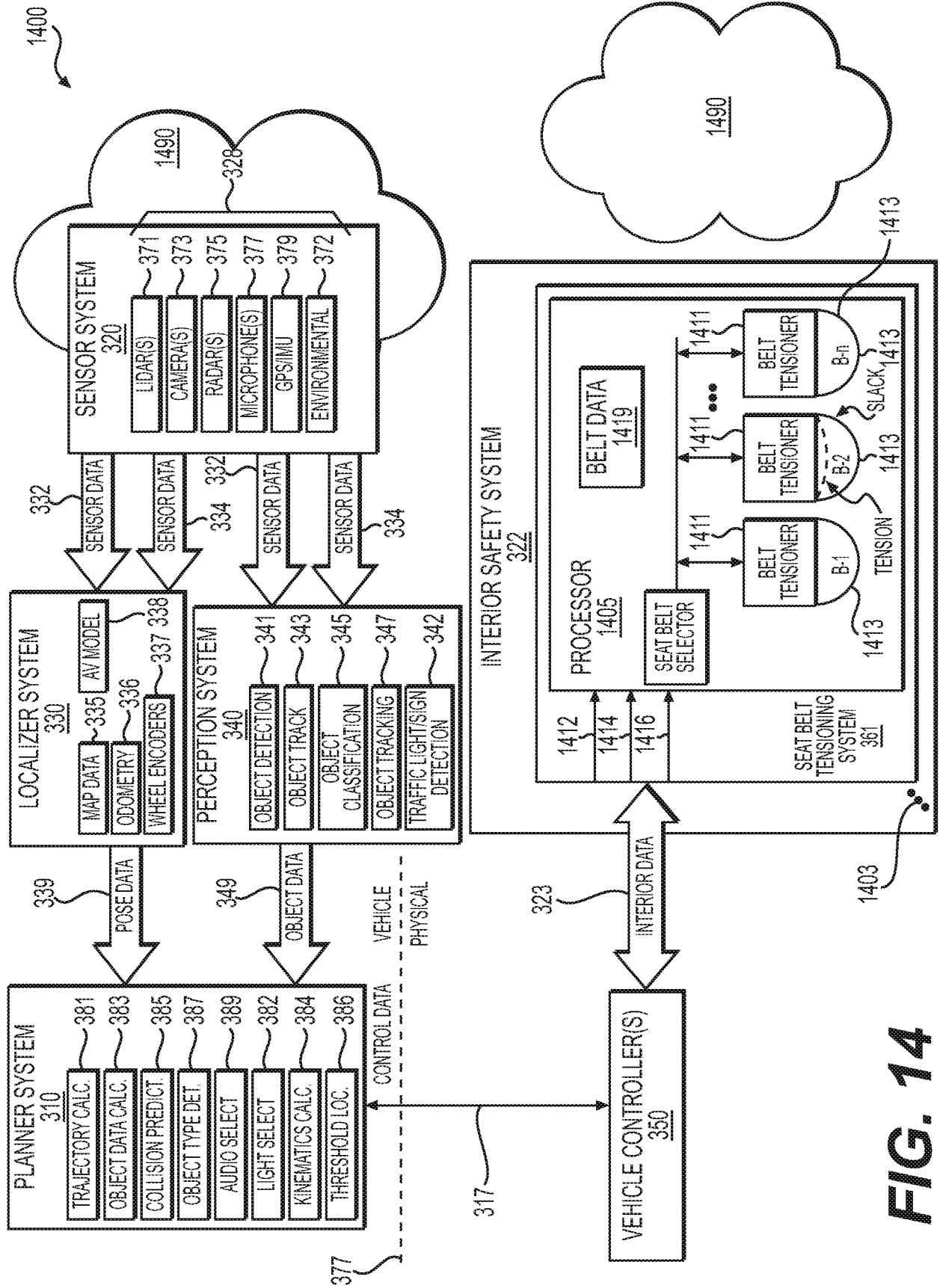

FIG. 14

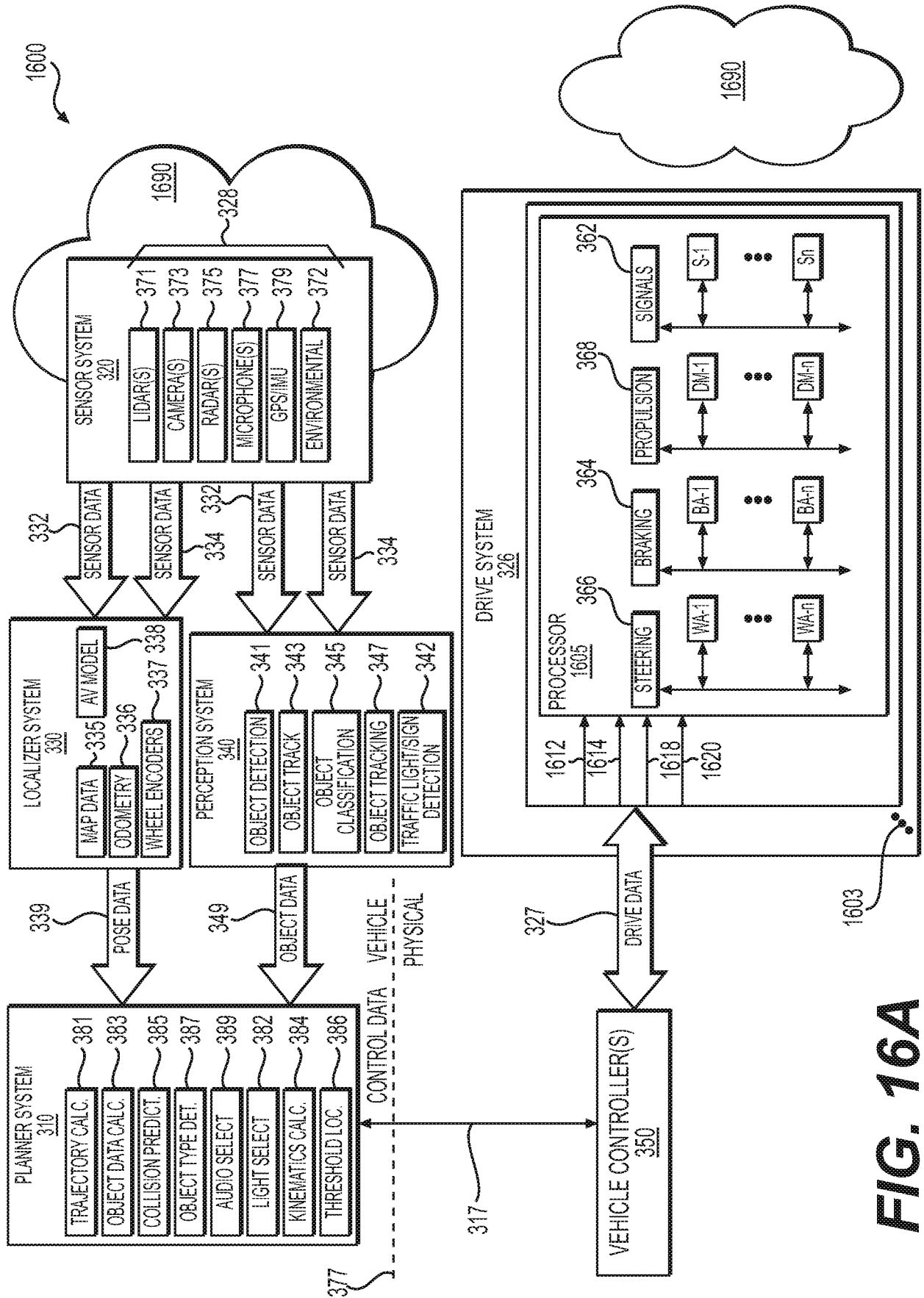
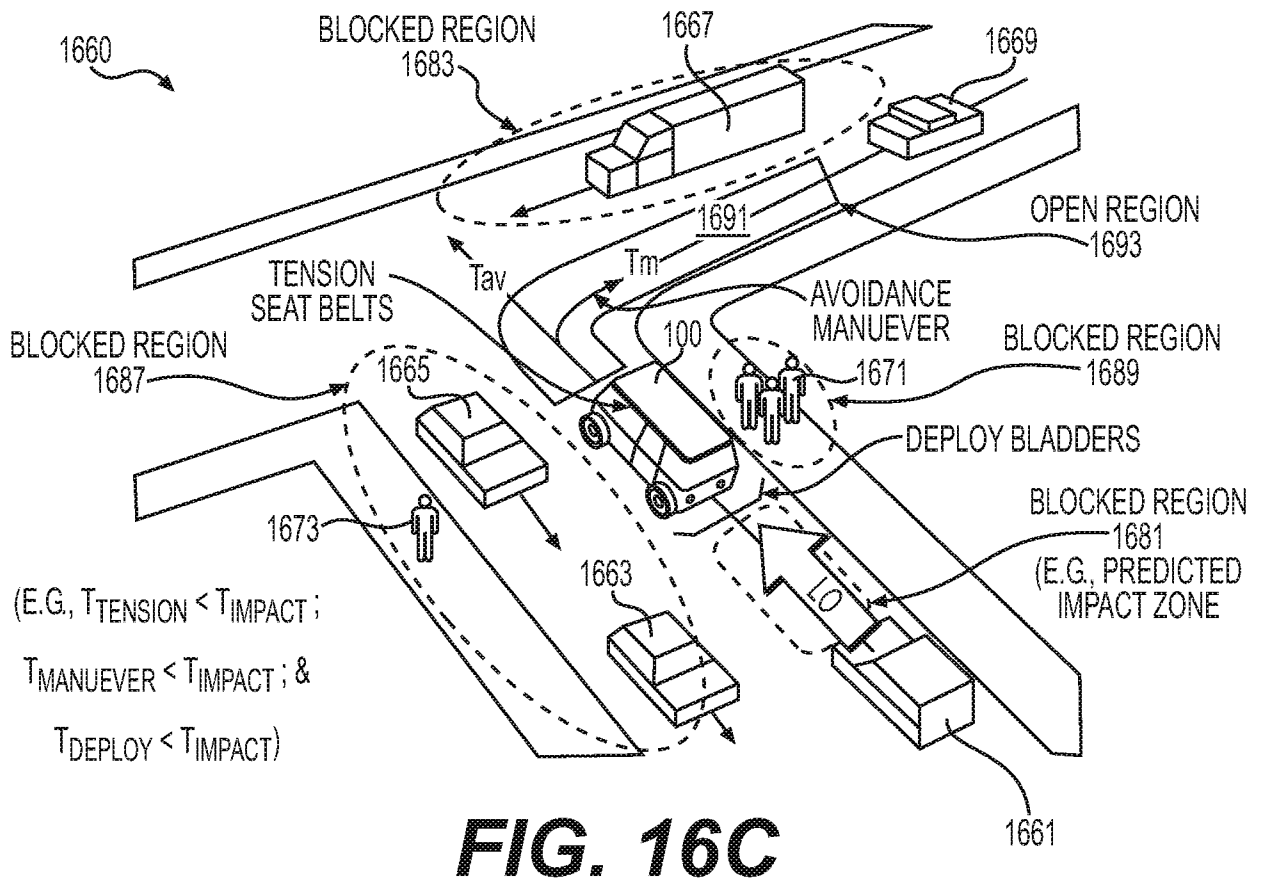
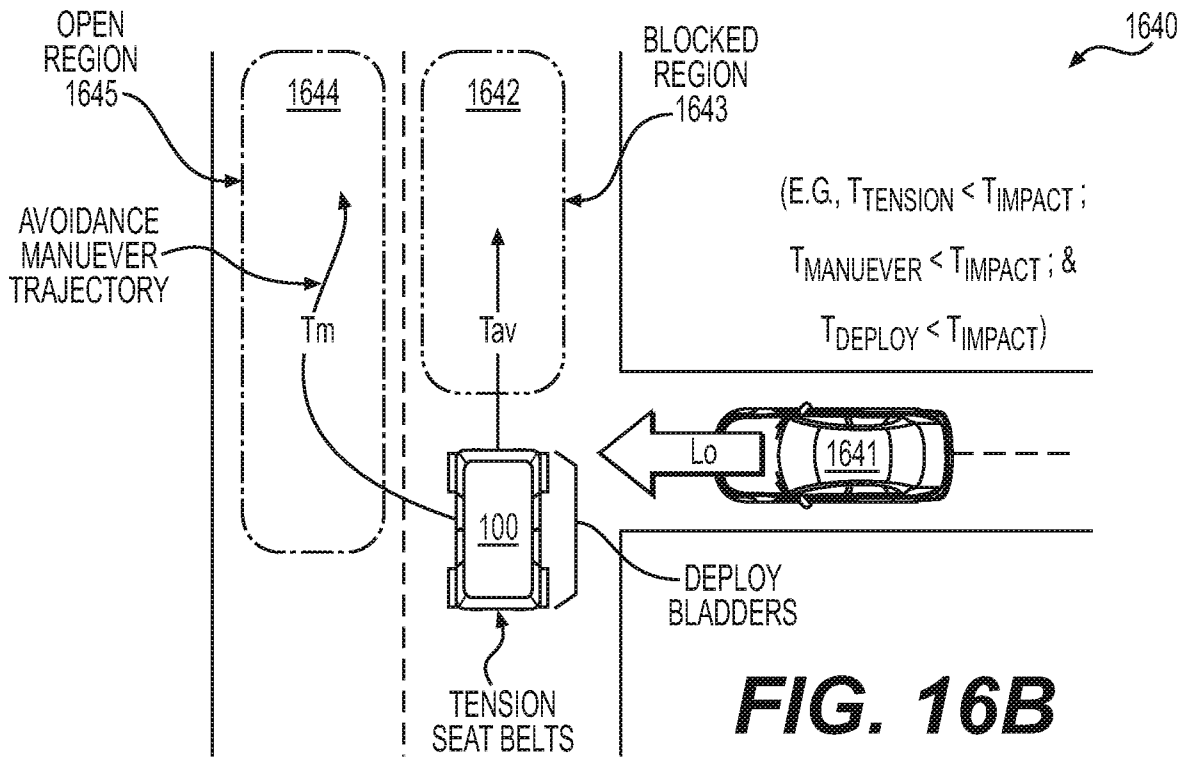

FIG. 16A



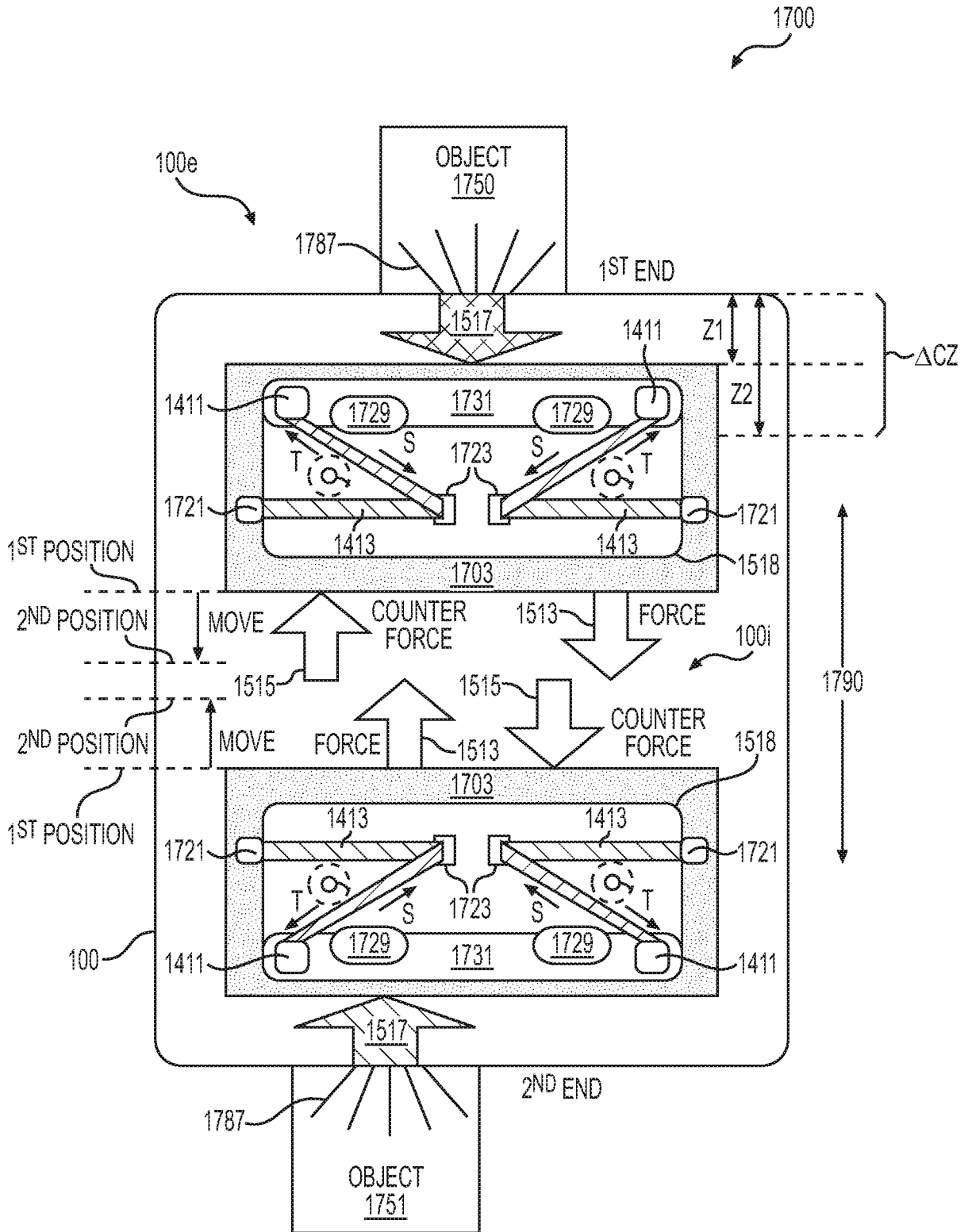

FIG. 17

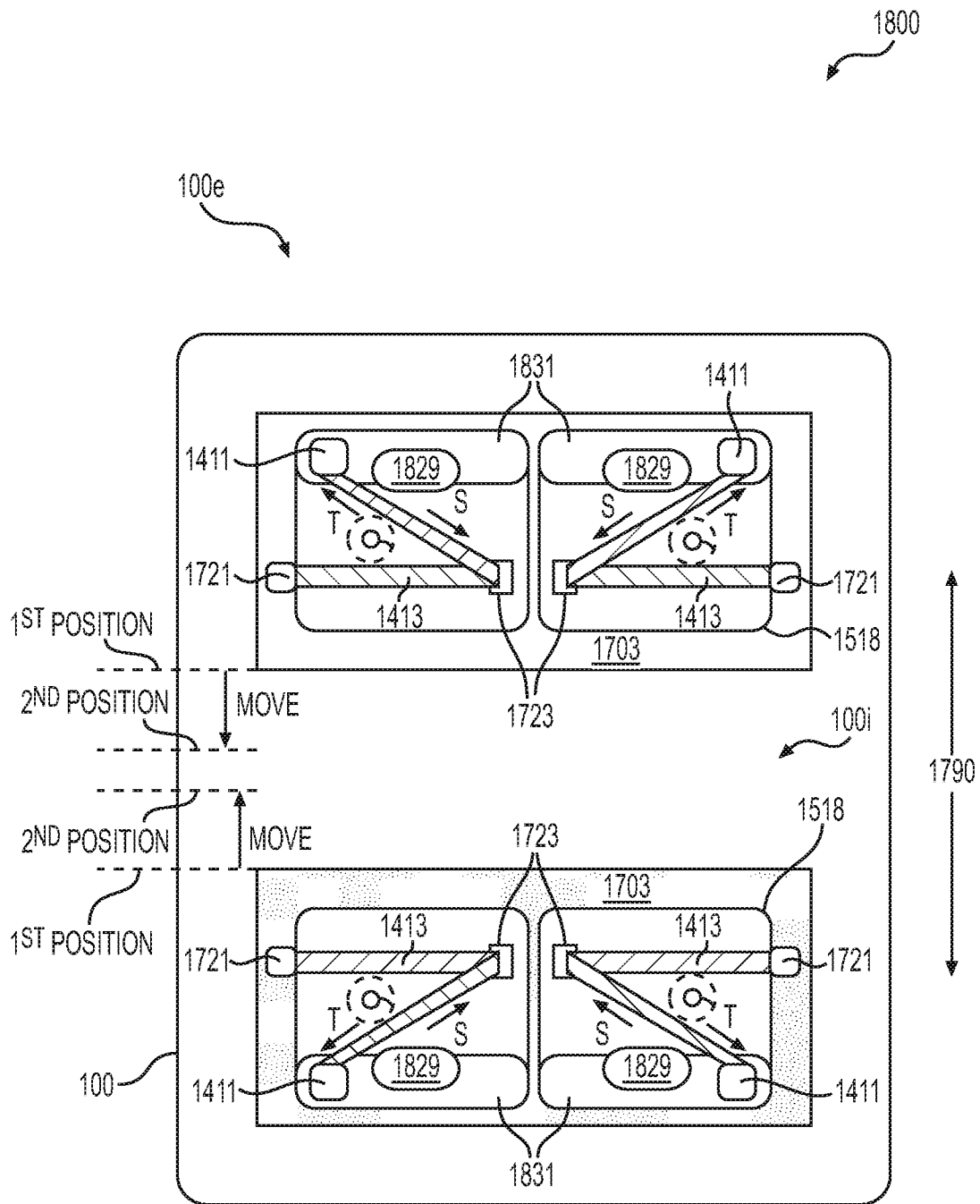

FIG. 18

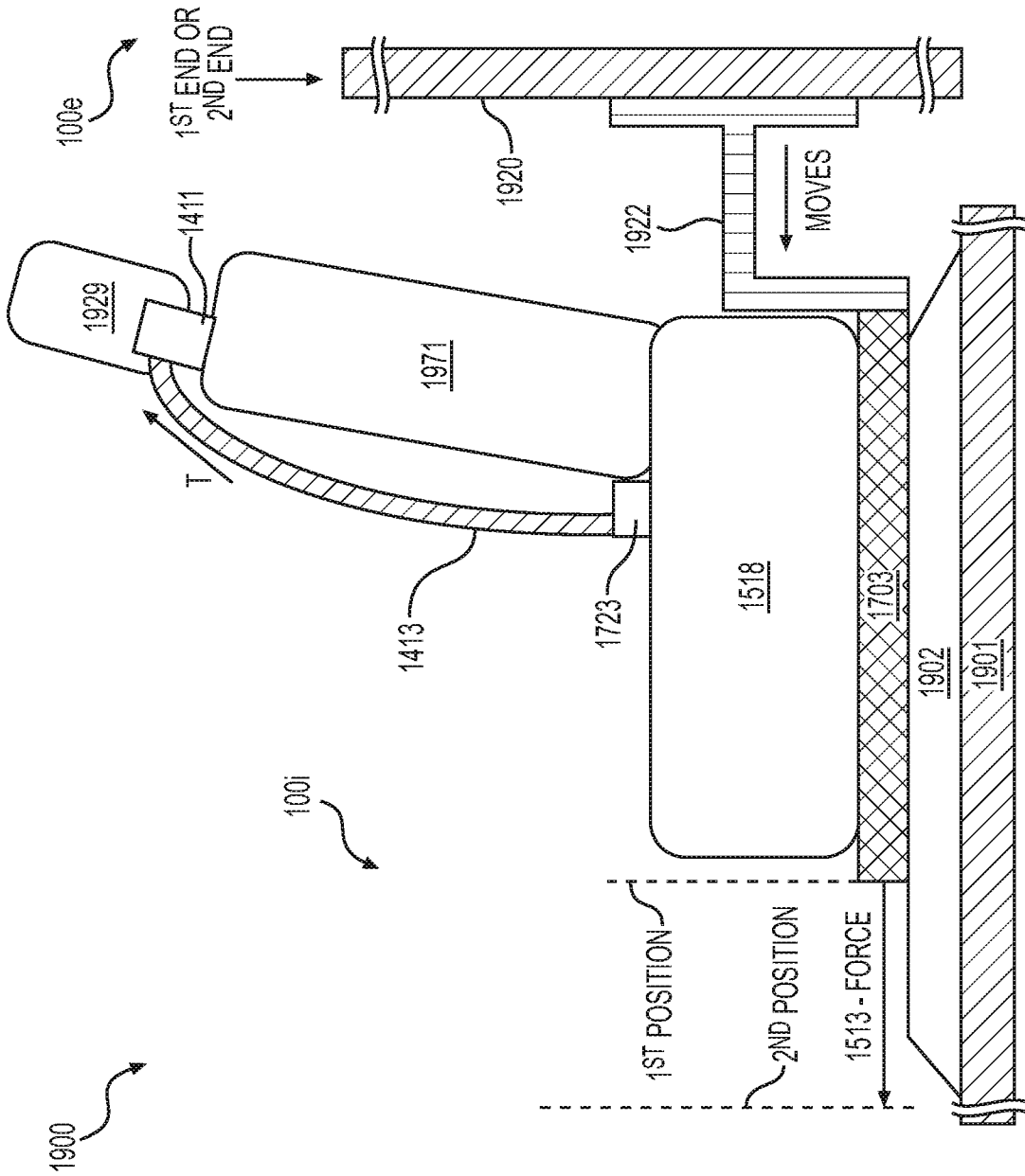

FIG. 19

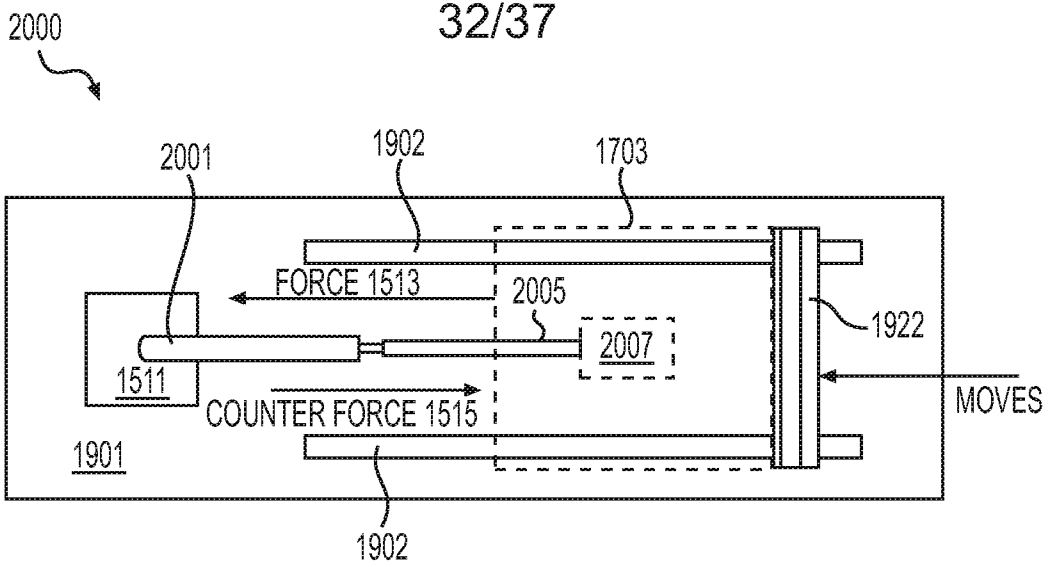

FIG. 20

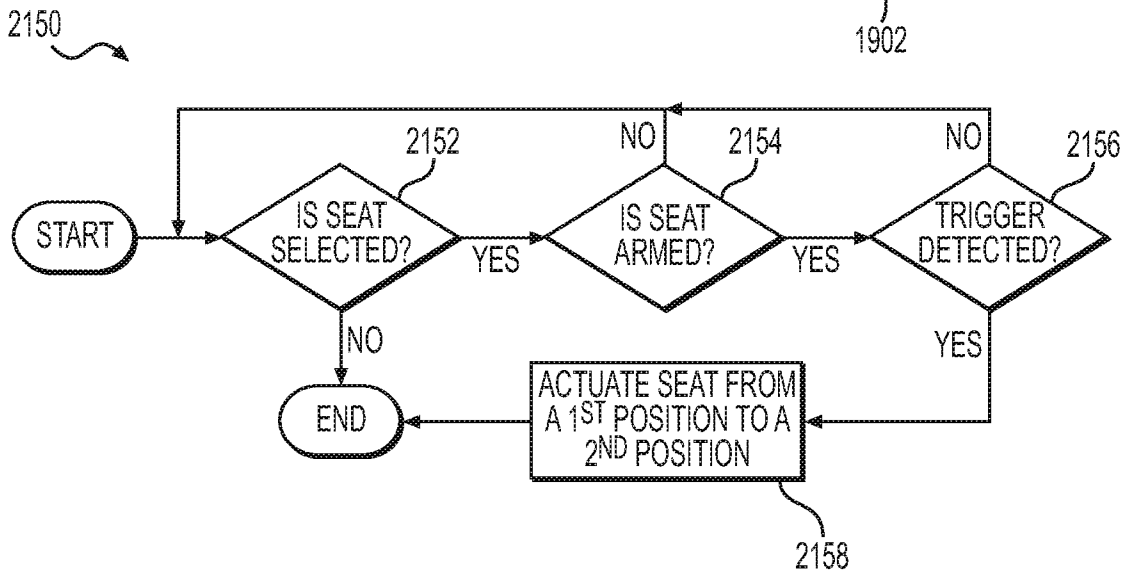
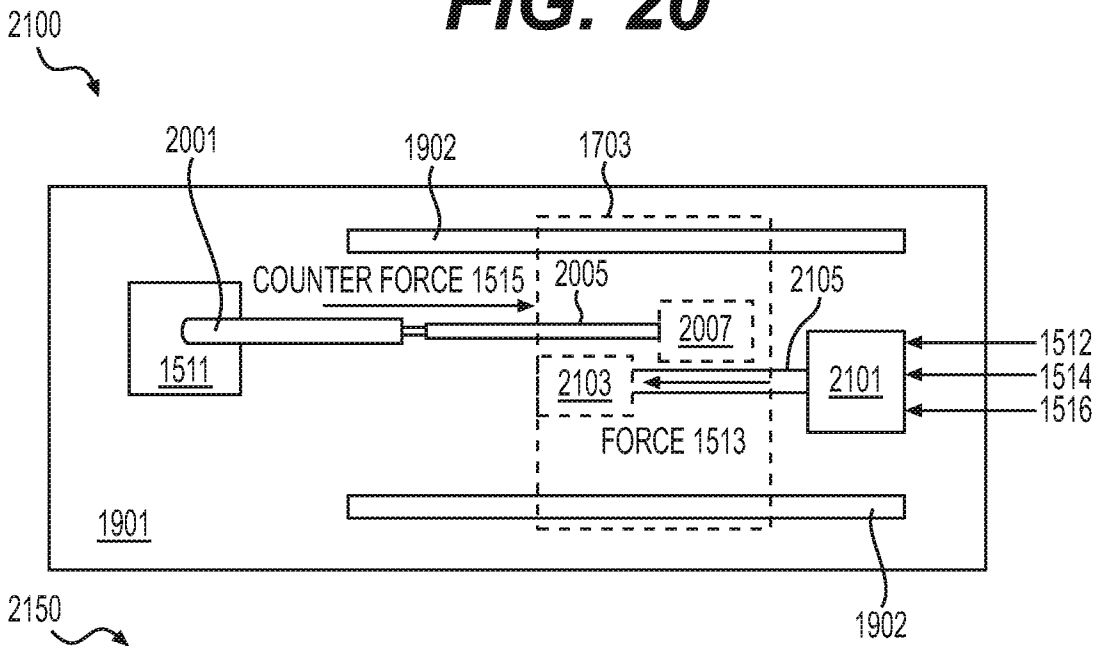
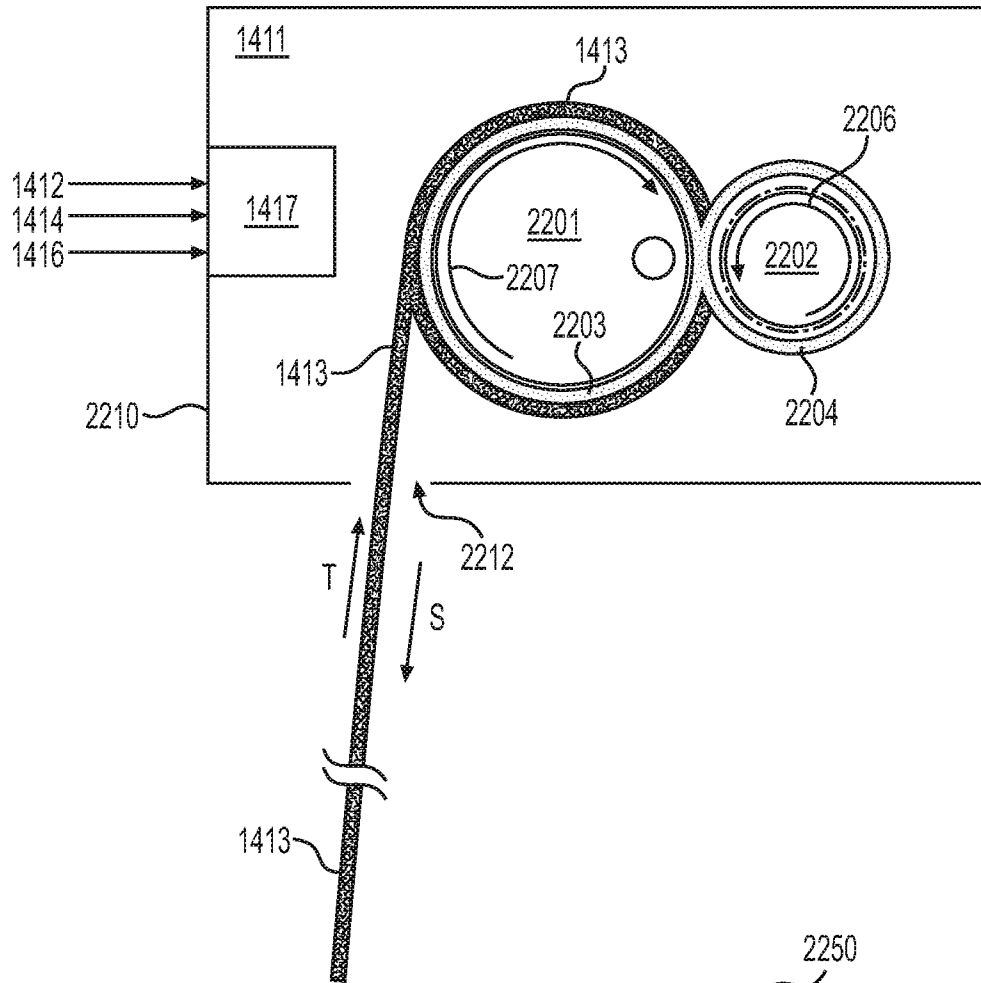

FIG. 21

2200



2250

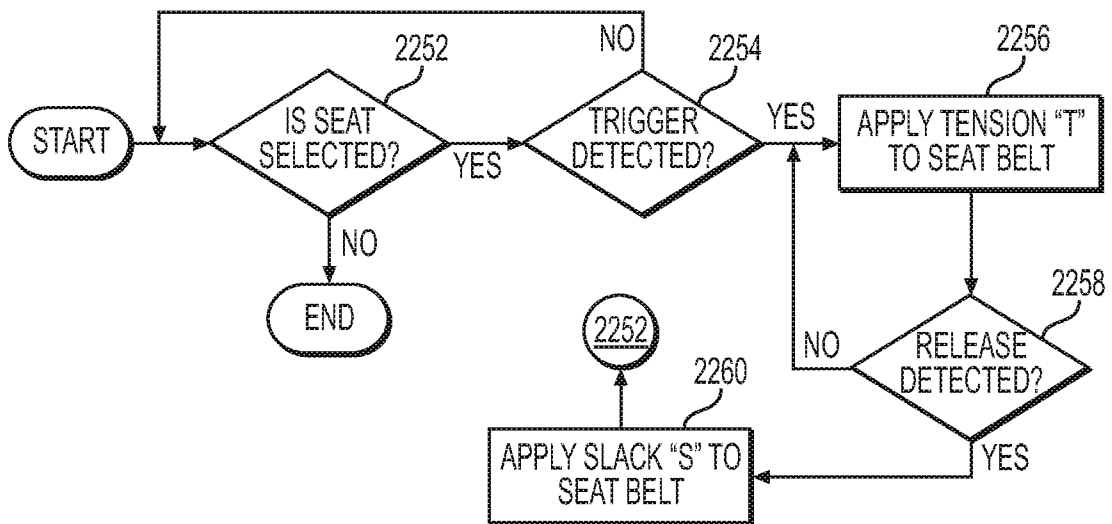

FIG. 22

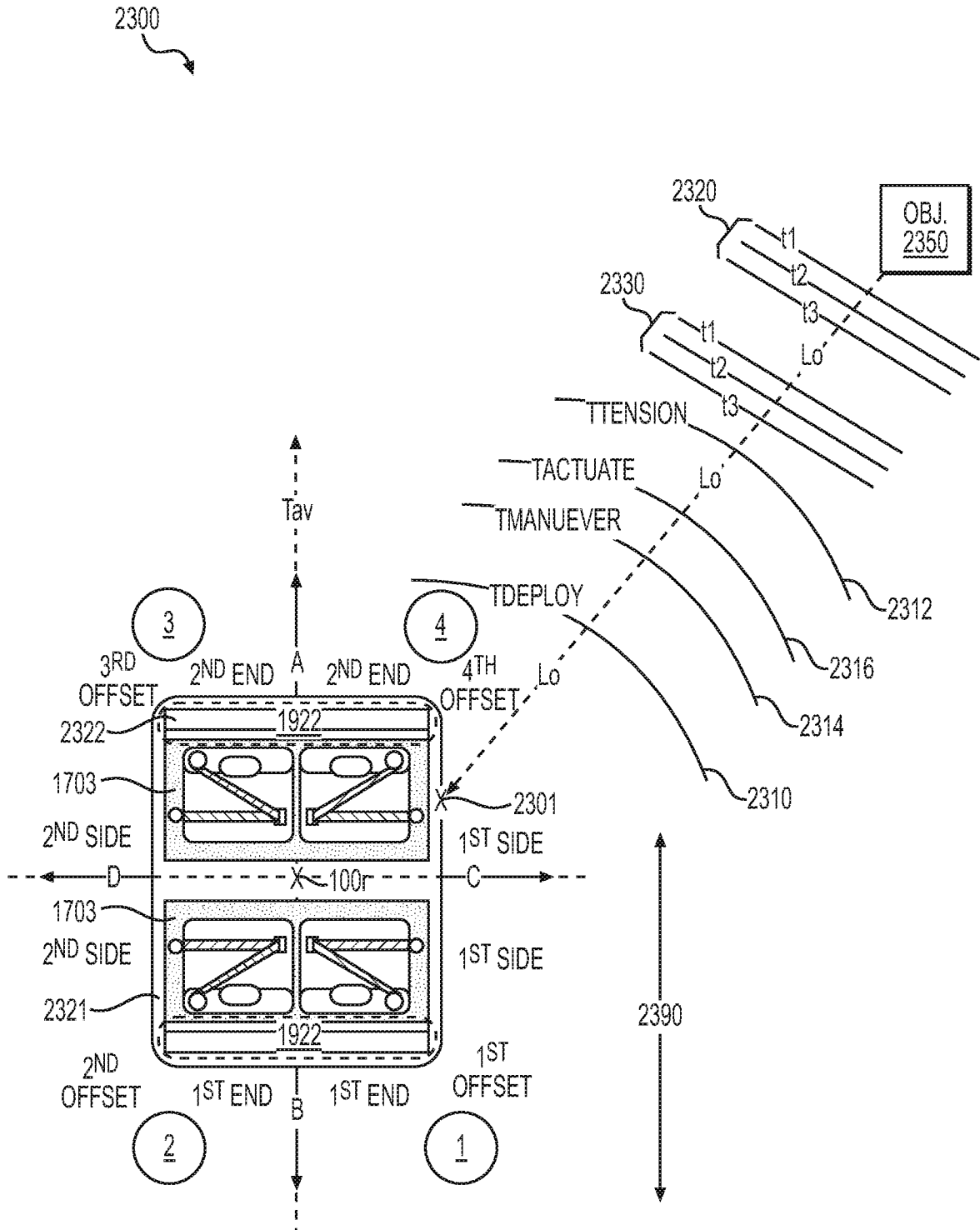

FIG. 23

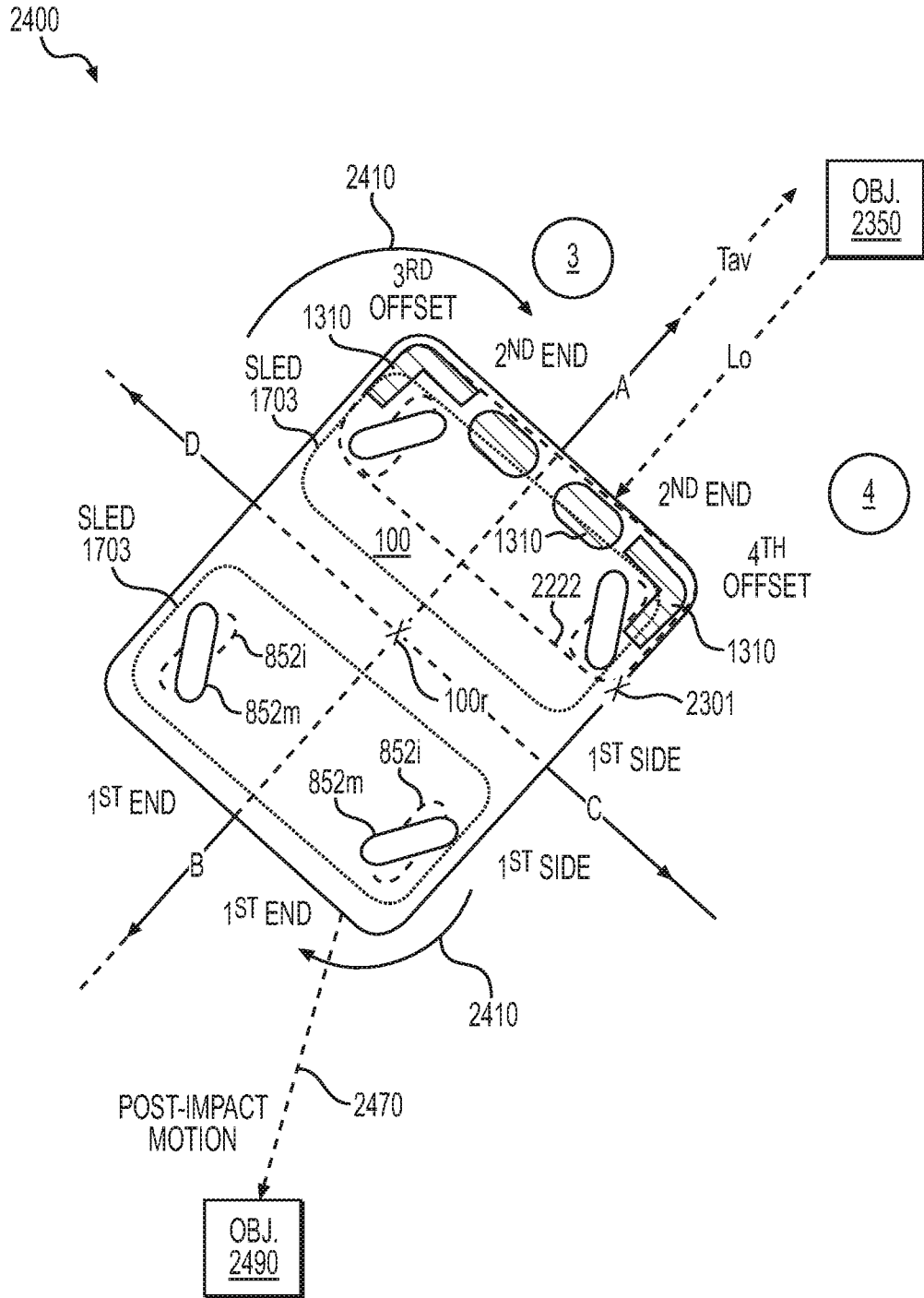

FIG. 24

2500

36/37

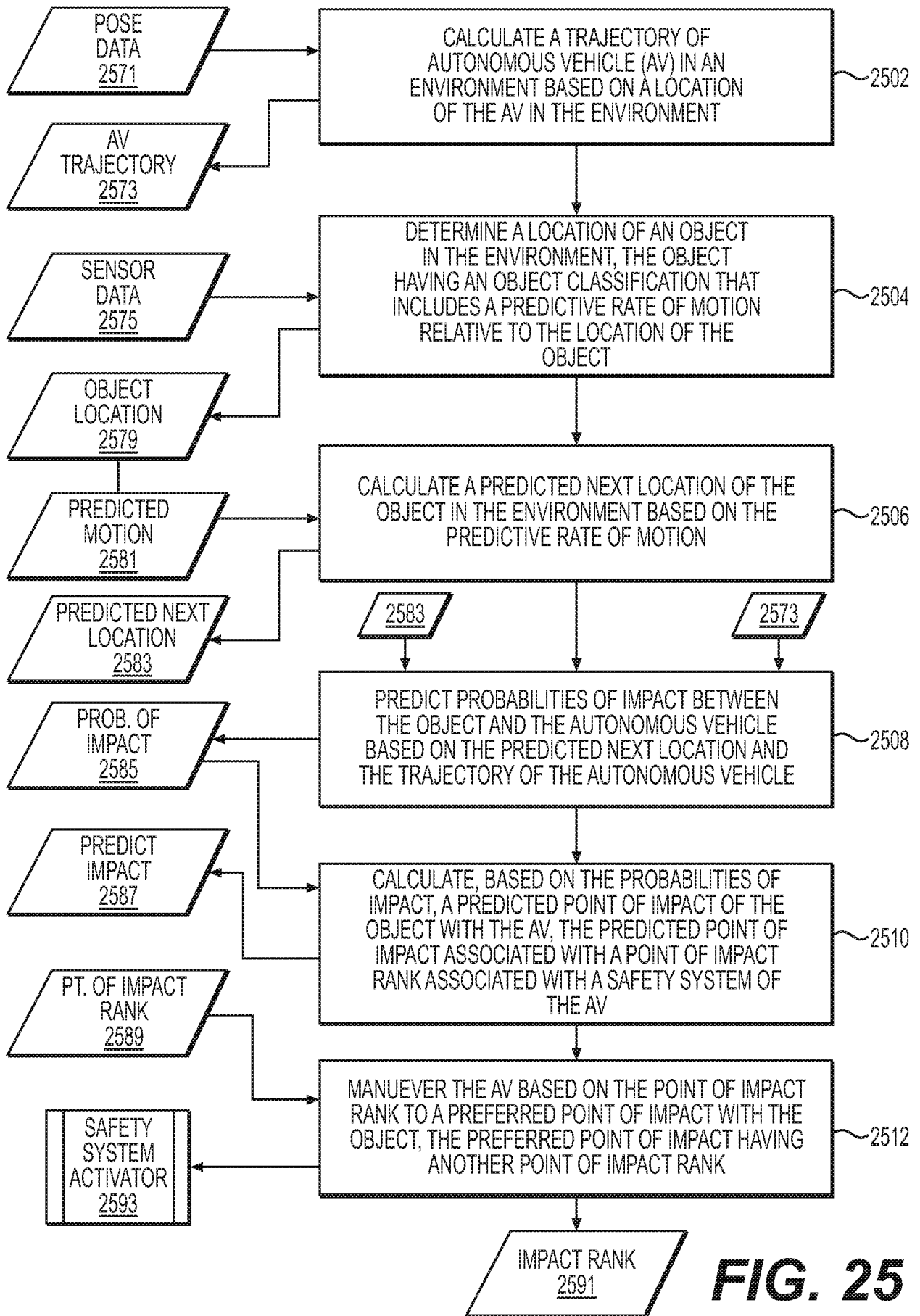

FIG. 25

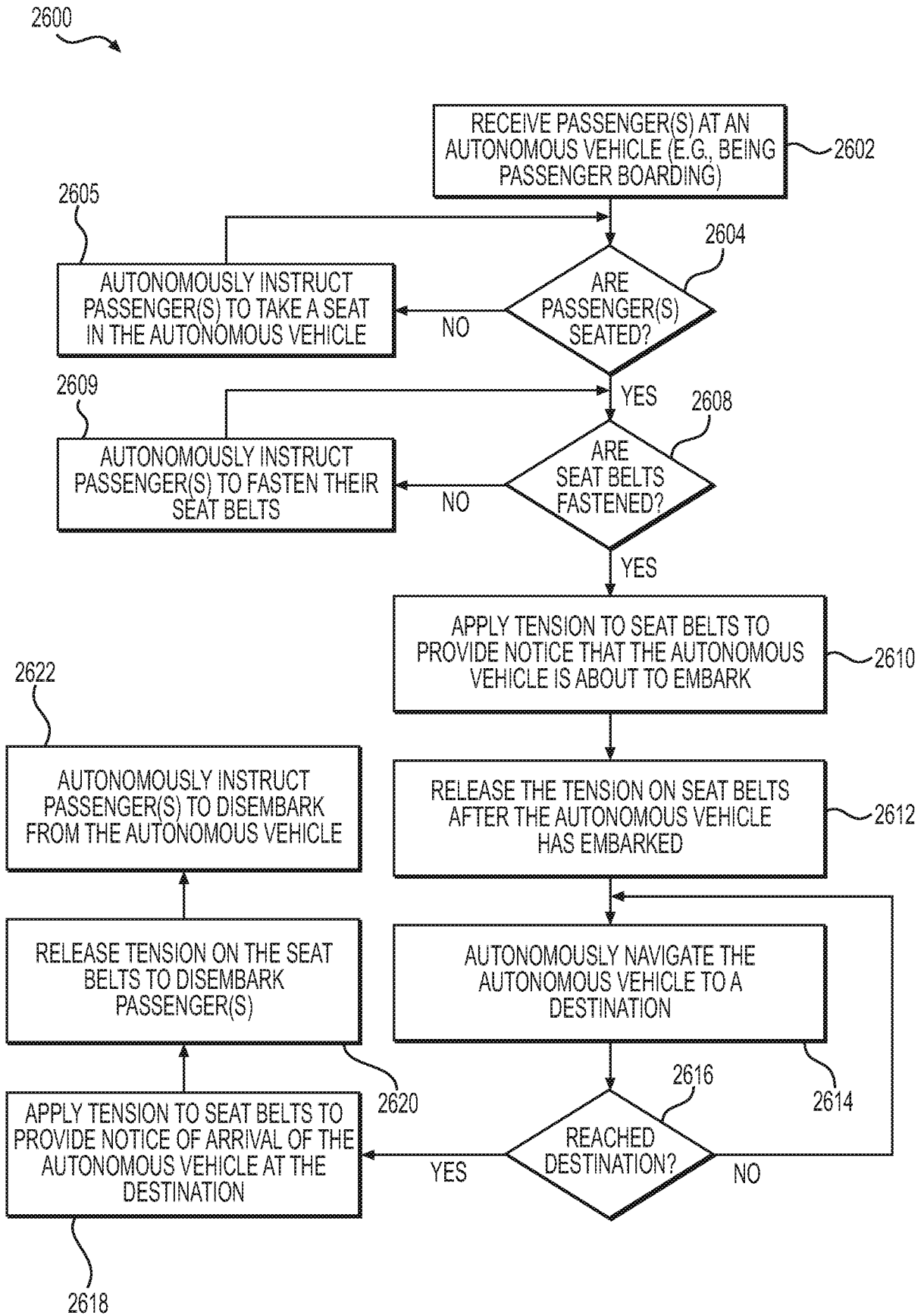

FIG. 26