

W. H. THOMS & H. W. DUMMERT.
 SIDE PLAY LINER FOR LOCOMOTIVE TRUCKS.
 APPLICATION FILED MAY 7, 1910.

970,138.

Patented Sept. 13, 1910.

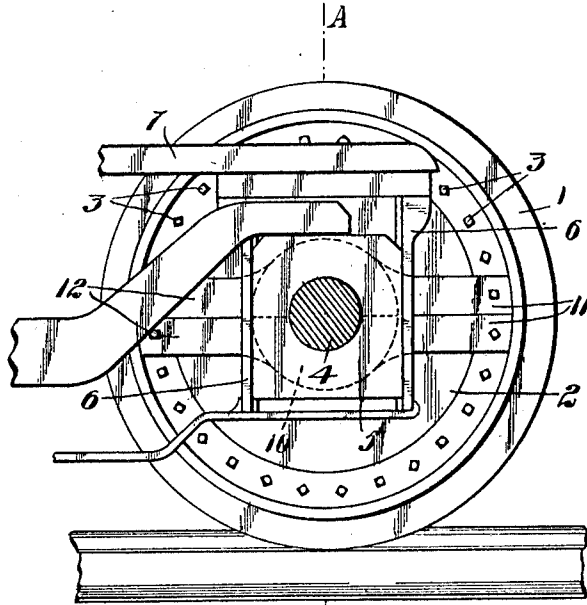

Fig. 1.

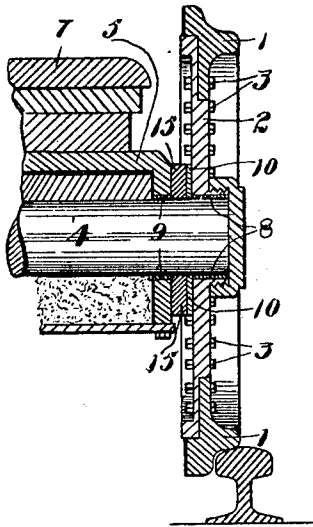

Fig. 2.

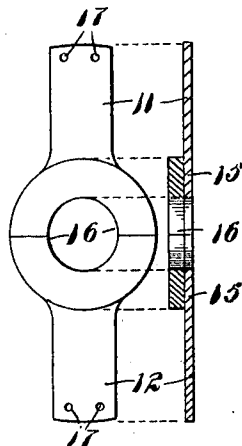

Fig. 3.

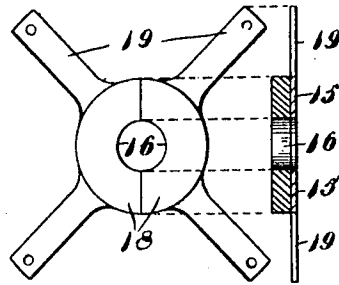

Fig. 6.

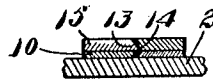

Fig. 5.

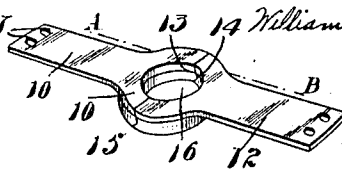

Fig. 4.

Witnesses.

Gene A. Sisson
B. A. Rembeck

Inventors.

William H. Thoms & Horace W. Dummert.

by

E. J. Hutchinson
Att'y

UNITED STATES PATENT OFFICE.

WILLIAM H. THOMS AND HORACE WALTER DUMMERT, OF CARLETON PLACE,
ONTARIO, CANADA.

SIDE-PLAY LINER FOR LOCOMOTIVE-TRUCKS.

970,138.

Specification of Letters Patent. Patented Sept. 13, 1910.

Application filed May 7, 1910. Serial No. 559,985.

To all whom it may concern:

Be it known that we, WILLIAM HENRY THOMS and HORACE WALTER DUMMERT, of the town of Carleton Place, in the county of Lanark, Province of Ontario, Dominion of Canada, subjects of the King of Great Britain, have invented certain new and useful Improvements in Side-Play Liners for Locomotive-Trucks; and we do hereby declare that the following is a full, clear, and exact description of the same.

The invention relates to improvements in side play liners for locomotive trucks, as described in the present specification and illustrated in the accompanying drawings that form part of the same.

The invention consists essentially in the novel construction and arrangement of parts whereby the liner may be placed in position without removing the wheel from the axle by rigidly supporting said liner with laterally arranged arms securely bolted to said wheel.

The objects of the invention are to obviate the necessity of removing the wheel to replace liners, to devise a liner of simple and durable construction and generally to effect economy in the maintenance of locomotive trucks.

In the drawings, Figure 1 is an inside elevation of a locomotive wheel and journal box showing the axle in cross section and the position of the liner arms. Fig. 2 is a vertical mid-section on the line A—B in Fig. 1. Fig. 3 is a plan view of the liner arms combined with a longitudinal sectional view of said arms and cross sectional view of the liner. Fig. 4 is a perspective detail of the liner and arms. Fig. 5 is a cross sectional view of the arms on the line A—B in Fig. 4, showing a portion of the wheel in section. Fig. 6 is a plan view of a modification of the liner arms.

Like numerals of reference indicate corresponding parts in each figure.

Referring to the drawings, 1 is the rim of the wheel, 2 is the web of the wheel securely attached to said rim by the bolts 3.

4 is the axle arranged in the center of the web of the wheel as customary.

5 is the journal box supported by the brackets 6 and slidably arranged therein, said brackets being rigidly secured to the truck beam 7. The axle 4 extends through

said journal box 5 into the center of the web 2.

8 is a bushing encircling the axle within the hub of the wheel.

9 is a bushing encircling the axle within the journal box casing.

10 is a side play liner, split centrally and in the form of a washer encircling the axle 4, and abutting the journal box 5.

11 and 12 are arms preferably longitudinally tongued and grooved in their inner sides 13 and 14 respectively and having the central expanded portion 15 forming the axle orifice 16, said central portion 15 being rigidly secured to the halves of the liner 10 by welding or other suitable process.

17 are bolt holes at the ends of the arms 11 and 12.

In separating the arms 11 and 12, each arm carries a half of the liner 10, said arms being brought together and in the central portion thereof encircling the axle 4, thus the liner 10 is between the journal box casing and said arms. The arms at the ends thereof are securely bolted to the web 2 and the rim 1, preferably by some of the same bolts 3 as are used for securing said rim and web together; therefore, the liner and its supporting arms are, to all intents and purposes a fixed part of the wheel structure and no screws or bolts are in the central portion thereof, with the result that the continuous side play cannot have any effect on said liner, other than the ordinary wear and tear and as it gradually becomes worn so much so that it must be replaced, the arms can be removed without difficulty, thus taking the liner away and substituting new parts. All this can be done without removing the wheel from the axle, as it is only necessary to remove those particular bolts 3 that secure said arms to the wheel.

In Fig. 6, a modification of the arrangement of arms is shown and the only difference being that from a central body 18, arms 19 extend outwardly and radially and are bolted to the wheel in the same manner, of course, it is obvious that any number of arms may be used.

What we claim as our invention is:—

1. In side play liners for locomotive trucks, the combination with the wheel, axle and the journal box through which said axle

extends, of a plate of metal split centrally and having a central axle orifice there-through and arms rigid with said plate of metal and extending laterally therefrom
5 and securely bolted to said wheel.

2. In side play liners for locomotive trucks, the combination with the wheel, axle and the journal box through which said axle extends, of a plate of metal split centrally
10 and having the axle orifice therethrough, and arms rigidly secured to the halves of said plate of metal respectively and formed in the central portion into a corresponding axle orifice and securely bolted to said
15 wheels.

3. In side play liners for locomotive trucks, the combination with the wheel, axle and the journal box through which said, axle extends, of a metal disk split centrally
20 having its halves form an axle orifice there-through and a plurality of arms extending from a central split body portion, the latter being securely welded to the halves of said

disk and the former being rigidly secured to said wheel adjacent to the rim thereof. 25

4. In side play liners for locomotive trucks, the combination with the wheel, axle and the journal box through which said axle extends, of a metal disk split centrally and having its halves form an axle orifice, and a
30 pair of arms centrally forming a corresponding axle orifice and rigidly secured to said disk halves respectively and having a tongue and groove formation respectively
35 on their inner sides and at their outer end bolt holes and bolts rigidly securing said arms to said wheel adjacent to the rim thereof.

Signed at Carleton Place, in the county of Lanark, this 27th day of April, 1910.

WILLIAM H. THOMS.
HORACE WALTER DUMMERT.

Witnesses:

J. S. L. MCNEELY,
HARRIET H. MCNEELY.