

June 6, 1961

M. SZABO

2,987,150

COLLAPSIBLE FLAT-LYING LUGGAGE HANDLE

Filed Feb. 11, 1960

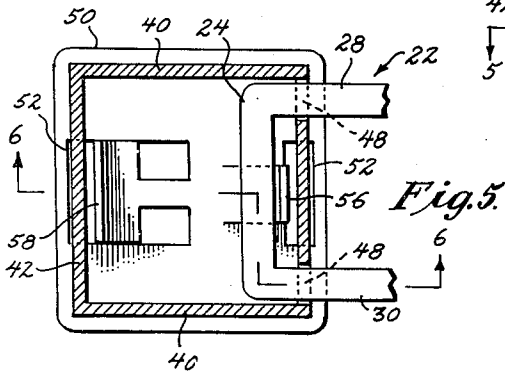
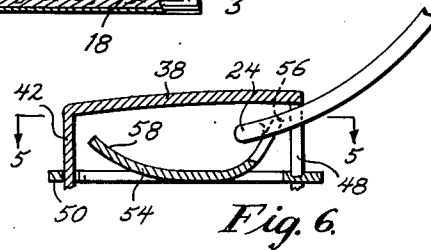
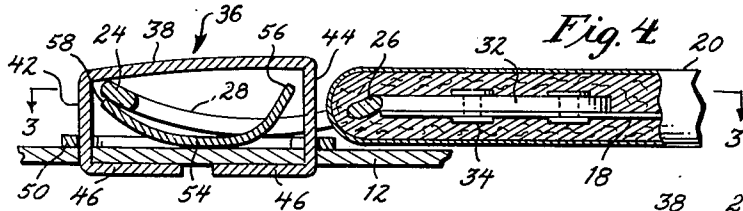
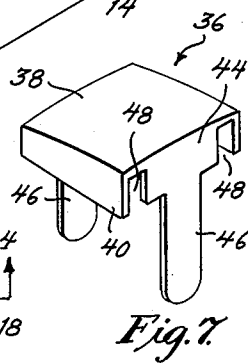
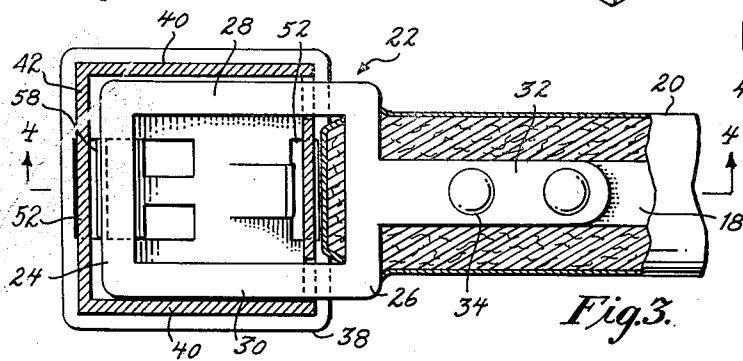
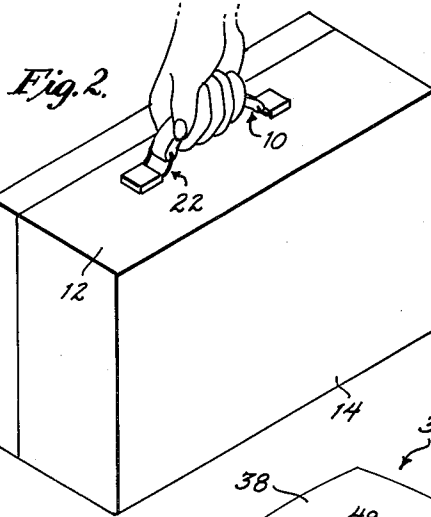
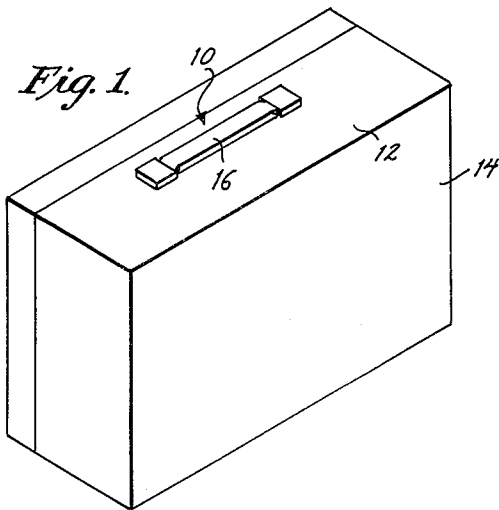

INVENTOR.
MARTON SZABO
BY *Max R. Millman*
ATTORNEY.

1

2,987,150

COLLAPSIBLE FLAT-LYING LUGGAGE HANDLE
 Marton Szabo, Broomall, Pa., assignor to Philadelphia
 Handle Company, Inc., Camden, N.J., a corporation
 of New Jersey

Filed Feb. 11, 1960, Ser. No. 8,008

2 Claims. (Cl. 190—57)

This invention relates to a handle for luggage, carrying cases and similar containers adapted to be pulled into an arched carrying position and to be readily collapsed into a flat non-carrying position against a wall of the container and constitutes an improvement over the handle disclosed in the Waterer Patent No. 1,736,640.

The primary object of the invention is to provide a flat-lying handle of the character described which is equipped with a means serving the dual function of assuring the return of the handle to the flattened non-carrying position from its arched carrying position when released and of preventing the rattling of the links at the ends of the handle in the guide housings therefor during all movements of the handle.

Another object of the invention is to provide a flat-lying handle in which the means to assure return of the handle to its flat non-carrying position and to restrain the rattling thereof in all positions is relatively simple, inexpensive to manufacture, assemble and replace if necessary, and positive in its action.

These and other objects of the invention will become more apparent as the following description proceeds in conjunction with the accompanying drawing, wherein:

FIGURE 1 is a perspective view of a container with the present handle thereon in the collapsed non-carrying position flat against a wall thereof;

FIGURE 2 is a view similar to FIGURE 1 showing the handle in the arched carrying position;

FIGURE 3 is a sectional view taken on the line 3—3 of FIGURE 4;

FIGURE 4 is a sectional view taken on the line 4—4 of FIGURE 3;

FIGURE 5 is a sectional view taken on the line 5—5 of FIGURE 6;

FIGURE 6 is a sectional view taken on the line 6—6 of FIGURE 5; and

FIGURE 7 is a perspective view of the anchor guide housing.

Specific reference is now made to the drawings wherein similar reference characters are used for corresponding elements throughout.

The present invention relates to a handle construction 10 of the type which is adapted to lie flat against a wall 12 of a piece of luggage 14 to which it is attached, as shown in FIGURE 1, and to be pulled into an arched carrying position by the hand as shown in FIGURE 2. It is to be understood that the term "luggage" as used herein means briefcases, trunks, handbags, suitcases and any and all carrying cases, such for example as portable radios, phonographs, etc. The handle includes an elongated grip portion 16 having an elongated strip or blade of steel spring 18 suitably covered by leather, plastic or other material 20. At each end of the grip, a link 22 is provided consisting of a concavo-convex rectangular member having transverse members 24 and 26 joined by longitudinal members 28 and 30. The transverse member 26 of each link 22 passes through a conventional hinge loop and includes a bar 32 which is riveted or otherwise secured as at 34 to each end of the spring 18.

To slidably anchor the links 22 on the wall 12 of the luggage 14, a guide housing 36, see FIGURE 7, is provided for each link, the housing being a hollow member having an upper wall 38, side walls 40, an outer end wall 42, an inner end wall 44 and ears 46 depending from

2

the end walls adapted to extend through suitable openings in and to be clinched about the wall 12 of the luggage as shown in FIGURE 4. The inner end wall 44 faces the opposite ends of the hand grip portion 16 and is provided with spaced vertically extending slots 48 which slidably receive the longitudinal members 28 and 30 of each link, the transverse member 24 thereof being disposed inside the housing 36.

A means is provided in the guide housing 36 to assure the return of the handle from the arched position of FIGURE 2 to the flat-lying position of FIGURE 1 when the hand releases the same and also to prevent rattling of the links 22 in the guide housings during all movements of the handle. This means includes a plate 50 with slots 52 through which the ears 46 of the guide housings extend so that when the ears 46 are clinched or otherwise secured in place to the luggage wall 12, the plate 50 is also fixed in place against the luggage wall.

Upstruck substantially centrally from the plate is an arcuate spring bar 54 which may be characterized as generally concavo-convex or bowed in the direction of the upper wall 38 of the guide housing 36. One end portion 56 of the resilient arcuate bar 54 terminates adjacent the inner end wall 44 and the upper wall 38 of the guide housing as shown clearly in FIGURES 4 and 6. The other end portion 58 terminates adjacent the outer end wall 42 and the upper wall 38 of the guide housing.

In use, when the hand exerts an upward pull on the hand grip portion 16 of the handle, the links are pulled outwardly of the guide housings, the transverse members 24 gliding noiselessly over the concave surface of the spring bar 54. When the handle is in its fully arched carrying position, the transverse members 24 bear against the one end portion 56 of the spring bar as shown in FIGURES 5 and 6. This one end portion 56 cooperates with the hand grip spring 18 to urge the transverse member 24 downwardly towards the low point of the spring bar 54 and away from the upper wall 38, so that when the hand releases the hand grip 16, the handle smoothly and noiselessly returns to the flattened non-carrying position. At this latter position, the other end portion 58 of the spring bar presses against the transverse member 24 of each link and urges it against the upper wall 38 of the guide housing thereby preventing the links from rattling in the guide housings in the flattened non-carrying position.

It will be understood that the temper of the hand grip spring 18 and that of the spring bar 54 may be varied to accommodate carrying cases of different loads so that the handle will remain comfortably in the raised or arched position during the carrying of the luggage and will smoothly and noiselessly return to the flattened non-carrying position automatically upon release thereof. Other variations may be made, as for example in the mode of attachment of the guide housings 36 and spring bar plates 50 to the luggage, without departing from the spirit of the invention and the scope of the appended claims.

I claim:

1. A collapsible luggage handle comprised of a longitudinally flexible hand grip portion capable of being arched to a carrying position and flattened to a non-carrying position, a spring in said hand grip portion normally urging the same into said flattened position, links connected to the opposite ends of said grip portion, guides adapted for attachment to luggage and slidably receiving said links, and means in said guides acting on said links to prevent said hand grip portion from remaining in the arched carrying position when released and to prevent said links from rattling in said guides when said hand grip portion is in the flattened non-carrying position, said guides each including an upper wall and said means including a concave-convex resilient member whose con-

3

cave surface faces said upper wall, said link riding over said concave surface, one free unsecured end portion of said resilient member engaging said link when the handle is in its arched carrying position and cooperatively with said hand grip spring urging said link downwardly away from said upper wall, the opposite free unsecured end portion of said resilient member engaging said link and urging it against said upper wall when said hand grip portion is in the flattened position.

2. The combination of claim 1 wherein one end wall of each guide includes spaced slots and each link includes longitudinal members slidable through said slots and a transverse member joining said longitudinal members, said link being also concave-convex and bowed in the same

4

direction as said resilient member, said transverse member being disposed in said guide and riding over said concave surface of said resilient member.

References Cited in the file of this patent

UNITED STATES PATENTS

1,736,640 Waterer ----- Nov. 19, 1929

FOREIGN PATENTS

306,230 Great Britain ----- Mar. 7, 1929
108,797 Sweden ----- Oct. 19, 1943
581,678 Germany ----- Aug. 1, 1933
335,346 Great Britain ----- Sept. 25, 1930

5
10