

J. S. Ironsfield, 2, Sheets, Sheet 1.

Card Grinder.

No. 102,236.

Patented Apr. 26. 1870.

FIG. 1.

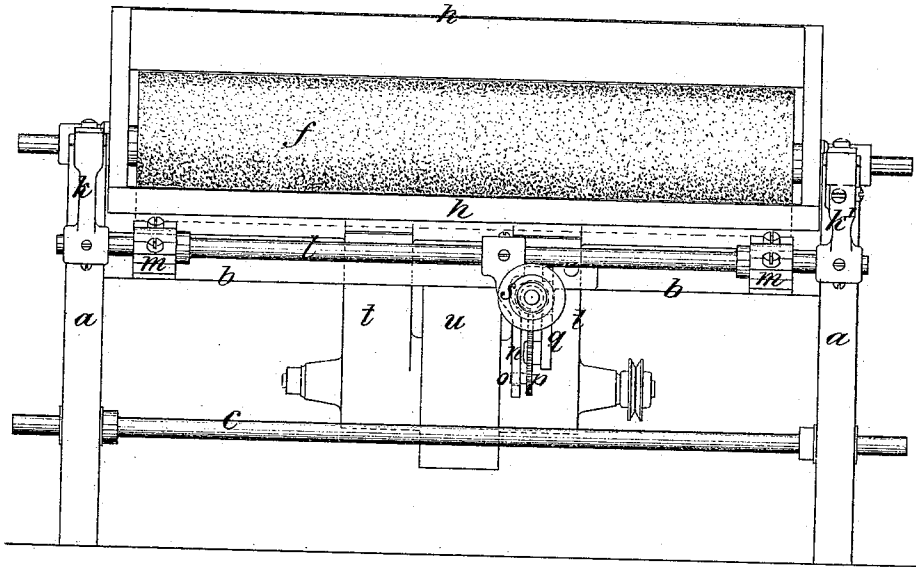
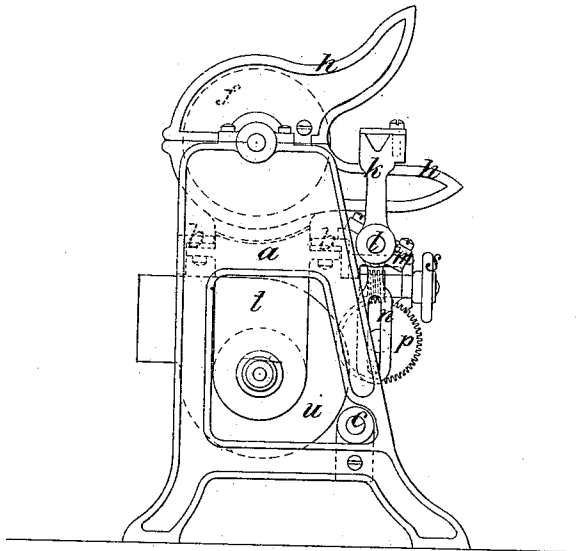

FIG. 2.



Witnesses.

Edward H. Dutton

Hugh G. Grant

Joseph S. Ironsfield

J. S. Ironsfield, 2, 1/2 Sheets, Sheet 2

Card Grinder.

No. 102236.

Patented Apr. 26. 1870.

FIG. 3.

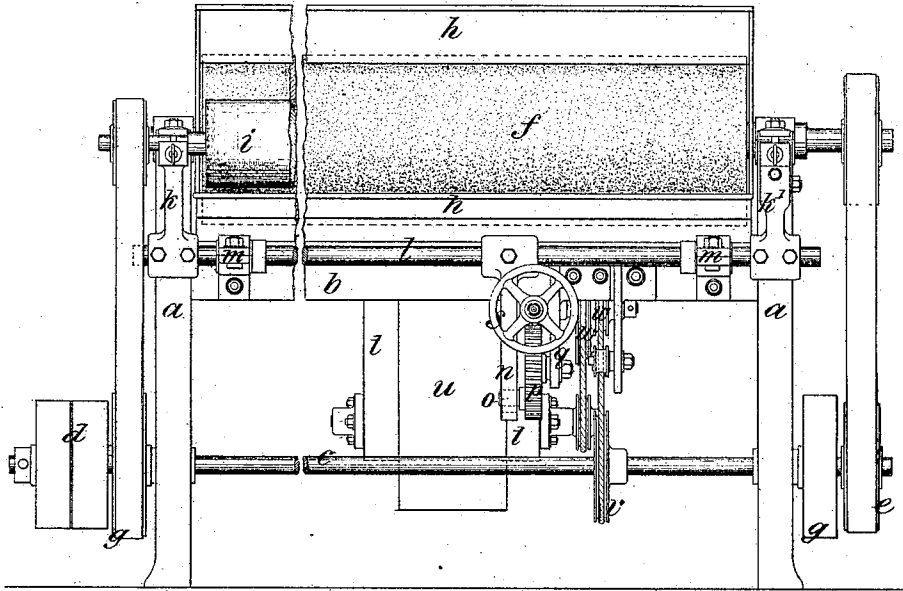

FIG. 4.

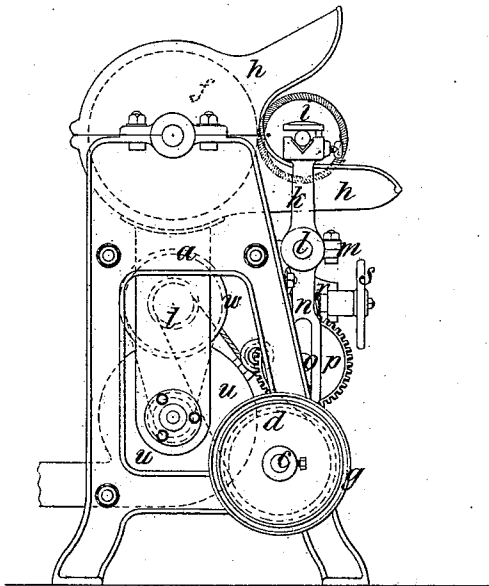
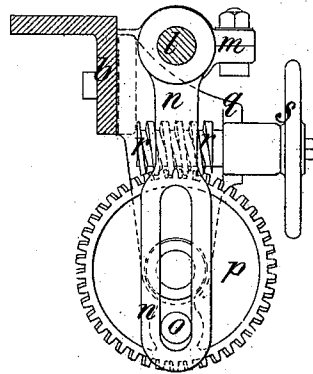

FIG. 5.



Witnesses.

Edward H. Dutton
Hugh G. Grant

Joseph S. Ironsfield

United States Patent Office.

JOSEPH STANDRING DRONSFIELD, OF OLDHAM, GREAT BRITAIN.

Letters Patent No. 102,236, dated April 26, 1870.

IMPROVEMENT IN CARD-GRINDER.

The Schedule referred to in these Letters Patent and making part of the same

I, JOSEPH STANDRING DRONSFIELD, of Oldham, in the county of Lancaster, in the Kingdom of Great Britain, have invented certain Improvements in Apparatus for Grinding "Cards" employed in the preparation of cotton and other fibrous materials, of which the following is a specification.

Nature and Objects of the Invention.

My invention relates to the machines employed to grind the cards or the card-rollers employed in carding-engines, and consists, in the first place, in supporting the roller which is to be ground in or upon two arms or bearers, which are fixed to a shaft mounted in bearings formed on or attached to the framing of the machine.

To the said shaft is fixed a lever, and a pin, carried by a worm-wheel, working in a slot formed in the said lever, so that when the worm-wheel is rotated, the card-roller will be caused to approach the grinding-roller, or to recede therefrom.

A fan, which is fitted to the machine, removes the dust.

A second portion of my invention consists in the combination and arrangement of the parts forming the complete machine.

Description of the Accompanying Drawings.

Figure 1 is a front elevation, and

Figure 2, an end elevation of the machine as represented by the model.

Figure 3 is a front elevation of a complete machine, represented as operating on a card-roller, and

Figure 4 is an end elevation of the same.

The machine is shown with a break in its width, as the said width may be varied to suit different lengths of rollers.

Figure 5 is an enlarged detached view of the aforesaid worm-wheel and slotted lever:

General Description.

Referring to the said figures, and more particularly to figs. 3 and 4—

a a are the end frames of the machine, which are connected together by cross-rails *b b*.

The driving-shaft *c* revolves in bearings formed in or attached to the end frames, and is fitted with fast and loose pulleys *d*, by means of which it is actuated, and with the pulley *e*, which drives the grinding-roller *f*, and also with the pulleys *g g*, which drive the card-roller.

The grinding-roller *f* is covered with emery or other suitable material, as is usual, and is fitted with the curved guards, casings, or covers *h h*, which are hinged together and inclose the grinding-roller, with the ex-

ception of a space at the front sufficient for the application and working of the card-roller.

A portion of one end of the card-roller is shown at *i*, in fig. 3, and in end view in fig. 4.

The end journals of the card-roller rest in bearings formed in the upper ends of the arms *k k*, the said bearings being either of the V-form, as shown, or of any other suitable form.

The said arms are fixed to the shaft *l*, which is mounted in the bearings *m m*, fixed to the cross-bar *b*, and on the said shaft is also fixed the slotted lever *n*, (see fig. 5,) the slot of which lever is entered by the pin *o*, fixed to the worm-wheel *p*.

The said worm-wheel is mounted on a stud carried by the bracket *q*, and is operated by the worm *r*.

When the said worm is rotated by means of the hand-wheel *s*, the pin *o* operates on the lever *n*, and causes the shaft *l* to turn in its bearings in either direction, according to the direction in which the hand-wheel is turned, and thus the card-roller, after being placed in its bearings, may be brought into contact with the grinding-roller, and may be fed toward the said roller as it is being ground, and may then be withdrawn, the parallelism of the card-roller and the grinding-roller being at all times maintained.

The space within the casing *h h* is connected by the side pipes *t* with the casing of the fan *u*.

This fan is driven by the band-wheel *v*, fixed on the shaft *c*, through an intermediate pair of band-wheels, *w w*, in order to increase the speed of the fan.

The fan removes the dust and particles of grit which may be discharged into the outer atmosphere through a suitable pipe or case, so that the machine may be worked in the carding-room, instead of in a special room, as is usual.

The method of driving the fan may be varied, as, for example, the fan may be driven direct from one of the journals of the grinding-roller.

The card-roller, not being a portion of the machine, does not appear in the model.

Claims.

I claim, as my invention—

1. The combination of the arms *k k*, the shaft *c*, the lever *n*, and the worm and wheel *r* and *p*, substantially as and for the purpose hereinbefore set forth.

2. The combination of the said arms, shaft, lever, worm, and worm-wheel with the fan and with the other parts of the machine, forming the complete card-grinding machine, substantially as hereinbefore set forth and as shown in figs. 1 and 2 of the drawings.

Witnesses: JOSEPH S. DRONSFIELD.

EDWARD K. DUTTON,
HUGH G. GRANT.