



INTERNATIONAL APPLICATION PUBLISHED UNDER THE PATENT COOPERATION TREATY (PCT)

<p>(51) International Patent Classification ⁵ : A61B 17/39, A61M 1/00</p>	<p>A1</p>	<p>(11) International Publication Number: WO 93/24066 (43) International Publication Date: 9 December 1993 (09.12.93)</p>
<p>(21) International Application Number: PCT/EP93/01258 (22) International Filing Date: 21 May 1993 (21.05.93) (30) Priority data: TO92A000454 27 May 1992 (27.05.92) IT (71) Applicant (for all designated States except US): L.I.C.A. DI ROSSO & C.S.N.C. [IT/IT]; Corso Susa, 36, I-10040 Caselette (IT). (72) Inventor; and (75) Inventor/Applicant (for US only): ROSSO, Luciano [IT/IT]; Corso Susa, 34, I-10040 Caselette (IT). (74) Agents: BUZZI, Franco et al.; Buzzi, Notaro & Antonielli d'Oulx s.r.l., Corso Fiume, 6, I-10133 Torino (IT).</p>	<p>(81) Designated States: AU, BB, BG, BR, CA, CZ, FI, HU, JP, KP, KR, KZ, LK, MG, MN, MW, NO, NZ, PL, RO, RU, SD, SK, UA, US, VN, European patent (AT, BE, CH, DE, DK, ES, FR, GB, GR, IE, IT, LU, MC, NL, PT, SE), OAPI patent (BF, BJ, CF, CG, CI, CM, GA, GN, ML, MR, NE, SN, TD, TG).</p> <p>Published With international search report.</p>	

(54) Title: METHOD AND APPARATUS FOR COSMETICAL TREATMENT OF THE HUMAN BODY THROUGH REMOVAL OF ADIPOSE MASSES

(57) Abstract

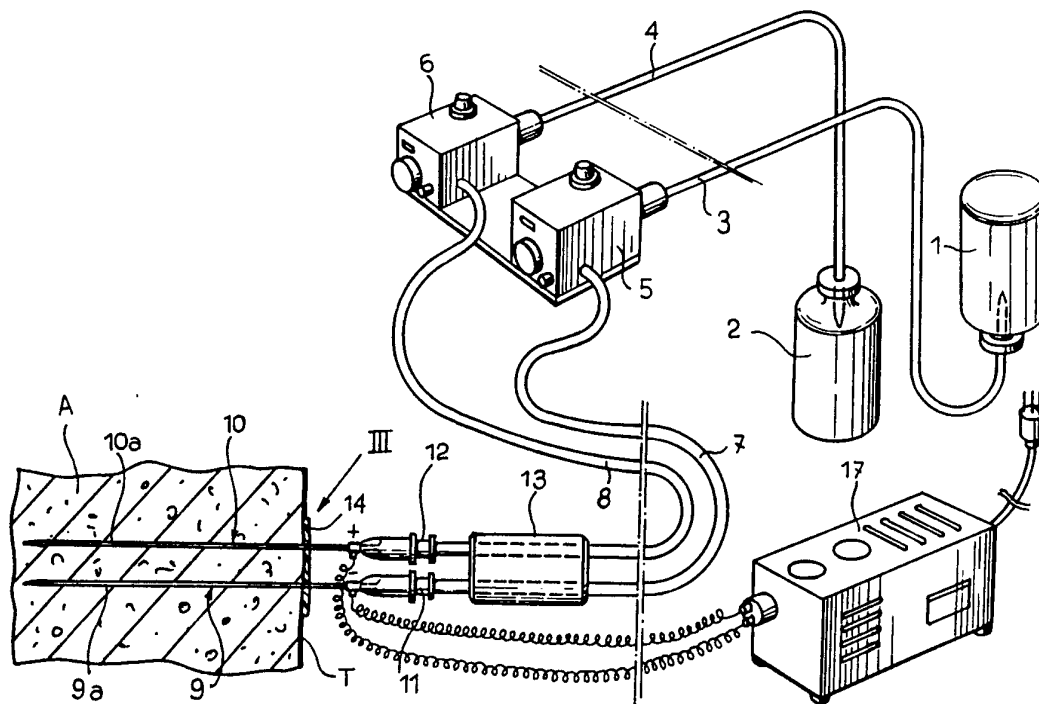

Method and apparatus for the cosmetic treatment of the human body through removal of the adipose tissue masses by means of the combined effect of the infiltration of a diluent solution and the application of a fluidizing perturbation within the adipose tissue (A), so as to enable the subsequent extraction thereof. The fluidizing perturbation is generated by the emission of electromagnetic waves by means of a pair of electrodes, at least one of which is directly associated to a tubular perforator (9, 10) through which the diluent solution is infiltrated and/or the fluidized adipose tissue is extracted.

FOR THE PURPOSES OF INFORMATION ONLY

Codes used to identify States party to the PCT on the front pages of pamphlets publishing international applications under the PCT.

AT	Austria	FR	France	MR	Mauritania
AU	Australia	GA	Gabon	MW	Malawi
BB	Barbados	GB	United Kingdom	NL	Netherlands
BE	Belgium	GN	Guinea	NO	Norway
BF	Burkina Faso	GR	Greece	NZ	New Zealand
BG	Bulgaria	HU	Hungary	PL	Poland
BJ	Benin	IE	Ireland	PT	Portugal
BR	Brazil	IT	Italy	RO	Romania
CA	Canada	JP	Japan	RU	Russian Federation
CF	Central African Republic	KP	Democratic People's Republic of Korea	SD	Sudan
CG	Congo	KR	Republic of Korea	SE	Sweden
CH	Switzerland	KZ	Kazakhstan	SK	Slovak Republic
CI	Côte d'Ivoire	LJ	Liechtenstein	SN	Senegal
CM	Cameroon	LK	Sri Lanka	SU	Soviet Union
CS	Czechoslovakia	LU	Luxembourg	TD	Chad
CZ	Czech Republic	MC	Monaco	TG	Togo
DE	Germany	MG	Madagascar	UA	Ukraine
DK	Denmark	MI	Mali	US	United States of America
ES	Spain	MN	Mongolia	VN	Viet Nam
FI	Finland				

- 1 -

"METHOD AND APPARATUS FOR COSMETICAL TREATMENT OF THE HUMAN BODY THROUGH REMOVAL OF ADIPOSE MASSES"

Technical field

The present invention is related to cosmetical treatments of the human body, and is more particularly concerned with a method for the removal of masses of adipose or fatty tissue, comprising a fluidizing step by means of the combined effect of infiltration of a diluent solution and application of a fluidizing perturbation within the adipose tissue, and a step of extraction of the fluidized adipose tissue.

Background art

A method of the above-mentioned type is known, for example, from EP-A-0418979. This known method, the final purpose of which is to produce autologous collagene from the human adipose tissue, contemplates for removal of the adipose tissue firstly the surgical cut of the body area to be treated, subsequently the introduction through the cut of a cannula for the infiltration of an anaesthetic and diluting solution, and then the insertion of a probe-lancet provided with a piezoelectric transducer for the generation of ultra-sounds. The ultra-sounds produce high frequency mechanical vibrations, and thus shock waves which impact the molecules of the endo-cellular substances thus causing the crushing of the adipocytes. A cellular emulsion is then produced, constituted by the contents of the fatty cells fragments, by inter-cellular substances and by the preliminarily injected solution. These substances are subsequently removed by means

- 2 -

of a "squeezing" action, whereby the liquified fat is drawn outside the surgical cuts by squeezing, energetically massaging the treated part by means of a roller device.

This method has a series of drawbacks: firstly, it consists of a real surgical operation, involving subsequent suture of the cuts and consequent dressings, as well as stay in hospital. Secondly, for these very reasons, the treatment can be only performed locally, and repetition thereof in different areas of the body can be made only after a certain period of time. Last but not least, the treatment requires the intervention of a specialized surgeon and of a medical staff.

Disclosure of the invention

The object of the present invention is to overcome the above drawbacks, and this object is achieved by virtue of a method of the above-referenced type, primarily characterized in that the subject fluidizing perturbation is generated by the emission of electro-magnetic waves through the adipose tissue by means of a pair of electrodes to at least one of which a tubular perforator is directly associated, by which the diluent solution is infiltrated and/or the fluidized adipose tissue is extracted.

Due to this idea of solution, the treatment according to the invention can be carried out without any surgical intervention and in a more complete way, intervening consecutively and in rapid succession on the different areas of the bodies requiring the treatment. The emission of electro-magnetic waves through the adipose tissue further

- 3 -

enables the obtention of a more efficient and more rapid fluidizing effect, deriving from the controlled and localized heating of the area under treatment. This effect is particularly appreciable if, according to a first embodiment of the invention, the electro-magnetic waves are radio-waves, in a frequency range conveniently comprised between 0,3 and 2 MHz.

According to an alternative embodiment, the frequency of the electro-magnetic waves is within the low-frequency range, conveniently comprised between 30 and 1000 Hz. In this case a less remarkable perturbing effect is obtained, nevertheless such as to effectively stimulate the tissues to be removed.

The invention is futher directed to an apparatus for carrying out the above method for cosmetical treatment.

Brief description of drawings

The invention will now be described in detail with reference to the annexed drawings, provided purely by way of non-limiting example, wherein:

- figure 1 is a diagrammatic perspective view of an apparatus for cosmetical treatment according to the invention,

- figure 2 is a view similar to figure 1 but in an enlarged scale, and

- 4 -

- figure 3 is partially sectioned view of a part of the apparatus.

Best mode for carrying out the invention

Referring to the drawings, references numerals 1 and 2 respectively designate a first closed vessel containing a fluidizing liquid (for example distilled water or a physiological solution possibly with diluent and/or anaesthetic components), and a second closed vessel intended to receive therein the adipose tissues removed by an area of the human body C. The vessels 1 and 2 are connected, through respective hoses 3 and 4, to a delivery peristaltic pump 5 and to a suction peristaltic pump 6, respectively, both provided in a known way with speed control. The two pumps 5 and 6, which can be replaced by pneumatic or other type pumps, are in turn connected by means of respective tubes 7 and 8 to a pair of thin tubular perforator needles 9 and 10, parallel to each other and provided with respective pipe fittings 11 and 12 carried, in a side by side configuration, by a handle 13. The handle 13 with the perforator needles 9 and 10 can be of disposable type.

The two perforators 9 and 10, which conveniently cross a centering and guide member 14, are made of an electrically conductive material and are lined, at least for part of their length, by an electrically and thermally insulating covering 9a, 10a, respectively, for instance made of silicone or the like.

Adjacent to the pipe fittings 11 and 12, the perforator needles 9 and 10 are electrically connected, externally or

- 5 -

internally, by means of respective conductor wires 15, 16, to an electro-magnetic wave generator 17. The perforator needles 9 and 10 thus also act as electrodes for the emission, during operation, of the electro-magnetic waves produced by the generator 17.

According to a first embodiment of the invention, the generator 17 includes an oscillator circuit, not shown but within the knowledge of the man skilled in the art, for the generation of radio waves, preferably in a frequency range comprised between 0,3 and 2 MHz (medium and intermediate waves).

According to another embodiment, the generator 17 produces, also in a way known per se, low frequency electro-magnetic waves, conveniently comprised in a range between 30 and 1000 Hz.

In a further embodiment, the generator 17 is designed so as to selectively generate electro-magnetic waves comprised between 30 Hz and 2 MHz, so as to cover both the low frequency range and the radio frequency range, under discretion of the operator and even in succession.

In use, the perforator needles 9 and 10 are introduced, through the skin T of the patient, within the adipose tissue A to be treated. The phase of introduction, which simply involves two small perforations, is facilitated by the centering and guide member 14, which during this operation can be maintained against the skin T.

- 6 -

Thereafter, after checking that no interference with veins or arteries has occurred, the peristaltic pump 5 is operated, so as to feed the diluent solution contained in the vessel 1 (normally without any need of pre-heating) into the adipose tissue A. Simultaneously the generator 17 is activated, which through the electrodes constituted by the perforators 9 and 10 emits electro-magnetic waves at low frequency, or radio-frequency, or in succession firstly at low frequency and subsequently radio frequency, within the adipose tissue A. As explained in the above, the low frequency is normally comprised between 30 and 1000 Hz and the radio frequency is in the range between 0,3 and 2 MHz.

The emission capacity of the generator 17 can be adjusted, and is variable for instance between 0 and 100 Watt.

The emission of the electro-magnetic waves through the adipose tissue A, combined with the action of the diluent solution delivered by the pump 5, carries out an effective fluidizing action of the adipose tissue which can then be removed by suction under the action of the pump 6, through the perforator 10, and collected within the vessel 2.

Operation of the generator 17 at low frequency performs a perturbing effect of stimulation of the tissue to be removed, while the radio-frequency accomplishes a more important and rapid fluidizing effect.

The coatings 9a and 10a of the perforator needles 9 and 10 permit to efficiently insulate, both electrically and thermally, the skin T which, as it is known, is the only

- 7 -

sensitive part in the crossing area of the perforators 9 and 10.

The possibility of adjusting the peristaltic pumps 5 and 6 and the electro-magnetic wave generator 17 enables a wide adjustment of the treatment, which can be dosed as a function of the specific characteristics of the patient.

Naturally, the details of construction and the embodiments of the apparatus can be widely varied with respect to what has been disclosed and illustrated, without thereby departing from the scope of the present invention.

Thus, for example, according to another embodiment not shown in the drawings, only a single perforator instead of two can be employed, connected by means of a two-way connector to both tubes 7 and 8, and thus to both pumps 5, 6 and vessels 1, 2. In this case, the second electrode will be constituted by an outer plate to be placed in contact with the body C and of course also connected to the generator 17, and the fluidizing and extraction steps of the adipose tissue A will be carried out in a cyclically alternated way, operating in succession firstly one and then the other of the pumps 5, 6.

Moreover, in this case, a single reversible peristaltic (or of a different type) pump can be used, instead of two separate pumps.

According to a further embodiment, a plurality of needles can be employed, arranged according to one or more formations and carried by the handle 13.

- 8 -

Lastly, it is to be pointed out that the electro-magnetic wave generator 17 can be operated during the fluidizing phase either continuously, or so as to produce pulses or pulse trains of variable length, separated by pauses, also variable, adjusted manually or by means of a programmable micro-processor incorporated in the apparatus and within the knowledge of the man skilled in the art.

- 9 -

CLAIMS

1. A method for the cosmetical treatment of the human body (C) through removal of adipose tissue masses (A), comprising a fluidizing step by means of the combined effect of the infiltration of a diluent solution and the application of a fluidizing perturbation within the adipose tissue (A), and a step of extraction of the fluidized adipose tissue (A), characterized in that the said fluidizing perturbation is produced by the generation of electro-magnetic waves through the adipose tissue (A) by means of a pair of electrodes, to at least one of which a tubular perforator (9, 10) is directly associated, by which the diluent solution is infiltrated and/or the fluidized adipose tissue is extracted.
2. Proceeding according to claim 1, characterized in that the electro-magnetic waves are generated in a frequency range comprised between 30 Hz and 2 MHz.
3. A method according to claim 1, characterized in that the electro-magnetic waves are generated at low frequency comprised in a range between 30 and 1000 Hz.
4. A method according to claim 1, characterized in that the electro-magnetic waves are radio-waves in a frequency range of comprised between 0,3 and 2 MHz.
5. A method according to claim 1 or claim 2, characterized in that the generation of electro-magnetic waves is performed at a variable capacity.

- 10 -

6. A method according to claim 1, characterized in that the electro-magnetic waves are generated continuously.

7. A method according to claim 1, characterized in that the electro-magnetic waves are generated under pulses or pulse trains.

8. Apparatus for the cosmetical treatment of the human body (C) through removal of adipose tissue masses (A), comprising means for infiltrating a diluent solution and means for applying a fluidizing perturbation within the adipose tissue (A), and means for the extraction of the fluidized adipose tissue (A), characterized in that the means for applying the fluidizing perturbation comprise an electro-magnetic wave generator (17) and a pair of electrodes, to at least one of which is directly associated a tubular perforator (9, 10) for the infiltration of the diluent solution and/or for extraction of the fluidized adipose tissue.

9. Apparatus according to claim 8, characterized in that to the said at least one tubular perforator (9, 10) at least one hose (7, 8) is connected, to which a peristaltic pump (5, 6) is operatively associated.

10. Apparatus according to claim 9, characterized in that a closed vessel (1, 2) is connected to the said at least one hose (7, 8).

11. Apparatus according to claim 8, characterized in that it comprises a pair of tubular perforators (9, 10) to each of which a respective electrode is associated.

- 11 -

12. Apparatus according to claim 8 or claim 11, characterized in that the or each tubular perforator (9, 10) has at least an outer portion covered by a thermal and electric insulating material (9a, 10a).

13. Apparatus according to claim 8, characterized in that the or each peristaltic pump (5, 6) has a variable speed.

14. Apparatus according to claim 8, characterized in that the electro-magnetic wave generator (17) is of variable capacity.

15. Apparatus according to claim 8, characterized in that the electro-magnetic wave generator comprises a low frequency oscillator in a frequency range comprised between 30 and 1000 Hz.

16. Apparatus according to claim 8 or claim 15, characterized in that the electro-magnetic wave generator comprises a radio-frequency oscillator in a frequency range comprised between 0,3 and 2 MHz.

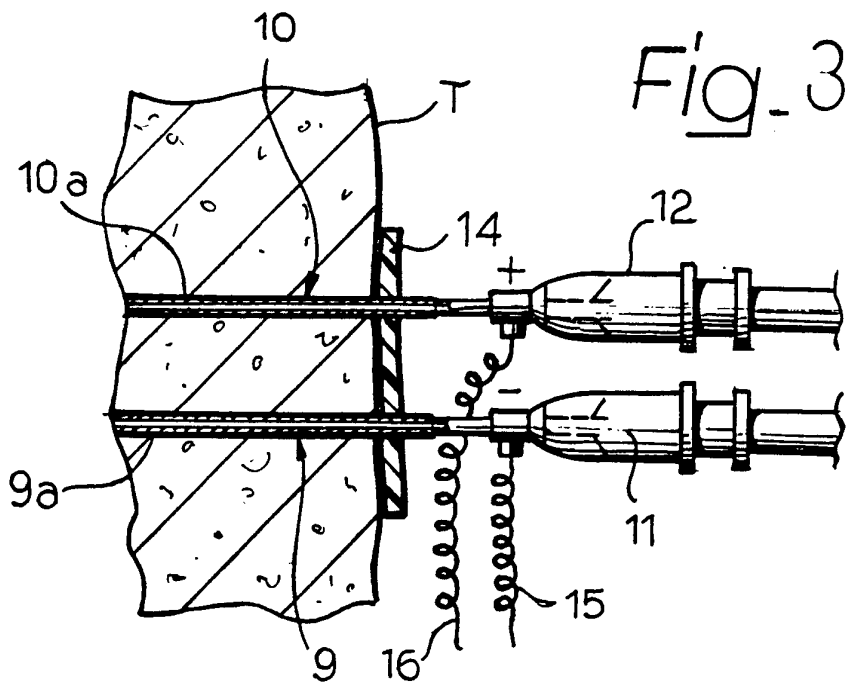
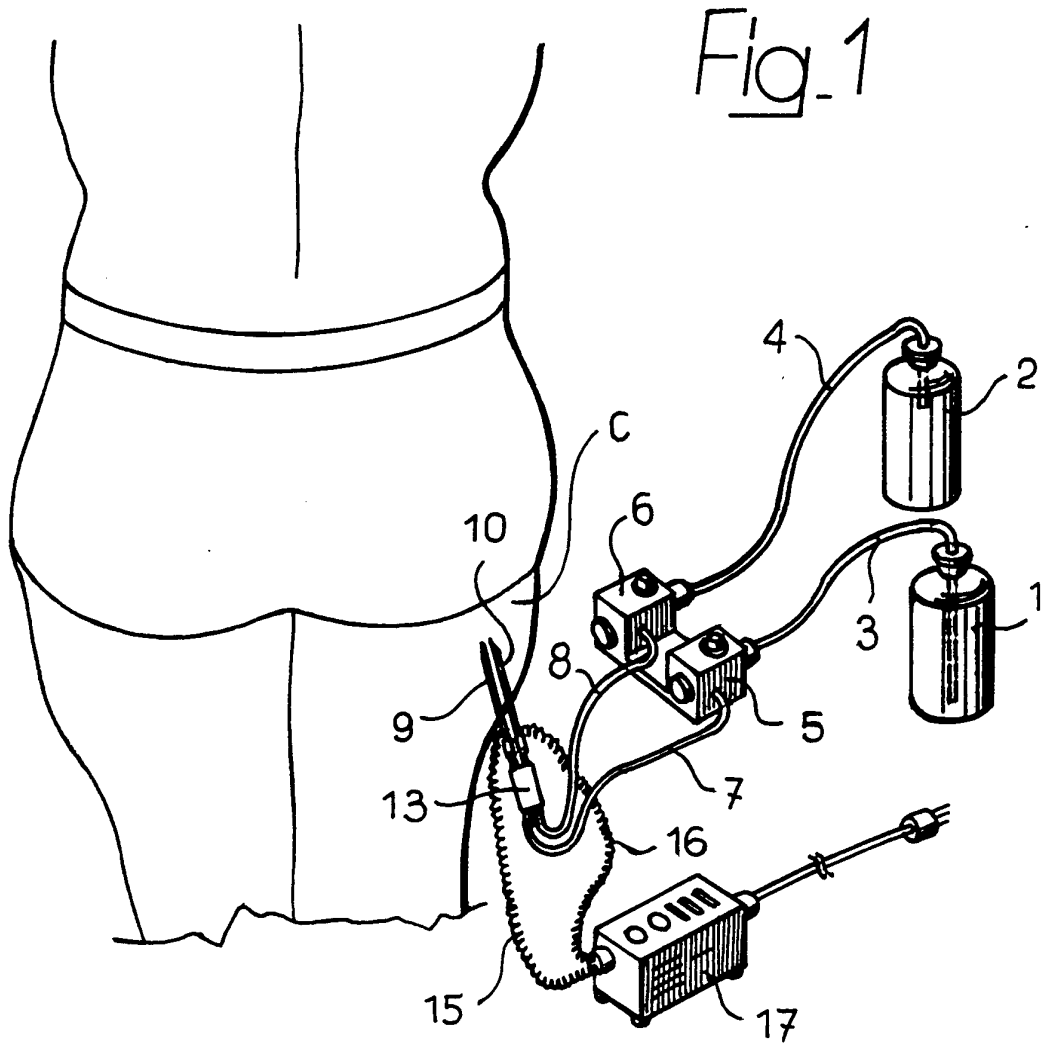
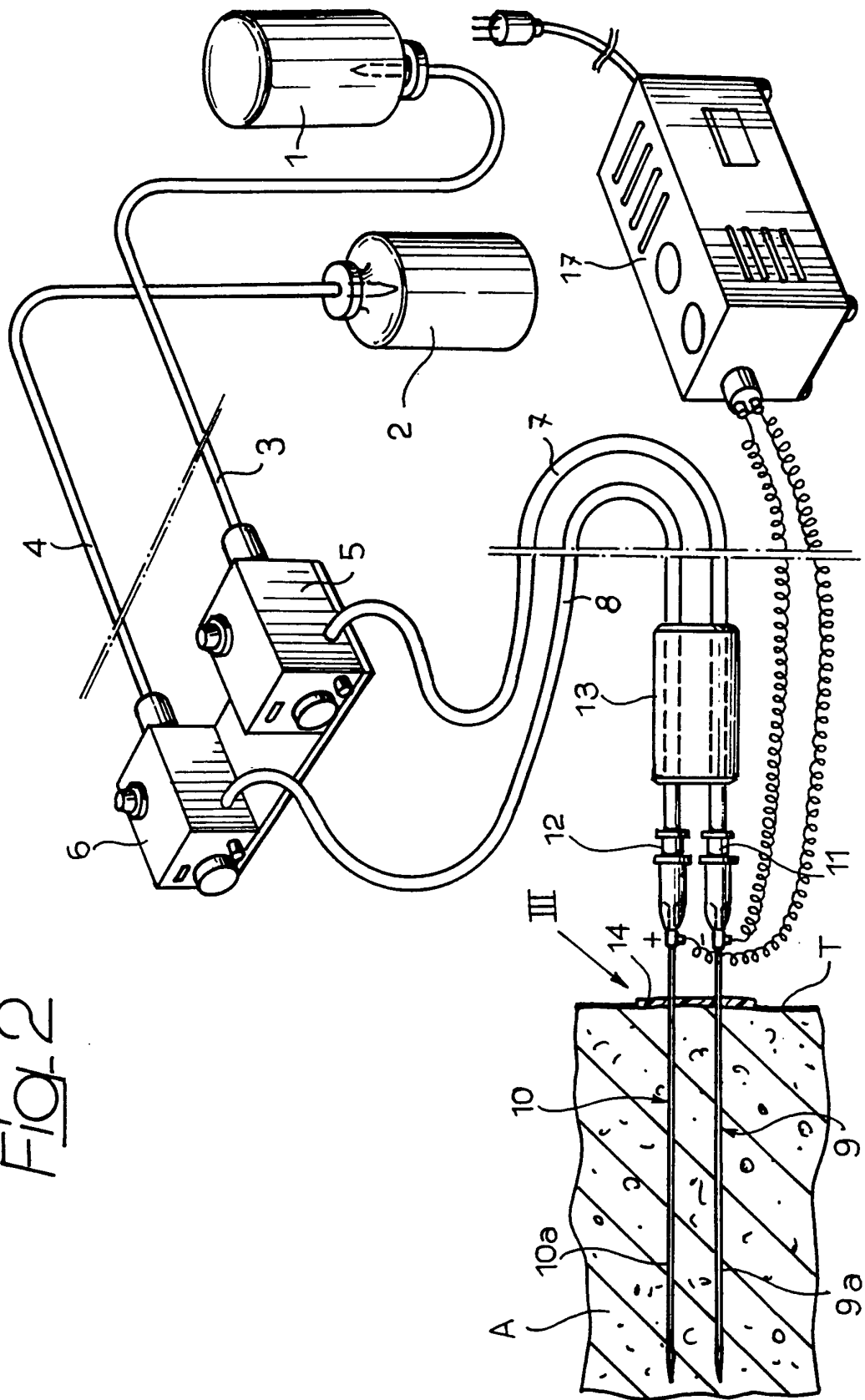

Fig. 2



INTERNATIONAL SEARCH REPORT

PCT/EP 93/01258

International Application No

I. CLASSIFICATION OF SUBJECT MATTER (if several classification symbols apply, indicate all) ⁶ According to International Patent Classification (IPC) or to both National Classification and IPC Int.Cl. 5 A61B17/39; A61M1/00		
II. FIELDS SEARCHED		
Minimum Documentation Searched ⁷		
Classification System	Classification Symbols	
Int.Cl. 5	A61B ; A61M ; A61N	
Documentation Searched other than Minimum Documentation to the extent that such Documents are Included in the Fields Searched ⁸		
III. DOCUMENTS CONSIDERED TO BE RELEVANT⁹		
Category ¹⁰	Citation of Document, ¹¹ with indication, where appropriate, of the relevant passages ¹²	Relevant to Claim No. ¹³
A	DE,B,1 143 937 (DEUTSCHE MICROWELLEN GMBH) 1 July 1960 see claim; figures ---	8, 9, 11, 12
A	WO,A,9 112 774 (HERAEUS LASERSONICS INC.) 5 September 1991 see abstract; figure 1 ---	8
A	EP,A,0 331 313 (PARISI) 6 September 1989 see column 4, line 46 - column 5, line 3 see column 5, line 31 - line 44; figures -----	8
<p>¹⁰ Special categories of cited documents :</p> <p>"A" document defining the general state of the art which is not considered to be of particular relevance</p> <p>"E" earlier document but published on or after the international filing date</p> <p>"I" document which may throw doubts on priority claim(s) or which is cited to establish the publication date of another citation or other special reason (as specified)</p> <p>"O" document referring to an oral disclosure, use, exhibition or other means</p> <p>"P" document published prior to the international filing date but later than the priority date claimed</p> <p>"T" later document published after the international filing date or priority date and not in conflict with the application but cited to understand the principle or theory underlying the invention</p> <p>"X" document of particular relevance; the claimed invention cannot be considered novel or cannot be considered to involve an inventive step</p> <p>"Y" document of particular relevance; the claimed invention cannot be considered to involve an inventive step when the document is combined with one or more other such documents, such combination being obvious to a person skilled in the art.</p> <p>"&" document member of the same patent family</p>		
V. CERTIFICATION		
Date of the Actual Completion of the International Search 05 AUGUST 1993		Date of Mailing of this International Search Report 13. 08. 93
International Searching Authority EUROPEAN PATENT OFFICE		Signature of Authorized Officer VILLENEUVE J.M.

INTERNATIONAL SEARCH REPORT

International application No.

PCT/EP 93/01258

Box I Observations where certain claims were found unsearchable (Continuation of item 1 of first sheet)

This international search report has not been established in respect of certain claims under Article 17(2)(a) for the following reasons:

1. Claims Nos.: 1-7
because they relate to subject matter not required to be searched by this Authority, namely:
Please see Rule 39.1 (iv) PCT
Method for treatment of the human or animal body by surgery
2. Claims Nos.:
because they relate to parts of the international application that do not comply with the prescribed requirements to such an extent that no meaningful international search can be carried out, specifically:
3. Claims Nos.:
because they are dependent claims and are not drafted in accordance with the second and third sentences of Rule 6.4(a).

Box II Observations where unity of invention is lacking (Continuation of item 2 of first sheet)

This International Searching Authority found multiple inventions in this international application, as follows:

1. As all required additional search fees were timely paid by the applicant, this international search report covers all searchable claims.
2. As all searchable claims could be searched without effort justifying an additional fee, this Authority did not invite payment of any additional fee.
3. As only some of the required additional search fees were timely paid by the applicant, this international search report covers only those claims for which fees were paid, specifically claims Nos.:
4. No required additional search fees were timely paid by the applicant. Consequently, this international search report is restricted to the invention first mentioned in the claims; it is covered by claims Nos.:

Remark on Protest

- The additional search fees were accompanied by the applicant's protest.
- No protest accompanied the payment of additional search fees.

**ANNEX TO THE INTERNATIONAL SEARCH REPORT
ON INTERNATIONAL PATENT APPLICATION NO.**

EP 9301258
SA 74338

This annex lists the patent family members relating to the patent documents cited in the above-mentioned international search report. The members are as contained in the European Patent Office EDP file on
The European Patent Office is in no way liable for these particulars which are merely given for the purpose of information. 05/08/93

Patent document cited in search report	Publication date	Patent family member(s)	Publication date
DE-B-1143937		None	
WO-A-9112774	05-09-91	US-A- 4985027	15-01-91
		US-A- 5102410	07-04-92
		EP-A- 0470213	12-02-92
		JP-T- 5502605	13-05-93
EP-A-0331313	06-09-89	US-A- 4886491	12-12-89
		JP-A- 1262854	19-10-89