



US 20170080245A1

(19) **United States**

(12) **Patent Application Publication**  
**DIMINO et al.**

(10) **Pub. No.: US 2017/0080245 A1**

(43) **Pub. Date: Mar. 23, 2017**

(54) **TWO-PART PULSED ELECTROMAGNETIC FIELD APPLICATOR FOR APPLICATION OF THERAPEUTIC ENERGY**

*A47G 9/10* (2006.01)

*A41D 13/12* (2006.01)

(52) **U.S. Cl.**

CPC ..... *A61N 2/02* (2013.01); *A41D 13/1245* (2013.01); *A42B 1/242* (2013.01); *A47G 9/10* (2013.01); *A41D 2400/32* (2013.01)

(71) Applicants: **Andre' A. DIMINO**, Woodcliff Lake, NJ (US); **Matthew E. DRUMMER**, Fort Lee, NJ (US)

(72) Inventors: **Andre' A. DIMINO**, Woodcliff Lake, NJ (US); **Matthew E. DRUMMER**, Fort Lee, NJ (US)

(57)

**ABSTRACT**

Pulsed electromagnetic field (PEMF) apparatuses and methods of making and using them. In particular, described herein are two-part PEMF apparatuses that include a self-contained, lightweight, small, compact (e.g., in some variations, wearable) generator unit that is adapted to releasably and replaceably mate with an applicator unit. The generator unit typically includes a power source and a controller that generated PEMF waveforms to be applied, including the shape and timing of the PEMF waveforms. The applicator unit typically includes a radio frequency (RF) power amplifier, a loop antenna, and impedance matching circuitry for matching the impedances for the connection between the antenna loop and the RF power amplifier. Thus, the generator module may control the application of PEMF signals without requiring impedance matching between the separable generator unit and the applicator unit. The applicator unit can include a plurality of variable capacitors that can be used to tune the PEMF signals.

(21) Appl. No.: **15/137,737**

(22) Filed: **Apr. 25, 2016**

**Related U.S. Application Data**

(63) Continuation of application No. 14/688,602, filed on Apr. 16, 2015, now Pat. No. 9,320,913.

(60) Provisional application No. 61/980,433, filed on Apr. 16, 2014, provisional application No. 62/086,987, filed on Dec. 3, 2014.

**Publication Classification**

(51) **Int. Cl.**

*A61N 2/02* (2006.01)

*A42B 1/24* (2006.01)

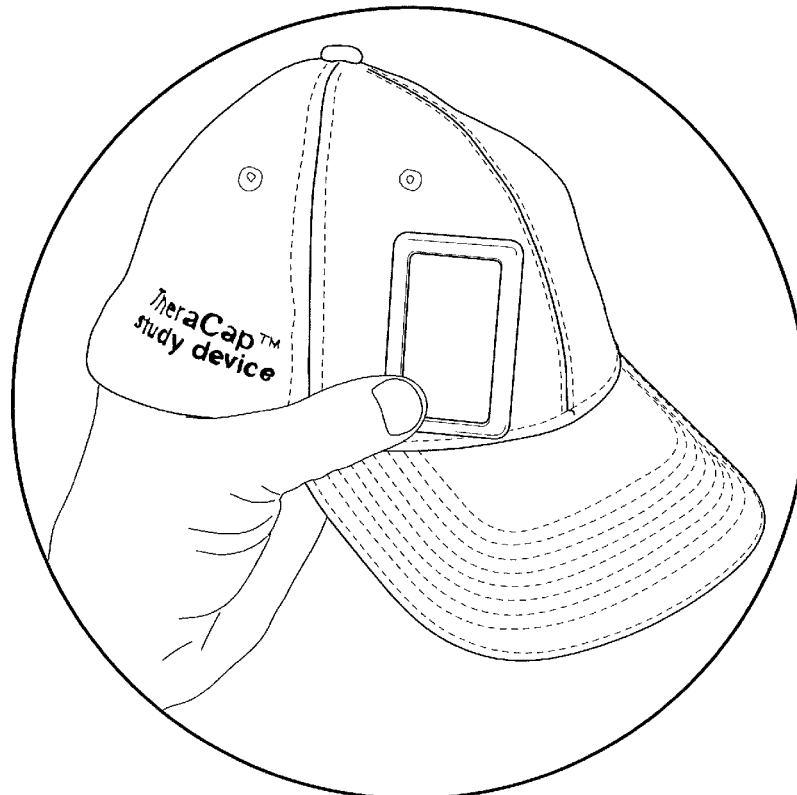

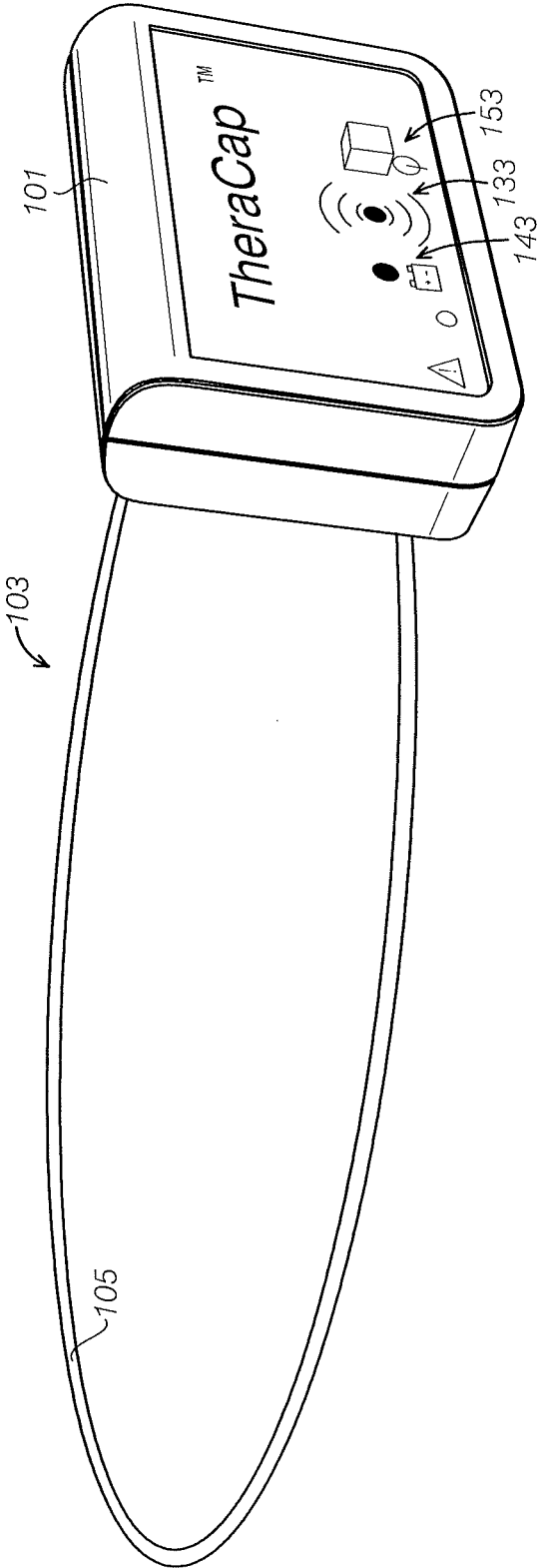

FIG. 1A

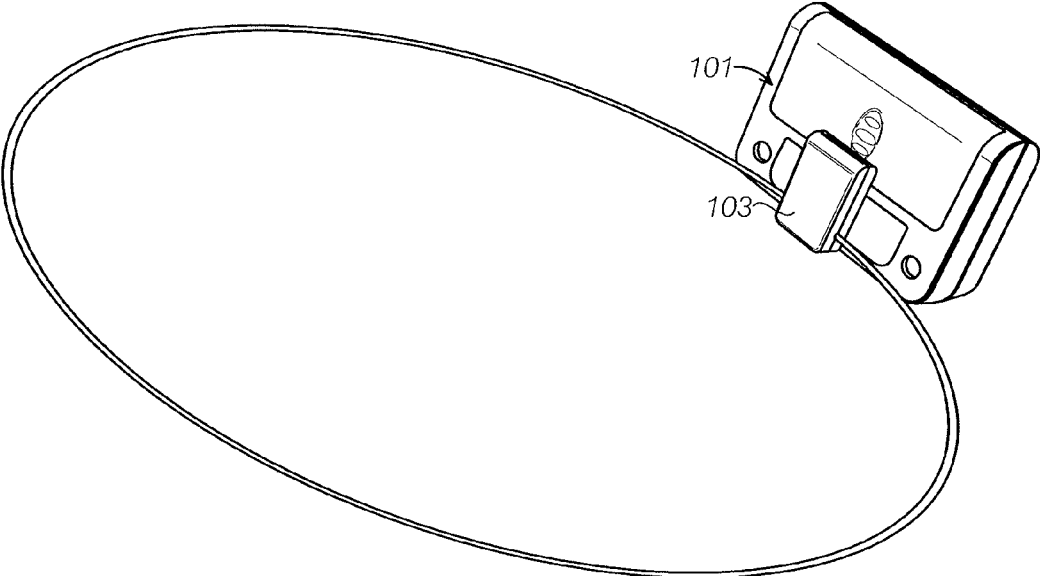

FIG. 1B

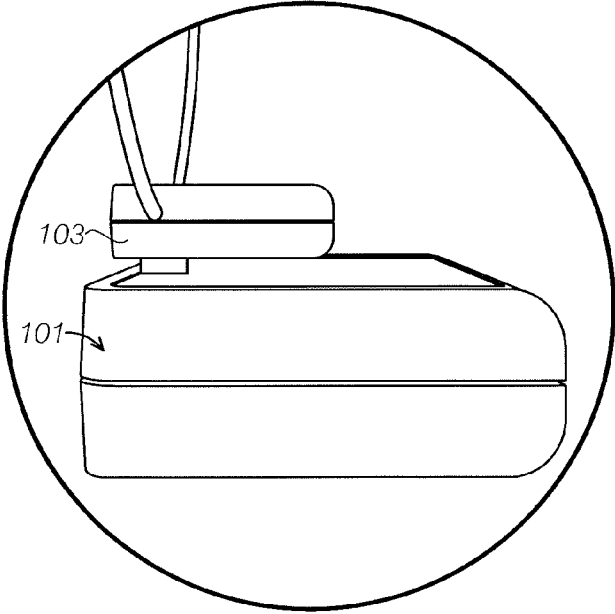

FIG. 1C

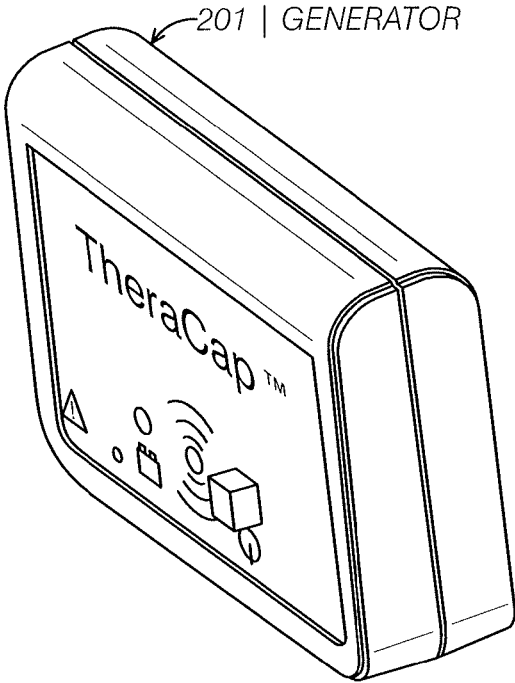

FIG. 2A

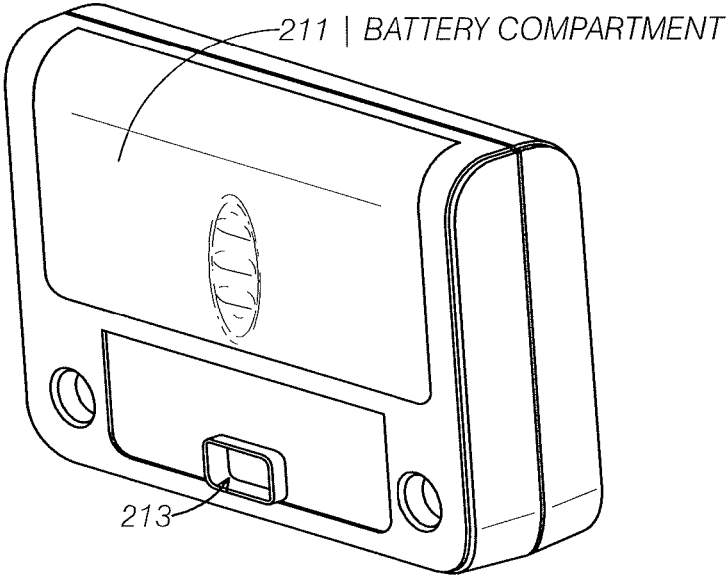

FIG. 2B

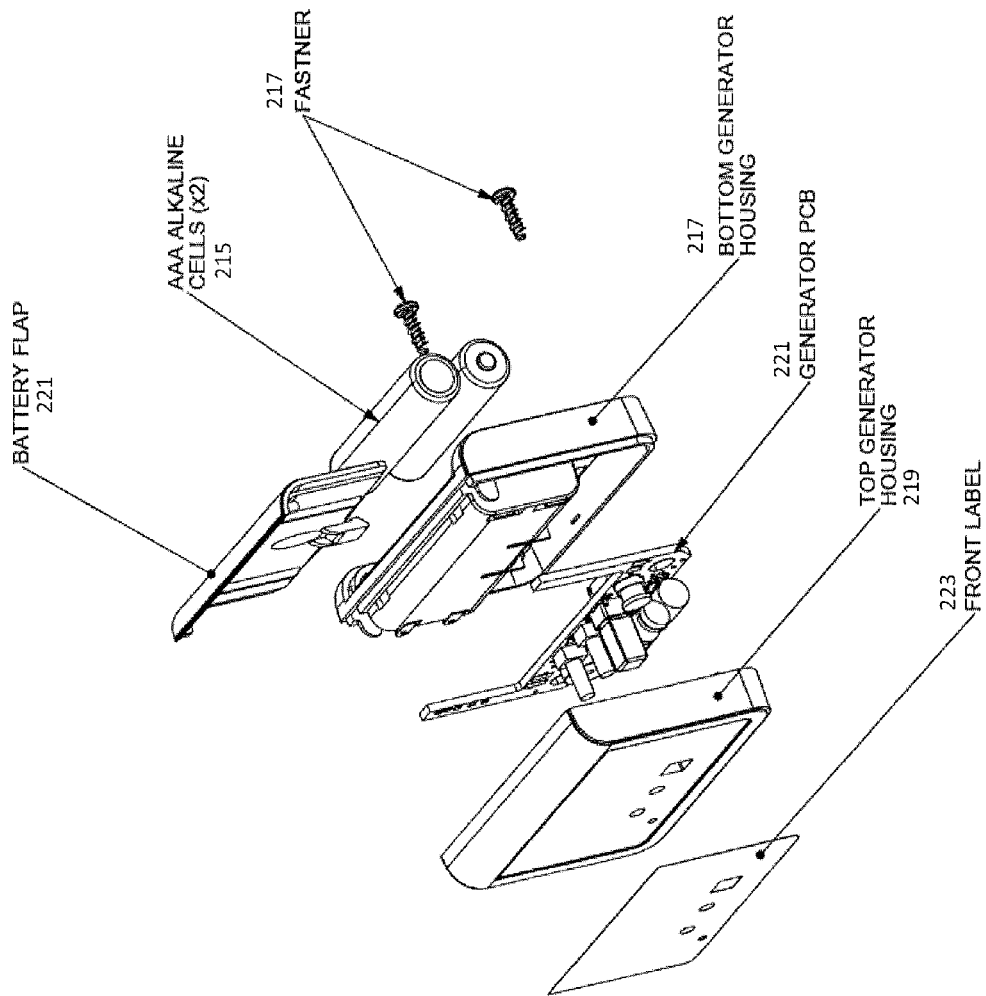

FIG. 2C

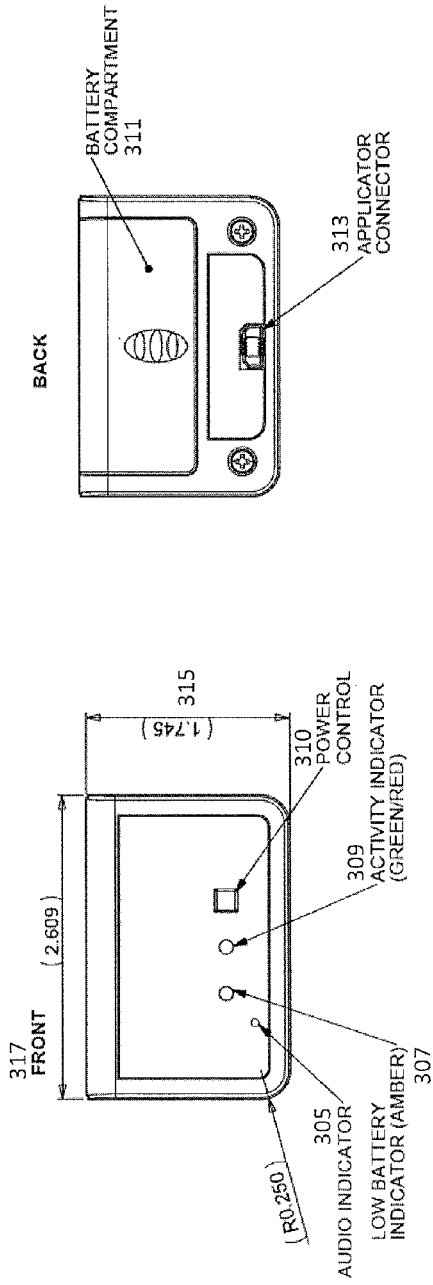

FIG. 3A

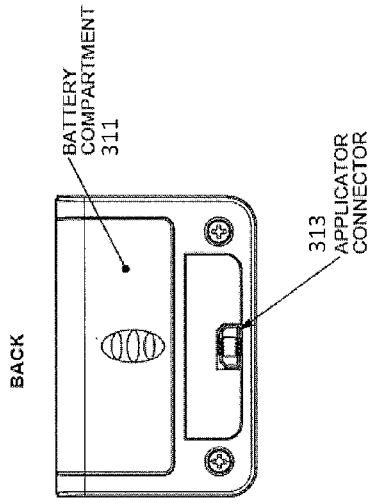

FIG. 3B

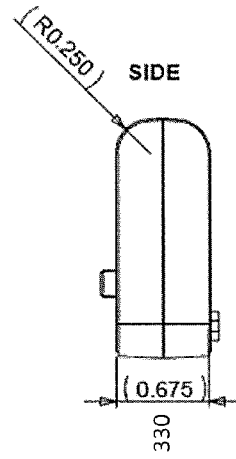

FIG. 3D

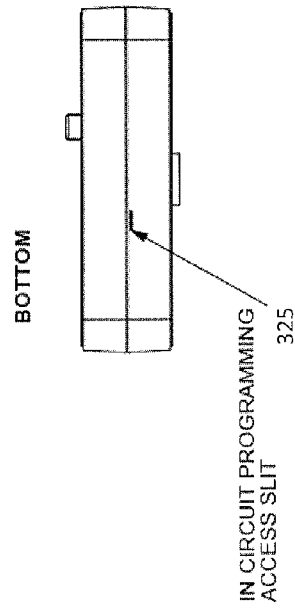

FIG. 3C

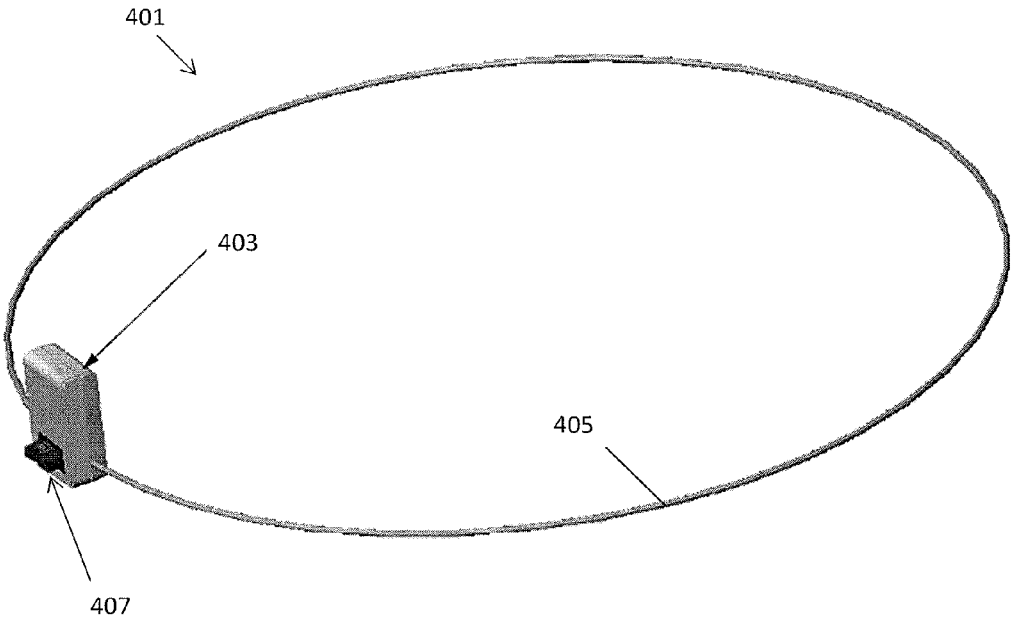

FIG. 4A

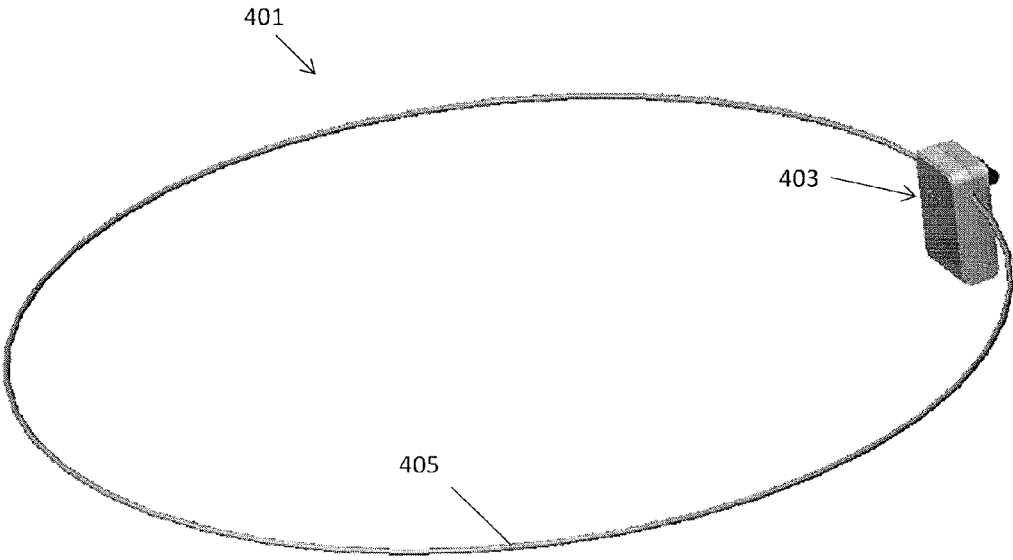

FIG. 4B

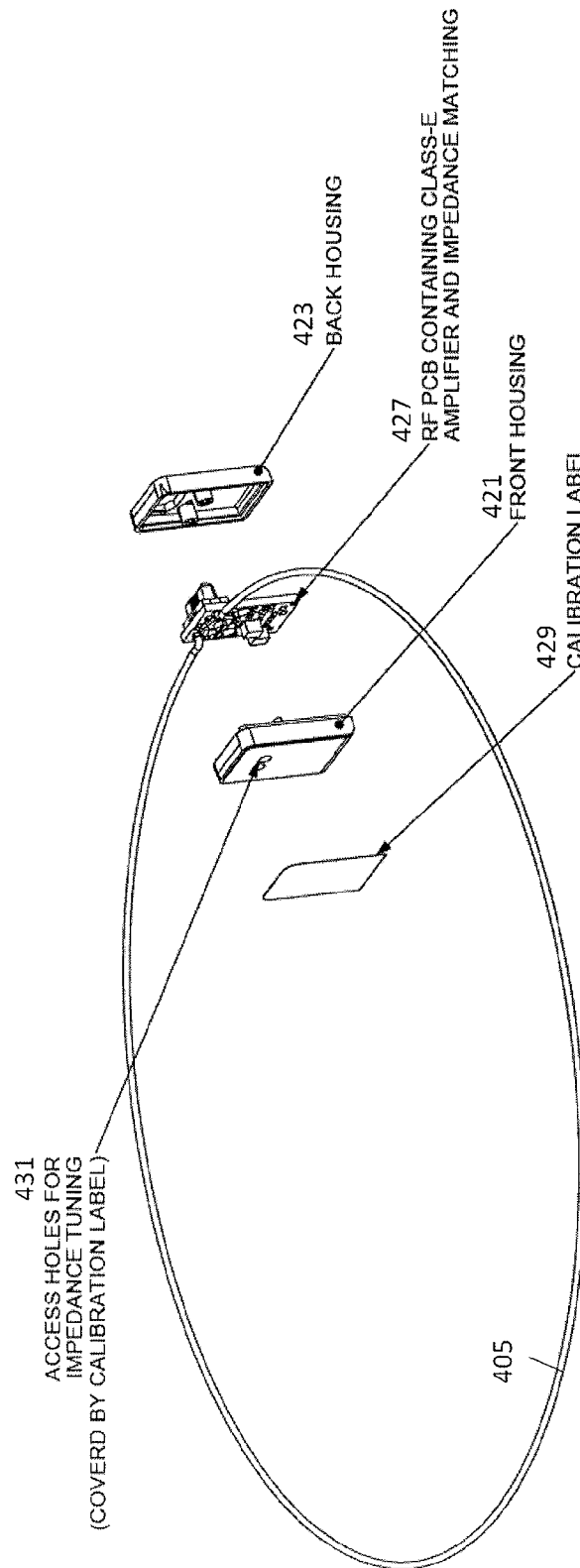

FIG. 4C



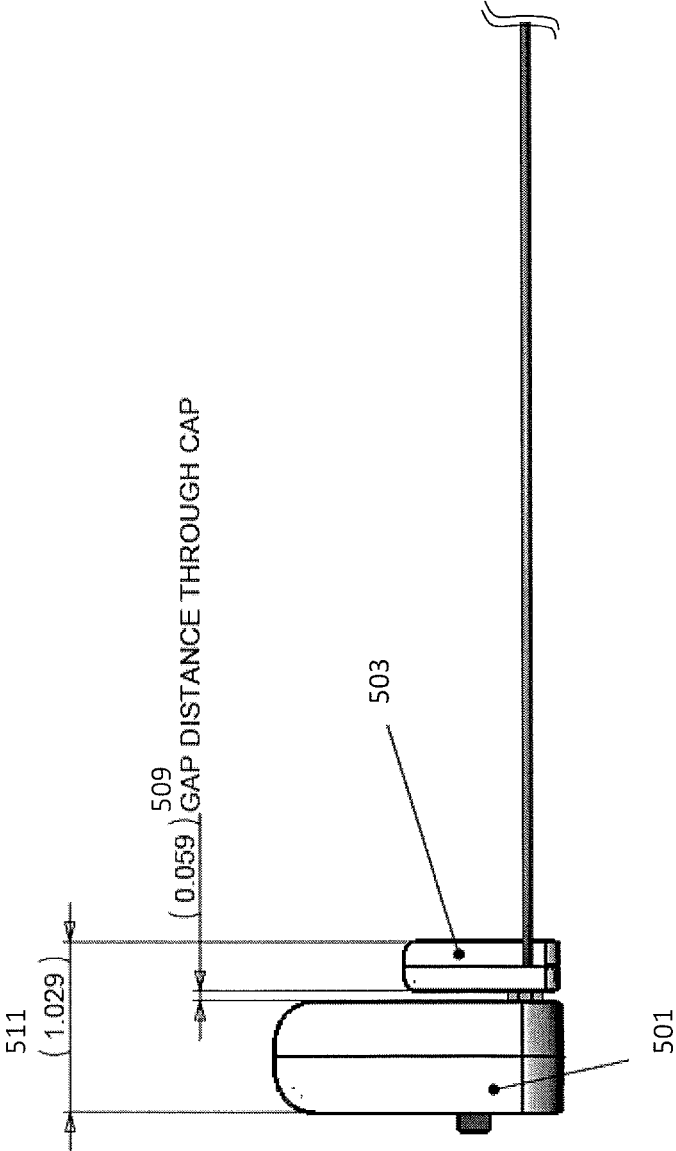

FIG. 5A

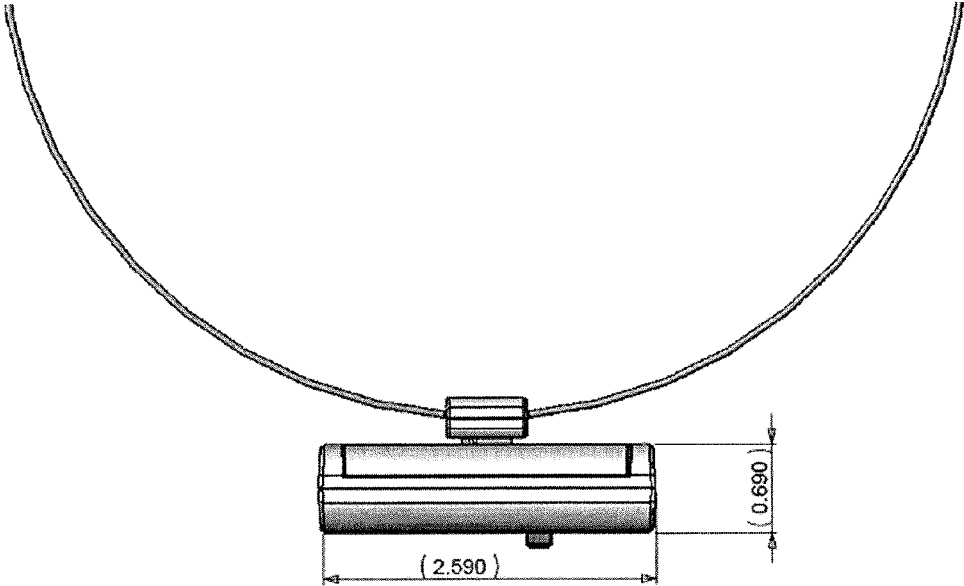

FIG. 5B

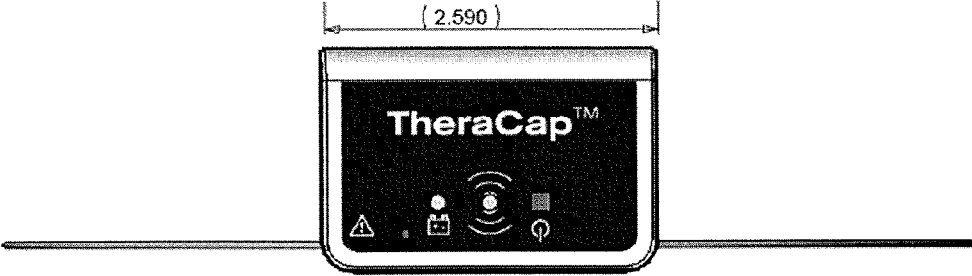

FIG. 5C

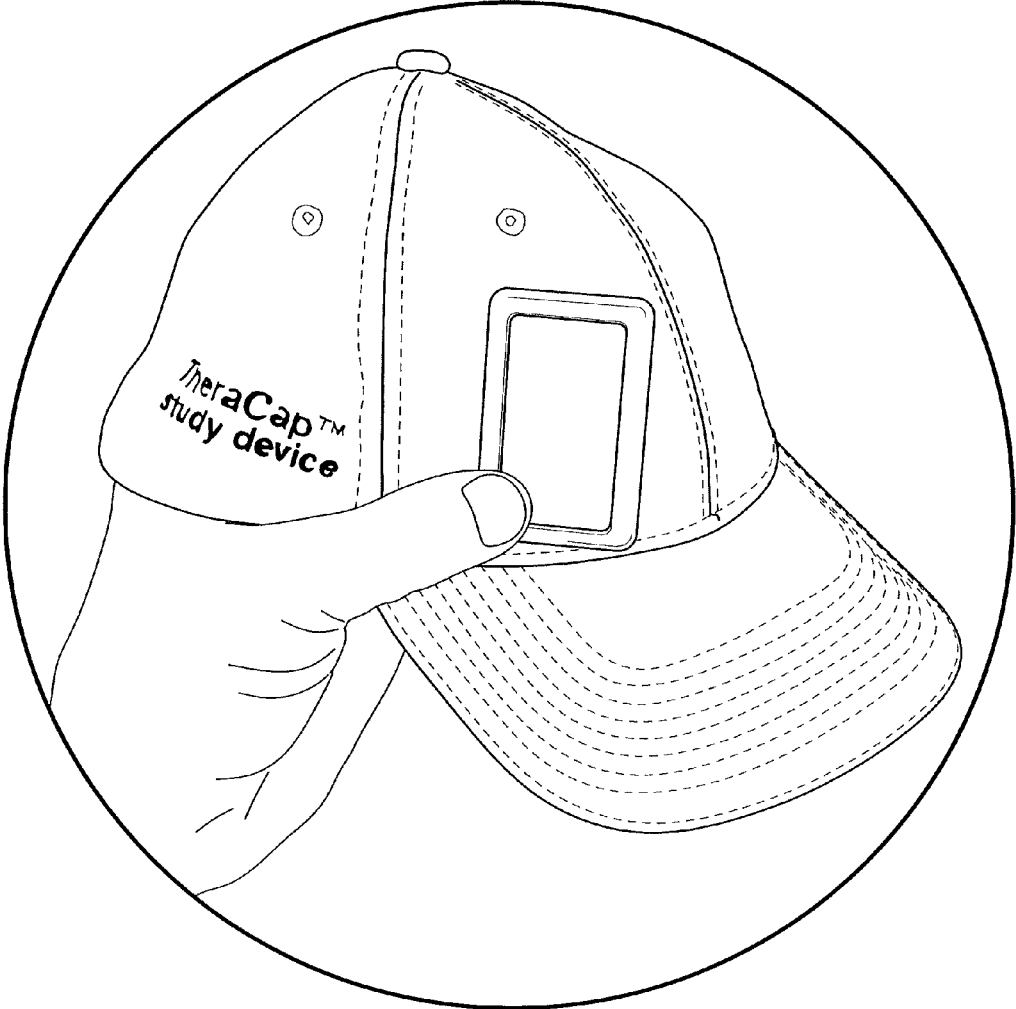

FIG. 6

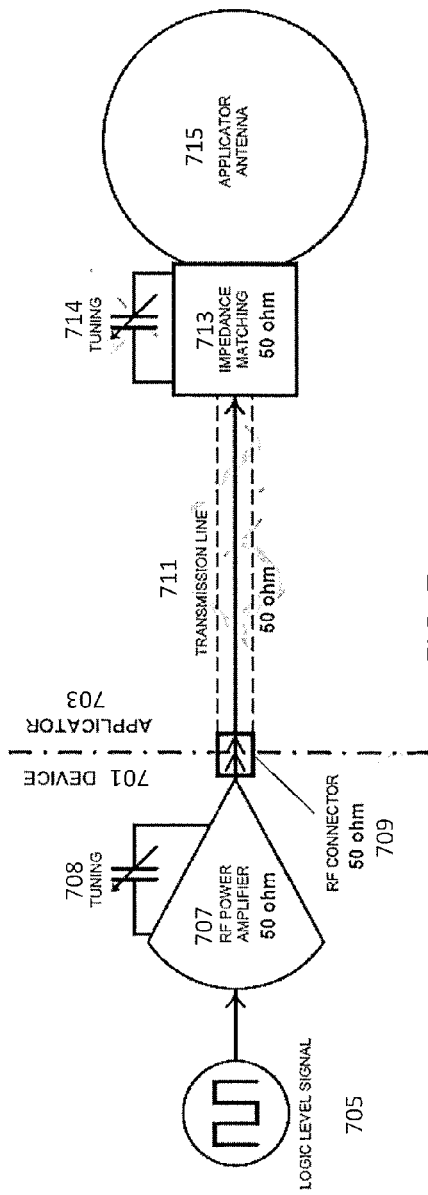

FIG. 7  
(Prior art)

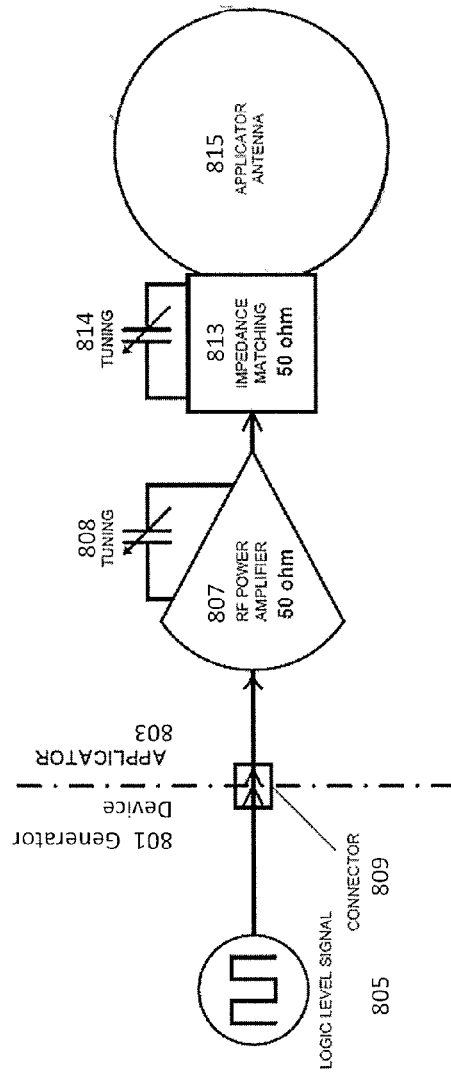

FIG. 8

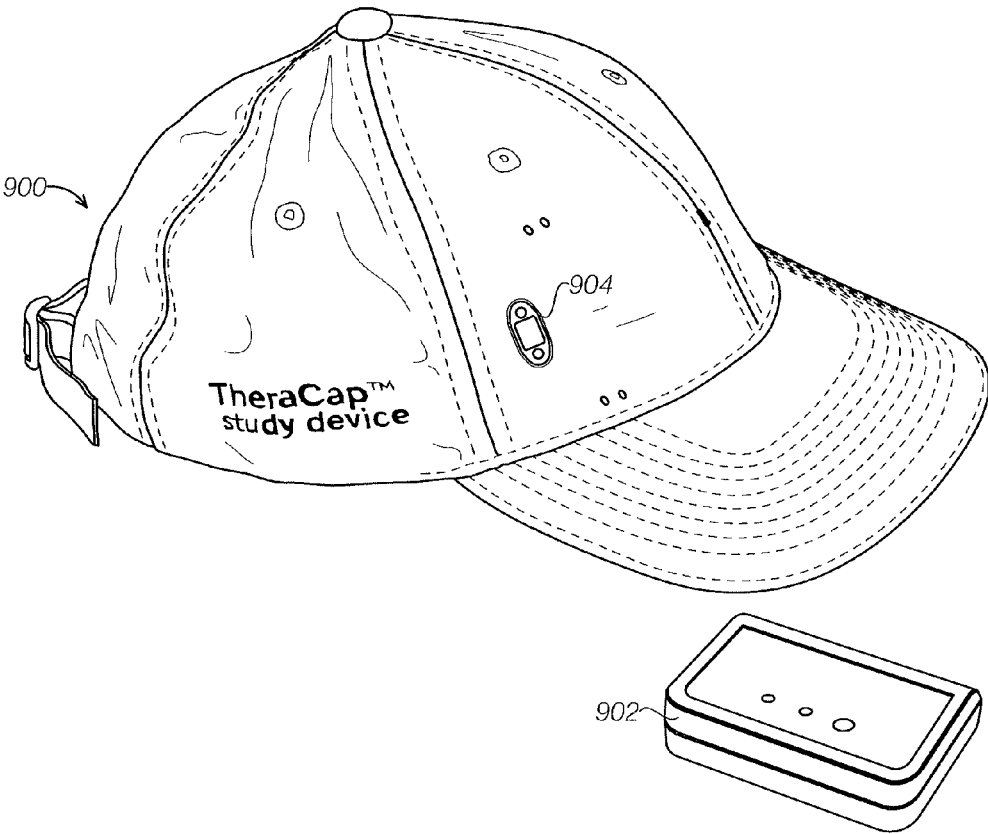

FIG. 9

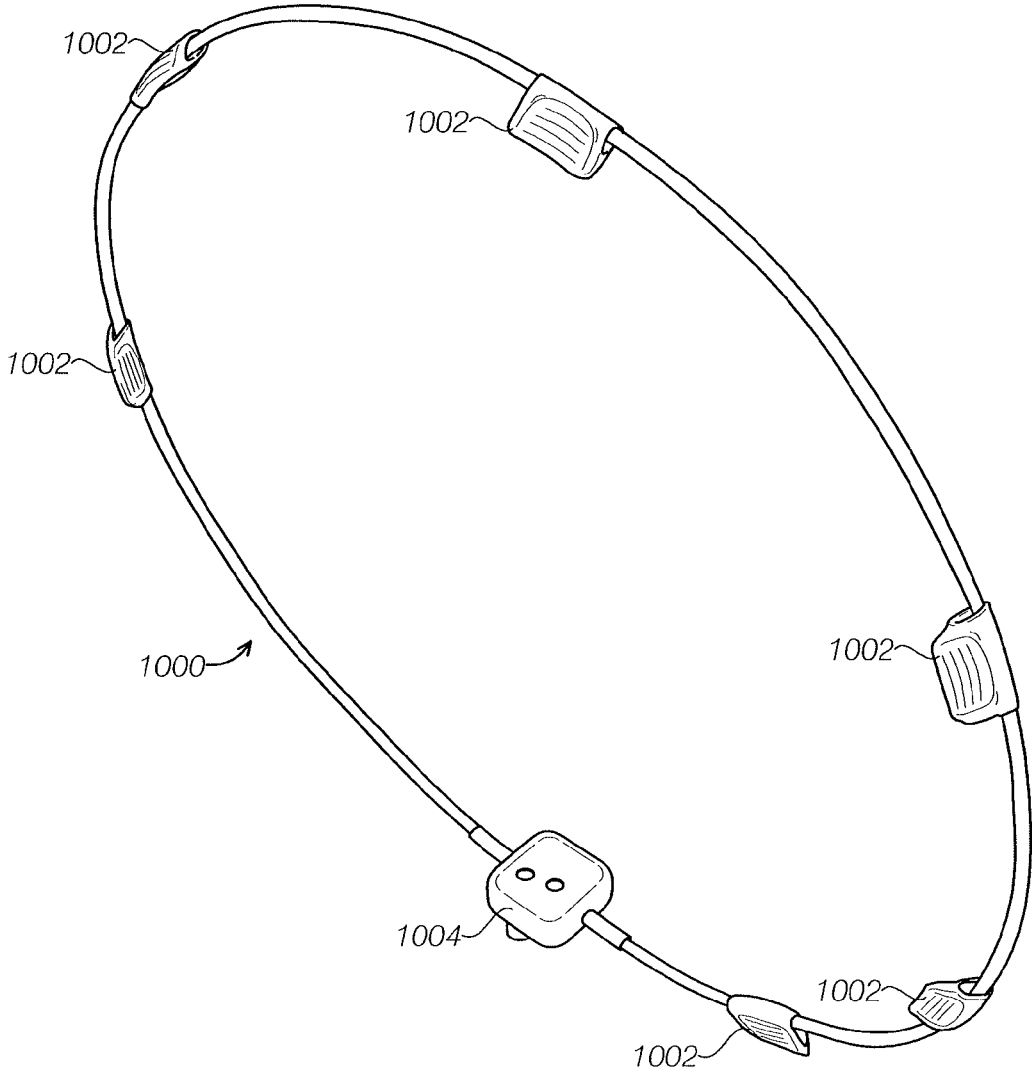

FIG. 10

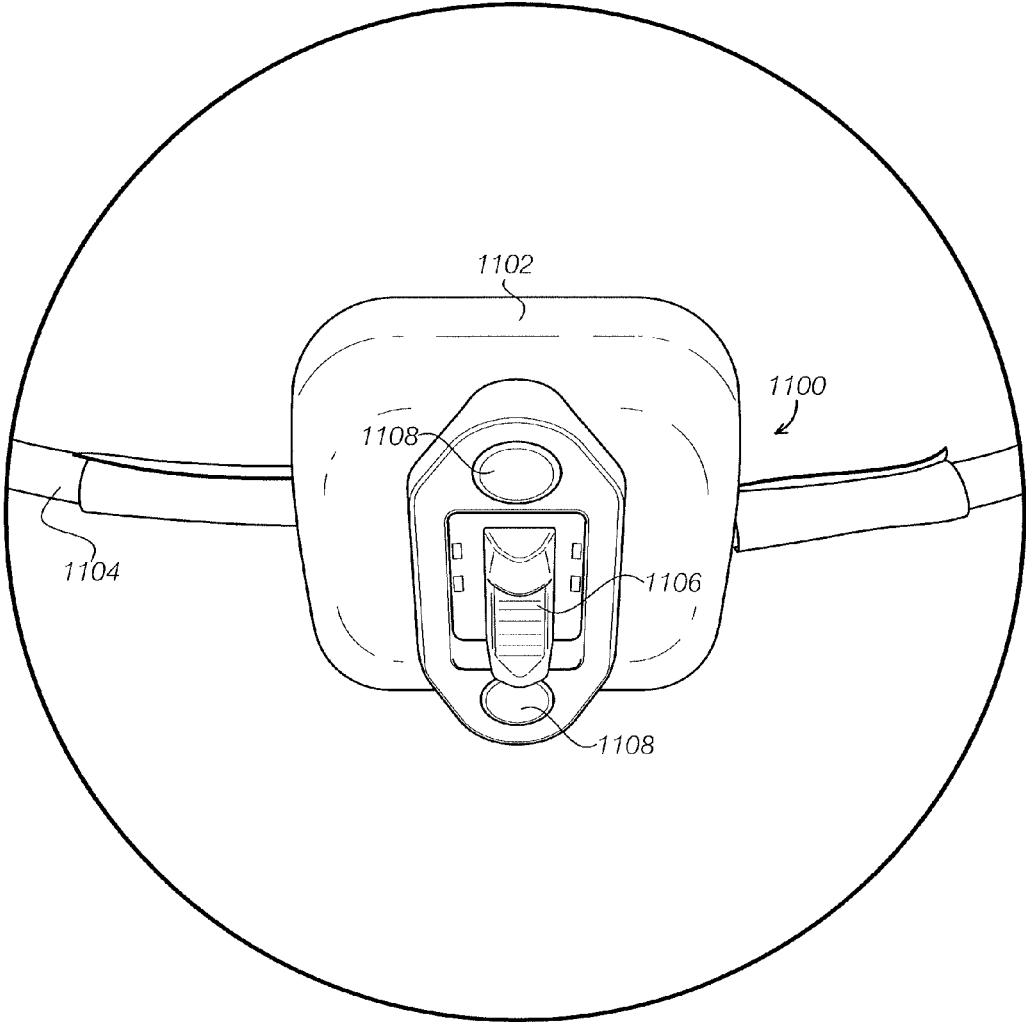

FIG. 11A

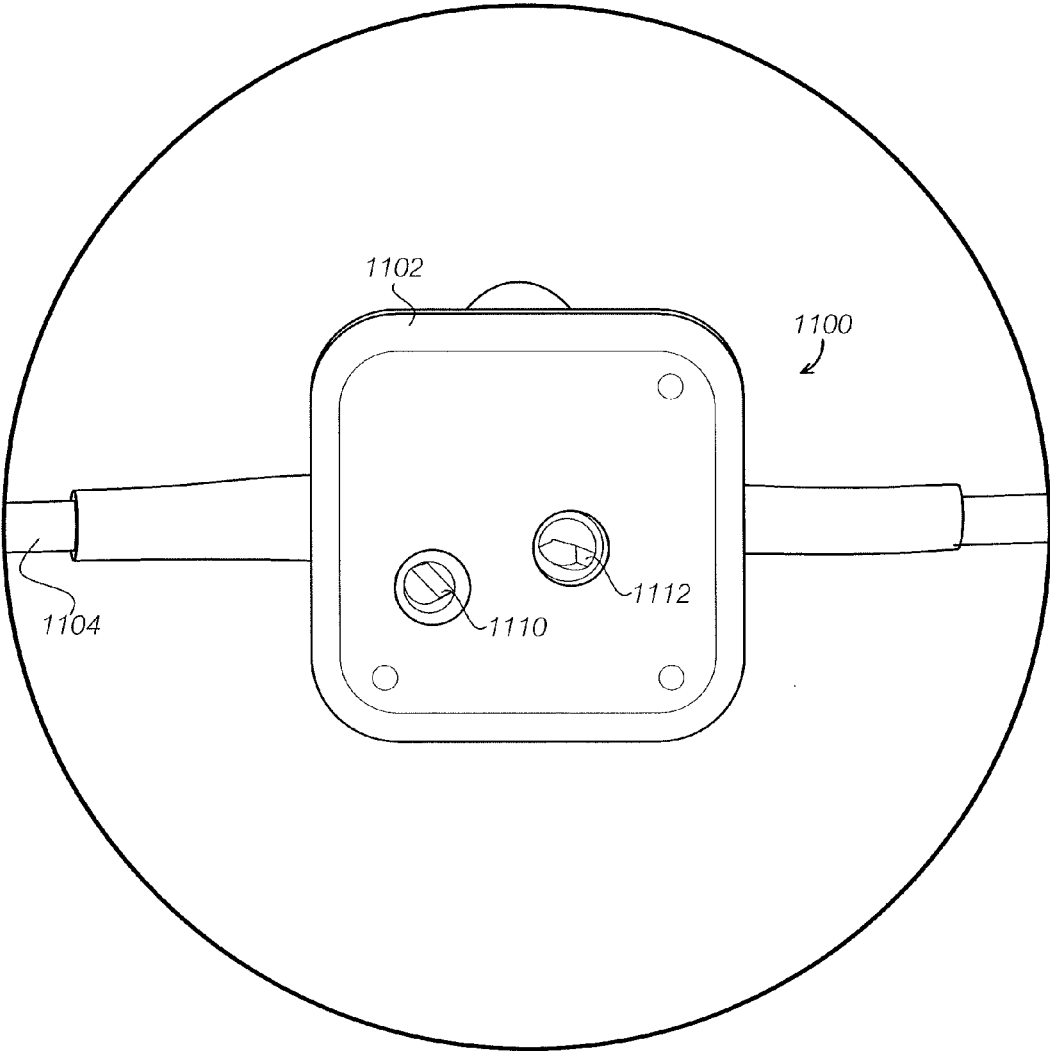

FIG. 11B



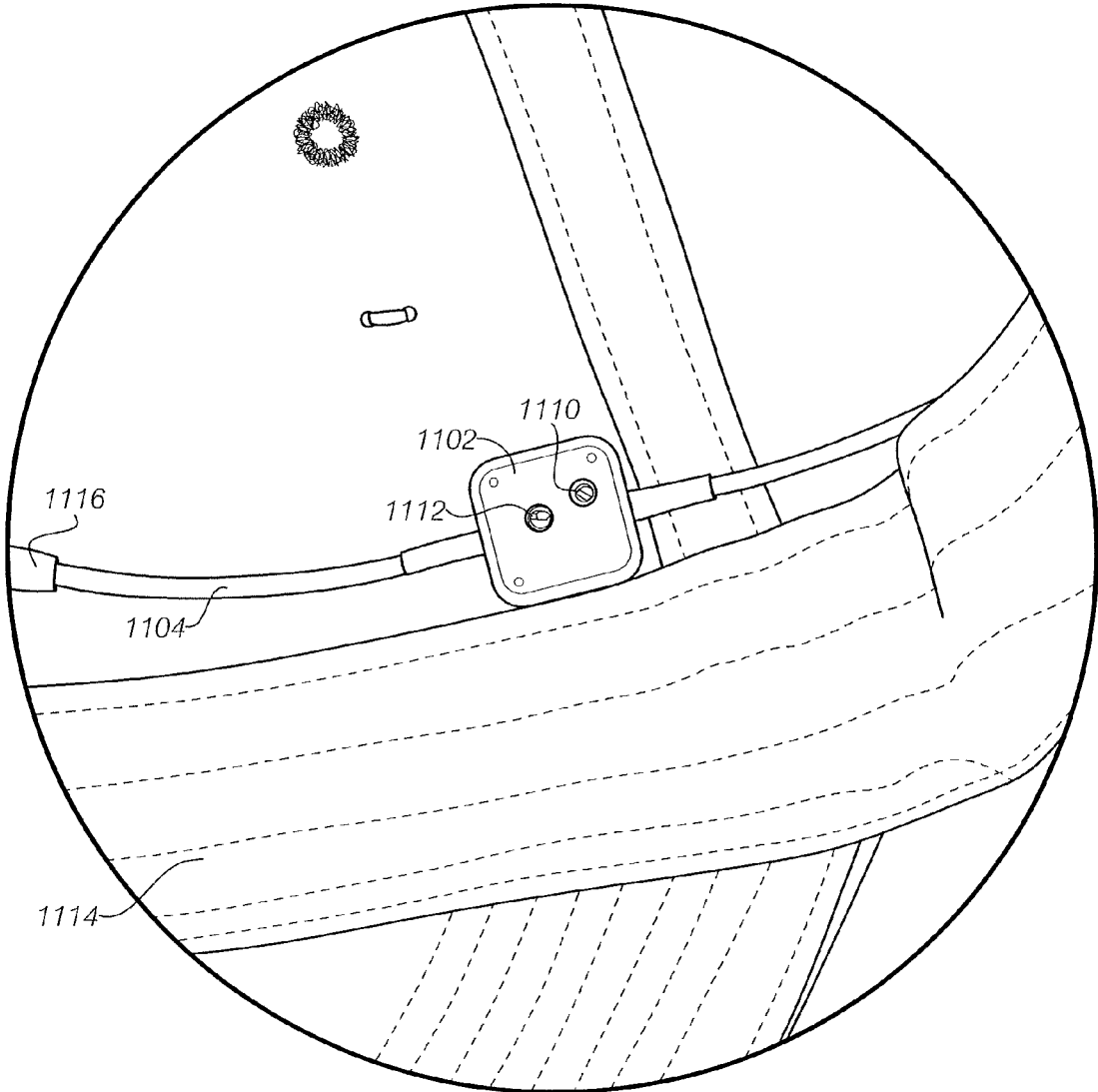

FIG. 11C

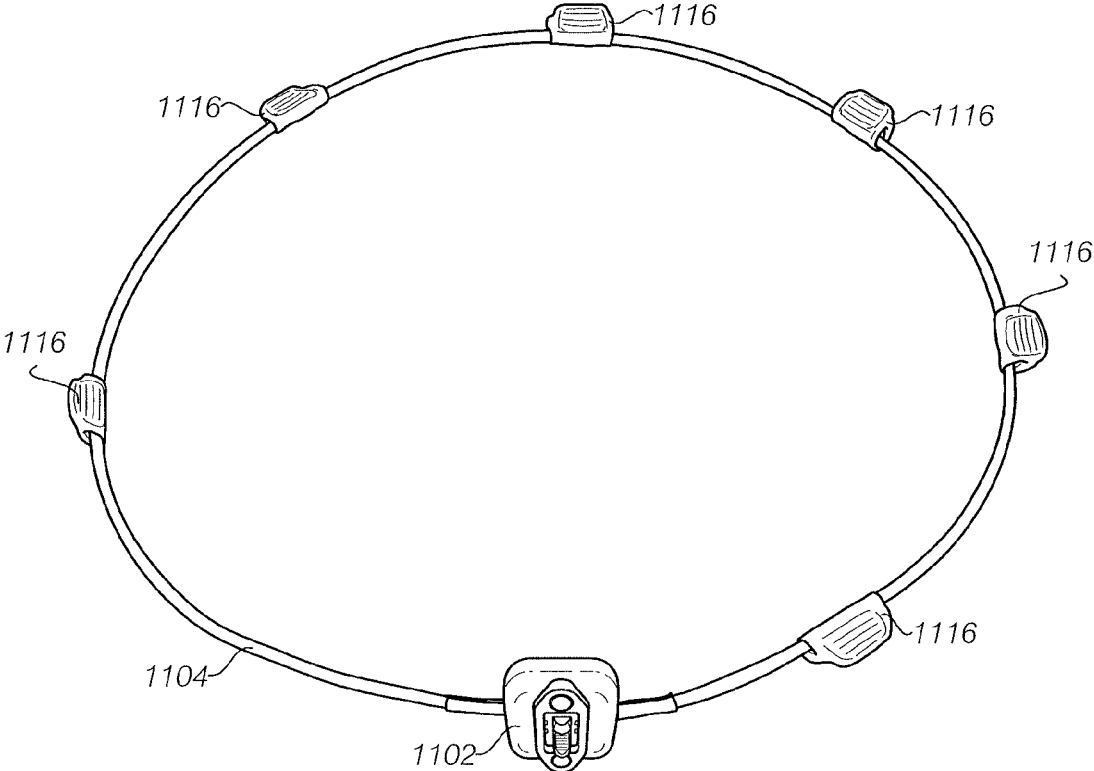

FIG. 11D

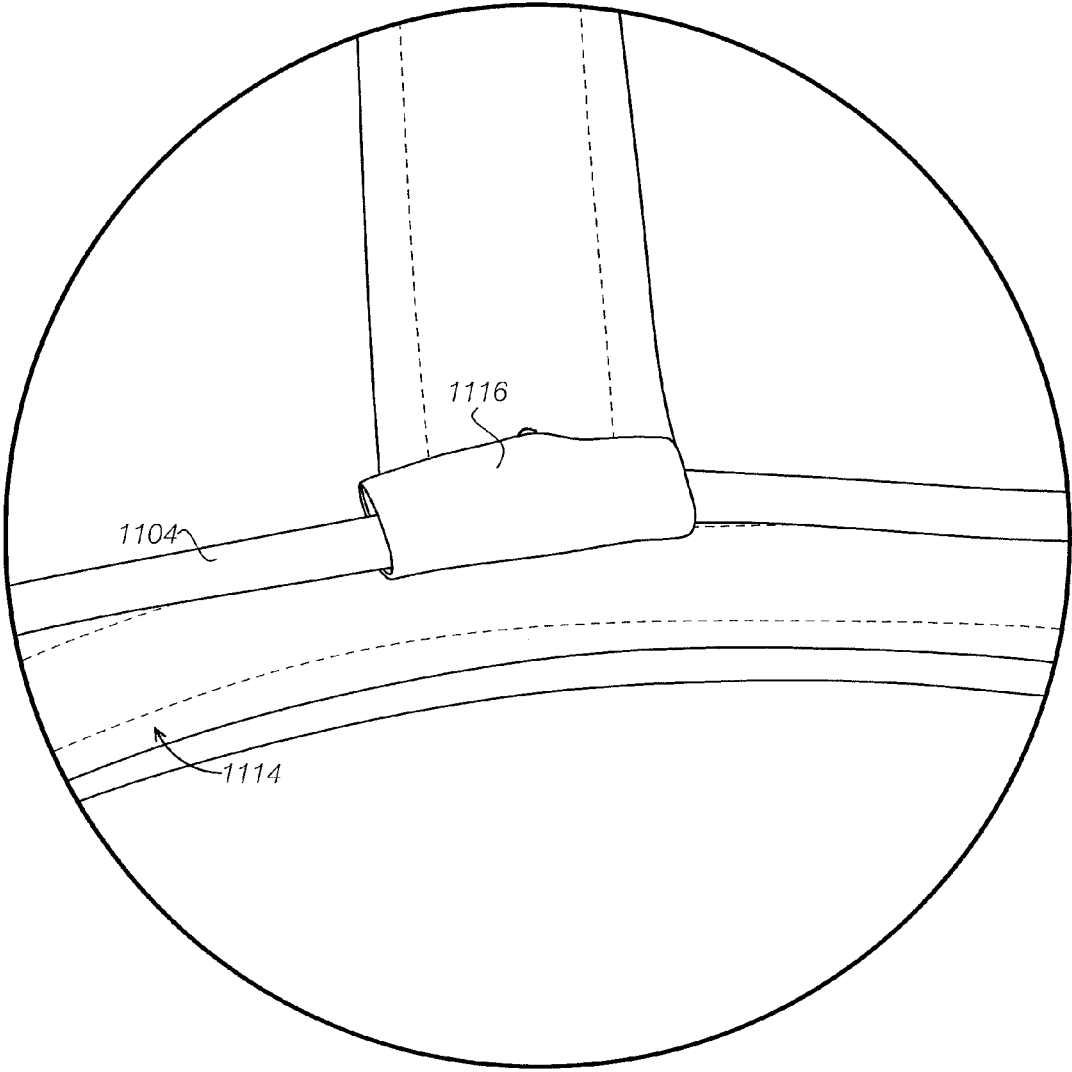

FIG. 11E

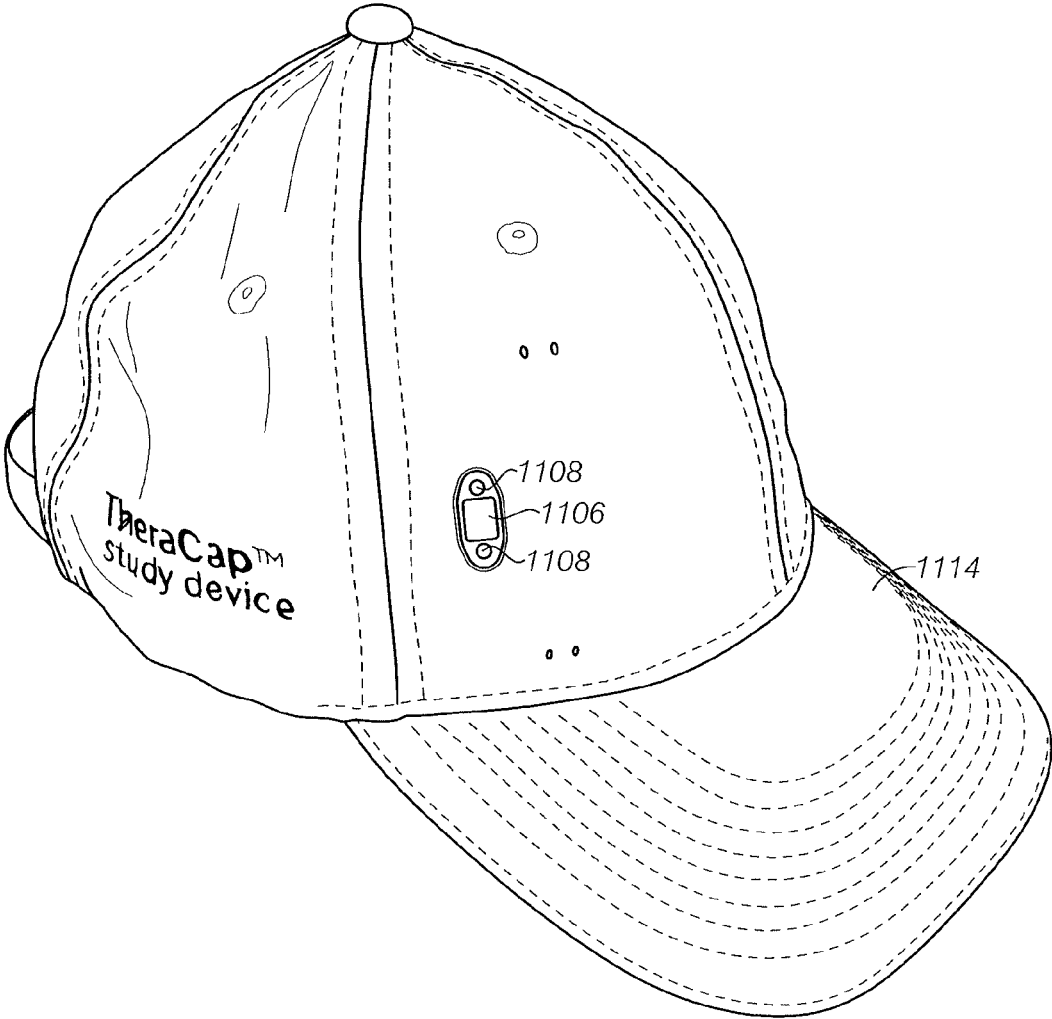

FIG. 12A

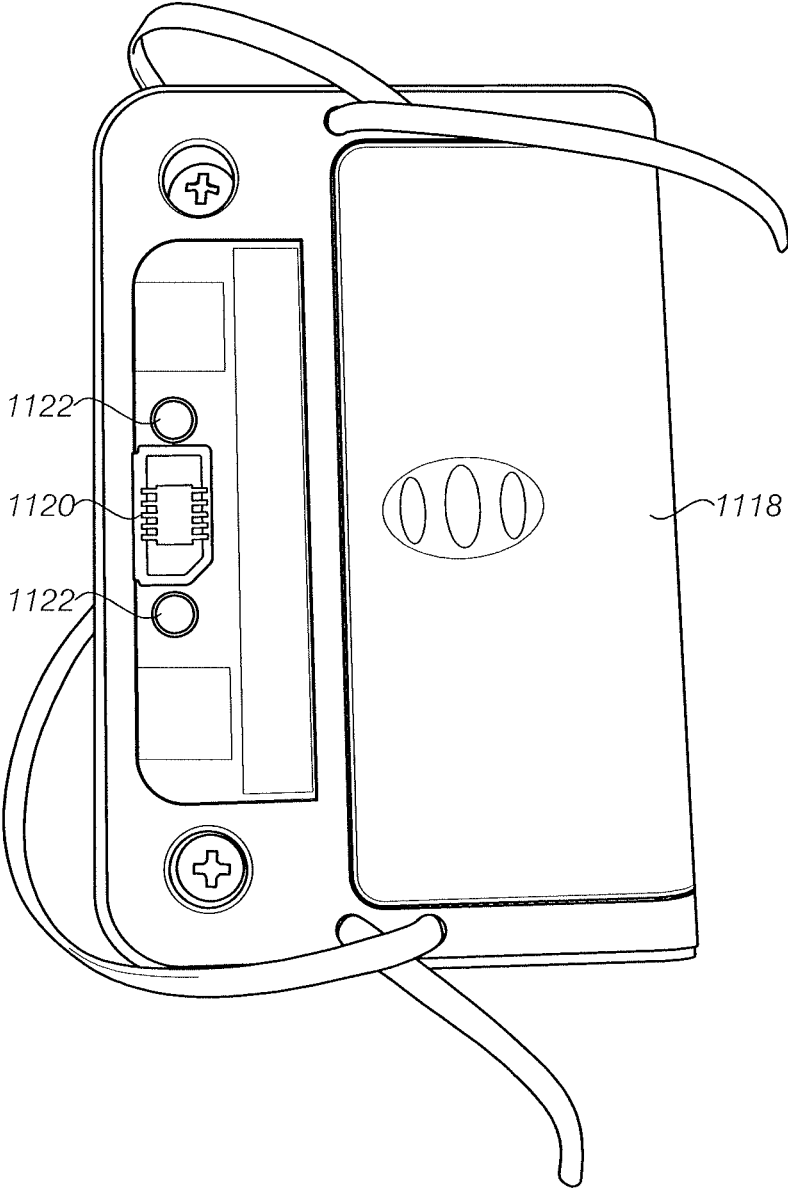

FIG. 12B

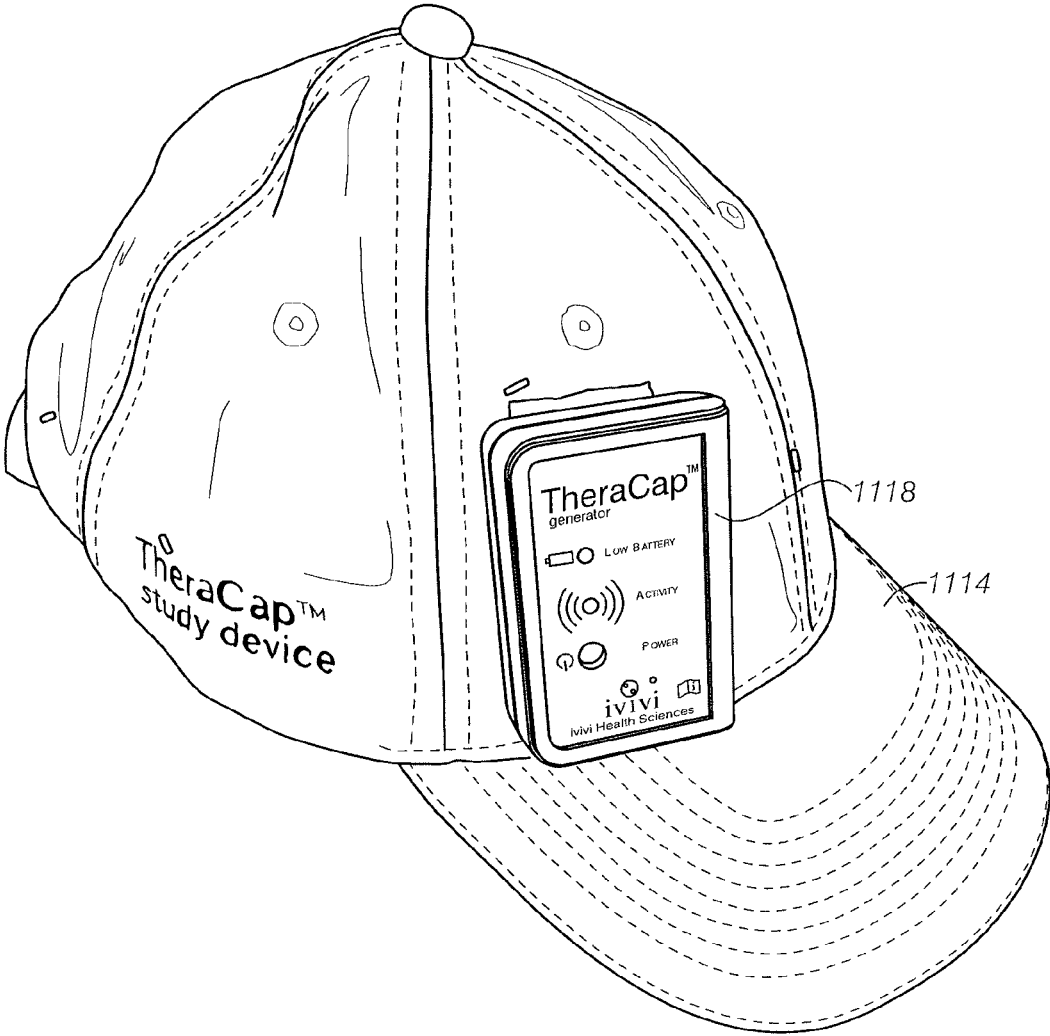

FIG. 12C

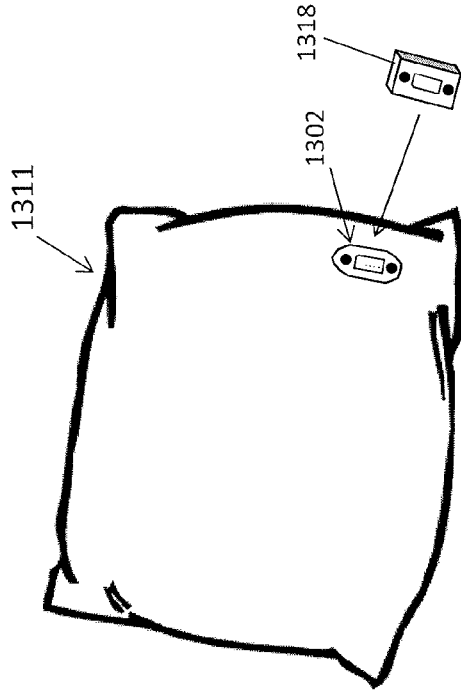

FIG. 13B

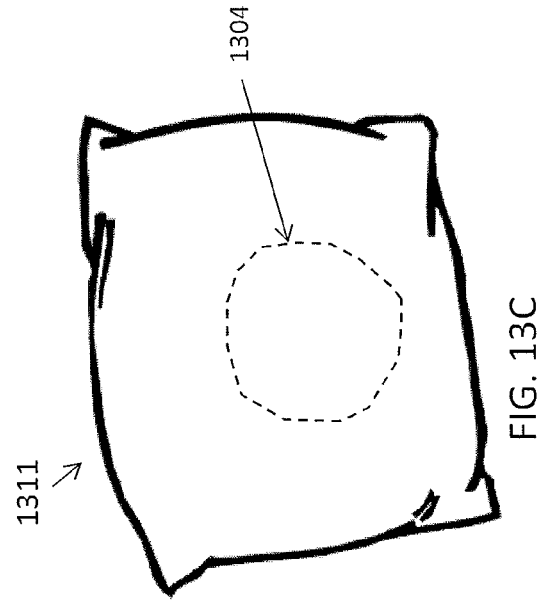

FIG. 13C

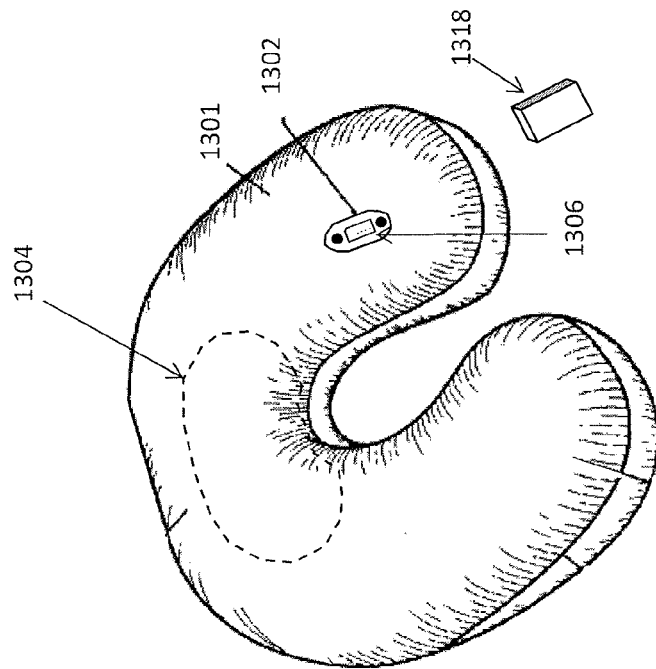

FIG. 13A

## TWO-PART PULSED ELECTROMAGNETIC FIELD APPLICATOR FOR APPLICATION OF THERAPEUTIC ENERGY

### CROSS REFERENCE TO RELATED APPLICATIONS

**[0001]** This patent application is a continuation of U.S. patent application Ser. No. 14/688,602, filed on Apr. 16, 2015 titled “A TWO-PART PULSED ELECTROMAGNETIC FIELD APPLICATOR FOR APPLICATION OF THERAPEUTIC ENERGY,” Publication No. US-2015-0297910-A1, which claims priority to U.S. Provisional Patent Application No. 61/980,433, filed on Apr. 16, 2014, titled “A TWO-PART PULSED ELECTROMAGNETIC FIELD APPLICATOR FOR APPLICATION OF THERAPEUTIC ENERGY,” and U.S. Provisional Patent Application No. 62/086,987, filed on Dec. 3, 2014, titled “A TWO-PART PULSED ELECTROMAGNETIC FIELD APPLICATOR FOR APPLICATION OF THERAPEUTIC ENERGY,” each of these applications is herein incorporated by reference in its entirety.

### INCORPORATION BY REFERENCE

**[0002]** All publications and patent applications mentioned in this specification are herein incorporated by reference in their entirety to the same extent as if each individual publication or patent application was specifically and individually indicated to be incorporated by reference.

### FIELD

**[0003]** Described herein are pulsed electromagnetic field (PEMF) treatment apparatuses including one or more integrated coils and methods for making and for using PEMF apparatuses for the therapeutic treatment of subjects. More particularly described herein are non-invasive PEMF applicators having two parts: a PEMF generator component, including a power supply and a signal generator, that is adapted to removably couple with a wearable applicator that includes a matched RF power amplifier and impedance matched loop antenna.

### BACKGROUND

**[0004]** Weak, non-thermal electromagnetic fields (“EMF”) can result in physiologically meaningful in vivo and in vitro bioeffects. See, e.g., U.S. patents and pending applications: U.S. Pat. No. 5,370,680, U.S. Pat. No. 5,584,863, U.S. Pat. No. 5,723,001, U.S. Pat. No. 7,740,574, U.S. Pat. No. 7,744,524, U.S. Pat. No. 7,758,490, U.S. Pat. No. 7,896,797, U.S. Pat. No. 8,343,027, U.S. Pat. No. 8,415,123; U.S. 2010-0210893, U.S. 2010-0222631, U.S. 2013-0274540, U.S. 2014-0046115, U.S. 2014-0046117, U.S. 2011-0207989, U.S. 2012-0116149, and U.S. 2012-0089201, each of which describes PEMF applicator and methods of using them. Each of these publications is herein incorporated by reference in its entirety.

**[0005]** Time-varying electromagnetic fields, comprising EMF, ranging from several Hertz to about 100 GHz, have been found to be clinically beneficial when used as a therapy for reducing pain levels for patients undergoing surgical procedures, promoting healing in patients with chronic wounds or bone fractures, and reducing inflammation or edema in injuries (e.g. sprains). Presently several EMF devices constitute the standard armamentarium of orthope-

dic clinical practice for treatment of difficult to heal fractures. The success rate for these devices has been very high. The database for this indication is large enough to enable its recommended use as a safe, non-surgical, non-invasive alternative to a first bone graft. Additional clinical indications for these technologies have been reported in double blind studies for treatment of avascular necrosis, tendinitis, osteoarthritis, wound repair, blood circulation and pain from arthritis as well as other musculoskeletal injuries.

**[0006]** In addition, cellular studies have addressed effects of weak electromagnetic fields on both signal transduction pathways and growth factor synthesis. It has been shown that EMF stimulates secretion of growth factors after a short, trigger-like duration. Ion/ligand binding processes at intracellular buffers attached to the cell membrane are an initial EMF target pathway structure. The clinical relevance to treatments, for example, of bone repair, is up-regulation such as modulation, of growth factor production as part of normal molecular regulation of bone repair. Cellular level studies have shown effects on calcium ion transport, cell proliferation, Insulin Growth Factor (“IGF-II”) release, and IGF-II receptor expression in osteoblasts. Effects on Insulin Growth Factor-I (“IGF-I”) and IGF-II have also been demonstrated in rat fracture callus. Pulsed electromagnetic fields (“PEMF”) have also been shown to have an effect on transforming growth factor beta (“TGF- $\beta$ ”) messenger RNA (“mRNA”) in a bone induction model in a rat. Studies have also demonstrated up-regulation of TGF- $\beta$  mRNA by PEMF in human osteoblast-like cell line designated MG-63, wherein there were increases in TGF- $\beta$ 1, collagen, and osteocalcin synthesis. PEMF stimulated an increase in TGF- $\beta$ 1 in both hypertrophic and atrophic cells from human non-union tissue.

**[0007]** Further studies demonstrated an increase in both TGF- $\beta$ 1 mRNA and protein in osteoblast cultures resulting from a direct effect of EMF on a calcium/calmodulin-dependent pathway. Cartilage cell studies have shown similar increases in TGF- $\beta$ 1 mRNA and protein synthesis from EMF, demonstrating a therapeutic application to joint repair. U.S. Pat. No. 4,315,503 (1982) to Ryaby, U.S. Pat. No. 7,468,264 (2008) to Brighton and U.S. Pat. Nos. 5,723,001 (1998) and 7,744,524 (2010) to Pilla typify the research conducted in this field.

**[0008]** There are currently two types of applicators adapted for applying PEMF. For example, integrated applicators in which the power supply and signal conditioner is integrated into the applicator have been proposed, including those discussed above. Such applicator may be lightweight and wearable, however the operation of the device may be limited by the power supply. Further, although fixedly coupling the signal generator and power amplifier to the antenna delivering the PEMF to the body simplifies the impedance matching between the applicator (antenna) and the power source, the result is somewhat inflexible in operation.

**[0009]** Modular applicators have also been designed, in which the power supply, including the power/signal amplification and waveform/signal generator is separate from the applicator, and may be connected by a cord or wire to one or more applicator. The applicators may be disposable, and typically include only the applicator (e.g., antenna) and connector. This arrangement, while conceptually simple, has various drawbacks. For example, to achieve maximum efficiencies, the impedance of all components of the radio



frequency (RF) power pathway must have the same impedance. Thus, the transmission lines and RF connector must have fixed characteristic impedance values. The RF power amplifier and applicator antenna must be impedance matched (e.g., by impedance adjusting circuits) to match the impedance of the cord/transmission line. This arrangement has significant drawbacks for low-power devices. In order to achieve sufficient field strength, the antenna impedance matching circuit must have a high quality factor (“Q-factor”) with a very narrow bandwidth. With the normal component variability of high Q-factor components, carrier frequency drift, and tuning variability due to mechanical vibrations, the output field strength may be severely affected, particularly between different applicators connected to the same power supply. Thus, modular PEMF applicators that include separate applicators and power supplies typically require a somewhat complicated (and as a result, large and unwieldy or heavy) power supply portion.

[0010] Accordingly, described herein are PEMF applicator systems that may address the need for electromagnetic therapy devices (e.g., PEMF devices) that are simple, lightweight (and wearable) and include a removable/re-attachable signal generator that can couple with one (or more) antenna applicators.

#### SUMMARY OF THE DISCLOSURE

[0011] Described herein are two-part (e.g., modular) PEMF applicator apparatuses and methods of making and using them. In particular, described herein are PEMF applicators that may include: a generator module that includes a power supply (e.g., battery, capacitive power supply, etc.) and signal conditioning (e.g., pulse generator), including timing and control circuitry, but that does not include power amplification or tuning (e.g. impedance matching); and an applicator component that includes power amplification and impedance matching between the amplifier(s) and the delivery antenna(s). The generator and applicator components may be removably coupleable to each other and the combined generator and applicator can be worn or supported on a subject’s body as a lightweight component or part of a delivery component such as a garment (hat, clothing, etc.) or bandage (brace, cast, etc.).

[0012] In general, the generator component may include a power supply such as a battery or set of batteries (E.g., AAA alkaline batteries), and may include a processor for preparing the signals (including waveform shaping and timing) to be delivered. The generator component may include a housing that is adapted to mate with an applicator housing that is attached or includes the applicator. Thus, the generator may include a releasable coupling that mates with a coupling on the applicator component to secure the two together. The generator may also be adapted to receive and/or transmit information (e.g., to a microprocessor for control, and/or recording or storing information). The generator may also include one or more indicators for indicating the status of the apparatus (e.g., on/off, delivering PEMF, low power, etc.). The applicator may also include a processor (microprocessor, CPU, etc.) which be used to control operation of the device, including shaping and/or timing of the PEMF waveforms delivered by the applicator.

[0013] In general, the applicator unit may include a complementary coupler for attaching to the generator component. For example, the applicator may include a plug (male, female or hybrid) that couples with the generator. The

applicator also includes one or more antenna. In particular, the applicator may include a loop antenna formed of a loop of wire (e.g., having a diameter of 5 inches, 6 inches, 7 inches, 8 inches, 9 inches, 10 inches, 11 inches, 12 inches, etc.). The wire antenna may be flexible/shapeable, and may be positioned over or adjacent to the subject. In some variations the antenna may be integrated into a holder such as a garment or brace. For example, the applicator (including the antenna) may be adapted to fit into a hat or cap to be worn on a subject’s head.

[0014] The applicator component also typically includes a power amplifier for amplification of signals received by the RF generator of the generator module. The power amplifier may be tuned (automatically or manually) and is integrated into the applicator module/component with the antenna and an impedance match component that matches the impedance of the antenna of the applicator with the power amplifier.

[0015] Additional details are provided below including by reference to the figures.

#### BRIEF DESCRIPTION OF THE DRAWINGS

[0016] FIG. 1A shows a front perspective view of a two-part therapeutic PEMF apparatus including a generator unit that is coupled to an antenna applicator unit.

[0017] FIG. 1B shows a back perspective view of the apparatus of FIG. 1A.

[0018] FIG. 1C shows an enlarged view of the coupling between the generator unit and the applicator unit of the PEMF apparatus shown in FIGS. 1A and 1B.

[0019] FIG. 2A is a front perspective view of a generator unit of a therapeutic PEMF apparatus.

[0020] FIG. 2B is a back perspective view of the generator unit of FIG. 2A.

[0021] FIG. 2C is an exploded view of the generator unit shown in FIGS. 6A-6D.

[0022] FIG. 3A is an exemplary front view of a generator unit of a two-part therapeutic PEMF apparatus, including exemplary dimensions.

[0023] FIG. 3B shows a back view of the generator unit shown in FIG. 3A.

[0024] FIGS. 3C and 3D illustrate bottom and side views of the generator unit shown in FIG. 3A.

[0025] FIG. 4A is a front perspective view of the applicator (or antenna) unit.

[0026] FIG. 4B is a back perspective view of the applicator unit of FIG. 4A.

[0027] FIG. 4C shows an exploded view of the applicator unit of FIGS. 4A and 4B.

[0028] FIG. 5A shows a side view, including exemplary dimensions, of a PEMF apparatus including a generator module and an applicator module. The loop antenna is partially cut off in this figure.

[0029] FIG. 5B is a partial top view, including exemplary dimensions, of the PEMF apparatus of FIG. 5A. The loop antenna is partially cut off in this figure.

[0030] FIG. 5C is a partial front view, including exemplary dimensions, of the PEMF apparatus of FIGS. 5A and 5B. The loop antenna is partially cut off in this figure.

[0031] FIG. 6 illustrates one variation of a wearable two-part therapeutic PEMF apparatus configured in a baseball cap, with the applicator integrated into the cap and the generator unit configured to be attached and removed from the cap as necessary.

**[0032]** FIG. 7 schematically illustrates a modular PEMF apparatus having an integrated amplification on the generator side (prior art).

**[0033]** FIG. 8 schematically illustrates a two-part PEMF apparatus in which the RF power amplifier and impedance matching/tuning is present on the applicator unit but not on the generator unit.

**[0034]** FIG. 9 illustrates an embodiment of a wearable two-part therapeutic PEMF apparatus configured in a baseball cap with the generator not attached to the baseball cap.

**[0035]** FIG. 10 illustrates a plurality of loop antennas with applicator units in accordance with some embodiments. The loop antennas are illustrated as engaged with ring-shaped structures.

**[0036]** FIGS. 11A-11E illustrates various aspects of a two-part therapeutic PEMF apparatus.

**[0037]** FIGS. 12A-12C illustrate various aspects of a two-part therapeutic PEMF apparatus.

**[0038]** FIGS. 13A-13C illustrate another variation of a two-part therapeutic PEMF apparatus, configured as a pillow such as a travel-type pillow (FIG. 13A) or standard bed pillow (FIGS. 13B-13C).

#### DETAILED DESCRIPTION

**[0039]** Described herein are pulsed electromagnetic field (PEMF) apparatuses and methods of making and using them. In particular, described herein are two-part PEMF apparatuses that include a wearable (e.g., lightweight, small, compact form) generator unit that is adapted to releasably and replaceably mate with an applicator unit. The generator unit, which may also be referred to as a generator module, or generator component, typically includes a power source (e.g., battery, capacitor, etc.), and a controller (e.g., microcontroller and/or microprocessor) and/or waveform generator that generates the RF waveform to be applied as well as controlling the timing. The generator unit may also include a communication module (e.g., wireless module) for communicating with a separate controller/processor for transmitting data (including stimulation history) and/or receiving instructions (including waveform parameters and timing control). The generator unit may also include memory, for storing instructions and/or stimulation history.

**[0040]** In general, the generator unit may be configured so that it does not include any RF power amplification or minimal RF power amplification. Thus, the generator may also be configured so that it does not have impedance matching circuitry. The absence of power amplification and impedance matching circuitry may be an advantage. Surprisingly, the inventors have found that this allows the applicator (e.g., applicator module) to be removable from the generator without suffering radio frequency power losses due to transmission line impedance mismatching.

**[0041]** The applicator unit may also be referred to as an applicator module, antenna unit, antenna module, antenna component and/or applicator component. In general, the applicator unit includes an antenna (such as a wire loop antenna, for inductive or capacitive coupling to the subject's tissues). The antenna may be flexible and may be formed of a loop (e.g., a four inch diameter loop, a five inch diameter loop, a six inch diameter loop, a seven inch diameter loop, an eight inch diameter loop, a nine inch diameter loop, a ten inch diameter loop, an eleven inch diameter loop, a twelve inch diameter loop, etc.) of wire. The wire loop may be bendable and/or configurable, for placement over or against

the tissue. The antenna is connected to an impedance matching circuit (including, e.g., tuning circuitry) and connection to an RF power amplifier, which may also include tuning circuitry. Thus, the applicator unit may include impedance matching circuitry for connecting a radio power amplifier to an applicator by intrinsically pairing a high Q-factor impedance matching circuit to the power amplifier and the antenna. The applicator unit can include a plurality of tuning capacitors that can be tuned to provide the desired electric field and frequency. In some embodiments the applicator unit can include a plurality of ports that each allow for access to tuning capacitors in the applicator unit. The tuning capacitors can be tuned by accessing them through the ports. The tuning capacitors can be variable capacitors. A probe can be used to measure the induced voltage of the antenna. The probe can be placed around the middle of the antenna or coil. The tuning capacitors can be adjusted until the induced voltage is at a desired level. In some cases tuning is done such that the induced voltage is greater than about 120 mV.

**[0042]** The antenna can be engaged with a ring-shaped structure to hold the antenna while still allowing movement of the antenna within the ring-shaped structure and movement axially relative to the ring-shaped structure. The ring shaped structures can engage with the hat or be held in place relative to the hat with a clip or other fastener or attachment structure. The ring-shaped structure can non-rigidly engage with the antenna while still allowing movement of the antenna such that the antenna is more comfortable to wear and makes the antenna less likely to deform or break. The ring-shaped structure can be connected to a structure worn by the user to position the antenna relative to a target treatment location on the user. In some cases a plurality of ring-shaped structures can be used to engage the antenna to the structure worn by the user. The ring-shaped structures can be made out of materials such as metal, plastic, polymers, etc. In some cases the ring-shaped structure can be a flexible polymer material, such as a shrink wrap or shrink tubing. In some embodiments the ring-shaped structure can provide some friction to reduce movement between the ring-shaped structure and the antenna while still allowing the antenna to slide relative to the ring-shaped structure.

**[0043]** The generator module is typically adapted to releasably and replaceably mate with the applicator module. Any appropriate connector between the two units may be used, including prongs, plugs, snaps, magnets, Velcro, fasteners, or the like. The connector typically makes an electrical connection between the two so that signals can be transmitted between the generator and the applicator units. Multiple connectors may be used. The connector may be a mechanical connector, an electrical connector, a magnetic connector, or some combination thereof. The connector may also provide physical stability between the two units, preventing physical disruption of the connection. In some variations the apparatus may be configured so that either or both the generator module and the applicator module include a housing that engages with the opposite module.

**[0044]** One variation of a PEMF applicator apparatus is shown in FIG. 1A. In FIG. 1A the apparatus (referred to as "TheraCap" in this example), includes a generator unit **101** that is shown coupled to an applicator unit **103**. The applicator unit includes a loop antenna **105**. The generator unit may include a power source (e.g., batteries), as well as the circuitry for controlling the operation of the device. The

controller (not visible in FIG. 1A) may be a processor (e.g., microprocessor) that is adapted to create and sequence (e.g., time) the RF waveforms to be delivered. The processor or controller may also be adapted to record and/or transmit information about the operation of the device and/or to receive information (control commands) from one or more inputs, including wireless control inputs.

[0045] Thus, the generator unit may user controls and outputs. For example, the generator unit may include an output (such as a display screen, LED, indicator light(s), speaker, etc.). The generator unit may also include one or more inputs, including buttons, dials, sliders, switches, etc. The outer portion of the generator may include a housing. Examples of status indicators may include power (power on, power level, charge level) stimulation indicators (indicating when stimulation is being applied), transmission indicators (indicating when data is being received/transmitted by the apparatus), or the like. For example, in FIG. 1A, the face of the generator includes an LED indicating that PEMF is being applied 133, as well as a low battery indicator 143 and a power on/off indicator 153. FIG. 1B shows the back of the apparatus shown in FIG. 1A. The applicator unit 103 is shown connected to the generator unit 101. The applicator unit includes a housing that holds the circuitry including the RF amplifier circuitry, impedance matching circuitry and connects to the antenna. FIG. 1C shows a slightly enlarged view of the coupled applicator unit 103 coupled to the generator unit 101.

[0046] FIGS. 2A and 2B show front and back perspective views, respectively, of one variation of a generator 201. The generator is shown in FIG. 2A to include an outer housing having a front panel including inputs and outputs (e.g., manual inputs and visual outputs). The back of the housing shown in FIG. 2B includes a door that can open to reveal a battery compartment 211. The back housing also includes an opening for a connector 213. The connector in this example is a female plug into which a male connector on the applicator unit (described below) may attach. In some examples additional attachment sites may be included to connect the generator and the applicator.

[0047] FIG. 2C shows an exploded view of the generator shown in FIGS. 2A and 2B. In this example, the generator includes a two-part housing (top generator housing 219 and bottom generator housing 217) that may be used to enclose the controller and other generator components. The housing may be fastened together in any appropriate means, including snaps, screws 217, or the like. For example, the housing may enclose the power supply (shown in FIG. 2C as two AAA alkaline batteries 215) behind a removable door (battery flap 221). The controller may be part of the internal circuitry. For example, a printed circuit board (PCB) 221 may be housed within the housing and may include the controller/processor as well as any communications module. As mentioned above, the controller/processor may include the signal generator for generating waveforms of the desired frequency and timing. Examples of the desired waveforms are described in U.S. Pat. No. 5,370,680, U.S. Pat. No. 5,584,863, U.S. Pat. No. 5,723,001, U.S. Pat. No. 7,740,574, U.S. Pat. No. 7,744,524, U.S. Pat. No. 7,758,490, U.S. Pat. No. 7,896,797, U.S. Pat. No. 8,343,027, U.S. Pat. No. 8,415,123; U.S. 2010-0210893, U.S. 2010-0222631, U.S. 2013-0274540, U.S. 2014-0046115, U.S. 2014-0046117,

U.S. 2011-0207989, U.S. 2012-0116149, and U.S. 2012-0089201, each of which is again herein incorporated by reference in its entirety.

[0048] FIGS. 3A-3D show examples of front, back, bottom and side views, respectively of a housing of a generator module, including exemplary dimensions. For example, in FIG. 3A, the front of the housing may include outputs such as an audio indicator 305, a low battery indicator 307, an activity indicator 309. One or more inputs (e.g., manual inputs) may also be included, such as a power control 310 (e.g., for turning the device on/off). A start/stop control may also be included. The applicator may also include a couple/uncouple control for coupling the generator to the applicator unit. A couple/uncouple control may prepare the units for attaching and detaching, initiating calibration or matching between the devices, and may engage or disengage the coupling elements holding the two units together. In some variations a coupling/uncoupling control may also trigger a self-check or diagnostic testing, or a shutdown/startup sequence. In general the generator unit may detect when it is connected or disconnected from the applicator unit, and may trigger an error code if disconnected (or if the connection degrades), including if disconnecting without using a disconnection procedure (e.g., pushing a coupling/uncoupling control).

[0049] In FIG. 3C, the bottom of the device is shown, and an in-circuit programming access slit 325 is included, allowing access to the controller/processor. This access may allow in circuit programming without the need to dismantle the enclosure or replace hardware (e.g., IC chips). As mentioned above the controller/processor (e.g., CPU) may include flash memory, enabling parameters to be stored for the use and operation of the device. Information on the operation of the device may be stored and/or transmitted, including the stimulation parameters, run times, error codes related to failure or behavior of the apparatus, the number of treatments applied, etc. Control information, including the waveform configurations, timing (e.g., frequency of application, duration of application, burst frequency within an application, etc.) may be stored within the device and modified by modification of the controller.

[0050] FIG. 3D shows a side view of the generator, including a proposed thickness 330 (e.g., 0.675 inches). Other dimensions are indicated in FIG. 3A (e.g., height 315 of 1.1745 inches, and width 317 of 2.609 inches). In general, these dimensions are intended as exemplary only. Generally the dimensions may be larger or smaller than those indicated. For example, the overall thickness may be much thinner (e.g., less than 0.5 inches, etc.). The smaller dimensions may allow a lighter, and more readily wearable device. As shown in FIG. 3D, one or more edges of the device may be rounded or radiused. As the device is to be worn, this may be beneficial.

[0051] An example of an applicator unit is shown in FIGS. 4A-4C. For example in FIG. 4A, a side perspective view of an applicator module 401 is shown. The applicator unit 401 may include an antenna (in this example, a wire loop antenna 405 is shown. The wire loop antenna shown may be flexible, and bendable, so as to form against the body, or be shaped to permit it to conform to the body. An applicator unit housing 403 is also shown, from which the flexible wire loop antenna 405 extends. One or more coupling elements that are complimentary to connectors or couplers on the generator may be included on the applicator unit. For example in

FIG. 4A, and male connector 407 extends from the applicator unit housing 403. The applicator unit may also include one or more sensors (e.g., touch sensors) as mentioned above, which may detect when the unit is being worn on or against a subject. For example, a touch sensor (capacitive touch sensor) on the applicator unit housing 403 may detect when the applicator is being worn against a subject's skin. Because the energy may be delivered from the antenna through the skin, and even though clothing or bandages, a sensor may be adapted to sense the presence of the subject though one or more intervening layers.

[0052] The connector 407 may be any appropriate connector, and typically electrically couples the generator to the applicator unit. Thus electrical signals may be transmitted to the applicator unit from the generator (e.g., the waveform to be applied). In some variations, as well the applicator unit has a touch sensor, data may be transmitted from the applicator unit to the generator unit. FIG. 4B shows an alternative view of the applicator unit of FIG. 4A, showing the back of the applicator unit housing 40.

[0053] FIG. 4C shows an exploded view of the applicator unit housing of FIGS. 4A and 4B. In this example, the applicator unit housing includes a front housing 421 and a back housing 423 that enclose a circuitry (e.g., on printed circuit board, PCB 427) that typically includes RF amplification circuitry (e.g., class E amplified) and impedance matching circuitry and connections to the loop antenna 405. The housing may include one or more openings (e.g. holes 431) for access to and/or controls for tuning the impedance matching. In FIG. 4C a label or cover 429 ("calibration label") may cover these openings. One or more contact sensors (not visible in the example of FIG. 4C) may be included, e.g., off or on the back housing 423.

[0054] The tuning of the device can be changed by adjusting the capacitance of one or more capacitors in the applicator unit. The one or more holes 431 can provide access to the tuning capacitors within the applicator unit. The tuning capacitors can be variable capacitors. In some embodiments there are two variable capacitors with a first variable capacitor connected to a first end of the loop antenna 405 and a second variable capacitor connected to a second end of the loop antenna 405. The variable capacitors can be adjusted such that the loop antenna 405 produces a PEFM signal or waveform with desired characteristics. The use of a plurality of tuning capacitors allows for the operator or user to quickly adjust the capacitance of the device to allow for more control over the treatment conditions. For example, tuning the capacitors allows for the user to adjust the device properties by balancing between the generator unit and applicator unit.

[0055] In some embodiments the tuning can be performed by placing a probe on the coil. In some cases the probe is placed on the middle of the coil. The probe can be placed on the desired area of the coil that will be closest to the target treatment area of the user. In one example the coil can be tuned such that the applied field results in an induced voltage on the probe that is greater than about 120 mV. In some embodiments the tuning capacitors allow for individual tuning of the applicator to the proper frequency by adjusting the capacitors.

[0056] The generator unit may be combined with applicator unit, as illustrated in FIGS. 5A-5C, to form the apparatus. In FIG. 5A, the generator unit 501 is attached/coupled to the applicator unit 503 through an article of

clothing (such as a cap, bandage, garment, etc.). FIG. 6 shows one example of this. In FIG. 5A, the overall thickness of the applicator unit, intervening garment (not shown) and the generator unit 511 is shown as approximately 1.029 inches (assuming a gap/thickness of the intervening garment 509 of 0.059 inches). Thus, the connectors described herein may be adapted to couple the generator unit and the applicator unit in a manner that permits the two to be coupled together through a bandage, garment, cap, helmet, or the like.

[0057] FIGS. 5B and 5C show top and front views, respectively, of the partial apparatus shown in FIG. 5A (the applicator antenna is only partially shown in FIGS. 5A-5C). FIGS. 5B and 5C show exemplary dimensions. As mentioned, FIG. 6 shows one example of an applicator attached to a garment (a cap, referred to herein as a "TheraCap"). The cap (hat) includes the applicator on an inner surface (closest to the region worn against the head (not show), e.g., around the brim of the hat. The cap may be adapted for connecting the generator unit with the applicator unit through the cap. For example, a window, opening or the like may be included in the cap where the generator unit and applicator unit may couple to each other. In some variations the cap may include a holder (e.g., frame, pocket, pouch, etc.) to hold the generator.

[0058] In operation, the functions of the PEMF delivery apparatus may be divided between a generator unit and an applicator unit. FIG. 7 shows a schematic of a prior art apparatus in which an amplifier (RF power amplifier) was directly connected/integrated with the signal generator. In FIG. 7, the portion of the device including the signal generator 705 ("device" 701) is directly connected to an RF power amplifier 707 (in this example, the RF power amplifier is a 50 ohm power amplifier that includes tuning circuitry 708 for impedance matching). The device is connected or connectable via an appropriate RF connector 709 (e.g., shown as a 50 ohm connector in FIG. 7), which connects via a transmission line 711 that is also impedance matched (e.g., 50 ohm) to a tunable 714 impedance matching circuit 713 coupled to the applicator antenna 715. In this arrangement, the radio frequency power amplified and applicator antenna impedance matching circuits are separated. To achieve maximum efficiency, the impedance of all components of the RF power pathway must have the same impedance. The transmission line and RF connector have fixed characteristic impedance values (shown in this example as 50 ohms). The RF power amplified and applicator antenna contain impedance-adjustable circuits to match the impedance of the transmission line.

[0059] FIG. 8 shows a schematic of the apparatuses described herein, in which the separable generator unit 801 includes the signal generator, but not any RF amplification. The RF amplifier is instead included in just the applicator unit 803. As described above, the power amplifier in this example is incorporated into the applicator and intrinsically paired to the high Q-factor impedance matching circuit. This may allow the applicator to be removable without suffering RF power losses due to transmission line impedance mismatching (e.g., due to poor connection, drift, and noise). In FIG. 8, the processor (controller/processor 805) generates the stimulation waveform having the shape and timing characteristics. The signal transmitted to the amplifier may be unamplified and may be encoded with the amplification information (e.g., including the desired amplification/fre-

quency components) that may be acted on at the applicator by the on-board RF power amplifier **807**. The connection **809** between the generator unit **801** and the applicator **803** may be adapted specifically to pass both the signal wave-form information (e.g., shape, timing, frequency, etc.) used by the amplifier to apply to the antenna, as well as the power (DC, AC, offset AC, etc.) to drive the applicator unit. As mentioned above, the connector may also pass signals from the applicator to the generator unit (e.g., feedback, sensor information, error codes, etc.). In addition to the RF power amplifier **807**, the circuitry in the applicator may include impedance matching/tuning **808/814** circuitry **808, 814, 813** for either or both the RF power amplifier and the applicator antenna **815**.

**[0060]** In general, any of the apparatuses described herein may be adapted to operate in a power-saving mode, for example, the applicator and/or generator unit may include a sensor (e.g., capacitive touch sensor) to determine when the unit is in contact with a subject's body. This optional touch sensor may be integrated into the applicator to allow automatic regulation of operation depending on when the apparatus is being worn or not. In general, the generator unit may include a standby mode that consumes little power (e.g., 1 to 19 uA). Standby mode may be entered when the device is not being worn and/or between stimulation periods.

**[0061]** In use, the applicator unit may be attached to a subject's body on, over and/or around the target tissue. Thus, an applicator unit, including the antenna, may be coupled to the patient so that the applicator can be worn. For example, in some variations the target tissue includes the subject's head, for delivery of PEMF to the brain and neural tissue. If the target is the head, for example, the applicator may be worn as part of a cap, hat, helmet, or bandage (see, e.g., FIG. **6**). The flexible antenna loop may be placed or present within the brim of the cap, hat, etc. Prior to a desired start of therapy, the apparatus may be prepared by connecting a generator unit to the applicator unit. For example a generator unit which is sufficiently charged (e.g., having on-board battery power) may be coupled to the applicator unit worn by the subject. In the example in FIG. **6**, a generator unit may be snapped onto the applicator unit worn in the cap. The generator unit may connect by one or more connectors. Connecting may trigger to the generator (controller) that the device is connected and can be used to apply PEMF energy. The apparatus may then run one or more checks to determine and/or confirm the status of the connection. For example, the apparatus may trigger the connection is active and ready for operation. The apparatus may also confirm that the device is ready for operation based on a contact sensor on the device (e.g., indicating that the apparatus is in contact with the subject to be treated. Application of a treatment regime may then begin. The controller in the generator may control the treatment regime (e.g., pulse length, pulse width, pulse duration, repetition rate, etc.). During the process of connecting, activating and treating, one or more indicators may be active or activated. Any appropriate indicators may be used, including visual, audible, thermal and tactile. In particular, a subject may receive tactile feedback that the apparatus is operating when signal/energy (PEMF) is being applied.

**[0062]** FIG. **9** illustrates an embodiment of a wearable two-part therapeutic PEMF apparatus configured in a baseball cap **900** with the generator **902** not attached to the baseball cap **900**. The baseball cap **900** includes an opening

**904** configured to allow a connector on the generator unit **902** to connect to the applicator unit (not shown). The generator unit **902** includes a magnet that can be used to hold the generator unit to the applicator unit. In some embodiments powerful magnets, such as rare-earth or static magnets are used to hold the generator unit and applicator unit together.

**[0063]** The generator unit with the power supply is held on the outside of the cap. In some cases the generator unit can also be held via a mechanical attachment to the cap, such as using Velcro or other fasteners. The magnetic connection can be used in addition to or instead of a mechanical connection between the generator unit/power supply and the cap. The magnetic connection can securely hold the generator connected to the applicator unit and coil. The magnetic connection allows the generator unit and applicator to be easily and quickly connected.

**[0064]** In the embodiments illustrated in FIG. **9**, the loop coil is held in a floating configuration within the inside near the brim of the hat (e.g., edge of the cap). The loop coil is positioned in this location because the target for the effect of the PEMF signal is a region near the midpoint of the frontal lobe. Thus placing the coil in this plane passes the signal through the target treatment location. The coil is held just above the hat band in the embodiments illustrated in FIG. **9**. The coil can be positioned anywhere in the cap to deliver the PEMF signal to the target treatment location on the user.

**[0065]** The power supply/generator may be easily swapped out or removed by the user. The generator is held on the right front side of the cap **900** illustrated in FIG. **9**. In some embodiments the generator unit may be held anywhere on the cap. In the embodiments illustrated in FIG. **9** the generator location is mostly for aesthetic reasons. In some embodiments the generator unit can be located anywhere along the plane of the coil.

**[0066]** As described herein the generator unit can have a lightweight and small profile. The illustrated generator unit **902** weighs less than about 3 ounces and has a height of less than about 2 inches, a width of less than about 3 inches, and a thickness of less than about 0.5 inches. The generator unit **902** includes a power supply that can include one or more replaceable batteries to power the device. In some embodiments AAA batteries are used. In some embodiments the generator unit can be made smaller and lighter depending on the size of the batteries used for the power supply. The battery can be replaced by removing the generator unit from the hat.

**[0067]** FIG. **10** illustrates a plurality of loop antennas **1000** with applicator units **1004** in accordance with some embodiments. The loop antennas **1000** are illustrated as engaged with a plurality of ring-shaped structures **1002**. Each of the loop antennas are illustrated with four ring-shaped structures **1002**. The ring-shaped structures **1002** can be attached to the hat via a clip or other attachment mechanism. The ring-shaped structures **1002** include an open channel that holds the loop antenna **1000**. The ring-shaped structures **1002** can engage with the hat to hold the loop antenna to the hat in a non-rigid manner. The loop antenna **1000** can slide relative to the ring-shaped structure **1002** axially through the interior volume of the ring-shaped structure and within a plane formed by the interior volume of the ring-shaped structure. The ring-shaped structure **1002** can hold the loop antenna **1000** in approximately the same plane within the hat such that the coil treats the targeted area of the user. The ring-

shaped structure **1002** allows the loop antenna **1000** to move within the hat, making the loop antenna **1000** more comfortable to wear and also making it less likely for the loop antenna **1000** to break and/or deform during use. In some embodiments the ring-shaped structure can produce some friction between the loop antenna and the ring-shaped structure. For example the ring shaped structure can be made out of a rubber, shrink wrap material, shrink tubing and/or could have a roughened surface, or other surface that can cause friction against the loop antenna.

[0068] FIGS. 11A-11E illustrate various aspects of a two-part therapeutic PEMF apparatus. FIGS. 11A and 11B illustrate a front view and a back view of a first part **1100** of a two-part PEMF apparatus including an applicator unit **1102** and loop antenna **1104**. The back of the applicator unit **1102** includes a connector **1106** and two magnets **1108**. The front of the applicator unit **1102** includes a first tuning capacitor **1110** and a second tuning capacitor **1112**. The tuning capacitors **1110**, **1112** are configured to be tuned by turning a screw head within the housing of the applicator unit **1102**. FIG. 11C illustrates the applicator unit **1102** and loop antenna **1104** within a cap **1114**. The loop antenna **1104** is engaged with a ring-shaped structure **1116**. FIG. 11D illustrates an applicator unit **1102** and loop antenna **1104** engaged with a plurality of ring-shaped structures **1116**. FIG. 11E illustrates the loop antenna **1104** secured to the cap **1114** by securing the ring-shaped structure **1116** to the cap **1114**. The ring-shaped structure **1116** can be clipped or fastened to the cap **1114** to non-rigidly secure the loop antenna **1104** within the cap **1114**. The loop antenna **1104** can slide through the interior volume of the ring-shaped structures **1116**.

[0069] FIGS. 12A-12C illustrate various aspects of a two-part therapeutic PEMF apparatus that can be used with the embodiments illustrated in FIGS. 11A-11E. FIG. 12A illustrates the cap engaged with the applicator unit **1102** such that the connector **1106** and two magnets **1108** protrude through an opening in the cap **1114**. FIG. 12B illustrates a generator unit **1118** with a connector **1120** and magnets **1122**. The illustrated connector **1120** has a female receptacle that is configured to complementarily engage with the connector **1106** on the applicator unit **1102**. The magnets **1122** of the generator unit **1118** are configured to engage with the magnets **1108** of the applicator unit. FIG. 12C illustrates the cap **1118** with the generator unit **1118** engaged with the applicator unit.

[0070] Although many of the variations and examples described above are specific to hat or wearable devices, any of these apparatuses may be non-wearable. For example, in some variations the apparatuses are integrated into furniture (e.g., bedding, chairs, etc.) or sleeping devices (e.g., pillows, bedding, mattresses, cushions, etc.), and particularly those configured so that the user places his or her head on the device.

[0071] For example, in some variations, the apparatus is configured as a pillow or mattress (e.g., bedding). In FIG. 13A, for example, the apparatus is configured as a travel pillow **1301** that includes an applicator **1304** loop that is incorporated near an outer portion (though internal to the pillow and/or pillow cover). FIG. 13A shows a travel pillow that is engaged with the applicator loop **1304** such that an applicator unit **1302** (similar to the applicator units described above, including one or more connectors, e.g., magnets), that is present on an outer surface of the pillow. The applicator loop **1304** is positioned on a region of the

pillow where the user will position her or his head when wearing the pillow, as shown in FIG. 13A.

[0072] Any of these apparatuses may also be two-part therapeutic PEMF apparatuses. For example, in FIGS. 13A to 13B, the pillows are configured as two-part PEMF apparatuses and configured so that a first part of a two-part PEMF apparatus including an applicator unit **1302** and loop antenna **1304** is integrated into the pillow. As mentioned, the applicator unit **1302** includes a connector **1306** which may include one or more (e.g., two) magnets. As discussed above, the applicator unit **1302** may also include a first tuning capacitor and a second tuning capacitor (not shown) configured to be tuned by turning a screw head within the housing of the applicator unit **1302**.

[0073] Any of these pillows may also be marked to indicate “top” or “bottom” or specifically indicate where the applicator is, so that the user can position their head close to the loop. As mentioned, the applicator may be held within the pillow near an outer surface, or in or between a cover (e.g., pillow case) over a cushion of the pillow. In FIG. 13A, the applicator unit **1302** is shown on an upper surface of the pillow, away from the region where the user’s head will rest; in general the applicator unit may be located anywhere on (or in some variations, in) the pillow, so that the generator unit **1318** may be connected unobtrusively, but may be easily swapped out. For example, the applicator unit may be located in a pocket that may also hold the generator unit; this pocket may be on an outer surface (not shown) on an inner surface, away from where the head will rest (e.g., on the back portion of the pillow), for comfort. In this example, the pillow or cushion shown is a travel-type pillow configured with a curved/U-shape so that it can fit around a user’s neck. In general, the pillow may have any appropriate shape, including traditional rectangular/square shapes, as illustrated in FIGS. 13B (back) and 13C (front).

[0074] For example, in FIG. 13B, the back of a pillow **1311** is shown, with the connector **1306** of the applicator unit **1302** located in one corner. In this example, the first part of the two-part apparatus (including the applicator coil) may be integrated into the pillow or into a pillow holder/case in which the pillow fits. A generator unit **1318** that is adapted to connect to the connector of the applicator unit (e.g., by one or more fasteners such as snaps, magnets, etc.) is also shown in FIG. 13B. The connector region of the shown in this example includes a female receptacle that is configured to complementarily engage with the connector **1106** on the applicator unit **1102**. The magnets **1122** of the generator unit **1118** are configured to engage with the magnets **1108** of the applicator unit. FIG. 12C illustrates the cap **1118** with the generator unit **1118** engaged with the applicator unit.

[0075] FIG. 13C shows a front view (or top view) of the pillow apparatus of FIG. 13B; the applicator loop **1304** is shown in the dashed lines, as it may be located (and connected to the applicator unit by one or more wires, not shown) within the pillow or pillow covering, or between the pillow and pillow covering, as mentioned above.

[0076] In use, any of the two part-devices described herein may be configured so that a first part that is attached to the hat, garment, furniture, pillow, etc., and the second part may be removably attached to the first part to provide power and/or signals to the applicator of the first part. The same second part may be used interchangeably with multiple first parts.

**[0077]** When a feature or element is herein referred to as being “on” another feature or element, it can be directly on the other feature or element or intervening features and/or elements may also be present. In contrast, when a feature or element is referred to as being “directly on” another feature or element, there are no intervening features or elements present. It will also be understood that, when a feature or element is referred to as being “connected”, “attached” or “coupled” to another feature or element, it can be directly connected, attached or coupled to the other feature or element or intervening features or elements may be present. In contrast, when a feature or element is referred to as being “directly connected”, “directly attached” or “directly coupled” to another feature or element, there are no intervening features or elements present. Although described or shown with respect to one embodiment, the features and elements so described or shown can apply to other embodiments. It will also be appreciated by those of skill in the art that references to a structure or feature that is disposed “adjacent” another feature may have portions that overlap or underlie the adjacent feature.

**[0078]** Terminology used herein is for the purpose of describing particular embodiments only and is not intended to be limiting of the invention. For example, as used herein, the singular forms “a”, “an” and “the” are intended to include the plural forms as well, unless the context clearly indicates otherwise. It will be further understood that the terms “comprises” and/or “comprising,” when used in this specification, specify the presence of stated features, steps, operations, elements, and/or components, but do not preclude the presence or addition of one or more other features, steps, operations, elements, components, and/or groups thereof. As used herein, the term “and/or” includes any and all combinations of one or more of the associated listed items and may be abbreviated as “/”.

**[0079]** Spatially relative terms, such as “under”, “below”, “lower”, “over”, “upper” and the like, may be used herein for ease of description to describe one element or feature’s relationship to another element(s) or feature(s) as illustrated in the figures. It will be understood that the spatially relative terms are intended to encompass different orientations of the device in use or operation in addition to the orientation depicted in the figures. For example, if a device in the figures is inverted, elements described as “under” or “beneath” other elements or features would then be oriented “over” the other elements or features. Thus, the exemplary term “under” can encompass both an orientation of over and under. The device may be otherwise oriented (rotated 90 degrees or at other orientations) and the spatially relative descriptors used herein interpreted accordingly. Similarly, the terms “upwardly”, “downwardly”, “vertical”, “horizontal” and the like are used herein for the purpose of explanation only unless specifically indicated otherwise.

**[0080]** Although the terms “first” and “second” may be used herein to describe various features/elements, these features/elements should not be limited by these terms, unless the context indicates otherwise. These terms may be used to distinguish one feature/element from another feature/element. Thus, a first feature/element discussed below could be termed a second feature/element, and similarly, a second feature/element discussed below could be termed a first feature/element without departing from the teachings of the present invention.

**[0081]** As used herein in the specification and claims, including as used in the examples and unless otherwise expressly specified, all numbers may be read as if prefaced by the word “about” or “approximately,” even if the term does not expressly appear. The phrase “about” or “approximately” may be used when describing magnitude and/or position to indicate that the value and/or position described is within a reasonable expected range of values and/or positions. For example, a numeric value may have a value that is  $\pm 0.1\%$  of the stated value (or range of values),  $\pm 1\%$  of the stated value (or range of values),  $\pm 2\%$  of the stated value (or range of values),  $\pm 5\%$  of the stated value (or range of values),  $\pm 10\%$  of the stated value (or range of values), etc. Any numerical range recited herein is intended to include all sub-ranges subsumed therein.

**[0082]** Although various illustrative embodiments are described above, any of a number of changes may be made to various embodiments without departing from the scope of the invention as described by the claims. For example, the order in which various described method steps are performed may often be changed in alternative embodiments, and in other alternative embodiments one or more method steps may be skipped altogether. Optional features of various device and system embodiments may be included in some embodiments and not in others. Therefore, the foregoing description is provided primarily for exemplary purposes and should not be interpreted to limit the scope of the invention as it is set forth in the claims.

**[0083]** Throughout this specification and the claims which follow, unless the context requires otherwise, the word “comprise”, and variations such as “comprises” and “comprising” means various components can be conjointly employed in the methods and articles (e.g., compositions and apparatuses including device and methods). For example, the term “comprising” will be understood to imply the inclusion of any stated elements or steps but not the exclusion of any other elements or steps.

**[0084]** The examples and illustrations included herein show, by way of illustration and not of limitation, specific embodiments in which the subject matter may be practiced. As mentioned, other embodiments may be utilized and derived there from, such that structural and logical substitutions and changes may be made without departing from the scope of this disclosure. Such embodiments of the inventive subject matter may be referred to herein individually or collectively by the term “invention” merely for convenience and without intending to voluntarily limit the scope of this application to any single invention or inventive concept, if more than one is, in fact, disclosed. Thus, although specific embodiments have been illustrated and described herein, any arrangement calculated to achieve the same purpose may be substituted for the specific embodiments shown. This disclosure is intended to cover any and all adaptations or variations of various embodiments. Combinations of the above embodiments, and other embodiments not specifically described herein, will be apparent to those of skill in the art upon reviewing the above description.

1. (canceled)
2. A method of applying pulsed electromagnetic field (PEMF) energy to a subject from a modular device, the method comprising:

connecting an applicator unit to a generator unit;  
 generating a PEMF waveform using a signal generator in the generator unit;  
 transmitting waveform information about the PEMF waveform to a radio frequency (RF) power amplifier in the applicator unit;  
 generating a PEMF signal based on the waveform information;  
 matching an impedance between the RF power amplifier and a loop antenna coupled to the RF power amplifier through an impedance matching circuit; and  
 delivering the PEMF signals to the subject.

3. The method of claim 2, wherein connecting comprises releasably connecting.

4. The method of claim 2, further comprising storing information about one or more of applied stimulation, operational status, or error codes.

5. The method of claim 2, further comprising operating a couple/uncouple control to engage or disengage the generator unit from the applicator unit.

6. The method of claim 2, further comprising wirelessly transmitting data to the generator unit.

7. The method of claim 2, wherein matching the impedance comprises using one or more variable capacitors to match the impedance between the RF power amplifier and a loop antenna.

8. The method of claim 2, wherein transmitting the waveform information about the PEMF waveform comprises transmitting the PEMF waveform.

9. The method of claim 2, wherein transmitting the waveform information about the PEMF comprises transmitting one or more of: shape, timing, frequency.

10. The method of claim 2, further comprising magnetically connecting the generator unit and the applicator unit.

11. A method of applying pulsed electromagnetic field (PEMF) energy to a subject from a modular device, the method comprising:

releasably connecting an applicator unit to a generator unit;

generating a PEMF waveform using a signal generator in the generator unit;

transmitting the waveform information about the PEMF waveform to a radio frequency (RF) power amplifier in the applicator unit through the releasable connection;

generating a PEMF signal based on the waveform information;

matching an impedance between the RF power amplifier and a loop antenna coupled to the RF power amplifier through an impedance matching circuit; and

delivering the PEMF signals to the subject.

12. The method of claim 11, further comprising storing information about one or more of applied stimulation, operational status, or error codes.

13. The method of claim 11, further comprising operating a couple/uncouple control to engage or disengage the generator unit from the applicator unit.

14. The method of claim 11, further comprising wirelessly transmitting data to the generator unit.

15. The method of claim 11, wherein matching the impedance comprises using one or more variable capacitors to match the impedance between the RF power amplifier and a loop antenna.

16. The method of claim 11, wherein transmitting the waveform information about the PEMF waveform comprises transmitting the PEMF waveform.

17. The method of claim 11, wherein transmitting the waveform information about the PEMF comprises transmitting one or more of: shape, timing, frequency.

18. The method of claim 11, further comprising magnetically connecting the generator unit and the applicator unit.

\* \* \* \* \*