



(12) **EUROPEAN PATENT SPECIFICATION**

(45) Date of publication and mention
of the grant of the patent:

11.12.2002 Bulletin 2002/50

(21) Application number: **95903477.8**

(22) Date of filing: **23.11.1994**

(51) Int Cl.7: **H04Q 7/22, H04L 12/56**

(86) International application number:
PCT/SE94/01120

(87) International publication number:
WO 95/016330 (15.06.1995 Gazette 1995/25)

(54) **APPARATUSES AND MOBILE STATIONS FOR PROVIDING PACKET DATA COMMUNICATION IN DIGITAL TDMA CELLULAR SYSTEMS**

VORRICHTUNGEN UND MOBILSTATIONEN FUER PAKETDATENKOMMUNIKATION IN DIGITALEN TDMA ZELLULAREN SYSTEMEN

APPAREILS ET STATIONS MOBILES PERMETTANT D'ASSURER LA COMMUNICATION PAR PAQUETS DE DONNEES DANS DES SYSTEMES CELLULAIRES AMRT

(84) Designated Contracting States:
DE DK ES FR GB GR IT NL SE

(30) Priority: **10.12.1993 SE 9304119**

(43) Date of publication of application:
29.11.1995 Bulletin 1995/48

(60) Divisional application:
01128387.6 / 1 191 800

(73) Proprietor: **TELEFONAKTIEBOLAGET LM
ERICSSON
126 25 Stockholm (SE)**

(72) Inventors:
• **BILLSTRÖM, Lars, Axel
S-171 60 Solna (SE)**

- **WETTERBORG, Lars, E.
S-175 45 Järfälla (SE)**
- **DAHLIN, Jan, Erik, Ake, Steinar
S-175 45 Järfälla (SE)**
- **PERSSON, Bengt, Yngve
S-182 05 Djursholm (SE)**

(74) Representative: **Wennerholm, Kristian et al
Ericsson Radio Systems AB,
Patent Unit Radio Access
164 80 Stockholm (SE)**

(56) References cited:
**CA-A- 2 063 901 US-A- 4 887 265
US-A- 5 195 090**

- **ETSI TDOC smal 238/93 Packet Data Over GSM
Network 1993-09-28, J. HAMALAINEN et al., see
Table, page 3, paragraphs 4.1, 4.2.**

Description

FIELD OF THE INVENTION

[0001] This invention relates to digital TDMA (Time Division Multiple Access) cellular radio mobile telecommunications systems. More specifically, the present invention is directed towards apparatuses and mobile stations for providing packet data communications services in current TDMA cellular systems as defined in the preambles of claims 1 and 30.

BACKGROUND OF THE INVENTION

[0002] Mobile data communication is rapidly becoming one of the fastest growing segments of the mobile communications market. Independent market studies predict several million users in Europe by the year 2000. A strong driving force is the fast growing portable personal ("laptop", "palmtop" and "notebook") computer market and the need for flexible wireless data communications it creates. This market force is further emphasized by the emerging new communication-centered devices, commonly referred to as "Personal Digital Assistants" or "Personal Communicators". Target applications include:

- The wide range of standard business applications today predominantly used across fixed data networks, such as electronic mail and host computer/data base access.
- Specialized mobile data applications including vehicle fleet control and road transport informatics.
- Fixed wireless applications, including remote monitoring and control applications, and credit card verification and similar financial transaction applications.
- Possible new applications as a result of the convergence of the two enabling technologies of new personal computing/communicating devices and efficient and widely available mobile data communications.

[0003] To support this variety of applications in a cost effective manner, a mobile data network should:

- Provide packet mode data services based on shared packet data radio channels optimized for packet data (exploiting the bursty nature of most data communications applications) to achieve spectrum efficiency and cost effectiveness.
- Provide industry standard network services, including standard connectionless network (datagram) services and, depending on market requirements, standard connection-oriented network (virtual call) services e.g. to provide transparent X.25 connectivity.
- Provide performance (packet transfer delays) com-

parable to what is provided by current fixed networks, to allow existing standard applications to be used without modification.

- Provide broadcast and multicast services to support specialized mobile applications.

[0004] Providing the packet data services on a cellular system platform offers potential advantages in terms of widespread availability, possibility of combined voice/data services, and comparatively low additional investments by capitalizing on the cellular infrastructure. Of particular interest are current TDMA cellular systems, through their spectrum efficiency and world wide penetration. Examples of potential TDMA platforms include:

- GSM (Global System for Mobile communication)
- Systems with a GSM type of architecture but operating in other frequency bands, such as the 1800 and 1900 MHz bands, including PCN (Personal Communications Network) in Europe and PCS (Personal Communications Services) in the U.S.A.
- The North American D-AMPS (Digital Advanced Mobile Phone Service) system.
- The Japanese PDC (Personal Digital Cellular) system.

[0005] However, the data services provided by or proposed for cellular systems in general are with few exceptions based on circuit mode of operation, using a dedicated radio channel for each active mobile user. The exceptions include the packet data concepts described in the following documents:

a)US-A-4,887,265 and Proc. 38th IEEE Vehicular Technology Conference, June 88, Philadelphia (U.S.), pages 414-418: "Packet Switching in Digital Cellular Systems".

[0006] These documents describe a cellular system providing shared packet data radio channels, each one capable of accomodating multiple data calls. A mobile station requesting packet data service is assigned to a particular packet data channel using essentially regular cellular signalling. The system may include Packet Access Points (PAPs) for interfacing with packet data networks. In that case, each packet data radio channel is connected to one particular PAP and is thus capable of multiplexing data calls associated with that PAP. System initiated handover (handoff) is employed, to a large extent similar to the type of handover used in the same system for voice calls. A new type of handover is added for handling situations when the capacity of a packet channel is insufficient.

b)US-A-4,916,691.

[0007] This document describes (for one of the embodiments) a new packet mode cellular radio system ar-

chitecture, and a new procedure for routing (voice and/or data) packets to a mobile station. Base stations, public switches via trunk interface units, and a cellular control unit are linked together via a wide area network. The routing procedure is based on mobile station initiated handover and on adding to the header of any packet transmitted from a mobile station (during a call) an identifier of the base station through which the packet passes. In case of an extended period of time between subsequent user information packets from a mobile station, the mobile station may transmit extra control packets for the sole purpose of conveying cell location information. The cellular control unit is primarily involved at call establishment, when it assigns to the call a call control number. It then notifies the mobile station of the call control number and the trunk interface unit of the call control number and the identifier of the initial base station. During a call, packets are then routed directly between the trunk interface unit and the currently serving base station.

c) Cellular Digital Packet Data (CDPD) System Specification, Release 1.0, July, 1993.

[0008] CDPD is a new concept for providing packet data services, utilizing available radio channels on current Advanced Mobile Phone Service AMPS systems (i.e. the North American Analog Cellular System). CDPD is a comprehensive, open specification endorsed by a group of U.S. cellular operators. Items covered include external interfaces, air interfaces, services, network architecture, network management, and administration. The CDPD system specified is to a large extent based on an independent infrastructure. Common denominators with AMPS systems are limited to utilization of the same type of radio frequency channels and the same base station sites (the base station itself, used by CDPD, is new and CDPD specific), and employment of a signalling interface for coordinating channel assignments between the two systems. Routing a packet to a mobile station is based on, first routing the packet to a home network node (home Mobile Data Intermediate System, MD-IS) equipped with a home location register (HLR), based on the mobile station address; then, when necessary, routing the packet to a visited, serving MD-IS based on HLR information; and finally transferring the packet from the serving MD-IS via the current base station, based on the mobile station reporting its cell location to its serving MD-IS.

d) ETSI (European Telecommunications Standards Institute) T Doc SMG 4 58/93, Feb. 12, 1993: "Packet Radio in GSM"; and "GSM in a future competitive environment", seminar, Helsinki, Oct. 13, 1993: "A General Packet Radio Service Proposed for GSM".

[0009] These documents outline a possible packet access protocol for voice and data in GSM.

e) ETSI T Doc SMG 1 238/93, Sep. 28, 1993: "Packet Data over GSM Network".

[0010] This document describes a concept of providing packet data services in GSM based on first using regular GSM signalling and authentication to establish a virtual channel between a packet mobile station and an "Agent", handling access to packet data services. With regular signalling modified for fast channel setup and release, regular traffic channels are then used for packet transfer.

[0011] Of the above documents, documents d) and e) directly relate to a TDMA cellular system. Documents d), although outlining a possible organisation of an optimized shared packet data channel, do not deal with the aspects of integrating packet data channels in a total system solution.

[0012] The concept described in document e), being based on using a "fast switching" version of existing GSM traffic channel, has disadvantages in terms of spectrum efficiency and packet transfer delays (especially for short messages) compared to a concept based on optimized shared packet data channels.

[0013] The system described in documents a) is data call oriented and based on using system initiated handover in a similar way as for regular voice calls. Applying these principles for providing general purpose packet data services in a TDMA cellular system would imply spectrum efficiency and performance disadvantages. For example, system initiated handover in GSM is based on allocating 1/26 of a traffic channel capacity during a call for signalling related to monitoring and controlling signal quality (for a single mobile station) in preparation for a possible handover.

[0014] The systems described in documented b) and c) are not directly related to the specific problems of providing packet data services in TDMA cellular systems.

[0015] Canadian Patent Application No. 2,063,901 describes a cellular overlay system. The cellular data overlay system monitors the use of voice channels used by the voice communication system. If there is an absence of voice communication on the associated voice channel, the data basestation transmits an available-channel signature to identify the data-allocated channel as available for data service.

[0016] To summarize, there is a need for a system concept for providing general purpose packet data services in TDMA cellular systems, based on providing shared packet data channels optimized for packet data.

DISCLOSURE OF THE INVENTION

[0017] The overall object of the present invention is to provide system concepts for providing general purpose packet data communication services in current digital TDMA cellular systems, based on providing spectrum efficient shared packet data channels optimized for packet data and compatible with cellular requirements.

Target systems include GSM systems, systems based on GSM architecture but operating in other frequency bands (e.g. the 1800 and 1900 MHZ bands), D-AMPS and PDC systems.

[0018] Specifically, an object of the invention is to provide an "integrated" system concept that provides the new packet data services in a closely integrated way, utilizing the current TDMA cellular infrastructure to the extent possible consistent with packet data functional and performance requirements.

[0019] It is another object of the invention to provide a mobile station for packet data communication over TDMA cellular shared packet data channels enabled by the integrated system concept.

[0020] These objectives are attained by apparatuses and mobile stations as defined in the characterizing clauses of claims 1 and 30, and associated subclaims.

BRIEF DESCRIPTION OF THE DRAWINGS

[0021] FIG. 1 illustrates an embodiment of the "integrated" system concept applied to a GSM system ("Embodiment I"), by showing a block diagram of a GSM system enhanced with packet data (PD) functions, the major PD function blocks shown with bold contour lines.

[0022] FIG. 2 illustrates an intranetwork protocol and interworking example (Internet Protocol IP) for Embodiment I.

[0023] FIG. 3 illustrates an intranetwork protocol and interworking example (X.25) for Embodiment I.

[0024] FIG. 4 illustrates a new PD state (PD mode), introduced in Embodiment I, in relation to regular GSM idle state (mode) and call-connected state (mode).

[0025] FIG 5 shows a sequence diagram illustrating establishment of PD state (PD mode), initiated from a mobile station (MS).

[0026] FIG 6 shows an example of a 51-frame Master packet data channel (MPDCH) downlink multiframe, together with the multiframe cycle in FIG. 7 provided for coordinating listening to MPDCH with listening to regular GSM broadcast channels (applicable both to Embodiment I and "Embodiment II" below).

[0027] FIG. 7 shows an example of a multiframe cycle formed by 8 MPDCH downlink multiframes (illustrated in FIG. 6), and an example of scheduling adequate times for listening to regular GSM broadcast channels.

[0028] FIG. 8 shows a sequence diagram illustrating allocation of a packet data channel (PDCH) on demand, initiated from an MS (applicable to Embodiment I).

[0029] FIG. 9 shows a flow chart, illustrating the process of dynamically allocating PDCHs based on throughput measurements (applicable both to Embodiment I and II).

[0030] FIG. 10 shows a sequence diagram illustrating an example of a mobile originated packet transfer in Embodiment I.

[0031] FIG. 11 shows a sequence diagram illustrating an example of a mobile terminated packet transfer (us-

ing "immediate channel reservation") in Embodiment I. **[0032]** FIG. 12 shows a sequence diagram illustrating an example of a mobile terminated packet transfer (using paging) in Embodiment I.

[0033] FIG. 13 shows examples of a mobile originated and a mobile terminated packet transfer on an MPDCH, thereby illustrating the principles of using Uplink State Flags (USFs) and a type of paging that reserves an access slot for the MS to respond (applicable both to Embodiment I and II).

[0034] FIG. 14 illustrates an example of routing from an interworking function (IWF) to an MS's currently serving Mobile services Switching Centre (MSC) in Embodiment I, when the addressing scheme chosen is such that an MS's IP address identifies the MS as belonging to a particular public land mobile network (or group of MSCs).

[0035] FIG. 15 illustrates an example of routing from an IWF to an MS's currently serving MSC in Embodiment I, when the addressing scheme chosen is such that an MS's IP address identifies the MS as belonging to a particular MSC.

DESCRIPTION OF PREFERRED EMBODIMENTS

[0036] An embodiment of the invention is described, which is applied to a digital TDMA cellular system with a GSM type of architecture. Although this type of system may operate in another frequency band (such as the 1800 or 1900 MHZ band) than that specified for GSM, it is in the following description referred to as a "GSM system". The present invention is directed towards providing the new packet data services in a closely integrated way, utilizing the current infrastructure to the extent possible, consistent with functional and performance requirements.

[0037] The description focuses on the new packet data functions introduced. Descriptions of the GSM system as implemented by Ericsson may be found in Ericsson Review No. 3, 1991 and in "CME 20 Training Document" with the Ericsson designation EN/LZT 120 226 R3A.

I. EMBODIMENT 1

I.A Overview

[0038] FIG. 1 illustrates a GSM system enhanced with packet data (PD) functions, the major PD function blocks shown with bold contour lines. A plurality of Base Transceiver Stations (BTSs), each providing radio communication service to multiple Mobile Stations (MSs) in one cell, together provide complete coverage of the GSM Public Land Mobile Network (PLMN) service area. Only one BTS and one MS are shown schematically in the figure. It comprises a Mobile Termination (MT) and a Terminal Equipment (TE) part. A group of BTSs is controlled by a Base Station Controller (BSC), and these together form a Base Station System (BSS). One or

more BSSs are served by a Mobile services Switching Centre (MSC) with an associated Visitor Location Register (VLR). An MSC controls calls to and from other networks such as PSTN (Public Switched Telephone Network), ISDN (Integrated Services Digital Network), or other PLMN networks. An MSC equipped for routing incoming calls is referred to as a Gateway MSC (GMSC). One or more MSC service areas together constitute the PLMN service area. Furthermore, the MSC/VLR(s) are via a CCITT (International Telegraph & Telephone Consultative Committee) Common Channel Signalling (CCS) system No. 7 network connected to a Home Location Register (HLR), which is a data base comprising information on all subscribers, including location information identifying the MSC/VLR where a subscriber is currently (or was last) registered. Connected to HLR, is an Authentication Centre (AUC), that provides HLR with authentication parameters. To allow identification of subscriber equipment, an Equipment Identity Register (EIR) is provided, connected to the MSC(s). Finally, an Operations and Maintenance Centre (OMC) may be included for providing overall network support.

[0039] The packet data functionality added in BTS includes capability to provide one or more shared packet data channels (here referred to as "PDCHs"), depending on demand. In a cell, only occasionally visited by a packet data user, a PDCH may be allocated temporarily on user demand. In a cell with continuous packet data traffic demand on the other hand, one or more PDCHs may either be allocated on a semi-permanent basis, or be allocated dynamically, adapted to the current load situation. The allocation of PDCHs is controlled from BSC. The degree of PDCH support in a cell (continuous, on user demand, or no support at all) may be configurable. Information defining the support level and any PDCH, allocated for initiating packet transfer, is broadcasted on a regular GSM Broadcast Control Channel (BCCH). A PDCH is a new type of logical channel on a physical TDMA channel (time slot), optimized for shared packet transfer to and from multiple packet data capable MSs (supporting packet data only, or packet data combined with ordinary voice/circuit data services in different modes of operation). PDCHs are used for data transfer and associated control signalling. A "reservation-Aloha" type of protocol is employed. Uplinks and downlinks are basically used as independent channel resources. In a certain TDMA frame, a PDCH uplink may carry data from one MS and the downlink data to another. The packet data radio link protocol over the PDCH(s) allocated in a cell is handled by a "PD transfer controller" in BTS. In a BTS with at least one PDCH allocated, the PD transfer controller has a, normally unique, physical connection for packet transfer to and from MSC, utilizing ordinary internode trunks.

[0040] In MSC/VLR, a "PD router" is provided for routing packets to and from the MSC service area. Furthermore, a "PD controller" is provided for handling signalling exchange with the "circuit mode MSC", and for han-

dling control, monitoring and parameter storage functions related to packet data MSs. The PD controller comprises processor, memory, signalling interface functions, and software. (Note: Although the PD router and PD controller are described as being provided in MSC/VLR, it should be understood that they, wholly or partly, physically could be realized in the form of external equipment attached to MSC.)

[0041] MSCs (PD routers) are interconnected via a backbone network to which also one or more interworking functions (IWFs) are connected. IWFs provide interworking with external network(s), such as Internet (i.e. IP network) and/or PSPDN (Packet Switched Public Data Network, i.e. X.25 network), thus interconnecting Fixed Stations (FSs) with the MSs. An IWF may perform protocol conversion and address translation, as required. It may also route packet data traffic between co-operating PLMNs. Packet data traffic between MSs in different MSC service areas in the same PLMN is normally routed directly between the respective MSCs, across the backbone network. For routing purposes, HLR may, via a "HLR interrogation server", be interrogated from entities on the backbone network. The HLR interrogation server provides necessary functions to enable such interrogation from the packet data network. HLR, AUC, EIR and OMC, are also enhanced to support the new types of subscriptions, services and equipments.

[0042] The basic packet data network service provided is a standard connectionless network (datagram) service based on a standard connectionless IP protocol. IP is here used to denote the Internet Protocol (the de facto standard IP protocol used in the TCP/IP protocol suite) or the ISO (International Standards Organisation) Internetwork protocol (ISO 8473). (Possibly both these protocols may be supported.) Value-added services, including multicast, broadcast and electronic mail services, may be provided by Network Application Server(s) (NAS(s)), attached to the backbone network and accessed by using higher layer protocols on top of IP. Thus, from a packet data communication point of view, the PLMN basically appears as an IP network. The protocol architecture is illustrated in FIG. 2. The figure shows an example of communication between an MS and a fixed station (FS), e.g. a host computer, attached to an external IP network. IWF and MSC then both have the role of IP (layer 3) routers, and MS and FS may communicate end-to-end using a TCP (Transmission Control Protocol) transport (layer 4) protocol. The MT and TE parts of the MS are in this example integrated in one unit. Between MSC and MS, BTS acts as a link layer (layer 2) relay between the radio link protocol (denoted RL2 in the figure) and the link protocol (denoted L2) used across the trunk connection. The radio protocol handled by BTS is an ARQ (Automatic Repeat reQuest) type of protocol, based on dividing each frame in equal size blocks and retransmitting blocks in error. In contrast to ordinary GSM, encryption/decryption is performed

between MT and MSC. An MS is identified, on layer 3 with an IP address, and on layer 2 with standard GSM identities, International Mobile Subscriber Identity (IM-SI) or, normally, Temporary Mobile Subscriber Identity (TMSI).

[0043] Standard connection-oriented network (X.25) services may also be provided by employing a connection-oriented transport protocol across the PLMN, on top of the IP protocol. An example of transparent X.25 communication between an MS and an FS, attached to an external X.25 network, is shown in FIG. 3. In this example, an X.25 DCE-DTE interface is provided between MT and TE. IWF and MT both perform protocol conversion and map any X.25 virtual circuit on to a transport connection between the two entities, using the intra-PLMN transport protocol (denoted L4). IWF and MT also translate between X.121 and IP address. The L4 protocol may be utilized to provide optional data compression. When a transport connection is established between an MS and IWF, this transport connection is then maintained for the duration of the X.25 virtual call, even if the MS moves to the service area of another MSC. For packets in the mobile originated direction, this is achieved by, as part of the connection establishment procedure, informing the MT of the IP address of the IWF. MT then addresses all packets associated with this connection to this IWF. MSC, in its turn, merely routes packets based on their IP address. In the mobile terminated direction, the IWF is updated with new routing information when the MS moves to a new MSC, as described below. As indicated in the figure, TE and FS may communicate end-to-end via a transport protocol (such as ISO transport, protocol Class 1).

[0044] The packet data services subscribed to are available to an MS after a procedure that brings the MS from an initial GSM idle mode to a new "PD mode". This procedure may be initiated either by the MS making a request for packet data service or by the MSC, currently serving the MS, receiving a packet addressed to the MS. The procedure is based on standard GSM signalling and utilizes standard GSM authentication. The PD mode establishment procedure also includes initiating parameters for packet encryption/decryption in the MS and its current MSC/VLR. After completed procedure, the MS is registered in its current MSC/VLR as being in PD mode. The system then provides access to PDCHs in any cell. It also provides other system mechanisms for fast packet transfer, including:

- Maintaining the authentication granted at PD mode establishment, thus avoiding a time-consuming authentication procedure for normal packet transfers.
- For mobile terminated traffic, mechanisms for establishing and maintaining routes from entities on the backbone network to the MS's current MSC, limiting the need for HLR interrogation to the initial route establishment.

[0045] In PD mode, an MS performs cell selection and location updating based on GSM idle mode procedures. (Handover, in the GSM sense, is not used.) When roaming between cells, the MS, from information broadcasted on BCCH, identifies the PDCH that may be used for initiating packet transfer in a cell. Initiation of packet transfer to an MS from its currently serving MSC is guided by monitoring the MS's cell location based on any previous packet transfer. Depending on the recentness of the cell location information, and on other MS operational parameters (e.g. mobile or stationary mode of operation), the packet transfer may be initiated with or without paging.

[0046] When an MS moves to a location area belonging to a new MSC/VLR, the PD mode registration and any associated information stored at the MS's currently serving MSC/VLR is transferred from the old to the new MSC/VLR. Peer entities of any routes established to the MS's current MSC are also updated with routing information to the new MSC.

I.B Packet Data Mode (PD Mode) and Mobility Management

[0047] PD Mode in relation to regular GSM idle mode and call-connected mode is illustrated in FIG. 4. In this and other figures, the denomination "state" is used as a synonym for "mode". When a packet data MS is turned on, standard GSM power-on and registration procedures are used. After registration, the MS is in attached, idle mode and performs idle mode cell selection and location updating. In order to stay attached to the system, the MS also regularly initiates periodic registration.

[0048] An MS in idle mode may change to PD mode (transition (1) in FIG. 4) by a procedure based on regular GSM signalling and authentication. The procedure may be initiated either by the MS, or by the MSC, currently serving the MS, receiving a packet addressed to the MS. The procedure in the former case is exemplified by the sequence diagram in FIG. 5. Initiation of the procedure may, as determined by a system parameter, be allowed only in cells where a PDCH is allocated or is allocatable on user demand. The signalling sequence (1)-(13) in the figure is based on standard GSM signalling and authentication procedures used for setting up regular GSM voice/circuit data calls. A new type of service request (signal (3)) is used to request PD mode establishment. The optional sequence (8)-(13) is employed to allocate the MS a TMSI (Temporary Mobile Subscriber Identity) and/or to initiate packet encryption/decryption parameters in the MS and its current MSC. After successful completion of the signalling sequence (1)-(13), the MS is registered in its current MSC/VLR as being in PD mode and (optional) encryption parameters are stored (block (14)). The sequence (15)-(17), also based on regular GSM signalling, confirms the PD mode registration and makes the MS change to PD mode. If a PDCH is not already allocated in the cell in question, the PDCH

allocation controller in BSC (FIG. 1) attempts to allocate a PDCH on demand (blocks (18)-(20)). If a channel is available, BSC sends a command to BTS to activate a PDCH and to broadcast channel defining information on BCCH (block (21)). An optional channel defining signal (not shown in the figure) may also be sent directly to the MS, in order to provide a faster notification that a PDCH is allocated. At decision block (22), the MS determines if a PDCH is allocated. If this is the case, the MS may initiate a packet transfer on the defined PDCH. If no PDCH is allocated, the MS may proceed with a predefined procedure, such as periodically initiating a PDCH on demand allocation procedure (described in section I.C below). MSC/VLR is then, via the signal denoted (23), informed that the PD mode establishing procedure is completed. Signal (23) conveys information on the MS's cell location and, optionally, on whether a PDCH is allocated in the cell. This information is stored, linked to the PD mode registration (block (24)). As also indicated in block (24), if PD mode is monitored by a timer and/or inactivity timer, these timers, located in the PD controller (FIG. 1), are initiated.

[0049] The PD mode establishment procedure, described above, is primarily based on ordinary GSM signalling functions, controlled from the circuit mode MSC (FIG. 1), although some adaptations are required e.g. for handling the new type of service request and the new encryption parameters. When PD mode is established for an MS, parameters related to the MS are also transferred to a data base portion of the PD controller. This data base may be regarded as an extension of VLR for packet data MSs. An example of functional division between VLR and this PD controller data base is as follows (alternative realizations are not precluded):

- VLR (as well as HLR) is enhanced with packet data subscription parameters such as IP address, multi-cast address, and timeout parameters. For an MS in idle mode, this information is always available in the current VLR by means of regular location updating procedures (adapted to handle the additional subscription parameters). VLR is also extended with information on whether an MS is in PD mode.
- The PD controller data base provides:
 - a) Storage of operational parameters related to any MS in PD mode, including encryption parameters, timers, cell location, list of peer entities of any routes established, and the MS's current submodes (e.g. mobile/stationary mode, normal/sleep paging mode; see below).
 - b) In order to facilitate fast packet routing and limit the interrogation load of VLR, storage also of a duplicate from VLR of all relevant information stored for any MS in PD mode (including subscription parameters and location area identity).
 - c) To facilitate exchange of signalling informa-

tion with the circuit mode MSC (FIG. 1), capability to, for any packet data MS registered in the MSC/VLR, translate the MS's IP address to IMSI.

d) As a support function to the PD router (FIG. 1), a table with routing information to any MS to which a route is established from the MSC. With the IP address of the MS as input, the table provides routing information to the MS's currently serving MSC.

[0050] Location updating for an MS in PD mode is based on idle mode location updating procedures. When an MS in PD mode moves to a location area belonging to a new MSC/VLR, the new VLR automatically receives the related subscription parameters (from HLR), as part of regular idle mode location updating. The location updating procedure is enhanced such that the new MSC/VLR is informed that the MS is in PD mode, and is provided information on the backbone network address of the previous MSC/VLR. Initiated by the PD controller in the new MSC/VLR, the MS's operational parameters are then transferred (across the backbone network) from the PD controller in the previous MSC/VLR, and the data bases of the two PD controllers are updated. The PD controller in the new MSC/VLR also provides updated routing information to peer entities of any routes established to the MS's current MSC.

[0051] A PD mode establishment procedure may also be initiated when a PD router in an MSC, currently serving an MS in idle mode, receives a packet addressed to the MS. The PD router then signals to the PD controller identifying the destination IP address. The PD controller finds that the MS is not in PD mode and, after translating the IP address to IMSI, requests the circuit mode MSC to initiate a PD mode establishment procedure. As the MS is in idle mode, the request is accepted and the circuit mode MSC initiates the procedure using regular GSM paging, but with a special "PD indicator". The procedure is then very similar to the one described above for the mobile originated case.

[0052] Returning to FIG. 4, the normal situation for an MS in PD mode is that it is located in a cell with at least one PDCH allocated. The first PDCH allocated in a cell, on which packet transfers are initiated, is here designated "Master PDCH" (MPDCH). In this normal situation, the MS performs what is here referred to as "PDCH procedures" (the upper smaller circle in FIG. 4). An MS, using "PDCH procedures":

- a) Performs cell selection based on idle mode procedures:
 - Measures signal strength on current and surrounding cells (when not doing anything else, e.g. between PDCH slots of consecutive TOMA frames), and keeps an updated list of the 6 strongest BCCH carriers.

- In connection with measurements, in order to identify BCCH carriers and read Base Station Identity Code (and TDMA frame number), listens to Synchronization Channel (SCH) of current cell, and Frequency Correction Channel (FCCH) and SCH of adjacent cells.
- In order to read system and cell specific parameters, listens to BCCH and "extended BCCH" (if any) of current cell, and BCCH of adjacent cells.

[0053] Thus, the available framework for regular GSM broadcast control channels are utilized for performing cell selection. In the MS, the cell selection criteria may be somewhat modified compared to idle mode, if a user (e.g. with a keyboard command) selects to operate the MS in "stationary mode". In stationary mode, the MS retains the current cell as long as the signal quality is above a certain threshold value. The purpose is to reduce the probability of "unnecessarily" changing cell due to fluctuations in the radio environment, e.g. caused by reflections from moving objects. If the signal quality falls below the threshold value, the MS automatically returns to normal "mobile mode" of operation. The MS informs the PD controller in its currently serving MSC/VLR of its mode of operation, by sending a mobile/stationary mode indicator at least every time it changes from mobile to stationary mode, or vice versa. For data transfer to an MS in stationary mode, paging may then be limited to a single cell, or data may be sent directly (as "immediate data" / "immediate channel reservation" followed by data) without previous paging.

[0054] In an alternative realization of the embodiment, the modified cell selection criteria may be employed also for an MS in mobile mode. Provided that the information on the MS's cell location (stored in the PD controller) is sufficiently recently updated, packet transfer to the MS may be initiated in a similar way as to a "stationary" MS.

b) Listens to MPDCH and performs packet transfers as required. On MPDCH, an MS listens for:

- Paging, in "normal" paging mode (during a period of relatively high packet transfer activity) or "PD sleep" paging mode.
The MS, explicitly or implicitly, informs the PD controller in its current MSC/VLR of its paging mode, by sending a normal/PD sleep mode indicator at least every time it changes paging mode.
- "Immediate data" (or "immediate channel reservation" followed by data) without previous paging, in normal mode.
- PDCH broadcast messages (i.e. unacknowledged messages to all MSs in a cell), in normal or PD sleep mode.
- Multicast messages (i.e. unacknowledged messages addressed to a group of MSs), in

normal or PD sleep mode. c) Optionally, listens to GSM cell broadcast short messages (SMS).

[0055] Coordination of the above procedures may be accomplished by employing for the MPDCH downlink a multiframe scheme similar to and synchronized with the 51-frame multiframe schemes used for regular GSM downlink control channels. Compared to idle mode, when an MS may listen to broadcast channels at any time except during its assigned (sleep mode) paging block, more extensive coordination is required for an MS in PD mode, and specifically when the MS is in normal paging mode. In the latter case, the time an MS is available for downlink messages needs to be maximized, while allowing sufficient time for the broadcast listening tasks. A multiframe coordination scheme with this purpose is exemplified in FIG. 6 and FIG. 7. FIG. 6 shows an example of a 51-frame MPDCH multiframe, synchronized with the corresponding GSM Broadcast Channel (BCH) / Common Control Channel (CCCH) and Stand-alone Dedicated Control Channel (SDCCH) multiframes. As depicted in FIG. 7, 8 MPDCH multiframes form a multiframe cycle (synchronized with the corresponding BCH/CCCH and SDCCH multiframe cycles). FIG. 7 also illustrates an example of scheduling adequate times for the tasks of listening to and reading information from ordinary GSM broadcast channels.

[0056] The MPDCH multiframe (FIG. 6) comprises:

- Paging blocks (similar to GSM), marked P0-P7, each 4 TDMA frames long.

[0057] In PD sleep mode, an MS listens to one of the paging blocks (depending on its IMSI) in a subset of the multiframes in the cycle, as determined by a system parameter (giving a sleep mode period ranging between approximately 0.25 and 2 seconds). Multiframes 5 and 7 every Nth cycle are excluded, as these (as illustrated in FIG. 7) are scheduled for listening to adjacent BCCH.

[0058] In normal mode, an MS may be paged in all paging blocks, and at any time not scheduled for other purposes (see below). The same is true for "immediate data" / "immediate channel reservation".

- A block marked PDB, used for PDCH broadcast (with the exceptions indicated in FIG. 7).

[0059] PDCH broadcast may, with a sleep mode parameter, be limited to a defined subset of the multiframes. The sleep mode parameter may be different from that used for paging.

[0060] PDCH broadcast is used for providing system information, including PDCH specific parameters, and a flag indication when relevant information on current BCCH has changed. MSs should then read BCCH and "extended BCCH" (if any), starting with the next multiframe and until the relevant information contents of all 8 multiframes have been read (see FIG. 7). PDCH

broadcast may also be used for different kinds of user information services.

- Frames marked F0-F14 which can be grouped in different ways for various purposes (see FIG. 7).

[0061] Furthermore, the block F3-F6 may (when not allocated for other purposes; see FIG. 7) be utilized for multicast messages. (Other multicast allocation alternatives exist.)

[0062] The BCH/CCCH multiframe is included in FIG. 6 to show the allocation of FCCH (marked F), SCH (marked S), and BCCH (marked B) used in the cell selection process. "Extended BCCH" (if provided) is allocated in the first "C" block from the left, in multiframes 4-7 (see FIG. 7). The purpose of showing the SDCCH multiframe in FIG. 6, is to indicate the allocation of cell broadcast SMS. These are allocated a subchannel utilizing the block marked "D2", in multiframes 0-3 (as shown in FIG. 7). A possible way to schedule listening to these broadcast channels is shown in the diagram of FIG. 7. The more precise block/frame allocation in the respective multiframe is defined in the column at the right hand side.

[0063] As indicated in FIG. 7, for listening to FCCH and SCH of adjacent cells, opportunities are provided twice per cycle (i.e. approximately once per second). As the multiframes of adjacent cells may be unsynchronized with those of the current cell, 12 consecutive frames need to be assigned.

[0064] An MS that needs to read information from BCCH of an adjacent cell, should read at least one BCCH block from multiframes 2, 3, 6 or 7 in a multiframe cycle. This is achieved with the reading schedule in FIG. 7, again taking into account that multiframes of adjacent and current cells may be unsynchronized. The time indicated for reading adjacent BCCH is assigned once every N:th cycle, where N is a system parameter.

[0065] In some situations, an MS in PD mode temporarily has to be "off PDCH" and use ordinary GSM channels and perform what is here denoted "GSM procedures". It is then accessible by and has access to the same signalling as in idle mode. It also performs cell selection exactly as in idle mode. Common situations when the MS changes to these "GSM procedures" (transition marked (3) in FIG. 4) are:

- a) When the MS moves to a new location area. It then performs location updating based on idle mode procedures. Upon completion, the MS returns to "PDCH procedures" (transition (4) in the figure).
- b) At regular intervals, when the MS performs periodic registration as in idle mode. Upon completion, the MS returns to "PDCH procedures" (transition (4)).
- c) When the MS (on PDCH) receives a request from its current MSC to perform authentication or equipment identification. The requested procedure is

then performed in an essentially regular GSM manner. After granted and completed procedure, the MS returns to "PDCH procedures" (transition (4)). If the authentication or equipment identification is rejected, the procedure ends with the MS receiving a "PD mode termination command", returning the MS to idle mode (transition (5)).

d) When the MS moves to a cell where no PDCH is allocated but where a PDCH may be allocated on user demand. In such a cell, the MS may be paged via ordinary GSM paging channel.

Depending on system configuration (operator's choice), the MS may be required to report to its current MSC/VLR when it moves from a cell with PDCH allocated to one without, and vice versa. This information is stored in the PD controller (FIG. 1) which thus monitors the procedures used by the MS. In this case, paging is made on either MPDCH or ordinary GSM paging channel. In a system where the PD controller does not have this information, paging has to be made in parallel on both MPDCH and ordinary GSM paging channel, if the paging area comprises cells of both kinds.

A PDCH may be allocated when an actual need for packet transfer arises as described in section I. C below. The MS returns to "PDCH procedures" (transition (4)) when a PDCH is allocated, or when the MS moves to a cell with PDCH allocated.

e) When the MS moves to a cell not supporting PDCH. This case is similar to d) above with the difference that no PDCH may be allocated. Moreover, packet data paging (using ordinary GSM paging channel) may or may not be made in this type of cell, depending on system configuration.

[0066] For a combined MS, supporting both packet data and ordinary GSM services (but not simultaneously), a number of mixed traffic situations are possible. An MS in PD mode may make or receive a regular GSM (voice/circuit data/point-to-point short message) call with the PD mode maintained as "pending" during the call and returned to "active" when the call is completed. To make a call, the MS, if it was using "PDCH procedures", first changes to "GSM procedures" (transition (3) in FIG. 4). When using "GSM procedures", the MS initiates a call in a regular GSM manner and, when the call is set up, changes to call-connected mode (transition (6)). Via the circuit mode MSC (FIG. 1), the PD mode is marked as "pending" in VLR and in the data base portion of the PD controller (FIG. 1). When the call is completed, the MS returns to "active" PD mode (transition (7) in FIG. 4) and is marked accordingly in VLR and the PD controller.

[0067] If an ordinary GSM call to an MS in PD mode is received by a circuit mode MSC, the circuit mode MSC, after finding from VLR that the MS is in PD mode, requests the PD controller to initiate paging of the MS. If the PD controller has information on the procedures

used by the MS, paging is initiated accordingly using either MPDCH, for which special paging types are provided to convey GSM calls, or ordinary GSM paging channel (via the circuit mode MSC). Should such information not be available in the PD controller, paging may involve both types of channels in different cells. If the MS indicates "accept" in its paging response, the call, after the MS having changed to "GSM procedures" as required, is set up and PD mode is kept "pending" during the call in a similar way as described above for a mobile initiated call.

[0068] If a packet, addressed to an MS in GSM call-connected mode, is received by a PD router (FIG. 1), the associated PD controller, finding that the MS is not in PD mode, requests the circuit mode MSC to initiate a PD mode establishment procedure as described above. However, as the MS is in call-connected mode, the request is rejected. This may result in the PD router sending an upstream error report, indicating that the MS is unreachable. In a similar situation when the MS is instead in "PD pending mode", the result is almost the same. The difference is that the circuit mode MSC does not need to be involved, as the MS mode information is available in the PD controller. For an MS subscribing to mail service, the message delivery in these and similar situations may be deferred until the MS becomes available.

[0069] As indicated above, PD mode for an MS may be monitored by a timer and/or inactivity timer, handled by the PD controller in the MSC/VLR currently serving the MS. When PD mode is established, each timer provided is initiated to count a predetermined period of time (timeout period). The inactivity timer is reset and reinitiated for any packet received from or sent to the MS. The time out periods may be subscription parameters. Termination of PD mode and return to idle mode (transition (2) in FIG. 4) may be initiated by a termination request from the MS, or by a termination command from the PD controller when a timeout occurs.

[0070] If a periodic registration is not received as required from an MS in PD mode, the PD mode is terminated, by first changing the MS mode to idle (transition (2)), and then marking the MS as "detached" in VLR according to ordinary idle mode procedures. An MS wishing to initiate an explicit "detach", first initiates a change to idle mode (transition (2)) and then sends an "IMSI detach" as an idle mode.

[0071] When PD mode is terminated, peer entities of any routes established are informed and the routes are terminated.

[0072] Some additional mobility management aspects related to mobile terminated packet transfer are described in section I.D.

I.C Provision of Packet Data Channels (PDCHs)

[0073] The main function blocks involved in providing PDCHs are (see FIG. 1):

- The transceivers in BTS which are enhanced with capability to:
 - Dynamically change the configuration of any physical channel (time slot) from regular GSM traffic channel TCH to PDCH, and back to TCH, on PDCH allocation/PDCH release command respectively from the PD transfer controller.
 - When frequency hopping is employed, adapt PDCH(s) to comply with the hopping sequence used.
- The PD transfer controller in BTS which is processor-based and comprises both software and hardware. It:
 - Controls allocation/release of PDCHs on command from the PDCH allocation controller in BSC.
 - Controls packet transfers and handles the radio link protocol for PDCH(s) allocated, in accordance with the multiframe coordination scheme (described in section I.B).
 - As part of a dynamic channel allocation process, monitors traffic load on PDCH(s) and generates PDCH allocation/PDCH release requests to the PDCH allocation controller in BSC, as required.
- The PDCH allocation controller in BSC which is processor-based and comprises both software and hardware. Together with the "circuit mode BSC", which has the overall responsibility for radio channel resources, it coordinates allocation of PDCHs such that, from a common pool of physical channels (time slots), a variable mix of TCHs and PDCHs may be allocated determined by demand. In this process, the PDCH allocation controller:
 - Collects requests for PDCH allocation/PDCH release and conveys the requests to the circuit mode BSC.
 - Receives commands for PDCH allocation/PDCH release from the circuit mode BSC and conveys the commands to the PD transfer controller in BTS.
 - Supplies the information that on a per cell basis defines the degree of PDCH support provided and the MPDCH allocated (if any), and that is broadcasted on BCCH by the respective BTS.

[0074] In addition, interface functions and some common control functions in BTS are adapted to support the new PD functions (FIG. 1).

[0075] The first PDCH in a cell (the "master PDCH" MPDCH), that is capable of carrying the necessary control signalling for initiating packet transfer as well as packet data and that is defined by cell specific informa-

tion on BCCH, may be allocated either by system configuration or on user demand. "PDCH on demand" support may be of particular interest in a low capacity (e.g. single carrier) cell, only occasionally visited by a packet data user.

[0076] In a "PDCH on demand cell", an MPDCH may be allocated when an actual need for packet transfer arises:

a)When PD mode is established for an MS (located in the cell), an MPDCH is allocated (if a channel is available) as the last part of the PD mode establishment procedure as described in section I.B. The PDCH allocation is initiated by a command from the circuit mode BSC to the PDCH allocation controller.

b)When an MS in PD mode (located in the cell) has data to send, it makes a "PDCH allocation request" using "GSM procedures" as illustrated in FIG. 8. The signalling sequence (1)-(4) is based on standard GSM signalling with the addition of a new type of service request (signal (3)). The service request is received by the circuit mode BSC which, if a channel is available, generates a PDCH allocation command to the PDCH allocation controller. An MPDCH is then allocated (block (6)) and channel defining information is broadcasted on BCCH (block (7)). An optional channel defining signal (not shown in the figure) may also be sent directly to the MS, in order to provide a faster response. At decision block (8) the MS determines if a PDCH is allocated. If this is the case, it may proceed with initiating a packet transfer on the defined MPDCH. If no PDCH is allocated, the MS may proceed with a predefined procedure, such as periodically repeating the PDCH allocation request.

c)When a packet addressed to an MS in PD mode (located in the cell), is received by the MS's currently serving MSC/VLR, an MPDCH is allocated (if a channel is available) if the following paging, using GSM paging channel, results in a positive paging response. With the addition of an initial paging, the procedure is very similar to the one described above for the mobile originated case.

d)In a situation when an MS, in PD mode and located in an adjacent cell where PDCH is allocated, has a data communication session in progress or has data ready to send immediately prior to moving into the "PDCH on demand cell", it may initiate a "PDCH allocation request" for the new cell, using the MPDCH in the currently serving cell. The request is transferred to the PD controller in MSC/VLR, from which it is forwarded to the PDCH allocation controller in BSC, and from there to the circuit mode BSC. If the request is granted, the MS may not need to change to "GSM procedures".

[0077] When a first PDCH (MPDCH) has been allocated, additional "slave PDCHs" (SPDCHs) may be al-

located depending on traffic load:

- Either semi-permanently (e.g. different mix of PDCHs and GSM traffic channels TCHs at different times of the day).
- Or dynamically adapted to the current load situation.

[0078] In case of multiple PDCHs allocated to a cell, the PDCHs may be used as a set of "trunked" channels utilizing a dynamic assignment protocol. MPDCH is then used for access control signalling (including channel request, channel reservation and paging) and, as far as capacity admits, data, whereas SPDCH(s) are used for reserved data transfer.

[0079] Furthermore, in a situation when the MPDCH becomes a bottleneck, it is possible to allocate one or more additional MPDCHs such that a group of (m) MPDCHs may be used together with a group of (s) SPDCHs. Each MS is then assigned to a particular MPDCH determined by an algorithm based on the MS's identity (IMSI) and on control information broadcasted on BCCH and/or one or more of the MPDCHs.

[0080] The process of dynamically allocating/releasing PDCH(s) in a cell is based on measuring throughput and comparing with predetermined limits as illustrated in FIG. 9. The upper dotted part of the flowchart illustrates allocation of a first MPDCH either on demand or as a result of system configuration. At block (1), the counts of allocated MPDCHs (m) and SPDCHs (s) are initiated.

[0081] At block (2), the average throughput across MPDCHs is measured (in BTS) over predetermined period(s) of time. At block (3), it is determined if an upper limit (measured over an associated "upper limit period of time") or a lower limit (measured over an associated "lower limit period of time") is reached.

- If no, the monitoring process proceeds.
- If the upper limit is reached and if, as in this example, no SPDCH is allocated (s=0), BTS sends an SPDCH allocation request to BSC (block (17)). BSC determines if a channel is available (block (18)).
- If yes: Initiated from BSC, an SPDCH is allocated in BTS (blocks (19) and (20)). The packet data protocol scheduling in BTS is readjusted to the new PDCH configuration (block (14)). The process then proceeds with throughput measurements across MPDCH(s) (block (2)) and in a similar way across SPDCH(s) (block (15)).
- If no: A check is made whether the frequency of rejected channel allocation requests indicates a permanent overload condition (block (23)). In that case, a predetermined procedure for reporting/resolving the problem is initiated (block (25)). Otherwise, the traffic load is tem-

porarily limited by (in BTS) readjusting flow control parameters (block (24)). The cycle is then repeated, starting at block (2).

- If the lower limit is reached (at block (3)), BTS sends an MPDCH release request to BSC. After notifying MSs by means of broadcast information (block (10)), an MPDCH is released (blocks (11) and (12)). If, as in this example, it is found (at block (13)) that this was the only MPDCH, the process proceeds at point (A) with monitoring any request or command for a new MPDCH allocation.

If, in another case, it is determined at (block (13)) that at least one MPDCH is still allocated, the process, after readjustment of the packet data protocol scheduling at block (14), proceeds at point (C).

[0082] Although a particular example has been described, it should be understood from the flow chart that the process of dynamically allocating/releasing PDCH (s) applies for any given configuration of MPDCH(s) and SPDCH(s).

I.D Packet Transfer Within an MSC Service Area

[0083] Packet transfer between the PD router in MSC/VLR (FIG. 1) and MSs in the MSC service area is to a large extent determined by the radio link (layer 2) service provided by PDCHs. Variable length packets up to some maximum size (such as approximately 600 octets, depending on the PDCH protocol) from layer 3 are accepted by the layer 2 entity in the PD router and by the MT part of MSs respectively. Each packet, normally after encryption, forms the information field of a layer 2 frame. Across the radio link (between BTS and MT), each frame is divided into fixed size blocks (of approximately 25 information octets, corresponding to 4 TDMA bursts). For each block, BTS or MT respectively performs channel coding, burst formatting, and interleaving (per block). A selective repeat type of ARQ protocol between BTS and MT then provides retransmission of blocks in error.

[0084] The TDMA structure and the need to allow for the same degree of timing disalignment at first MS access as in ordinary GSM have lead to the selection of a "reservation-Aloha" type of protocol. To initiate a packet transfer in the mobile originated direction, illustrated by the sequence diagram in FIG. 10, an MS makes a random access request (signal (1) in the figure) on the MPDCH uplink (using the same type of access burst as in ordinary GSM), when allowed to do so, as determined by "uplink state flags" (USFs) on the MPDCH downlink. The access burst includes a random number providing an initial identification of the MS, and may also include class of service type of information.

[0085] BTS normally responds with a channel reservation command (signal (2)) on the MPDCH downlink, reserving channel capacity for uplink data transfer and

downlink acknowledgement (ACK). (In case of no response from BTS, the MS makes a retry after a random backoff time.) The channel reservation command includes the same random number as received in the access burst, and timing alignment/power control (TA/PC) commands. The timing alignment/power control functions are performed in BTS, not only the measurements part (as in ordinary GSM) but also, for performance reasons, the processing and command generation parts (located in the PD transfer controller).

[0086] The data frame (signal (3) in the figure) from the MS is followed by a positive acknowledgement (signal (4)) from BTS (as no retransmissions are assumed in this example), and the frame is relayed to the PD router in MSC/VLR. Here, the MS's cell location is determined by associating the frame (which includes the MS's identity TMSI in the frame header) with the (for each cell unique) physical connection on which the frame is received. In an alternative realization, the MS's cell location may be identified by providing in the PD transfer controller in BTS the additional function of inserting a cell identifier in the frame header, in a similar way as described in the cited US.A-4,916,691. The cell location identity and the associated time when the frame was received are, together with MS parameters (such as mobile/stationary indicator, class of service) that may be conveyed in the frame header from BTS, stored in the PD controller data base, linked to the MS's identity. The packet, normally after decryption, is then available at the layer 3 entity of the PD router for routing to the destination (in the example in FIG. 10 via an IWF).

[0087] When a packet, addressed to an MS is received by the PD router in the MSC/VLR where the MS is registered and it is found from the data base in the PD controller (FIG. 1) that the MS is in PD mode, the packet is first fragmented, as required, to match the maximum packet size across PDCHs. The way the packet transfer to the MS is initiated then depends on the MS operational parameters available in the PD controller data base:

- Cell location and recentness of the information
- Mobile or stationary mode of operation
- Normal or PD sleep paging mode
- "PDCH" or "GSM procedures" used (depending on system configuration, as described in section I.B)

[0088] Based on this information, the PD controller uses a software algorithm to select method for initiating the packet transfer:

a) Transferring the data frame directly to a specific BTS (without previous paging).

[0089] This method is used if the MS is in stationary mode. It may be used also when the MS is in mobile mode, provided that the modified cell selection criteria employed in stationary mode (described in section I.B)

is employed also for MSs in mobile mode, and provided that the cell location information is sufficiently recently updated.

[0090] The frame header in the transfer to BTS includes TMSI, an indicator of the MS's paging mode, IMSI (if the MS is in PD sleep mode), and possible class of service information. If the MS is in PD sleep mode, BTS then initiates the data transfer across PDCH(s) using paging (in a single cell). Otherwise, the data transfer is initiated with "immediate channel reservation", or data may be sent directly as "immediate data" on MPDCH.

[0091] An "immediate channel reservation" transfer sequence is exemplified in FIG.11. The channel reservation (signal (5)) on the MPDCH downlink informs the MS of the channel on which the data frame (signal (6)) is to be received. If the data transfer takes place on an MPDCH, channel reservation may not be needed. The data frame includes reservation of an access slot on the MPDCH uplink for the MS to respond. In the response burst (signal (7)), one bit is allocated for acknowledging the data frame. If, as in the example, the acknowledgement is positive, the sequence is completed. In case of a negative acknowledgement, BTS sends a channel reservation for a more specified negative acknowledgement from the MS (defining blocks to be retransmitted), and for retransmission from BTS. This channel reservation also includes TA/PC commands. The retransmission then includes channel reservation for the MS to acknowledge and for a possible further retransmission.

b)Paging over a group of cells

[0092] To economize on spectrum, paging is limited to the smallest possible group of cells based on available cell location information. Paging is initiated by a "high level command" (including information on IMSI, TMSI, location area, cell location and recentness of this information, and paging mode) from the PD controller to the PD signalling controller (FIG. 1) in affected BSC(s). (Alternative divisions of paging functions between MSC and BSC are not precluded.) As described in section I. B, depending on system configuration, the paging may include paging on both MPDCH and ordinary GSM paging channel and may thus involve also the "circuit mode" portion of BSC(s).

[0093] In a situation when the probable cell location can be limited to a small group of cells, a special type of paging message may be employed which combines paging with reservation of an access slot for the MS to respond. An example of using this type of paging is shown in the sequence diagram in FIG. 12. With the signal marked (5) in the figure, the paging command initiated by MSC reaches BTS. The PD transfer controller in BTS then generates a paging message (signal (7)) on the MPDCH downlink which includes reservation of an access slot on the MPDCH uplink for the MS to send a response burst (signal (8)). The paging response (signal (9) and (12)) transferred back to MSC includes in-

formation on the MS's cell location, which information (with the associated time when the paging response was received) is stored in the PD controller data base. The paging response also results in a channel reservation (signal 10)) on the MPDCH downlink for the data transfer. The channel reservation also includes TA/PC commands. When data is received from MSC (signal (13)), it is transferred on the reserved PDCH downlink (signal (16)). Channel reservation for an acknowledgement from the MS (signal (17)) and for possible retransmission may either be combined with the data frame (signal (16)) or included in the initial channel reservation (signal (10)).

[0094] When this type of paging is used to convey an ordinary GSM call, one bit in the response burst is allocated to indicate "accept" or "reject" to the call, after which the sequence is completed.

[0095] The advantage with this type of paging, that includes reservation of an access slot for a paging response burst, is that the response can be uniquely identified in spite of the fact that it only comprises 8 bits of information. In this way, the sequence can be considerably shortened compared to ordinary GSM paging, which is of importance considering packet transfer delays. However, this type of paging is spectrum efficient only when used over a small group of cells.

[0096] As minimization of the total usage of radio channel resources for location updating/cell location reporting on one hand, and paging on the other, is crucial for spectrum efficiency, some complementary mechanisms may be needed for MSs in PD mode. These may include the use of smaller location areas than in regular GSM and/or, under certain conditions, cell location reporting from MSs.

[0097] Concerning timing alignment/power control, the need for renewal within a certain period of time imposes restrictions on maximum packet size. For example, the TA/PC commands included in the channel reservation (signal (10)) in FIG. 12 should, with a maximum size packet in the data frame (signal (16)), allow adequate timing alignment and power control at least until the acknowledgement (signal (17)) is received from the MS. A maximum packet size of approximately 600 octets, should provide sufficient margins. As required, additional TA/PC commands (as well as channel reservation commands) may be included in later parts of a sequence, combined with negative acknowledgement(s) or retransmission(s).

[0098] The principles for the mentioned uplink state flags (USFs) and for the type of paging that reserves an access slot for the MS to respond are illustrated by the examples in FIG. 13. The series of slots that depict MPDCH downlink and uplink respectively represent time slots in consecutive TDMA frames. The figure shows two simple transfer examples, one mobile originated (with index 1) and one mobile terminated (with index 2). All control messages (except access bursts) comprise one block (i.e. 4 bursts). An USF on the MPDCH down-

link marks a corresponding access slot on the MPDCH uplink as either "free" (for random access) or "reserved". In this example, USFs are coded individually per MPDCH downlink burst (by allocating a group of redundant bits, carrying one bit of information, for this purpose). An USF in TDMA frame n governs access in TDMA frame $n + m$. In this example, $m = 1$.

[0099] The mobile originated data transfer starts with a random access burst from mobile station MS 1 in an access slot that is marked as "free" by an USF. BTS responds with a channel reservation command on the downlink and changes USF to "reserved" for the duration of the subsequent uplink data transfer. A downlink acknowledgement then completes the transfer sequence.

[0100] The mobile terminated transfer is initiated by a paging message to mobile station MS 2 providing the MS a reserved slot for its response burst. The paging response is followed by a channel reservation command and a subsequent downlink data transfer. After an acknowledgement from the MS in a reserved uplink block, the sequence is completed.

[0101] A paging message may include paging of more than one MS and then includes reservations of individual access slots for the MSs to respond. The reservations may be explicit (in the form of pointers) or implicit, in which case the next few reserved slots are allocated to the MSs in the order they appear in the paging message.

[0102] The described principle for access slot reservation may be used also in the "immediate channel reservation" example above.

[0103] USFs may alternatively be included in the block channel coding and interleaving, and thus be provided on a per block basis. After receiving a block, an MS then knows the USFs (which may still be associated with individual access slots) for the 4 following access slots.

I.E Packet Routing To and From MSC Service Areas

[0104] Routing of packets from entities on the backbone network (FIG. 1) to an MS in PD mode is, as mentioned, based on establishing and maintaining routes to the MS's currently serving MSC, by means of:

- From initiating entities, initially interrogating HLR, via the HLR interrogation server.
- In the PD controller data base in the MS's current MSC/VLR, storing a list of peer entities of any routes established, linked to the MS's PD mode registration.
- When the MS moves to a location area belonging to a new MSC/VLR, transferring the list of peer entities (and other parameters related to the MS) from the old to the new MSC/VLR, and updating the peer entities with routing information to the new MSC.

[0105] To be able to provide the necessary routing information, HLR is enhanced to provide, at the initial interrogation when a route is being established, the IP address of the MSC currently serving the MS in question. HLR is informed of this IP address by means of an extension, for packet data MSs, of the procedure used when an MS registers in an MSC/VLR. The information sent from MSC/VLR to HLR at registration is then extended to include the MSC's IP address.

[0106] Furthermore, each route may be monitored by an inactivity timer, handled by the PD controller in the MSC/VLR currently serving the MS. When the route is established, the inactivity timer is initiated to count a predetermined period of time (timeout period). The inactivity timer is reset and reinitiated for any packet received from the route, addressed to the MS. The timer is reset and reinitiated also for any packet from the MS to the route, when the route is a bidirectional route between the MS's current MSC and another MS's current MSC, linked to the two MSs' respective PD mode registrations. The timeout period may be a subscription parameter. When a timeout occurs, the peer entity is informed and the route is terminated.

[0107] The method used for routing packets in the mobile terminated direction to an MS's currently serving MSC depends on the IP addressing scheme chosen for the packet data PLMN. If the addressing scheme is such that the network identifying portion of an MS's IP address identifies the MS as belonging to a particular PLMN, or subdomain of a PLMN including a group of MSCs, the routing method illustrated by the example in FIG. 14 may be used. Referring to the sequential steps indicated in the figure:

- 1) IWF 1 receives a packet addressed to MS 1.
- 2) As required, IWF 1 performs protocol conversion and address translation (from the external network to the intra-PLMN IP network). The address translation data base may be available locally at the IWF or via remote access. When a route has been established for an MS, the address translation is performed locally.

IWF 1 determines, from an internal data base that stores routing information for any MS for which a route is established, if a route is established to MS 1's current MSC. If a route is established, the sequence proceeds with 7). Otherwise, it proceeds with 3).

3)-4) IWF 1 interrogates HLR via the HLR interrogation server.

5)-6) The response from HLR includes the IP address of MS 1's current MSC (MSC 2).

7) The packet is encapsulated with MSC 2's IP address as destination address and IWF 1's IP address as source address. The encapsulated packet is routed to MSC 2.

8) The packet is decapsulated and address information is analysed by the PD router and PD con-

troller in MSC/VLR 2 respectively (FIG. 1). The PD controller determines if MS 1 is in PD mode.

- If no: A PD mode establishment procedure is initiated (described in section I.B). 5
- If yes: The PD controller determines if a route from IWF 1 (IWF 1 being identified by the source address in the encapsulated packet) is established for MS 1 (i.e. if IWF 1 is included in the list of peer entities linked to MS 1). 10

If yes: If the route is monitored by an inactivity timer, the timer is reset and reinitiated. The sequence then proceeds with transferring the packet to the MS (as described in section I.D).

If no: The IP address of IWF 1 is stored (linked to MS 1's identity), indicating that a route is being established. If the route is to be monitored by an inactivity timer, the timer is initiated. The sequence then proceeds with 9). 15

9) MSC 2 notifies IWF 1 that a route segment is established.

10) IWF 1 acknowledges.

11) IWF 1 stores (linked to MS 1's identity) the IP address of MSC 2 (MS 1's current MSC). 25

[0108] When the PD router in an MSC/VLR (MSC/VLR 1) receives a packet instead originated from an MS (MS 1) within the MSC service area, the network identifying portion of the destination IP address is first analysed. If the destination address is not within the range of addresses assigned to MSs belonging to the PLMN, the packet is routed according to normal IP routing rules. If, on the other hand, the destination address is within this range of addresses and thus belongs to an MS (MS 2), the "extended VLR data base" in the PD controller is interrogated. With the above mentioned addressing scheme, the routing method may then comprise the following steps: 30

1)The PD controller (in MSC/VLR 1) determines if a route is established to MS 2's current MSC, linked to MS 1's PD mode registration (and to MS 2's identity). 35

- If yes: If the route is monitored by an inactivity timer, the timer is reset and reinitiated. The packet is then either transferred to MS 2, if MS 2 is registered in the same MSC (MSC 1), or routed to MSC 2's current MSC using the encapsulation technique described above. 50
- If no: The sequence proceeds with 2).

2)The PD controller checks if a route is established to MS 2's current MSC, linked to any of the other MSs registered in MSC/VLR 1. 55

- If yes: The packet is either transferred to MS 2,

if MS 2 is registered in the same MSC (MSC 1), or routed to MS 2's current MSC using the encapsulation technique described above. MS 2's current MSC then initiates establishment of a (bidirectional) route between the two MSs' current MSCs, linked to their respective PD mode registrations. If the route is to be monitored by inactivity timer(s) (at one or both ends of the route), the timer(s) are initiated.

- If no: The sequence proceeds with 3).

3)The PD controller determines if MS 2 is registered in MSC/VLR 1.

- If yes: As required, a procedure for establishing PD mode for MS 2 is initiated. If or when PD mode is established, a (bidirectional) route is established as a linkage between the two MSs' respective PD mode registrations. In this way, the route between the two MSs' respective current MSCs can be maintained if any of the MSs moves to another MSC/VLR.

(Inactivity timer(s) are, when applicable, initiated as in 2) above).

- If no: The sequence proceeds with 4).

4)The PD controller initiates a procedure, including HLR interrogation, for establishing a route to MS 2's current MSC, in a similar way as in the above example of route establishment from an IWF. If successful, the procedure ends with a (bidirectional) route being established between the two MSs' respective current MSCs, linked to their respective PD mode registrations. 35

[0109] In another possible addressing scheme, the network identifying portion of an MS's IP address identifies the MS as belonging to a specific MSC/VLR. Routing of packets in the mobile terminated direction may in this case be based on the method exemplified in FIG. 15. The sequential steps indicated in the figure are as follows: 40

1)IWF 1 receives a packet addressed to MS 1.

2)As required, IWF 1 performs protocol conversion and address translation in a similar way as described for the example in FIG. 14. (For an "active" MS, the address translation is performed locally.)

3)The packet is routed based on its destination address (as a normal IP packet). In this example, MS 1 is assumed to have an IP address belonging to the set of addresses assigned to MSC 1. Thus, the packet is routed to this "predetermined MSC".

If the external network is an IP network, particular IWFs may not be needed with this addressing scheme. The backbone network may then be a part of the "external network", and packets may be routed directly to the respective MSC, based on desti-

nation address.

4)The PD controller in MSC 1 determines if a route is established to MS 1's current MSC (even if, at the moment, the current MSC should be the same as the "predetermined MSC 1"). If a route is established, the sequence proceeds with 9). Otherwise, it proceeds with 5).

5)-13) In this example (as MS 1 is currently registered in MSC/VLR 2), the PD controller finds that MS 1 is not registered in MSC/VLR 1. It therefore initiates a procedure for establishing a route to MS 1's current MSC (MSC 2), in the same way as described for the example in FIG. 14. The procedure includes HLR interrogation (steps 5)-8) in the figure), and routing of an encapsulated packet to MSC 2 (step 9)).

[0110] When, with this second addressing scheme, the PD router in an MSC/VLR (MSC/VLR 1) receives a packet instead originated from an MS (MS 1) within the MSC service area, and the destination IP address is found to be within the range of addresses assigned to MSs belonging to any of the MSC/VLRs in the PLMN, the routing method may comprise the following steps:

1)The PD router determines if the destination address (the IP address of a mobile station MS 2) "belongs to" MSC/VLR 1.

- If yes: Routing is then performed in the same way as described for the example in FIG. 15 (as required, including route establishment to MS 2's current MSC).
- If no: The sequence proceeds with 2).

2)The PD controller checks if MS 2 is currently registered in MSC/VLR 1.

- If yes: After PD mode establishment, as required, the packet is transferred to MS 2.
If no: The sequence proceeds with 3).

3)The packet is routed based on its destination address, to the "predetermined MSC" to which MS 2 belongs from an addressing point of view. Routing is then performed in the same way as described for the example in FIG. 15.

[0111] Thus, with the second addressing scheme, all packets to an MS, originating from entities outside the MS's current MSC service area, are routed via the MS's "predetermined MSC". It may therefore be advantageous to (optionally) initiate establishment of a route from the "predetermined MSC" to the MS's current MSC also when the PD router (in the MS's current MSC) receives a packet from the MS. Then, if it is found that the packet is not addressed to an MS located within the MSC service area, and that the mentioned route is not

already established, the PD controller may initiate route establishment by:

- Determining the IP address of the MS's "predetermined MSC", based on the network identifying portion of the (originating MS's) IP source address and stored routing information.
- Initiating signalling to the "predetermined MSC" to establish the route.

[0112] In this way, HLR interrogation for any subsequent response packet (e.g. in query/response type of applications) can be avoided.

[0113] Another case, where it may be advantageous to initiate establishment of a route to an MS's current MSC based also on the MSC receiving a packet from the MS, applies to a PLMN that provides connection-oriented (X.25) network services between MSs and an external X.25 network, and that employs an addressing scheme of the first type described above. In this case, when the PD router, in an MS's current MSC, from the MS receives a packet carrying a "transport connection request" (e.g. identified by a "class of service identifier" in the frame header), the X.25 IWF to which the packet is to be routed is determined based on stored routing information. If this IWF is not already on the list of peer entities from which routes are established, linked to the MS's PD mode registration, the packet is "encapsulated" (with the IWF's IP address as destination address and the MSC's IP address as source address) and routed to the IWF. This initiates establishment of a route from the IWF to the MS's current MSC. HLR interrogation can thus be avoided for the response packet from the IWF. (In case a route is already established, the packet may be routed from the MSC to the IWF without encapsulation by merely inserting the IWF's IP address as destination address.)

I.F Mobile Station (MS)

[0114] The PD functions of a packet data MS have to a large extent, directly or indirectly, been covered in the previous sections. Therefore, this section is primarily intended to serve as a complement and summary.

[0115] A packet data MS ("PD only", or combining PD with ordinary GSM functions) comprises:

- Mobile Termination (MT) which is based on current GSM MT technology, but adapted to provide the necessary PD functionality.
- Terminal Equipment (TE), e.g. "laptop/palmtop" personal computer, or "Personal Digital Assistant (PDA)"/"Personal Communicator".
- Subscriber Identity Module (SIM) of the same type as in ordinary GSM (but with additional parameters).

[0116] A range of MT versions providing different

standard interfaces towards TE will be available, depending on market requirements. Examples include:

- MT with asynchronous serial interface and PAD (Packet Assembly/Disassembly) support (e.g. AT command set PAD, X.28/X.29/X.3 PAD).
- "Integrated MT" with industry standard Application Program Interfaces (APIs).
- MT with synchronous serial interface (e.g. IP, X.25)

[0117] The MT comprises two main function blocks:

- Terminal adapter, typically microprocessor and software based, providing the TE interface as exemplified above.
- Transceiver, handling the radio interface. It is in the transceiver that most of the MS-related PD functions described in previous sections are performed, to a large extent realized with microprocessor software.

[0118] The major PD functions that the transceiver performs may be summarized as follows:

- From BCCH information, identifies the degree of PDCH support provided in a cell and the MPDCH allocated (if any) for initiating packet transfer.
- Handles PD mode in relation to ordinary GSM idle mode and (if applicable) call-connected mode.
- Handles the PDCH protocol.
- As required, requests allocation of an MPDCH on demand, using regular GSM control channels in the cell in question, or a PDCH of a currently serving adjacent cell, prior to moving into the cell in question.
- Handles mobile/stationary mode of operation and sends a mode indicator at least every time the MS changes its mode of operation.
- Handles normal/PD sleep paging mode and, explicitly or implicitly, sends a mode indicator at least every time the MS changes its paging mode.
- Performs cell selection in PD mode based on GSM idle mode procedures but with cell selection criteria, in stationary mode and (depending on chosen realization alternative) possibly also in mobile mode, modified such that the currently selected cell is retained as long as the signal quality is above a predefined threshold value.
- Performs location updating in PD mode based on regular GSM procedures.
- Handles the multi-TDMA frame scheme to coordinate listening to MPDCH on one hand, and performing cell selection and listening to cell broadcast short messages on the other.
- In the case of a combined MS, supporting also ordinary GSM services:

- Responds to paging on MPDCH related to reg-

ular GSM calls.

- Provides support for making and receiving regular GSM calls while the MS is in PD mode, maintaining PD mode as "pending" during calls.

II. Applicability to Other TDMA Cellular Systems

[0119] While specific embodiments of the present invention applied to a GSM type of cellular system have been described, it should be understood that the present invention may be applied also to other TDMA cellular systems including D-AMPS and PDC systems. Although in these systems, BSC is not provided as a separate functional entity, corresponding base station controller functions and associated new PD functions are instead divided between MSC and base stations.

TEXT TO THE DRAWINGS

20 Drawing 1/15 Figure

[0120]

— = PACKET DATA (PD) AND RELATED SIGNALLING
 . . . = CIRCUIT MODE VOICE/DEDICATED DATA AND RELATED SIGNALLING
 - - - = SIGNALLING

30 Drawing 2/15 Figure 2

[0121]

INTRANETWORK PROTOCOL AND INTERWORKING EXAMPLE (IP)
 E.G. IP ROUTER, LAN AND TCP/IP HOST AT CUSTOMER PREMISES

Drawing 3/15 Figure 3

[0122]

INTRANETWORK PROTOCOL AND INTERWORKING EXAMPLE (X. 2 5)

Drawing 5/15 Figure 5

[0123]

SEQUENCE DIAGRAM: MOBILE ORIGINATED PD STATE ESTABLISHMENT
 NOTE: ACK (23) INCLUDES INFORMATION ON MS' CELL LOCATION AND (OPTIONALLY) ON PDCH ALLOCATION (YES/NO) IN THE CELL

Drawing 6/15 Figure 6**[0124]**

DOWNLINK MULTIFRAMES

Drawing 7/15 Figure 7

MULTIFRAME CYCLE

[0125]

- (1) EXCEPT WHEN LISTENING TO CURRENT BCCH/EXTENDED BCCH
 (2) AFTER FLAG INDICATION ON PDCH BROADCAST

Drawing 8/15 Figure 8**[0126]**

SEQUENCE DIAGRAM: MOBILE ORIGINATED PDCH ON DEMAND ALLOCATION

Drawing 9/15 Figure 9**[0127]**

FLOW CHART: DYNAMIC ALLOCATION OF PDCHS

Drawing 10/15 Figure 10**[0128]**SEQUENCE DIAGRAM: MOBILE ORIGINATED PACKET TRANSFER EXAMPLE
NOTES (ASSUMPTIONS):

- MS IN PD STATE
- PDCH(S) ALLOCATED IN BTS
- NO RETRANSMISSIONS

Drawing 11/15 Figure 11**[0129]**SEQUENCE DIAGRAM: MOBILE TERMINATED PACKET TRANSFER EXAMPLE ("IMMEDIATE CHANNEL RESERVATION")
NOTES (ASSUMPTIONS):

- MS IN PD STATE
- PDCH(S) ALLOCATED IN BTS
- ROUTE FROM IWF TO CURRENT MSC ESTABLISHED
- MS IS CELL LOCATION KNOWN (E. G. MS MAY BE IN STATIONARY MODE)

- NO RETRANSMISSIONS

Drawing 12/15 Figure 12**[0130]**SEQUENCE DIAGRAM: MOBILE TERMINATED PACKET TRANSFER EXAMPLE (PAGING)
NOTES (ASSUMPTIONS):

- MS IN PD STATE
- PDCH(S) ALLOCATED IN BTS
- ROUTE FROM IWF TO CURRENT MSC ESTABLISHED
- PAGING OVER A SMALL NUMBER OF CELLS, USING A PAGING MESSAGE TYPE RESERVING AN ACCESS SLOT FOR THE MS TO RESPOND
- NO RETRANSMISSIONS

Drawing 13/15 Figure 13**[0131]**

MPDCH - PACKET TRANSFER EXAMPLES
 Rm = RANDOM ACCESS BURST
 Rd acc = RESERVED ACCESS BURST
 Index 1 = MS 1
 Index 2 = MS 2
 F = FREE
 R = RESERVED
 1= MOBILE ORIGINATED PACKET TRANSFER
 2= MOBILE TERMINATED PACKET TRANSFER

Drawing 14/15 Figure 14**[0132]**

ROUTING EXAMPLE - FIRST ADDRESSING SCHEME

Drawing 15/15 Figure 15**[0133]**

ROUTING EXAMPLE - SECOND ADDRESSING SCHEME

Claims

1. Apparatus for providing packet data communication to and from mobile stations (MS) in a digital TDMA cellular system comprising
 - a plurality of base stations (BTS, BSC) providing regular cellular control channels,
 - one or more mobile services switching centres

(MSC), each being associated with a visitor location register (VLR) and being coupled to a subordinated plurality of said base stations (BTS, BSC), and

- home location register means (HLR),
- first channel providing means for providing, in at least some of said base stations (BTS, BSC), on a per cell basis, one or more shared packet data channels for packet transfer to and from said mobile stations (MS), and first packet transfer controlling means for controlling said packet transfer,
- first channel defining means for defining, on a per cell basis, the packet data channel to be used for initiating packet transfer,
- first packet data mode establishing means for establishing packet data mode for any said mobile station (MS) to enable said mobile station (MS) to send and receive packets over said packet data channels,
- first packet transferring means for transferring packets between said mobile stations (MS) and any said base station (BTS, BSC),
- second packet transferring means for transferring packets between said base stations (BTS, BSC) and their respective superior mobile services switching centre (MSC),
- packet routing means for routing packets to and from the service area of any said mobile services switching centre (MSC),
- first means for performing location updating for any said mobile station (MS) in packet data mode,
- first packet data mode maintaining means for maintaining said packet data mode for any roaming mobile station (MS), and
- first packet data mode terminating means for terminating said established packet data mode for any said mobile station (MS),

characterized by

- first means for performing cell selection for any said mobile station in packet data mode, wherein the cell selection is controlled by said mobile station.
2. Apparatus according to claim 1, **characterized in that** said channel defining means comprises first information supplying means for supplying, on a regular cellular broadcast control channel, information defining the packet data channel to be used for initiating packet transfer, if such a packet data channel is provided in the cell in question.
 3. Apparatus according to claim 1 or 2, **characterized in that** said channel defining means comprises second information supplying means for supplying, on

a regular cellular broadcast control channel, information indicating that a packet data channel for initiating packet transfer may be provided by said channel providing means on user demand.

4. Apparatus according to any of claims 1-3, **characterized in that** said means for performing cell selection is adapted to perform cell selection based on regular cellular idle mode procedures.
5. Apparatus according to claim 4, **characterized in that** said means for performing cell selection comprises means for retaining the currently selected cell as long as the signal quality is above a predefined threshold value.
6. Apparatus according to any of claims 1-5, **characterized in that** said first means for performing location updating is adapted to perform location updating based on regular cellular idle mode procedures.
7. Apparatus according to any of claims 1- 6, **characterized in that** said first packet data mode establishing means comprises
 - means for initiating said establishment of packet data mode for a mobile station (MS), from an initial cellular idle mode, either by the mobile station (MS) generating a packet data service request, based on regular cellular control channel signalling, or by the mobile services switching centre (MSC), currently serving said mobile station (MS), receiving a packet addressed to the mobile station (MS), followed by paging based on regular cellular control channel signalling,
 - means for performing, as a following step, a regular cellular authentication procedure,
 - means for initiating parameters for packet encryption/decryption between the mobile station (MS) and its current mobile services switching centre (MSC), and
 - means for registering the mobile station at its current mobile services switching centre (MSC) with associated visitor location register (VLR) as being in packet data mode.

8. Apparatus according to any of claims 1-7, **characterized in that** said first channel providing means comprises
 - means for allocating, from a common pool of physical channels, a variable mix of packet data channels and regular cellular traffic channels determined by demand,
 - means for assigning the first packet data channel allocated in a cell as the channel for initiating packet transfer, capable of carrying access

- control signalling as well as packet data, and
- means for assigning any further allocated packet data channel(s) as channel(s) for reserved packet transfer.
9. Apparatus according to claim 8, **characterized in that** said first channel providing means is adapted to allocate said first packet data channel in a cell on user demand, and comprises
- means for allocating a packet data channel as a result of a successful packet data mode establishment, and
 - means for allocating a packet data channel, initiated by a mobile station in packet data mode generating a packet data channel allocation request, or initiated as a result of a successful paging to a mobile station in packet data mode, in either case based on regular cellular control channel signalling.
10. Apparatus according to claim 8 or 9, **characterized in that** said first channel providing means is adapted to allocate said first packet data channel in a cell on user demand, and comprises means for allocating a packet data channel, initiated by a mobile station in packet data mode generating a packet data channel allocation request for the cell in question prior to moving into said cell, using a packet data channel of a currently serving adjacent cell.
11. Apparatus according to any of claims 8 - 10, **characterized in that** said first channel providing means comprises
- means for measuring the traffic load on any allocated packet data channel, and
 - means for dynamically allocating a variable number of said channels for reserved packet transfer, based on traffic load measurements and availability of said physical channels.
12. Apparatus according to claim 11, **characterized in that** said first channel providing means further comprises
- means for dynamically allocating a variable number of said packet data channels for initiating packet transfer, such that a group of these channels can be used together with a common group of packet data channels for reserved packet transfer, and
 - means for directing any mobile station (MS) to a particular one of said packet data channels for initiating packet transfer, if more than one such channel is allocated, based on mobile station identity and broadcasted control information.
13. Apparatus according to any of claims 1-12, **characterized in that** said packet transferring means, for initiating a packet transfer to a mobile station (MS) in packet data mode, comprise paging means and monitoring means for monitoring the cell location of the mobile station (MS) based on any previous packet transfer, and further **characterized in that** said packet transferring means are adapted to enable the use of paging guided by said monitoring means to initiate a packet transfer to a mobile station (MS).
14. Apparatus according to claim 13, **characterized in that** said monitoring means comprises
- means for identifying the cell location of a mobile station (MS) originating a packet by, when the packet is received at the mobile services switching centre (MSC) currently serving the mobile station, associating the packet with the identity of the, for each cell unique, connection on which the packet is received,
 - means for identifying the cell location of a mobile station responding to a paging message, and
 - means for storing for a mobile station (MS), linked to its packet mode registration, at least the latest cell location identified and an associated time when the cell location was identified.
15. Apparatus according to claim 13 or 14, **characterized in that** said packet transferring means, for initiating a packet transfer to a mobile station (MS), further comprise means for monitoring a mobile/stationary mode indicator sent by a mobile station (MS), capable of operating in stationary mode, to its currently serving mobile services switching centre (MSC) at least every time it changes from mobile to stationary mode or vice versa.
16. Apparatus according to claim 15, **characterized in that** said packet transferring means are adapted to, to a mobile station (MS) that is in stationary mode and performs cell selection according to claim 5, initiate a packet transfer without previous paging or with paging in a single cell.
17. Apparatus according to any of claims 13-16, **characterized in that** said packet transferring means are adapted to, also to a mobile station (MS) that is in mobile mode and performs cell selection according to claim 5, initiate a packet transfer without previous paging or with paging in a single cell, provided that the cell location information from said monitoring means meets predefined accuracy criteria.
18. Apparatus according to any of claims 1-17, **characterized in that** said packet transferring means, for

initiating packet transfers to mobile stations (MS) in packet data mode, comprise paging means adapted to include a paging message type, combining paging request(s) with reservation(s) of individual access slots for the mobile station(s) (MS) to respond.

19. Apparatus according to any of claims 1-18, **characterized in that** said packet transferring means comprise paging means adapted to convey, on a packet data channel, paging related to a regular cellular call to a mobile station (MS) in packet data mode.

20. Apparatus according to any of claims 4-19, **characterized in that** said first packet transferring means and said means for performing cell selection, to coordinate initiating packet transfers to mobile stations (MS) with performing cell selection in said mobile stations (MS), comprise means for scheduling paging and other messages, initiating packet transfers to mobile stations (MS), according to a multi-TDMA frame scheme, synchronized with the corresponding multiframe schemes used for regular cellular control channel signalling, allowing predefined times for mobile stations (MS) to perform cell selection and to receive regular cellular broadcast messages.

21. Apparatus according to any of claims 1-20, **characterized in that** said first packet data mode maintaining means comprises means for allowing a mobile station (MS) in packet data mode to make and receive regular cellular calls, means for maintaining packet data mode as pending during a call, and means for returning the mobile station to active packet data mode when the call is completed.

22. Apparatus according to any of claims 1-21, **characterized in that** said packet routing means comprises

- one or more interworking function means (IWF) for interworking with external network(s),
- interconnection means for interconnecting said interworking function means (IWF) and mobile services switching centres (MSC), and
- means for routing packets, addressed to a mobile station (MS), from any said interworking function means (IWF) to the mobile services switching centre (MSC) currently serving said mobile station, including, for establishing a route to said mobile services switching centre (MSC),
 - means for initially interrogating home location register (HLR) to determine the identity of said mobile services switching centre (MSC),

- at said interworking function means (IWF), means for storing, linked to the identity of said mobile station, the identity of said mobile services switching centre (MSC), and
- at said mobile services switching centre (MSC), means for initiating, as required, establishment of packet data mode for said mobile station, and means for determining and storing, linked to the packet data mode registration of said mobile station, the identity of said interworking function means (IWF).

23. Apparatus according to any of claims 1- 22, **characterized in that** said packet routing means comprises

- interconnection means for interconnecting mobile services switching centres (MSC), and
- means for routing packets originated from a first mobile station (MS1) and addressed to a second mobile station (MS2) including:
 - at the mobile services switching center currently serving the first mobile station, means for determining from stored routing information whether a route to the mobile services switching center currently serving the second mobile station is established, linked to a packet data mode registration of the first mobile station; means for routing packets to the second mobile station's currently serving mobile services switching center when a route is established; and means for initially interrogating the home location register means to determine an identity of the mobile services switching center currently serving the second mobile station when a route is not established, and for storing, as routing information, the identity of the second mobile station's currently serving switching center with the identity of the second mobile station, linked to the packet data mode registration of the first mobile station; and
 - at the mobile services switching centre currently serving said second mobile station (MS2), means for initiating establishment of packet data mode for said second mobile station (MS2) when packet data mode is not already established, and means for determining and storing, linked to the packet data mode registration of said second mobile station (MS2), the identity of said first mobile station (MS1) and its current mobile services switching centre.

24. Apparatus according to any of claims 1-21, **characterized in that**

terized in that said packet routing means comprises

- interconnection means for interconnecting mobile services switching centres (MSC), and for connecting mobile services switching centres to external network(s), directly or via separate interworking function means (IWF),
- means for routing packets addressed to a mobile station (MS), from external network(s) or other mobile station(s), to a predetermined mobile services switching centre (MSC) to which the mobile station belongs from an addressing point of view, and
- means for routing packets, addressed to a mobile station, from said predetermined mobile services switching centre to the (same or different) mobile services switching, centre currently serving said mobile station, including
- at the addressed mobile services switching center, means for determining from stored routing information whether a route to the mobile station's currently serving mobile services switching center is established, linked to an identity of the mobile station; means for routing packets to the currently serving mobile services switching center when a route is established; and means for initially interrogating the home location register means, when a route is not established, to determine an identity of the currently serving mobile services switching center, and for storing, as routing information, the identity of the currently serving mobile services switching center linked to the identity of the mobile station; and
- at said currently serving mobile services switching centre, means for initiating, as required, establishment of packet data mode for said mobile station when packet data mode is not already established, and means for determining and storing, linked to the packet data mode registration of said mobile station, the identity of said predetermined mobile services switching centre.

25. Apparatus according to any of claims 1-24, **characterized in that** said first packet data mode maintaining means, for maintaining packet data mode for a mobile station when it moves to a location area belonging to a new mobile services switching centre (MSC), comprises means for transferring the packet data mode registration and associated information, stored at the mobile station's currently serving mobile services switching centre (MSC) (with associated visitor location register (VLR)), from the old to the new mobile services switching centre.

26. Apparatus according to any of claims 22-25, **characterized in that** said packet routing means, for maintaining routes established to a mobile station's currently serving mobile services switching centre (MSC) when the mobile station moves to a location area belonging to a new mobile services switching centre, comprises means for updating peer entities - interworking function means (IWF) and/or mobile services switching centres (MSC) - of any routes established on the change of mobile services switching centre, currently serving the mobile station.

27. Apparatus according to any of claims 22-26, **characterized in that** said packet routing means comprises

- at a mobile station's currently serving mobile services switching centre (MSC), means for monitoring as to traffic activity any route established to said mobile services switching centre, linked to the identity of said mobile station, and means for initiating termination of said route when the traffic activity falls below a predetermined level, and
- at the peer entity - interworking function means or mobile services switching centre - of any said route, means for cancelling related routing information, stored at said entity, when termination of said route is initiated.

28. Apparatus according to any of claims 1-27, **characterized in that** said first packet data mode terminating means comprises means for monitoring a mobile station as to traffic activity, and means for terminating packet data mode and any associated routes established when the traffic activity falls below a predetermined level.

29. Apparatus according to any of claims 1-28, **characterized in that** said first packet data mode terminating means comprises means for monitoring the time elapsed since packet data mode was established for a mobile station, and means for terminating packet data mode and any associated routes established when the time elapsed exceeds a predetermined period of time.

30. Mobile station for packet data communication over digital TDMA cellular shared packet data channels enabled by apparatus according to any of claims 1-29, said mobile station comprising:

- first channel identifying means for identifying, on a per cell basis, the packet data channel to be used for initiating packet transfer,
- second packet data mode establishing means for establishing packet data mode for the mobile station (MS) to enable it to send and receive

- packets over said packet data channels,
- first means for sending and receiving packets over said packet data channels,
- second means for performing location updating in packet data mode, 5
- second packet data mode maintaining means for maintaining said packet data mode for the mobile station (MS), and
- second packet data mode terminating means for terminating said established packet data mode for said mobile station (MS), 10

characterized by

- second means for performing cell selection in packet data mode, wherein cell selection is controlled by the mobile station. 15

31. Mobile station according to claim 30, **characterized in that** said first channel identifying means is adapted to read from a regular cellular broadcast control channel, information supplied for defining the packet data channel to be used for initiating packet transfer, if such a packet data channel is provided in the cell in question. 20 25

32. Mobile station according to claim 30 or 31, **characterized in that** said first channel identifying means is adapted to read from a regular cellular broadcast control channel, information supplied for indicating that a packet data channel for initiating packet transfer may be provided on user demand. 30

33. Mobile station according to any of claims 30-32, **characterized in that** said second means for performing cell selection is adapted to perform cell selection based on regular cellular idle mode procedures. 35

34. Mobile station according to claim 33, **characterized in that** said second means for performing cell selection comprises means for retaining the currently selected cell as long as the signal quality is above a predefined threshold value. 40 45

35. Mobile station according to any of claims 30-34, **characterized in that** said second means for performing location updating is adapted to perform location updating based on regular cellular idle mode procedures. 50

36. Mobile station according to any of claims 30-35, **characterized in that** said second packet data mode establishing means comprises 55

- means for initiating said establishment of packet data mode in the mobile station (MS), from an initial cellular idle mode, either by the mobile

station (MS) generating a packet data service request, based on regular cellular control channel signalling, or by the mobile station receiving a paging message, based on regular cellular control channel signalling, indicating that a packet, addressed to the mobile station (MS), is received by the mobile services switching centre (MSC), currently serving the mobile station (MS),

- means for performing, as a following step, a regular cellular authentication procedure,
- means for initiating parameters for packet encryption/decryption in the mobile station (MS), and
- means for storing, in the mobile station, information indicating that packet data mode is established.

37. Mobile station according to any of claims 30-36, further **characterized by** means for, when the mobile station is in packet data mode and is located in a cell providing a packet data channel on user demand, generating a packet data channel allocation request, based on regular cellular control channel signalling.

38. Mobile station according to any of claims 30-37, further **characterized by** means for, when the mobile station is in packet data mode and is located in a cell with packet data channel(s) allocated, generating a packet data channel allocation request for an adjacent cell, providing packet data channel on user demand, prior to moving into said adjacent cell, using a packet data channel of the currently serving cell.

39. Mobile station according to any of claims 30-38, **characterized in that** said first means for sending and receiving packets comprises means for sending a mobile/stationary mode indicator to the mobile services switching centre (MSC) currently serving the mobile station, at least every time the mobile station changes from mobile to stationary mode or vice versa.

40. Mobile station according to any of claims 30-39, **characterized in that** said first means for sending and receiving packets comprises means for responding to a paging message type, combining paging request with reservation of an individual access slot for the mobile station (MS) to respond.

41. Mobile station according to any of claims 30-40, **characterized in that** said first means for sending and receiving packets comprises means for responding to paging, on a packet data channel, related to a regular cellular call.

42. Mobile station according to any of claims 33-41, **characterized in that** said first means for sending and receiving packets and said second means for performing cell selection, to coordinate listening to the packet data channel on which packet transfers to the mobile station (MS) are initiated with performing cell selection, comprise means for scheduling listening for paging and other messages, initiating packet transfers to the mobile station (MS), according to a multi-TDMA frame scheme, synchronized with the corresponding multiframe schemes used for regular cellular control channel signalling, allowing predefined times for the mobile station (MS) to perform cell selection and to receive regular cellular broadcast messages.

5

10

15

43. Mobile station according to any of claims 30-42, **characterized in that** said second packet data mode maintaining means comprises means for allowing the mobile station to make and receive regular cellular calls when being in packet data mode, means for maintaining packet data mode as pending during a call, and means for returning the mobile station to active packet data mode when the call is completed.

20

25

Patentansprüche

1. Einrichtung zum Bereitstellen von Paketdatenkommunikation zu und von Mobilstationen (MS) in einem Digital-TDMA-Zellularsystem, umfassend:

30

- Eine Vielzahl von reguläre Zellularsteuerkanäle bereitstellenden Basisstationen (BTS,BSC),

35

- Eine oder mehrere Mobildienstvermittlungszentren (MSC), von denen jeder ein Besucherregister (VLR) zugeordnet ist und die gekoppelt sind mit einer untergeordneten Vielzahl der Basisstationen (BTS,BSC) und

40

- Eine Heimatregistervorrichtung (HLR)

- Eine erste Kanalbereitstellungsvorrichtung zum Bereitstellen in mindestens einigen der Basisstationen (BTS,BSC) auf einer Pro-Zellen-Basis einen oder mehrere geteilte Paketdatenkanäle für Paketübertragung zu und von den Mobilstationen (MS) und eine erste Paketübertragungssteuervorrichtung zum Steuern der Paketübertragung,

45

50

- Eine erste Kanaldefinitionsvorrichtung zum Definieren auf einer Pro-Zellen-Basis des zur Veranlassung von Paketübertragung zu verwendenden Paketdatenkanals,

55

- Eine erste Paketdatenmodus-Einrichtungsvorrichtung zum Einrichten des Paketdatenmodus, um irgendwelche der Mobilstationen (MS) zu befähigen, dieser Mobilstation (MS), Pakete über Paketdatenkanäle zu senden und zu empfangen,

- Eine erste Paketübertragungsvorrichtung zum Übertragen von Paketen zwischen den Mobilstationen (MS) und irgendwelchen der Basisstationen (BTS,BSC),

- Eine zweite Paketübertragungsvorrichtung zum Übertragen von Paketen zwischen den Basisstationen (BTS,BSC) und ihren jeweils übergeordneten Mobildienstvermittlungszentren (MSC),

- Eine Paket-Routing-Vorrichtung zum Routen von Paketen zu und von dem Dienstebereich irgendeines der Mobildienstvermittlungszentren (MSC),

- Eine erste Vorrichtung zum Ausführen von Ortsaktualisierung für irgendwelche der Mobilstationen (MS) im Paketsdatenmodus.

- Eine erste Paketsdatenmodus-Aufrechterhaltungsvorrichtung zum Aufrechterhalten des Paketsdatenmodus für irgendeine roaming-durchführende Mobilstation (MS), und

- Eine erste Paketdatenmodus-Beendigungsvorrichtung zum Beenden des eingerichteten Paketsdatenmodus für irgendeine Mobilstation (MS),

gekennzeichnet durch

- Eine erste Vorrichtung zum Durchführen von Zellen Selektion für irgendeine Mobilstation im Paketsdatenmodus, wobei die Zellen Selektion gesteuert wird **durch** die Mobilstation.

2. Einrichtung nach Anspruch 1, **dadurch gekennzeichnet, dass** die Kanaldefinitionsvorrichtung eine erste Informationszufuhrvorrichtung zum Zuführen von Information auf einem regulären Zellularsendsendesteuersignal, welche den für das Veranlassen von Paketübertragung zu verwendenden Paketdatenkanal definiert, wenn ein solcher Paketdatenkanal in der fraglichen Zelle bereitgestellt wird.

3. Vorrichtung nach Anspruch 1 oder 2, **dadurch gekennzeichnet, dass** die Kanaldefinitionsvorrichtung eine zweite Informationszufuhrvorrichtung umfasst zum Zuführen von Information auf einem

- regulären Zellularrundsendesteuersignal, welche anzeigt, dass ein Paketdatenkanal zum Veranlassen von Paketübertragung bereitgestellt werden kann von der Kanalbereitstellungsvorrichtung auf Anforderung des Benutzers.
4. Vorrichtung nach einen der Ansprüche 1-3, **dadurch gekennzeichnet, dass** die Vorrichtung zum Durchführen von Zellen Selektion ausgestaltet ist zum Durchführen von Zellen Selektion basierend auf regulären Zellularruhezustandsmodusprozeduren.
5. Einrichtung nach Anspruch 4, **dadurch gekennzeichnet, dass** die Vorrichtung zum Durchführen von Zellen Selektion eine Vorrichtung umfasst zum Beibehalten der momentan ausgewählten Zelle so lange, wie die Signalqualität oberhalb eines vorbestimmten Schwellwertes ist.
6. Einrichtung nach einem der Ansprüche 1-5, **dadurch gekennzeichnet, dass** die erste Vorrichtung zum Durchführen von Ortsaktualisierung ausgestaltet ist zum Durchführen von Ortsaktualisierung basierend auf regulären Zellularruhezustandsmodusprozeduren.
7. Einrichtung nach einen der Ansprüche 1-6, **dadurch gekennzeichnet, dass** die erste Paketdatenmodus-Einrichtungsvorrichtung umfasst:
- Eine Vorrichtung zum Veranlassen des Einrichtens eines Paketdatenmodus für eine Mobilstation (MS) aus einem Ausgangszellularruhezustandsmodus, entweder von der das Generieren eines Paketdatendienstes anfordernden Mobilstation (MS) basierend auf regulärer Zellensteuerkanalsignalisierung oder von dem momentan die Mobilstation (MS) bedienenden Mobildienstvermittlungszentrum (MSC), das ein an die Mobilstation (MS) adressierte Paket empfängt, gefolgt durch Funkruf bzw. Paging basierend auf regulärer Zellensteuerkanalsignalisierung,
 - Eine Vorrichtung zum Durchführen einer regulären Zellenauthentizitätsprozedur als nachfolgender Schritt,
 - Eine Vorrichtung zum Veranlassen von Parametern zur Paketverschlüsselung/Entschlüsselung zwischen der Mobilstation (MS) und ihrem momentanen Mobildienstvermittlungszentrum (MSC) und
 - eine Vorrichtung zum Registrieren der Mobilstation (MS) bei ihren momentanen Mobildienstvermittlungszentrum (MSC) im zugeordneten
- tem Besucherregister (VLR) als im Paketdatenmodus seiend.
8. Einrichtung nach einem der Ansprüche 1-7, **dadurch gekennzeichnet, dass** die erste Kanalbereitstellungsvorrichtung umfasst:
- Eine Vorrichtung zum Zuordnen einer bedarfsbestimmten veränderlichen Mischung von Paketdatenkanälen und regulären Zellenverkehrskanälen aus einem gemeinsamen Vorrat von physikalischen Kanälen,
 - Eine Vorrichtung zum Festlegen des ersten in einer Zelle zugeordneten Paketdatenkanals als den Kanal zum Veranlassen von Paketübertragung, befähigt zum Tragen von Zugangssteuersignalisierung sowie Paketdaten, und
 - Eine Vorrichtung zum Festlegen jedes weiteren zugeordneten Paketdatenkanals als Kanal für reservierte Paketübertragung.
9. Einrichtung nach Anspruch 8, **dadurch gekennzeichnet, dass** die erste Kanäle bereitstellende Vorrichtung ausgestaltet, zum Zuordnen des ersten Paketdatenkanals in einer Zelle auf Bedarf eines Benutzers, und umfasst :
- Eine Vorrichtung zum Zuordnen eines Paketdatenkanals als ein Ergebnis eines erfolgreichen Paketdatenmoduseinrichtens, und
 - eine Vorrichtung zum Zuordnen eines Paketdatenkanals veranlasst durch eine im Paketdatenmodus eine Paketsdatenkanal-Zuordnungsanfrage generierende Mobilstation (MS) oder veranlasst als Ergebnis eines erfolgreichen Funkrufs bzw. Paging an eine Mobilstation (MS) im Paketdatenmodus, in jedem Fall basierend auf regulärer Zellensteuerkanalsignalisierung.
10. Einrichtung nach Anspruch 8 oder 9, **dadurch gekennzeichnet, dass** die erste Kanalbereitstellungsvorrichtung ausgestaltet ist zum Zuordnen des ersten Paketdatenkanals in einer Zelle und eine Vorrichtung umfasst zum Zuordnen eines Paketdatenkanals veranlasst durch eine im Paketdatenmodus eine Paketdatenkanal-Zuordnungsanfrage für die fragliche Zelle generierende Mobilstation (MS) vor dem Bewegen in diese Zelle unter Verwendung eines Paketdatenkanals einer momentan bedienenden Nachbarzelle.
11. Einrichtung nach einem der Ansprüche 8-10, **dadurch gekennzeichnet, dass** die erste Kanalbereitstellungsvorrichtung umfasst:

- Eine Vorrichtung zum Messen der Verkehrsbelastung auf jedem zugeordneten Paketdatenkanal, und
 - eine Vorrichtung zur dynamischen Zuordnung einer variablen Anzahl dieser Kanäle für reservierte Paketübertragung basieren auf Verkehrslastmessungen und der Verfügbarkeit der physikalischen Kanäle.
12. Einrichtung nach Anspruch 11, **dadurch gekennzeichnet, dass** die erste Kanalbereitstellungsvorrichtung außerdem umfasst:
- Eine Vorrichtung zum dynamischen Zuordnen einer variablen Anzahl der Paketdatenkanäle zum Veranlassen von Paketübertragung derart, dass eine Gruppe dieser Kanäle gemeinsam benutzt werden kann mit einer gemeinsamen Gruppe von Paketsdatenkanälen für reservierte Paketübertragung, und
 - eine Vorrichtung zum Richten jeder Mobilstation auf einen speziellen der Paketdatenkanäle zum Veranlassen von Pakettransfer, wenn mehr als einer solcher Kanäle zugeordnet ist basierend auf der Mobilstationsidentität und rumgesendeter Steuerinformation.
13. Einrichtung nach einem der Ansprüche 1-12, **dadurch gekennzeichnet, dass** die Paketübertragungsvorrichtung zum Veranlassen einer Paketübertragung zu einer Mobilstation (MS) im Paketdatenmodus eine Funkruf- bzw. Pagingvorrichtung umfasst und eine Überwachungsvorrichtung zum Überwachen des Zellenortes der Mobilstation (MS) basierend auf irgend welcher vorangegangener Paketübertragung und außerdem **dadurch gekennzeichnet, dass** die Paketübertragungsvorrichtung ausgestaltet ist zum Zulassen der Verwendung von der Überwachungsvorrichtung geführtem Paging zum Veranlassen einer Paketübertragung zu einer Mobilstation (MS).
14. Einrichtung nach Anspruch 13, **dadurch gekennzeichnet, dass** die Überwachungsvorrichtung umfasst:
- Eine Vorrichtung zum Identifizieren des Zellenortes einer Mobilstation (MS), von der ein Paket stammt, durch Zuordnen einer Identität von der für jede Zelle einzigartigen Verbindung, über die das Paket empfangen worden ist zu dem Paket, wenn das Paket in dem momentan die Mobilstation (MS) bedienenden Mobildienstvermittlungszentrum (MSC) empfangen worden ist.
 - Eine Vorrichtung zum Identifizieren des Zellen-
- ortes der Mobilstation (MS) ansprechend auf eine Paging-Meldung und
- eine Vorrichtung zum Speichern zumindest des letzten identifizierten Zellenortes und einer zugeordneten Zeit für eine mit ihrer Paketmodusregistrierung verbundene Mobilstation (MS), wenn der Zellenort identifiziert worden ist.
15. Einrichtung nach Anspruch 13 oder 14, **dadurch gekennzeichnet, dass** die Paketübertragungsvorrichtung zum Veranlassen einer Paketübertragung zu einer Mobilstation (MS) außerdem eine Vorrichtung umfasst zum Überwachen eines Mobil-/Stationärmodusindikators, der von einer Mobilstation (MS) gesendet worden ist mit der Fähigkeit, im Stationärmodus betrieben zu werden, zu deren momentan bedienendem Mobildienstvermittlungszentrum (MSC) zumindest jedes Mal, wenn er vom mobilen zum Stationärmodus wechselt oder umkehrt.
16. Einrichtung nach Anspruch 15, **dadurch gekennzeichnet, dass** die Paketübertragungsvorrichtung ausgestaltet ist, um für eine Mobilstation (MS), die sich im Stationärmodus befindet und Zellen Selektion gemäß Anspruch 5 ausführt, eine Paketübertragung zu veranlassen ohne vorheriges Paging oder mit Paging in einer einzelnen Zelle.
17. Einrichtung nach einem der Ansprüche 13-16, **dadurch gekennzeichnet, dass** die Paketübertragungsvorrichtungen ausgestaltet sind, um auch für eine Mobilstation (MS), die sich im Mobilmodus befindet und Zellen Selektion gemäß Anspruch 5 durchführt, eine Paketübertragung zu veranlassen ohne vorhergehendes Paging oder mit Paging in einer einzelnen Zelle, vorausgesetzt, dass die Zellenortsinformation von der Überwachungsvorrichtung vorbestimmte Genauigkeitskriterien erfüllt.
18. Einrichtung nach einem der Ansprüche 1-17, **dadurch gekennzeichnet, dass** die Paketübertragungsvorrichtung zum Veranlassen von Paketübertragungen zu Mobilstationen (MS) im Paketdatenmodus eine Pagingvorrichtung umfasst, ausgestaltet zum Einschließen eines Pagingmeldungstyps, Paginganfrage(n) mit Pagingreservierung(en) individueller Zugangsschlitzte kombinierend für die Mobilstation(en) (MS) zum Antworten.
19. Einrichtung nach einem der Ansprüche 1-18, **dadurch gekennzeichnet, dass** die Paketübertragungsvorrichtung eine Pagingvorrichtung umfasst, ausgestaltet zum Befördern auf einem Datenpaketkanal von einem regulären Zellularruf betreffenden Paging zu einer Mobilstation (MS) im Paketdatenmodus.

20. Einrichtung nach einem der Ansprüche 4-19, **dadurch gekennzeichnet, dass** die erste Paketübertragungsvorrichtung und die Vorrichtung zum Durchführen von Zellen Selektion zum Koordinieren des Veranlassens von Paketübertragungen zu Mobilstationen (MS) mit dem Durchführen von Zellen Selektionen in den Mobilstationen (MS) eine Vorrichtung umfasst zur Planung von Paging- und anderen Meldungen, zum Veranlassen von Paketübertragung zu Mobilstationen (MS) entsprechend einem Mehrfach-TDMA-Rahmenschema, synchronisiert mit den entsprechenden Mehrfachrahmenschemata, die zur regulären Zellularsteuerkanalsignalisierung verwendet werden und vorbestimmte Zeiten für Mobilstationen (MS) zulassen zum Durchführen von Zellen Selektion und zum Empfangen regulärer Zellular-Rundsendemeldungen.
21. Einrichtung nach einem der Ansprüche 1-20, **dadurch gekennzeichnet, dass** die erste Paketdatenmodus-Aufrechterhaltungsvorrichtung eine Vorrichtung umfasst zum Zulassen einer Mobilstation (MS) im Paketdatenmodus, um reguläre Zellularrufe zu machen und zu empfangen, eine Vorrichtung zum Aufrechterhalten von Paketdatenmodus als Anhänger während eines Rufs anhängig und eine Vorrichtung zum Zurückführen der Mobilstation (MS) zum Aktivpaketdatenmodus, wenn der Ruf abgeschlossen ist.
22. Einrichtung nach einem der Ansprüche 1-21, **dadurch gekennzeichnet, dass** die Paket-Routing-Vorrichtung umfasst:
- Eine oder mehrere Netzanpassungsfunktions- bzw. Interworkingfunktionsvorrichtungen (IWF) zum Zwischenvernetzen mit externen Netzen,
 - Eine Zwischenverbindungsvorrichtung zum Zwischenverbinden der Netzanpassungsfunktionsvorrichtung (IWF) und der Mobildienstvermittlungszentren (MSC), und
 - Eine Vorrichtung zum Routing von Paketen, die an eine Mobilstation (MS) adressiert sind von irgendeiner der Netzanpassungsfunktionsvorrichtungen (IWF) zu dem Mobildienstvermittlungszentrum (MSC), das momentan die Mobilstation (MS) bedient, einschließlich, zum Einrichten eines Leitweges zu dem Mobildienstvermittlungszentrum (MSC),
 - Eine Vorrichtung zum anfänglichen Abfragen des Heimatregisters (HLR) zum Bestimmen der Identität des Mobildienstvermittlungszentrums (MSC),
 - Bei der Netzanpassungsfunktionsvorrichtung
- (IWF) eine Vorrichtung zum Speichern der Identität des Mobildienstvermittlungszentrums (MSC) verbunden mit der Identität der Mobilstation (MS) und
- Bei dem Mobildienstvermittlungszentrum (MSC), eine Vorrichtung zum Veranlassen des Einrichtens eines Paketdatenmodus für die Mobilstation (MS) wenn nötig, und eine Vorrichtung zum Bestimmen und Speichern, verbunden mit der Datenpaketmodusregistrierung der Mobilstation, der Identität der Netzanpassungsfunktionsvorrichtung (IWF).
23. Einrichtung nach einem der Ansprüche 1-22, **dadurch gekennzeichnet, dass** die Paket-Routing-Vorrichtung umfasst:
- Eine Zwischenverbindungsvorrichtung zum Zwischenverbinden der Mobildienstvermittlungszentren (MSC) und
 - eine Vorrichtung zum Routing von von einer ersten Mobilstation (MS1) stammenden und an eine zweite Mobilstation (MS2) adressierten Paketen einschließlich:
 - Bei dem die erste Mobilstation (MS1) momentan bedienenden Mobildienstvermittlungszentrum, einer Vorrichtung zum Bestimmen von gespeicherter Routing-Information, ob ein Leitweg zu dem Mobildienstvermittlungszentrum, das momentan die Zweitmobilstation bedient, eingerichtet ist, verbunden mit einer Paketsdatenmodusregistrierung der ersten Mobilstation (MS1); eine Vorrichtung zum Routing von Paketen zu dem die Zweitmobilstation momentan bedienenden Mobildienstvermittlungszentrum, wenn ein Leitweg eingerichtet ist; und eine Vorrichtung zum anfänglichen Abfragen der Heimatregistervorrichtung zum Bestimmen einer Identität des momentan die zweite Mobilstation bedienenden Mobildienstvermittlungszentrums, wenn kein Leitweg eingerichtet ist, und zum Speichern der Identität des die zweite Mobilstation momentan bedienenden Vermittlungszentrums als Routing-Information mit der Identität der zweiten Mobilstation, verbunden mit der Datenpaketmodusregistrierung der ersten Mobilstation; und
 - bei dem die zweite Mobilstation (MS2) momentan bedienenden Mobildienstvermittlungszentrum über eine Vorrichtung zum Veranlassen des Einrichtens eines Paket-

datenmodus für die zweite Mobilstation (MS2), wenn der Paketdatenmodus nicht bereits eingerichtet ist und eine Vorrichtung zum Bestimmen und Speichern, verbunden mit der Paketdatenmodusregistrierung der zweiten Mobilstation (MS2), der Identität der ersten Mobilstation (MS1) und ihres momentanen Mobildienstevermittlungszentrums.

24. Einrichtung nach einem der Ansprüche 1-21, **dadurch gekennzeichnet, dass** die Paket-Routing-Vorrichtung umfasst:

- Eine Zwischenverbindungsvorrichtung zum Zwischenverbinden von Mobildienstevermittlungszentren (MSC) und zum Verbinden von Mobildienstevermittlungszentren mit externen Netzen unmittelbar oder über separate Netzanpassungs-Funktionsvorrichtungen (IWF),
- Eine Vorrichtung zum Routing von Paketen, die an eine Mobilstation (MS) adressiert sind von einem oder mehreren externen Netzen oder einer oder mehreren anderen Mobilstationen zu einem vorbestimmten Mobildienstevermittlungszentrum (MSC), zu dem die Mobilstation der Adressierung nach gehört, und
- eine Vorrichtung zum Routing von Paketen, die an eine Mobilstation (MS) adressiert sind, von dem vorbestimmten Mobildienstevermittlungszentrum zu dem (selben oder unterschiedlichen) Mobildienstevermittlungszentrum, das momentan die Mobilstation (MS) bedient, einschließlich
- bei dem adressierten

Mobildienstevermittlungszentrum, einer Vorrichtung zum Bestimmen aus der gespeicherten Routing-Information, ob ein Leitweg zu dem die Mobilstation momentan bedienenden

Mobildienstevermittlungszentrum eingerichtet ist, verbunden mit einer Identität der Mobilstation;

einer Vorrichtung zum Routing von Paketen zu dem momentan bedienenden

Mobildienstevermittlungszentrum, wenn ein Leitweg eingerichtet ist; und einer Vorrichtung zum anfänglichen Abfragen der Heimatregistervorrichtung, wenn ein Leitweg nicht eingerichtet ist, zum Bestimmen einer Identität des momentan bedienenden

Mobildienstevermittlungszentrums und zum Speichern der Identität des momen-

tan bedienenden Mobildienstevermittlungszentrums verbunden mit der Identität der Mobilstation als Routing-Information; und

- bei dem momentan bedienenden

Mobildienstevermittlungszentrum, eine Vorrichtung, um nötigenfalls das Einrichten des Paketdatenmodus für die Mobilstation zu veranlassen, wenn der Paketdatenmodus nicht bereits eingerichtet ist und eine Vorrichtung zum Bestimmen und Speichern, verbunden mit der Paketsdatenmodusregistrierung dieser Mobilstation, der Identität des vorbestimmten Mobildienstevermittlungszentrums.

25. Einrichtung nach einem der Ansprüche 1-24, **dadurch gekennzeichnet, dass** die erste Paketdatenmodus-Aufrechterhaltungsvorrichtung zum Aufrechterhalten von Paketdatenmodus für eine Mobilstation, wenn sie sich zu einem Ortsbereich bewegt, der zu einem neuen Mobildienstevermittlungszentrum (MSC) gehört, eine Vorrichtung umfasst zum Übertragen der Paketdatenmodusregistrierung und zugeordneter Information, die bei dem die Mobilstation momentan bedienenden Mobildienstevermittlungszentrum (MSC) gespeichert ist, (mit zugeordnetem Besucherregister (VLR)), von dem alten zu dem neuen Mobildienstevermittlungszentrum.

26. Einrichtung nach einem der Ansprüche 22-25, **dadurch gekennzeichnet, dass** die Paket-Routing-Vorrichtung zum Aufrechterhalten von eingerichteten Leitwegen zu einem eine Mobilstation momentan bei dienenden Mobildienstevermittlungszentrum (MSC), wenn die Mobilstation sich zu einen Ortsbereich bewegt, der zu einem neuen Mobildienstevermittlungszentrum gehört, eine Vorrichtung umfasst zum Aktualisieren von Partnerinstanzen bzw. Peer-Einheiten - Netzanpassungsfunktionsvorrichtung (IWF) und/oder Mobildienstevermittlungszentren (MSC) - irgendwelcher Leitwege, die eingerichtet sind auf das Ändern des Mobildienstevermittlungszentrums, das momentan die Mobilstation bedient.

27. Einrichtung nach einem der Ansprüche 22-26, **dadurch gekennzeichnet, dass** die Paket-Routing-Vorrichtung umfasst:

- Bei einem eine Mobilstation momentan bedienenden Mobildienstevermittlungszentrum (MSC) eine Vorrichtung zum Überwachen bezüglich Verkehrsaktivität irgendwelcher Leitwege, die zu dem Mobildienstevermittlungszentrum

- trum eingerichtet sind, verbunden mit der Identität der Mobilstation, und eine Vorrichtung zum Veranlassen des Beendens dieser Leitwege, wenn die Verkehrsaktivität unterhalb einen vorbestimmten Pegel fällt.
- 5
- Bei der Peer-Einheit - Netzanpassungsfunktionsvorrichtung oder Mobildienstevermittlungszentrum - irgendeiner dieser Leitwege, eine Vorrichtung zum Löschen zugehöriger Routing-Information, die bei dieser Einheit gespeichert ist, wenn das Beenden dieses Leitweges veranlasst ist.
- 10
28. Einrichtung nach einem der Ansprüche 1-27, **dadurch gekennzeichnet, dass** die erste Paketdatenmodus-Beendungsvorrichtung eine Vorrichtung umfasst zum Überwachen einer Mobilstation bezüglich Verkehrsaktivität und eine Vorrichtung zum Beenden des Paketsdatenmodus und irgendwelcher zugeordneter eingerichteter Leitwege, wenn die Verkehrsaktivität unter einen vorbestimmten Pegel fällt.
- 15
29. Einrichtung nach einem der Ansprüche 1-28, **dadurch gekennzeichnet, dass** die erste Paketdatenmodus-Beendungsvorrichtung eine Vorrichtung umfasst zum Überwachen der Zeit, die abgelaufen ist seit der Paketdatenmodus für eine Mobilstation eingerichtet worden ist und eine Vorrichtung zum Beenden des Paketdatenmodus und jedes zugeordneten eingerichteten Leitweges, wenn die abgelaufene Zeit eine vorbestimmte Zeitperiode übersteigt.
- 20
30. Mobilstation zur Paketdatenkommunikation über digital-TDMA-zellulare geteilte Paketdatenkanäle, befähigt durch eine Einrichtung gemäß einem der Ansprüche 1-29, wobei die Mobilstation umfasst:
- 25
- Eine erste Kanalidentifizierungsvorrichtung zum Identifizieren der Paketdatenkanäle, die für das Veranlassen von Paketübertragung zu benutzen sind auf einer Pro-Zellen-Basis,
 - Eine zweite Paketdatenmodus-Einrichtungsvorrichtung zum Einrichten eines Paketdatenmodus für die Mobilstationen (MS), um sie zu befähigen, Pakete über die Paketdatenkanäle zu senden und zu empfangen,
 - Eine erste Vorrichtung zum Senden und Empfangen von Paketen über die Paketdatenkanäle,
 - Eine zweite Vorrichtung zum Durchführen von Ortsaktualisierung im Paketdatenmodus,
- 30
- 35
- 40
- 45
- 50
- 55
- Eine zweite Paketdatenmodus-Aufrechterhaltungsvorrichtung zum Aufrechterhalten des Paketsdatenmodus für die Mobilstation (MS), und
 - eine zweite Paketdatenmodusbeendungsvorrichtung zum Beenden des eingerichteten Paketdatenmodus für die Mobilstation (MS),
 - **gekennzeichnet durch**
 - eine zweite Vorrichtung zum Durchführen von Zellenselektion im Paketdatenmodus, wobei die Zellenselektion von der Mobilstation gesteuert wird.
31. Mobilstation nach Anspruch 30, **dadurch gekennzeichnet, dass** die erste Kanalidentifizierungsvorrichtung ausgestaltet ist zum Lesen von Information, die zum Definieren des für das Veranlassen der Paketdatenübertragung zu verwendenden Paketdatenkanals bereitgestellt wird von einem regulären Zellularrundsendesteuerkanal, wenn ein solcher Paketdatenkanal in der betrachteten Zelle bereitgestellt ist.
32. Mobilstation nach Anspruch 30 oder 31, **dadurch gekennzeichnet, dass** die erste Kanalidentifizierungsvorrichtung ausgestaltet ist, um in einem regulären Zellularrundsendesteuerkanal Information zu lesen, die bereitgestellt wird zum Anzeigen, dass ein Datenpaketkanal zum Veranlassen der Paketübertragung auf Anforderung des Benutzers bereitgestellt werden kann.
33. Mobilstation nach einem der Ansprüche 30-32, **dadurch gekennzeichnet, dass** die zweite Vorrichtung zum Durchführen von Zellenselektion ausgestaltet ist zum durchführen von Zellenselektion basierend auf regulären Zellular-Ruhezustandsprozeduren.
34. Mobilstation nach Anspruch 33, **dadurch gekennzeichnet, dass** die zweite Vorrichtung zum Ausführen von Zellenselektion eine Vorrichtung umfasst zum Beibehalten der momentan ausgewählten Zelle so lang wie die Signalqualität oberhalb eines vorbestimmten Schwellwertes ist.
35. Mobilstation nach einem der Ansprüche 30-34, **dadurch gekennzeichnet, dass** die zweite Vorrichtung zum Durchführen von Ortsaktualisierung ausgestaltet ist zum Durchführen von Ortsaktualisierung basierend auf regulären Zellularruhezustandsmodusprozeduren.
36. Mobilstation nach einem der Ansprüche 30-35, **dadurch gekennzeichnet, dass** die zweite Paketda-

tenmodus-Einrichtungsvorrichtung umfasst;

- Eine Vorrichtung zum Veranlassen des Einrichtens von Paketdatenmodus in der Mobilstation (MS) aus einem Anfangszellularruhezustandsmodus entweder durch die eine Paketdatendienstsanfrage generierende Mobilstation (MS) basierend auf regulärer Zellularsteuerkanalsignalisierung oder durch die eine Paging-Meldung empfangende Mobilstation, basierend auf regulärer Zellularsteuerkanalsignalisierung, anzeigend, dass ein an die Mobilstation (MS) adressiertes Paket empfangen worden ist von dem die Mobilstation (MS) momentan bedienenden Mobildienstvermittlungszentrum (MSC),
 - Eine Vorrichtung zum Durchführen einer regulären Zellularauthentifikationsprozedur als nachfolgenden Schritt,
 - Eine Vorrichtung zum Veranlassen von Parametern für Paketverschlüsselung/Entschlüsselung in der Mobilstation (MS), und
 - eine Vorrichtung zum Speichern von Information in der Mobilstation, die anzeigt, dass der Paketdatenmodus eingerichtet ist.
37. Mobilstation nach einem der Ansprüche 30-36, außerdem **gekennzeichnet durch** eine Vorrichtung, um, wenn die Mobilstation sich im Paketdatenmodus befindet und sich in einer Zelle befindet, die auf Anforderung des Benutzers einen Paketdatenkanal zur Verfügung stellt, befindet, eine Paketdatenkanalzuordnungsanfrage zu generieren, basierend auf regulärer Zellularsteuerkanalsignalisierung.
38. Mobilstation nach einem der Ansprüche 30-37, außerdem **gekennzeichnet durch** eine Vorrichtung, um, wenn die Mobilstation sich in Paketdatenmodus befindet und sich in einer Zelle mit zugeordnetem Paketdatenkanal(kanälen) befindet, eine Paketdatenkanalzuordnungsanfrage zu generieren für eine Nachbarzelle, die einen Paketdatenkanal auf Anfrage des Benutzers bereitstellt unter Verwendung eines Paketdatenkanals der momentan bedienenden Zelle, vor dem Bewegen in diese Nachbarzelle.
39. Mobilstation nach einem der Ansprüche 30-38, **dadurch gekennzeichnet, dass** die erste Vorrichtung zum Senden und Empfangen von Paketen eine Vorrichtung umfasst zum Senden eines Mobil/Stationär/Modusindikators an das die Mobilstation momentan bedienende Mobildienstvermittlungszentrum (MSC), zumindest jedes Mal, wenn die Mobilstation von Mobil- zum Stationärmodus wechselt

oder umgekehrt.

40. Mobilstation nach einem der Ansprüche 30-39, **dadurch gekennzeichnet, dass** die erste Vorrichtung zum Senden und Empfangen von Paketen eine Vorrichtung umfasst zum Ansprechen auf einen Paging-Meldungstyp, der eine Paging-Anfrage mit der Reservierung eines individuellen Zugangsschlitzes für die Mobilstation, (MS) zum Antworten kombiniert.
41. Mobilstation nach einem der Ansprüche 30-40, **dadurch gekennzeichnet, dass** die erste Vorrichtung zum Senden und Empfangen von Paketen eine Vorrichtung umfasst zum Ansprechen auf einen regulären Zellular-Ruf betreffendes Paging auf einem Paketdatenkanal.
42. Mobilstation nach einem der Ansprüche 33-41, **dadurch gekennzeichnet, dass** die erste Vorrichtung zum Senden und Empfangen von Paketen und die zweite Vorrichtung zum durchführen von Zellenselektion zum Koordinieren des Hörens auf den Paketdatenkanal, auf dem Paketübertragung zur Mobilstation (MS) veranlasst worden ist mit Durchführen von Zellenselektion, eine Vorrichtung umfasst zum Planen des Mithörens bezüglich Paging / und anderen Meldungen, zum Veranlassen von Paketübertragung zu der Mobilstation (MS) gemäß einem Multi-TDMA-Rahmenschema, synchronisiert mit dem entsprechenden Multirahmenschema, das für die reguläre Zellularsteuerkanalsignalisierung verwendet wird, vorbestimmte Zeiten für die Mobilstation (MS) zulassend zum Durchführen von Zellenselektion und zum Empfangen regulärer Zellularsendemeldungen.
43. Mobilstation nach einem der Ansprüche 30-42, **dadurch gekennzeichnet, dass** die zweite Paketdatenmodus-Aufrechterhaltungsvorrichtung eine Vorrichtung umfasst, um es der Mobilstation zu ermöglichen, reguläre Zellularrufe zu machen und zu empfangen, wenn sie sich im Paketdatenmodus befindet, eine Vorrichtung zum Aufrechterhalten des Paketdatenmodus, als anhängig während eines Rufs und eine Vorrichtung zum Zurückführen der Mobilstation zum Aktivpaketdatenmodus, wenn der Ruf abgeschlossen ist.

Revendications

1. Appareil pour assurer la communication de données par paquets vers des, et en provenance de, stations mobiles (MS) dans un système cellulaire à AMRT (accès multiple à répartition dans le temps) numérique comprenant :

- une pluralité de stations de base (BTS, BSC) fournissant des canaux de contrôle cellulaire réguliers,
 - un ou plusieurs centres de commutation de services mobiles (MSC), chacun étant associé à un registre de localisation de visiteur (VLR) et étant couplé à une pluralité subordonnée desdites stations de base (BTS, BSC), et
 - un moyen de registre de localisation de rattachement (HLR),
 - un premier moyen de fourniture de canal pour fournir, dans au moins certaines desdites stations de base (BTS, BSC), sur une base par cellule, un ou plusieurs canaux de données par paquets partagés pour le transfert de paquets vers et en provenance desdites stations mobiles (MS), et un premier moyen de contrôle de transfert de paquets pour contrôler ledit transfert de paquets,
 - un premier moyen de définition de canal pour définir, sur une base par cellule, le canal de données par paquets à utiliser pour initier un transfert de paquets,
 - un premier moyen d'établissement de mode de données par paquets pour établir un mode de données par paquets pour toute dite station mobile (MS) pour permettre à ladite station mobile (MS) d'envoyer et de recevoir des paquets sur lesdits canaux de données par paquets,
 - un premier moyen de transfert de paquets pour transférer des paquets entre lesdites stations mobiles (MS) et toute station de base (BTS, BSC),
 - un second moyen de transfert de paquets pour transférer des paquets entre lesdites stations de base (BTS, BSC) et leurs centres de commutation de services mobiles (MSC) supérieurs respectifs,
 - un moyen d'acheminement de paquets pour acheminer des paquets vers et en provenance de la zone de service de tout dit centre de commutation de services mobiles (MSC),
 - un premier moyen pour effectuer la mise à jour de localisation pour toute dite station mobile (MS) en mode de données par paquets,
 - un premier moyen de maintien de mode de données par paquets pour maintenir ledit mode de données par paquets pour toute station mobile (MS) itinérante, et
 - un premier moyen de suspension de mode de données par paquets pour suspendre ledit mode de données par paquets établi pour toute dite station mobile (MS), **caractérisé par**
 - un premier moyen pour effectuer une sélection de cellule pour toute dite station mobile en mode de données par paquets, dans lequel la sélection de cellule est contrôlée par ladite station mobile.
2. Appareil selon la revendication 1, **caractérisé en ce que** ledit moyen de définition de canal comprend un premier moyen de fourniture d'informations pour fournir, sur un canal de contrôle de diffusion cellulaire régulier, une information définissant le canal de données par paquets à utiliser pour initier le transfert de paquets, si un tel canal de données par paquets est fourni dans la cellule en question ;
 3. Appareil selon la revendication 1 ou 2, **caractérisé en ce que** ledit moyen de définition de canal comprend un second moyen de fourniture d'informations pour fournir, sur un canal de contrôle de diffusion cellulaire régulier, une information indiquant qu'un canal de données par paquets pour initier un transfert de paquets peut être fourni par ledit moyen de fourniture de canal à la demande de l'utilisateur.
 4. Appareil selon l'une quelconque des revendications 1 à 3, **caractérisé en ce que** ledit moyen pour effectuer la sélection de cellule est adapté pour effectuer une sélection de cellule sur la base de procédures de mode inactif cellulaire régulier.
 5. Appareil selon la revendication 4, **caractérisé en ce que** ledit moyen pour effectuer une sélection de cellule comprend un moyen pour conserver la cellule actuellement sélectionnée aussi longtemps que la qualité du signal est au-dessus d'une valeur de seuil prédéfinie.
 6. Appareil selon l'une quelconque des revendications 1 à 5, **caractérisé en ce que** ledit premier moyen pour effectuer la mise à jour de localisation est adapté pour effectuer la mise à jour de localisation sur la base de procédures de mode inactif cellulaire régulier.
 7. Appareil selon l'une quelconque des revendications 1 à 6, **caractérisé en ce que** ledit premier moyen d'établissement de mode de données par paquets comprend :
 - un moyen pour initier ledit établissement de mode de données par paquets pour une station mobile (MS), à partir d'un mode inactif cellulaire initial, soit par la station mobile (MS) générant une requête de service de données par paquets, sur la base d'une signalisation de canal de contrôle cellulaire régulier, soit par le centre de commutation de services mobiles (MSC) desservant actuellement ladite station mobile (MS), recevant un paquet adressé à la station mobile (MS) suivi d'un appel de recherche de personne sur la base d'une signalisation de canal de contrôle cellulaire régulier,
 - un moyen pour effectuer, en tant qu'étape sui-

- vante, une procédure d'authentification cellulaire régulière,
- un moyen pour initier des paramètres pour le cryptage/décryptage de paquets entre la station mobile (MS) et son centre de commutation de services mobiles actuel (MSC), et 5
 - un moyen pour enregistrer la station mobile à son centre de commutation de services mobiles (MSC) actuel dans le registre de localisation de visiteur (VLR) associé se trouvant en mode de données par paquets. 10
8. Appareil selon l'une quelconque des revendications 1 à 7, **caractérisé en ce que** ledit premier moyen de fourniture de canal comprend 15
- un moyen pour allouer, à partir d'un groupe commun de canaux physiques, une combinaison variable de canaux de données par paquets et de canaux de trafic cellulaire réguliers déterminée à la demande, 20
 - un moyen pour affecter le premier canal de données par paquets alloué à une cellule comme canal pour initier un transfert de paquets, capable d'acheminer une signalisation de contrôle d'accès, de même que des données par paquets, et 25
 - un moyen pour affecter tout (tous) canal (canaux) de données par paquets alloué(s) supplémentaire(s) comme canal (canaux) pour un transfert de paquets réservé. 30
9. Appareil selon la revendication 8, **caractérisé en ce que** ledit premier moyen de fourniture de canal est adapté pour allouer ledit premier canal de données par paquets à une cellule à la demande de l'utilisateur, et comprend 35
- un moyen pour allouer un canal de données par paquets par l'effet de l'établissement d'un mode de données par paquets réussi, et 40
 - un moyen pour allouer un canal de données par paquets, initié par une station mobile en mode de données par paquets générant une requête d'allocation de canal de données par paquets, ou initié par l'effet d'un appel de recherche de personne réussi vers une station mobile en mode de données par paquets, dans l'un ou l'autre cas sur la base d'une signalisation de canal de contrôle cellulaire régulier. 45
10. Appareil selon la revendication 8 ou 9, **caractérisé en ce que** ledit premier moyen de fourniture de canal est adapté pour allouer ledit premier canal de données par paquets à une cellule à la demande de l'utilisateur, et comprend un moyen pour allouer un canal de données par paquets, initié par une station mobile en mode de données par paquets gé-
- nérant une requête d'allocation de canal de données par paquets pour la cellule en question préalablement au déplacement dans ladite cellule, utilisant un canal de données par paquets d'une cellule adjacente actuellement en service.
11. Appareil selon l'une quelconque des revendications 8 à 10, **caractérisé en ce que** ledit premier moyen de fourniture de canal comprend
- un moyen pour mesurer la charge de trafic sur tout canal de données par paquets alloué,
 - un moyen pour allouer dynamiquement un nombre variable desdits canaux pour un transfert de paquets réservé, sur la base de mesures de charge de trafic et la disponibilité desdits canaux physiques.
12. Appareil selon la revendication 11, **caractérisé en ce que** ledit premier moyen de fourniture de canal comprend en outre
- un moyen pour allouer dynamiquement un nombre variable desdits canaux de données par paquets pour initier un transfert de paquets, de telle sorte qu'un groupe de ces canaux peut être utilisé en association avec un groupe commun de canaux de données par paquets pour un transfert de paquets réservé, et
 - un moyen pour diriger toute station mobile (MS) vers l'un desdits canaux de données par paquets en particulier pour initier un transfert de paquets, si plus d'un tel canal est alloué, sur la base de l'identité d'une station mobile et d'une information de contrôle diffusée.
13. Appareil selon l'une quelconque des revendications 1 à 12, **caractérisé en ce que** lesdits moyens de transfert de paquets, pour initier un transfert de paquets vers une station mobile (MS) en mode de données par paquets, comprennent un moyen de recherche de personne et un moyen de surveillance pour surveiller la localisation cellulaire de la station mobile (MS) sur la base de tout transfert de paquets préalable, et **caractérisé en outre en ce que** lesdits moyens de transfert de paquets sont adaptés pour permettre l'utilisation d'une recherche de personne guidée par ledit moyen de surveillance pour initier un transfert de paquets vers une station mobile (MS).
14. Appareil selon la revendication 13, **caractérisé en ce que** ledit moyen de surveillance comprend
- un moyen pour identifier la localisation cellulaire d'une station mobile (MS) émettant un paquet, lorsque le paquet est reçu au niveau du centre de commutation de services mobiles

- (MSC) desservant actuellement la station mobile, en associant le paquet à l'identité, pour chaque cellule unique, de la connexion sur laquelle le paquet est reçu,
- un moyen pour identifier la localisation cellulaire d'une station mobile répondant à un message d'appel à personne, et
 - un moyen pour mémoriser, pour une station mobile (MS), en liaison avec son enregistrement en mode paquet, au moins la dernière localisation cellulaire identifiée et un moment associé lorsque la localisation cellulaire a été identifiée.
15. Appareil selon la revendication 13 ou 14, **caractérisé en ce que** lesdits moyens de transfert de paquets, pour initier un transfert de paquets vers une station mobile (MS), comprennent en outre un moyen pour surveiller un indicateur de mode mobile/fixe envoyé par une station mobile (MS), capable de fonctionner en mode fixe, vers son centre de commutation de services mobiles (MSC) actuellement en service au moins chaque fois qu'il passe du mode mobile au mode fixe ou inversement.
16. Appareil selon la revendication 15, **caractérisé en ce que** lesdits moyens de transfert de paquets sont adaptés pour, vers une station mobile (MS) qui est en mode fixe et effectue une sélection de cellule selon la revendication 5, initier un transfert de paquets sans recherche de personne préalable ou avec recherche de personne dans une cellule unique.
17. Appareil selon l'une quelconque des revendications 13 à 16, **caractérisé en ce que** lesdits moyens de transfert de paquets sont adaptés pour, également vers une station mobile (MS) qui est en mode mobile et effectue une sélection de cellule selon la revendication 5, initier un transfert de paquets sans recherche de personne préalable ou avec recherche de personne dans une cellule unique, à condition que l'information de localisation cellulaire à partir dudit moyen de surveillance remplisse des critères de précision prédéfinis.
18. Appareil selon l'une quelconque des revendications 1 à 17, **caractérisé en ce que** lesdits moyens de transfert de paquets, pour initier un transfert de paquets vers des stations mobiles (MS) en mode de données par paquets, comprennent un moyen de recherche de personne adapté pour inclure un type de message de recherche de personne, combinant une (des) requête(s) d'appel à personne avec une (des) réservation(s) de fentes d'accès individuel pour permettre à la (aux) station(s) mobile(s) (MS) de répondre.
19. Appareil selon l'une quelconque des revendications
- 1 à 18, **caractérisé en ce que** lesdits moyens de transfert de paquets comprennent un moyen d'appel à personne adapté pour acheminer, sur un canal de données par paquets, un appel à personne relié à un appel cellulaire régulier vers une station mobile (MS) en mode de données par paquets.
20. Appareil selon l'une quelconque des revendications 4 à 19, **caractérisé en ce que** ledit premier moyen de transfert de paquets et ledit moyen pour effectuer une sélection de cellule, pour coordonner l'initiation de transferts de paquets vers des stations mobiles (MS) en effectuant une sélection de cellule dans lesdites stations mobiles (MS), comprennent un moyen pour programmer l'appel à personne et d'autres messages, initier des transferts de paquets vers des stations mobiles (MS), conformément à un schéma à trames AMRT multiples, synchronisé avec les schémas à trames multiples correspondants utilisés pour la signalisation de canal de contrôle cellulaire régulier, en permettant un nombre de fois prédéfini pour les stations mobiles (MS) pour effectuer la sélection de cellule et pour recevoir des messages de diffusion cellulaire réguliers.
21. Appareil selon l'une quelconque des revendications 1 à 20, **caractérisé en ce que** ledit premier moyen de maintien de mode de données de paquets comprend un moyen pour permettre à une station mobile (MS), en mode de données par paquets, d'établir et de recevoir des appels cellulaires réguliers, un moyen pour maintenir le mode de données par paquets en attente pendant un appel, et un moyen pour ramener la station mobile en mode de données par paquets actif lorsque l'appel est terminé.
22. Appareil selon l'une quelconque des revendications 1 à 21, **caractérisé en ce que** ledit moyen d'acheminement de paquets comprend
- un ou plusieurs moyens à fonction interactive (IWF) pour agir en interconnexion de réseaux avec un (des) réseau(x) externe(s),
 - un moyen d'interconnexion pour interconnecter ledit moyen à fonction interactive (IWF) et des centres de commutation de services mobiles (MSC), et
 - un moyen pour acheminer des paquets adressés à une station mobile (MS) à partir de tout dit moyen à fonction interactive (IWF), vers le centre de commutation de services mobiles (MSC) desservant actuellement ladite station mobile, comprenant, pour établir un chemin vers ledit centre de commutation de services mobiles (MSC),
 - un moyen pour interroger initialement un registre de localisation de rattachement (HLR) pour déterminer l'identité dudit centre de commuta-

- tion de services mobiles (MSC),
- au niveau dudit moyen à fonction interactive (IWF), un moyen pour mémoriser, en liaison avec l'identité de ladite station mobile, l'identité dudit centre de commutation de services mobiles (MSC), 5
 - au niveau dudit centre de commutation de services mobiles (MSC), un moyen pour initier, comme requis, l'établissement du mode de données par paquets pour ladite station mobile, et un moyen pour déterminer et mémoriser, en liaison avec l'enregistrement en mode de données par paquets de ladite station mobile, l'identité dudit moyen à fonction interactive (IWF). 10
23. Appareil selon l'une quelconque des revendications 1 à 22, **caractérisé en ce que** ledit moyen d'acheminement de paquets comprend 15
- un moyen d'interconnexion pour interconnecter des centres de commutation de services mobiles (MSC), et 20
 - un moyen pour acheminer des paquets provenant d'une première station mobile (MS1) et adressés à une seconde station mobile (MS2) comprenant : 25
 - au niveau du centre de commutation de services mobiles desservant actuellement la première station mobile, un moyen pour déterminer, à partir d'une information d'acheminement mémorisée, si un chemin vers le centre de commutation de services mobiles desservant actuellement la seconde station mobile est établi, en liaison avec un enregistrement en mode de données par paquets de la première station mobile ; un moyen pour acheminer des paquets vers le centre de commutation de services mobiles desservant actuellement la seconde station mobile lorsqu'un chemin est établi ; et un moyen pour interroger initialement le moyen de registre de localisation de rattachement pour déterminer une identité du centre de commutation de services mobiles desservant actuellement la seconde station mobile lorsqu'un chemin n'est pas établi et pour mémoriser, sous forme d'information d'acheminement, l'identité du centre de commutation desservant actuellement la seconde station mobile avec l'identité de la seconde station mobile, en liaison avec l'enregistrement en mode de données par paquets de la première station mobile ; et 30
 - au niveau du centre de commutation de services mobiles desservant actuellement 35
 - ladite seconde station mobile (MS2), un moyen pour initier l'établissement d'un mode de données par paquets pour ladite seconde station mobile (MS2) lorsque le mode de données par paquets n'est pas déjà établi, et un moyen pour déterminer et mémoriser, en liaison avec l'enregistrement en mode de données par paquets de ladite seconde station mobile (MS2), l'identité de ladite première station mobile (MS1) et de son centre de commutation de services mobiles actuel. 40
24. Appareil selon l'une quelconque des revendications 1 à 21, **caractérisé en ce que** ledit moyen d'acheminement de paquets comprend 45
- un moyen d'interconnexion pour interconnecter des centres de commutation de services mobiles (MSC), et pour connecter des centres de commutation de services mobiles à un (des) réseau(x) externe(s), directement ou via un moyen à fonction interactive distinct (IWF), 50
 - un moyen pour acheminer des paquets adressés à une station mobile (MS) à partir d'un (de) réseau(x) externe(s) ou d'une (d') autre(s) station(s) mobile(s), vers un centre de commutation de services mobiles prédéterminé (MSC) auquel la station mobile appartient du point de vue de l'adressage, et 55
 - un moyen pour acheminer des paquets adressés à une station mobile à partir dudit centre de commutation de services mobiles prédéterminé vers le (identique ou différent) centre de commutation de services mobiles desservant actuellement ladite station mobile, comprenant au niveau du centre de commutation de services mobiles adressé, un moyen pour déterminer, à partir d'une information d'acheminement mémorisée, si un chemin vers le centre de commutation de services mobiles desservant actuellement la station mobile est établi, en liaison avec une identité de la station mobile ; un moyen pour acheminer des paquets jusqu'au centre de commutation de services mobiles actuellement en service lorsqu'un chemin est établi ; et un moyen pour interroger initialement le moyen de registre de localisation de rattachement, lorsqu'un chemin n'est pas établi, pour déterminer une identité du centre de commutation de services mobiles actuellement en service, et pour mémoriser, sous forme d'information d'acheminement, l'identité du centre de commutation de services mobiles actuellement en service, en liaison avec l'identité de la station mobile ; et 60
 - au niveau dudit centre de commutation de services mobiles actuellement en service, un 65

moyen pour initier, comme requis, l'établissement d'un mode de données par paquets pour ladite station mobile lorsque le mode de données par paquets n'est pas déjà établi, et un moyen pour déterminer et mémoriser, en liaison avec l'enregistrement en mode de données par paquets de ladite station mobile, l'identité dudit centre de commutation de services mobiles prédéterminé.

25. Appareil selon l'une quelconque des revendications 1 à 24, **caractérisé en ce que** ledit premier moyen de maintien de mode de données par paquets, pour maintenir un mode de données par paquets pour une station mobile, lorsqu'elle se déplace vers une zone de localisation appartenant à un nouveau centre de commutation de services mobiles (MSC), comprend un moyen pour transférer l'enregistrement en mode de données par paquets et des informations associées, mémorisées au niveau du centre de commutation de services mobiles (MSC) desservant actuellement la station mobile (avec le registre de localisation de visiteur (VLR) associé), à partir de l'ancien centre de commutation de services mobiles vers le nouveau centre de commutation de services mobiles.

26. Appareil selon l'une quelconque des revendications 22 à 25, **caractérisé en ce que** ledit moyen d'acheminement de paquets, pour maintenir les chemins établis vers un centre de commutation de services mobiles (MSC) desservant actuellement une station mobile, lorsque la station mobile se déplace vers une zone de localisation appartenant à un nouveau centre de commutation de services mobiles, comprend un moyen pour mettre à jour des entités homologues - un moyen à fonction interactive (IWF) et/ou des centres de commutation de services mobiles (MSC) - de tout chemin établi lors du changement de centre de commutation de services mobiles desservant actuellement la station mobile.

27. Appareil selon l'une quelconque des revendications 22 à 26, **caractérisé en ce que** ledit moyen d'acheminement de paquets comprend

- au niveau d'un centre de commutation de services mobiles desservant actuellement une station mobile (MSC), un moyen pour surveiller, eu égard à l'activité de trafic, tout chemin établi vers ledit centre de commutation de services mobiles, en liaison avec l'identité de ladite station mobile, et un moyen pour initier la suspension dudit chemin lorsque l'activité de trafic tombe en dessous d'un niveau prédéterminé, et
- au niveau de l'entité homologue - moyen à fonction interactive ou centre de commutation

de services mobiles - de tout dit chemin, un moyen pour annuler l'information d'acheminement associée, mémorisée au niveau de ladite entité, lorsque la suspension dudit chemin est initiée.

28. Appareil selon l'une quelconque des revendications 1 à 27, **caractérisé en ce que** ledit premier moyen de suspension de mode de données par paquets comprend un moyen pour surveiller une station mobile, eu égard à l'activité de trafic, et un moyen pour suspendre le mode de données par paquets et tous chemins associés établis lorsque l'activité de trafic tombe en dessous d'un niveau prédéterminé.

29. Appareil selon l'une quelconque des revendications 1 à 28, **caractérisé en ce que** ledit premier moyen de suspension de mode de données par paquets comprend un moyen pour surveiller le temps écoulé depuis que le mode de données par paquets a été établi pour une station mobile, et un moyen pour suspendre le mode de données par paquets et tous chemins associés établis lorsque le temps écoulé dépasse une période prédéterminée.

30. Station mobile pour communication de données par paquets sur des canaux de données par paquets partagés cellulaires à AMRT numérique équipé d'un appareil selon l'une quelconque des revendications 1 à 29, ladite station mobile comprenant :

- un premier moyen d'identification de canal pour identifier, sur une base par cellule, le canal de données par paquets à utiliser pour initier un transfert de paquets,
- un second moyen d'établissement de mode de données par paquets pour établir le mode de données par paquets pour la station mobile (MS) afin de lui permettre d'envoyer et de recevoir des paquets sur lesdits canaux de données par paquets,
- un premier moyen pour envoyer et pour recevoir des paquets sur lesdits canaux de données par paquets,
- un second moyen pour effectuer une mise à jour de localisation en mode de données par paquets,
- un second moyen de maintien de mode de données par paquets pour maintenir ledit mode de données par paquets pour la station mobile (MS), et
- un second moyen de suspension de mode de données par paquets pour suspendre ledit mode de données par paquets établi pour ladite station mobile (MS), **caractérisé par**
- un second moyen pour effectuer la sélection de cellule en mode de données par paquets, dans lequel la sélection de cellule est contrôlée par

la station mobile.

31. Station mobile selon la revendication 30, **caractérisée en ce que** ledit premier moyen d'identification de canal est adapté pour extraire, à partir d'un canal de contrôle de diffusion cellulaire régulier, une information fournie pour définir le canal de données par paquets à utiliser pour initier le transfert de paquets, si un tel canal de données par paquets est fourni dans la cellule en question. 5 10
32. Station mobile selon la revendication 30 ou 31, **caractérisée en ce que** ledit premier moyen d'identification de canal est adapté pour extraire, à partir d'un canal de contrôle de diffusion cellulaire régulier, une information fournie pour indiquer qu'un canal de données par paquets pour initier un transfert de paquets peut être fourni à la demande de l'utilisateur. 15 20
33. Station mobile selon l'une quelconque des revendications 30 à 32, **caractérisée en ce que** ledit second moyen pour effectuer une sélection de cellule est adapté pour effectuer une sélection de cellule sur la base de procédures de mode inactif cellulaire régulier. 25
34. Station mobile selon la revendication 33, **caractérisée en ce que** ledit second moyen pour effectuer une sélection de cellule comprend un moyen pour maintenir la cellule actuellement sélectionnée aussi longtemps que la qualité du signal est au-dessus d'une valeur de seuil prédéfinie. 30
35. Station mobile selon l'une quelconque des revendications 30 à 34, **caractérisée en ce que** ledit second moyen pour effectuer la mise à jour de localisation est conçu pour effectuer une mise à jour de localisation sur la base de procédures de mode inactif cellulaire régulier. 35 40
36. Station mobile selon l'une quelconque des revendications 30 à 35, **caractérisée en ce que** ledit second moyen d'établissement de mode de données par paquets comprend 45
- un moyen pour initier ledit établissement de mode de données par paquets dans la station mobile (MS), à partir d'un mode inactif cellulaire initial, soit par la station mobile (MS) générant une requête de service de données par paquets sur la base d'une signalisation de canal de contrôle cellulaire régulier, soit par la station mobile recevant un message de recherche de personne, sur la base d'une signalisation de canal de contrôle cellulaire régulier, indiquant qu'un paquet, adressé à la station mobile (MS), est reçu par le centre de commutation de ser-
- vices mobiles (MSC) desservant actuellement la station mobile (MS)
- un moyen pour effectuer, en tant qu'étape suivante, une procédure d'authentification cellulaire régulière,
 - un moyen pour initier les paramètres pour le cryptage/décryptage de paquets dans la station mobile (MS), et
 - un moyen pour mémoriser, dans la station mobile, l'information indiquant que le mode de données par paquets est établi.
37. Station mobile selon l'une quelconque des revendications 30 à 36, **caractérisée en outre par** un moyen pour, lorsque la station mobile se trouve en mode de données par paquets et est située dans une cellule fournissant un canal de données par paquets sur demande de l'utilisateur, générer une requête d'allocation de canal de données par paquets, sur la base d'une signalisation de canal de contrôle cellulaire régulier. 50
38. Station mobile selon l'une quelconque des revendications 30 à 37, **caractérisée en outre par** un moyen pour, lorsque la station mobile se trouve en mode de données par paquets et est située dans une cellule ayant un ou plusieurs canaux de données par paquets alloués, générer une requête d'allocation de canal de données par paquets pour une cellule adjacente, fournissant un canal de données par paquets à la demande de l'utilisateur, préalablement à un déplacement dans ladite cellule adjacente, utilisant un canal de données par paquets de la cellule actuellement en service. 55
39. Station mobile selon l'une quelconque des revendications 30 à 38, **caractérisée en ce que** ledit premier moyen pour envoyer et recevoir des paquets comprend un moyen pour envoyer un indicateur de mode mobile/fixe au centre de commutation de services mobiles (MSC) desservant actuellement la station mobile, au moins chaque fois que la station mobile passe du mode mobile en mode fixe ou inversement.
40. Station mobile selon l'une quelconque des revendications 30 à 39, **caractérisée en ce que** ledit premier moyen pour envoyer et recevoir des paquets comprend un moyen pour répondre à un type de message de recherche de personne, combinant la requête de recherche de personne avec la réservation d'une fente d'accès individuel pour permettre à la station mobile (MS) de répondre.
41. Station mobile selon l'une quelconque des revendications 30 à 40, **caractérisée en ce que** ledit premier moyen pour envoyer et recevoir des paquets comprend un moyen pour répondre à un appel de

recherche de personne, sur un canal de données par paquets, en relation avec un appel cellulaire régulier.

42. Station mobile selon l'une quelconque des revendications 33 à 41, **caractérisée en ce que** ledit premier moyen pour envoyer et recevoir des paquets et ledit second moyen pour effectuer une sélection de cellule, pour coordonner l'écoute du canal de données par paquets sur lequel les transferts de paquets vers la station mobile (MS) sont initiés en effectuant une sélection de cellule, comprennent un moyen pour programmer l'écoute d'appels de recherche de personne et d'autres messages, initiant les transferts de paquets vers la station mobile (MS), conformément à un schéma à trames AMRT multiples, synchronisé avec les schémas à trames multiples correspondants utilisés pour la signalisation de canal de contrôle cellulaire régulier, permettant un nombre de fois prédéfini pour que la station mobile (MS) effectue une sélection de cellule et pour recevoir des messages de diffusion cellulaire réguliers. 5
10
15
20
43. Station mobile selon l'une quelconque des revendications 30 à 42, **caractérisée en ce que** ledit second moyen de maintien de mode de données par paquets comprend un moyen pour permettre à la station mobile d'effectuer et de recevoir des appels cellulaires réguliers lorsqu'elle se trouve en mode de données par paquets, un moyen pour maintenir le mode de données par paquets en attente pendant un appel, et un moyen pour ramener la station mobile en mode de données par paquets actif lorsque l'appel est terminé. 25
30
35

40

45

50

55

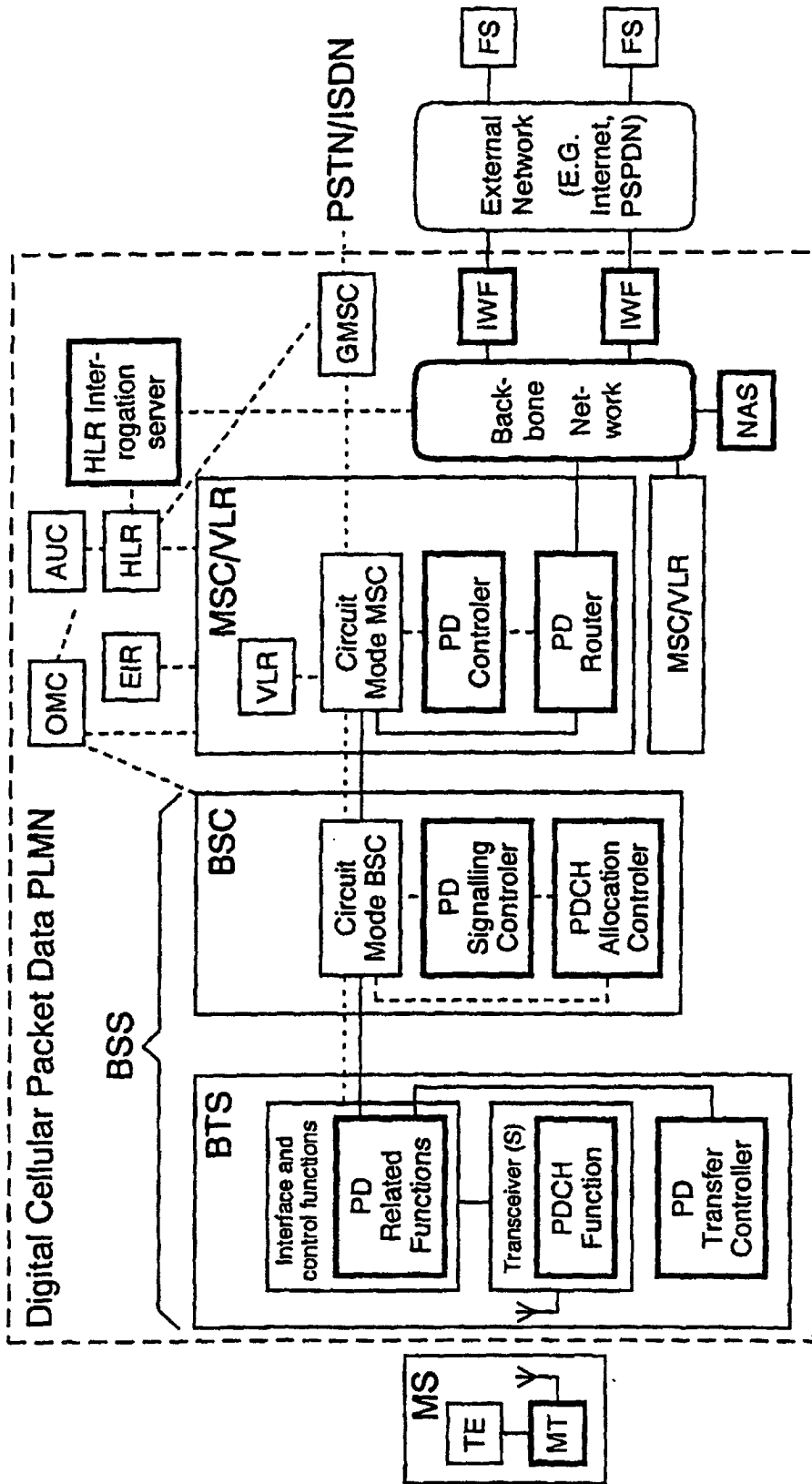

Fig. 1

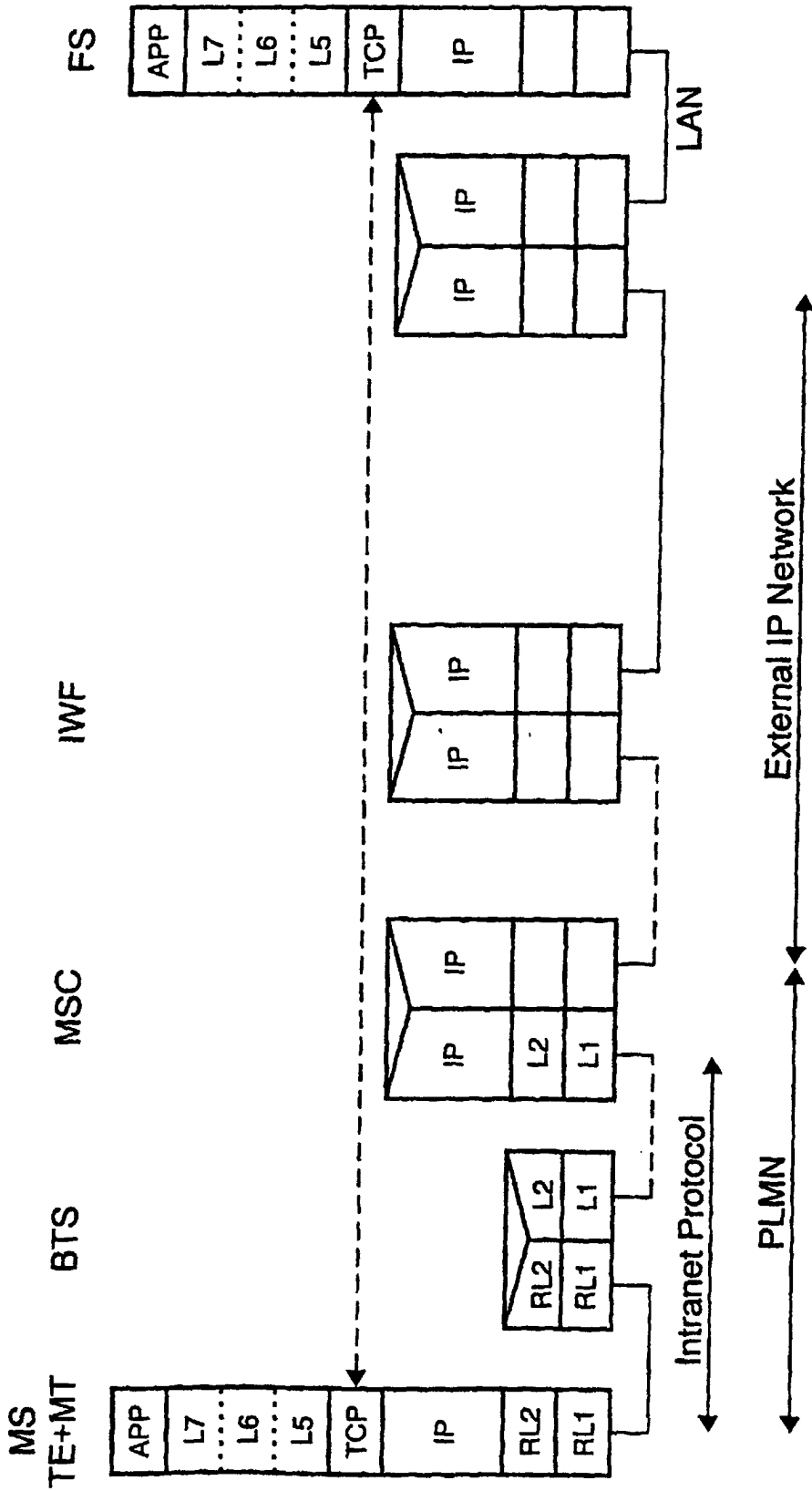

Fig. 2

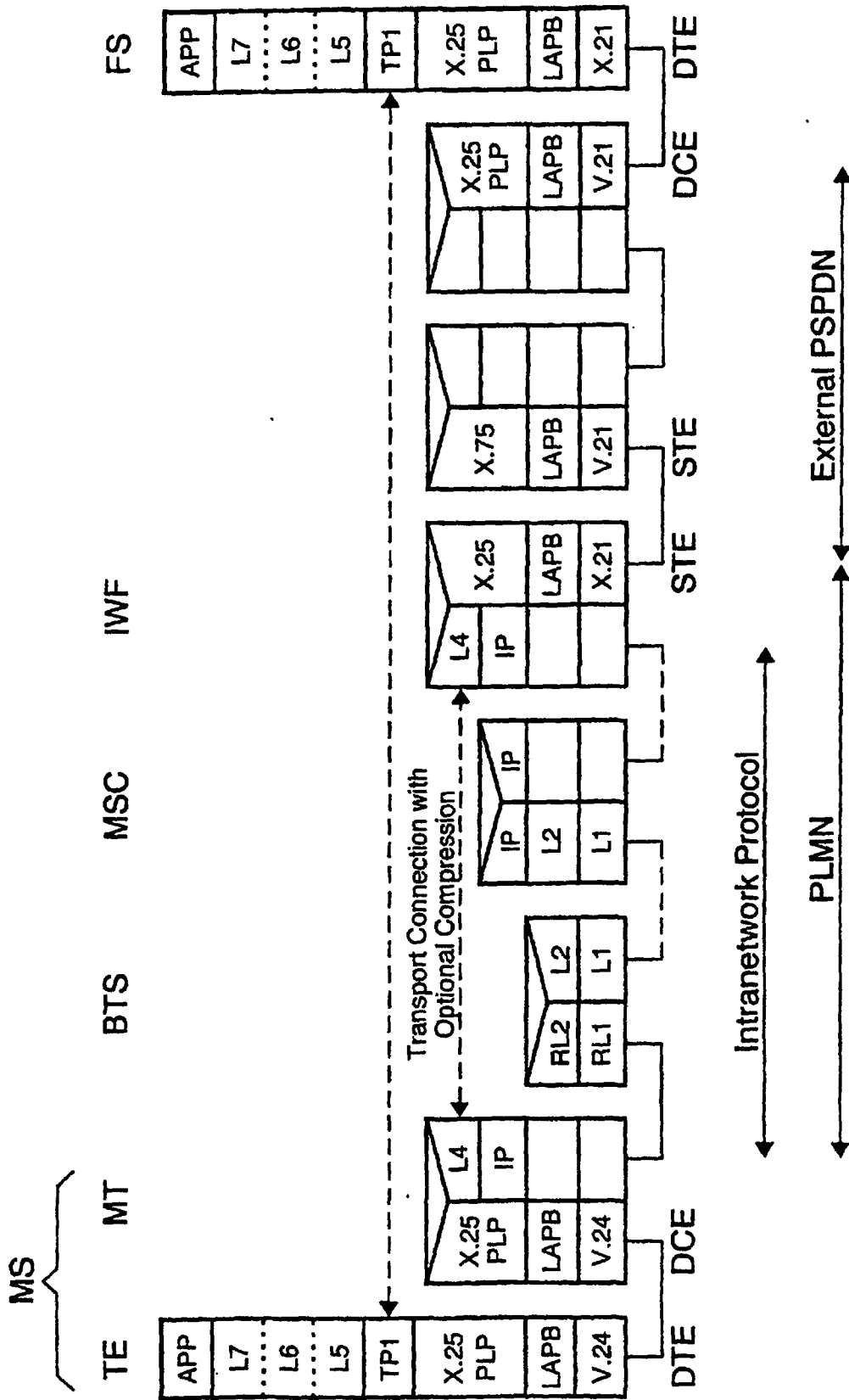

Fig. 3

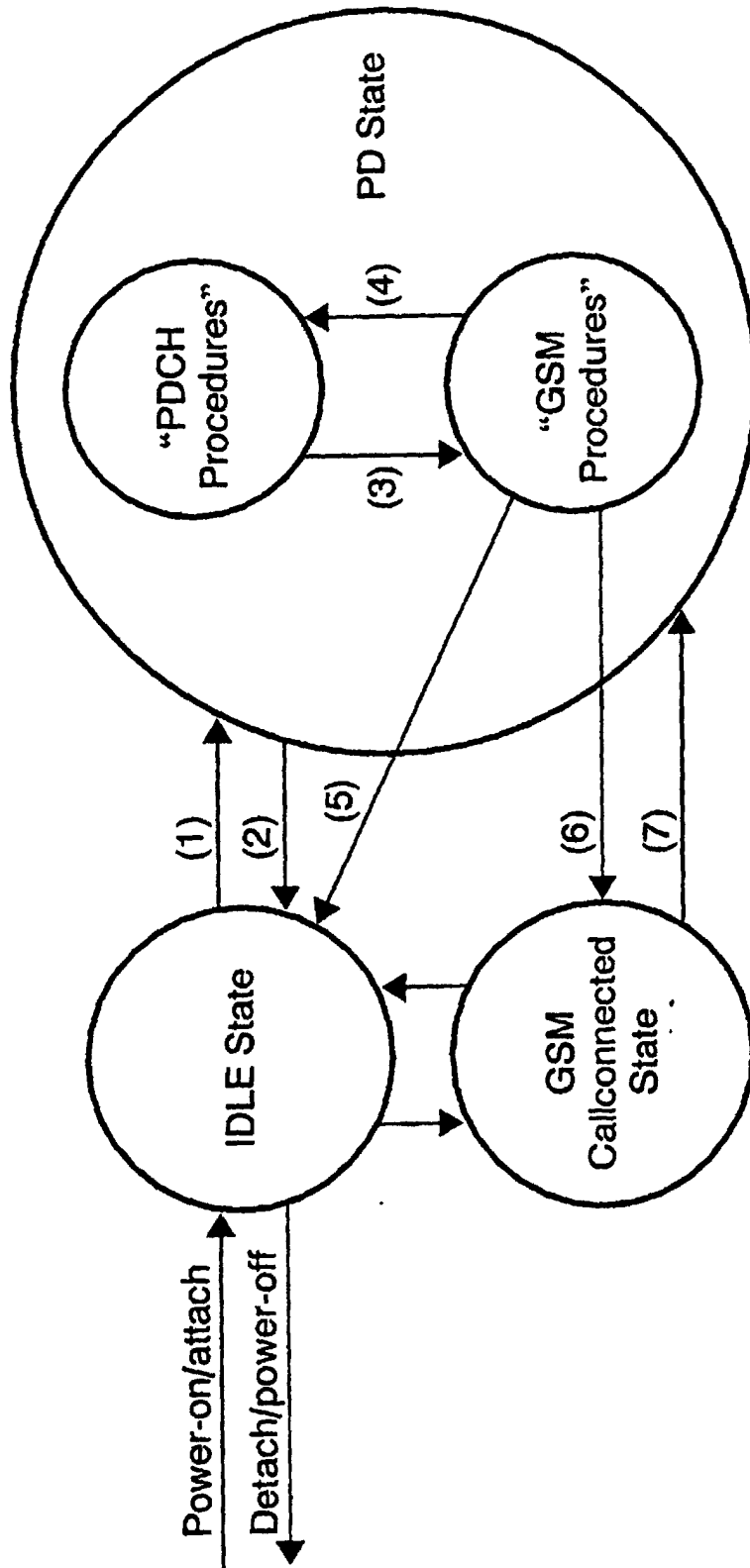

Fig. 4

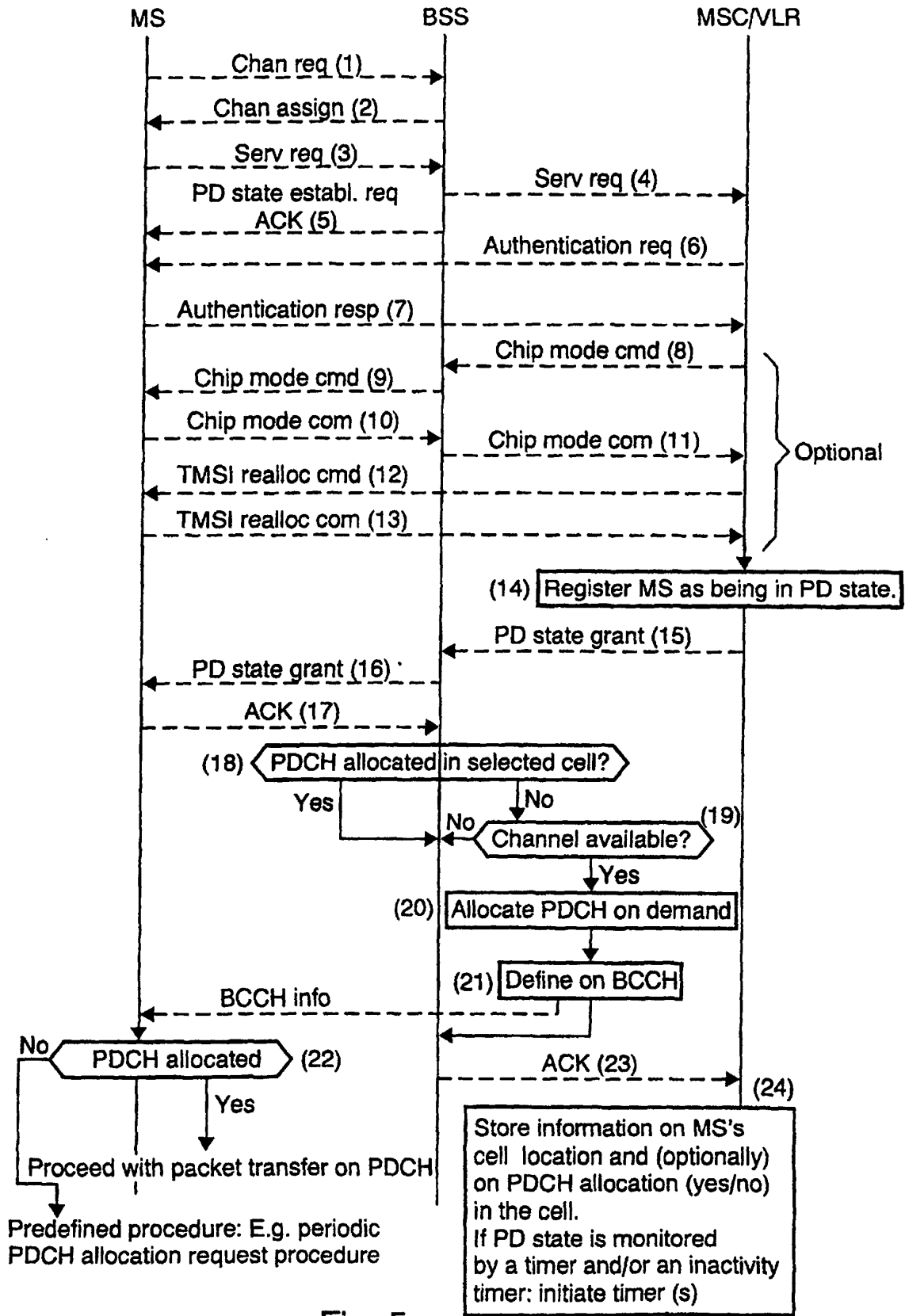

Fig. 5

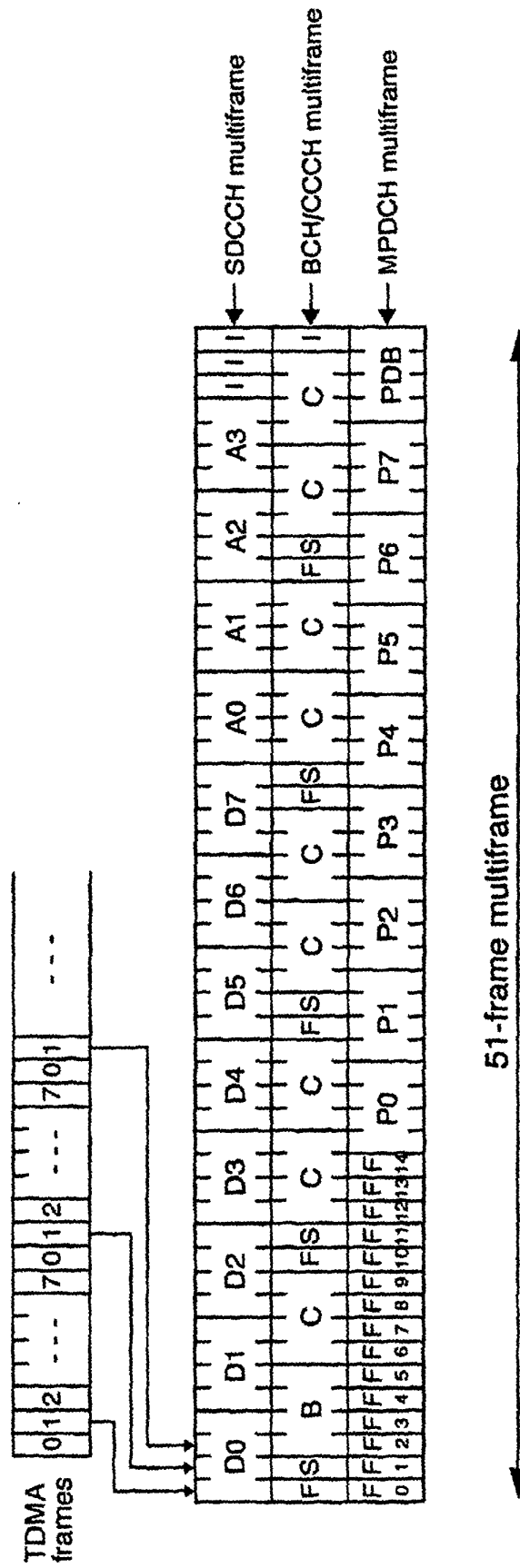

Fig. 6

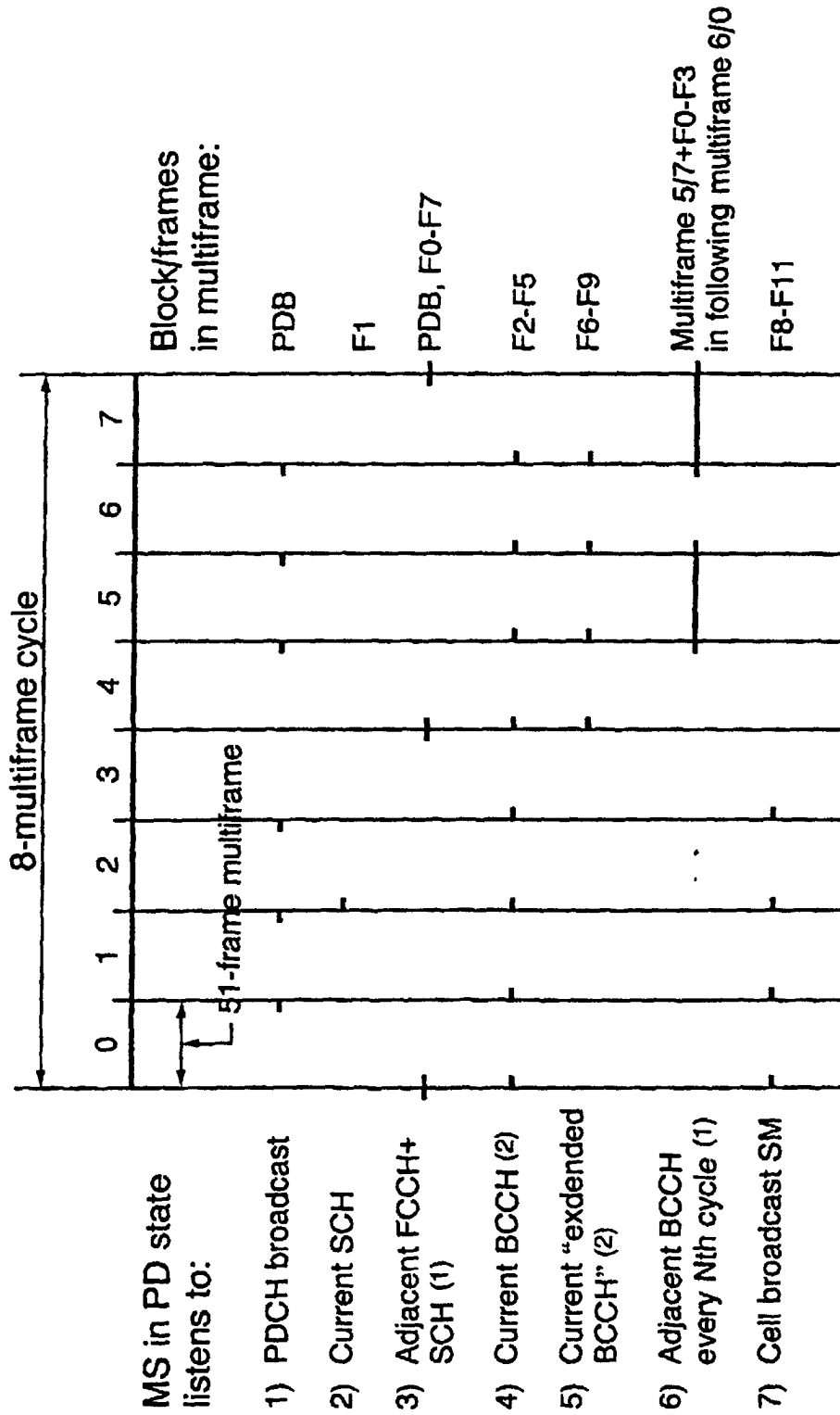

Fig. 7

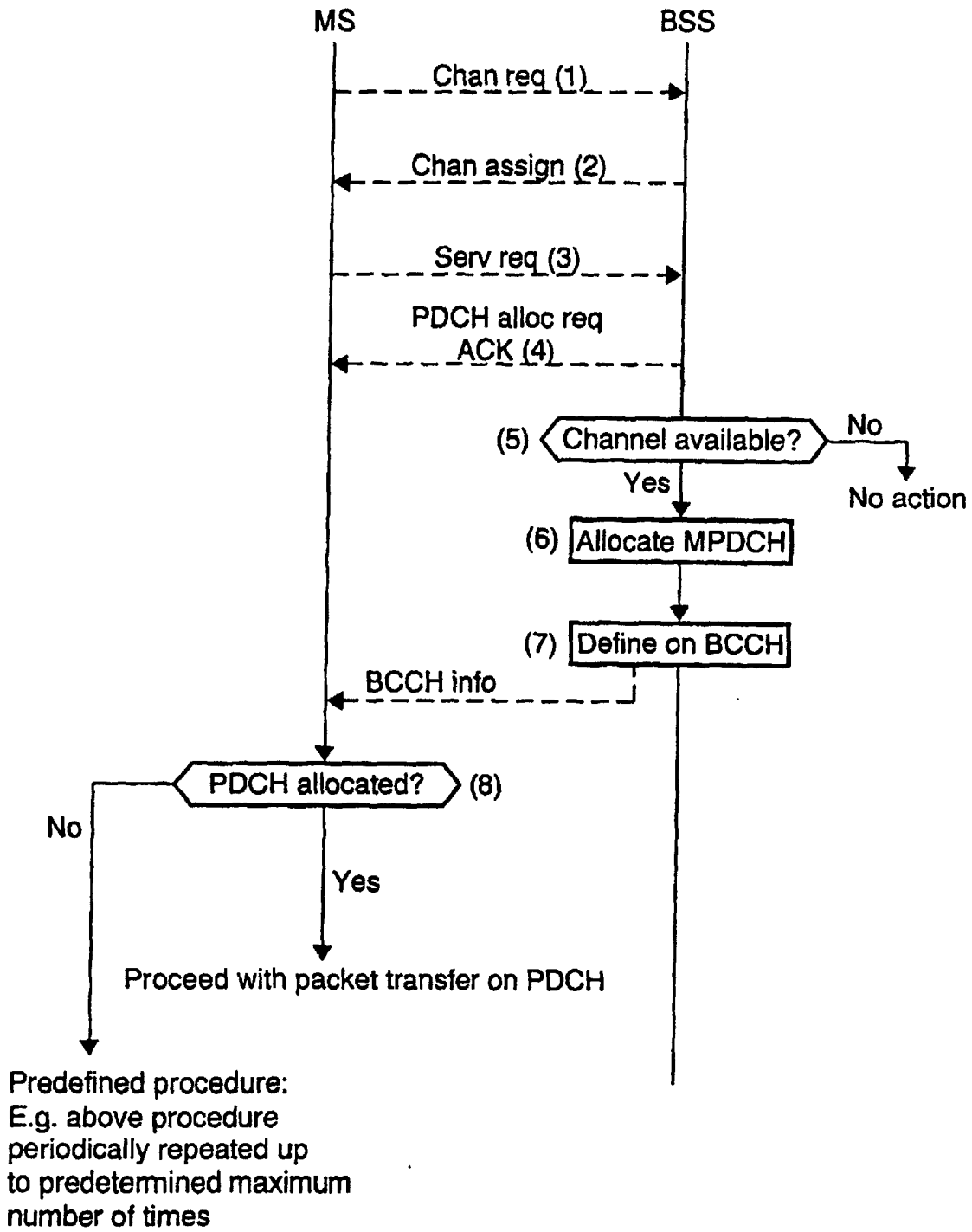

Fig. 8

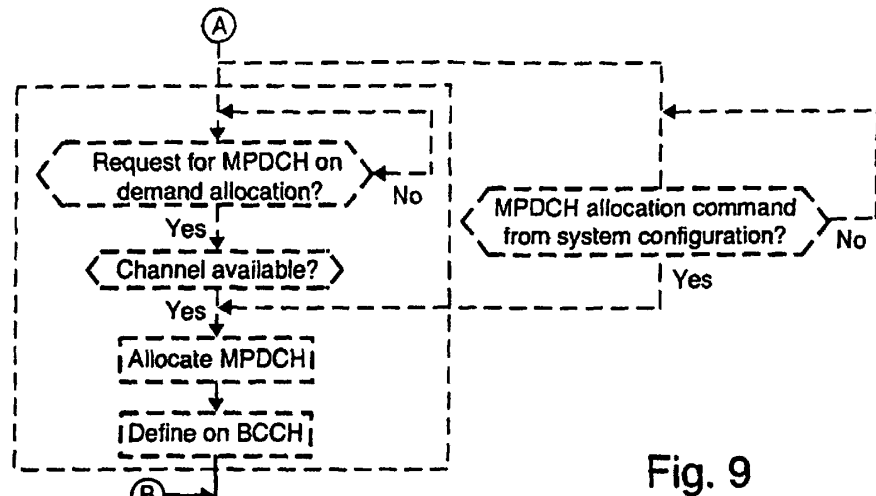
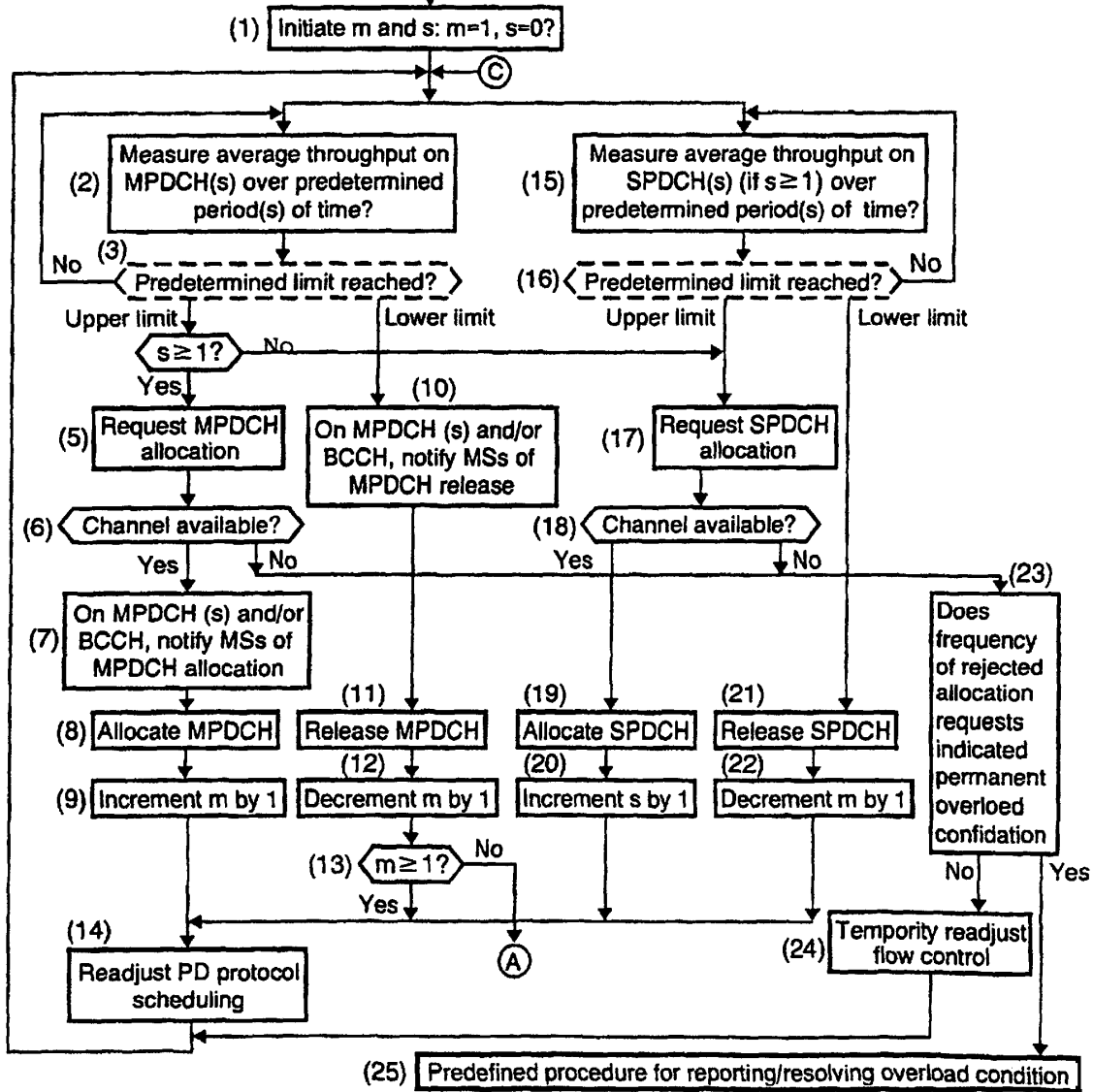

Fig. 9



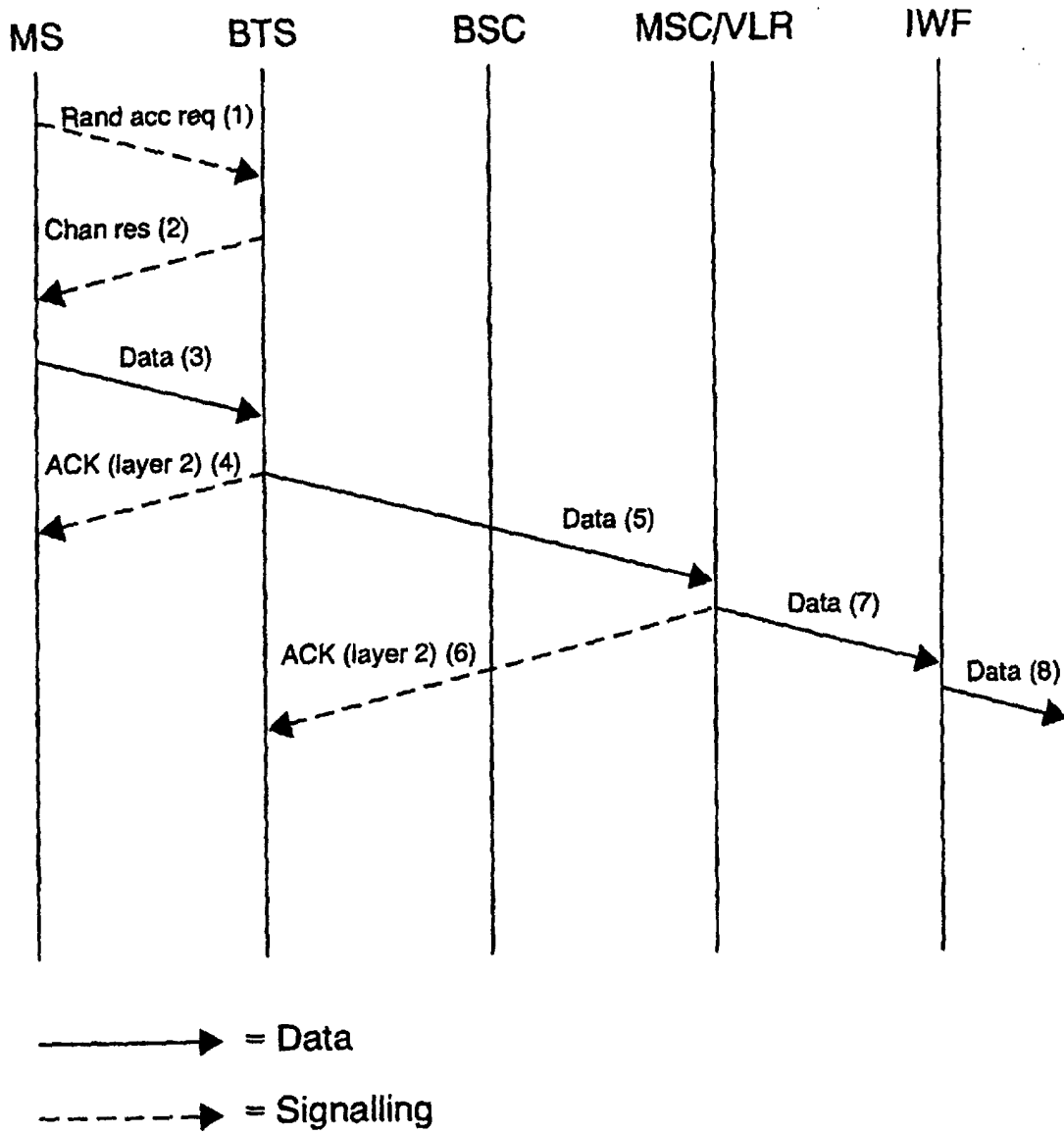

Fig. 10

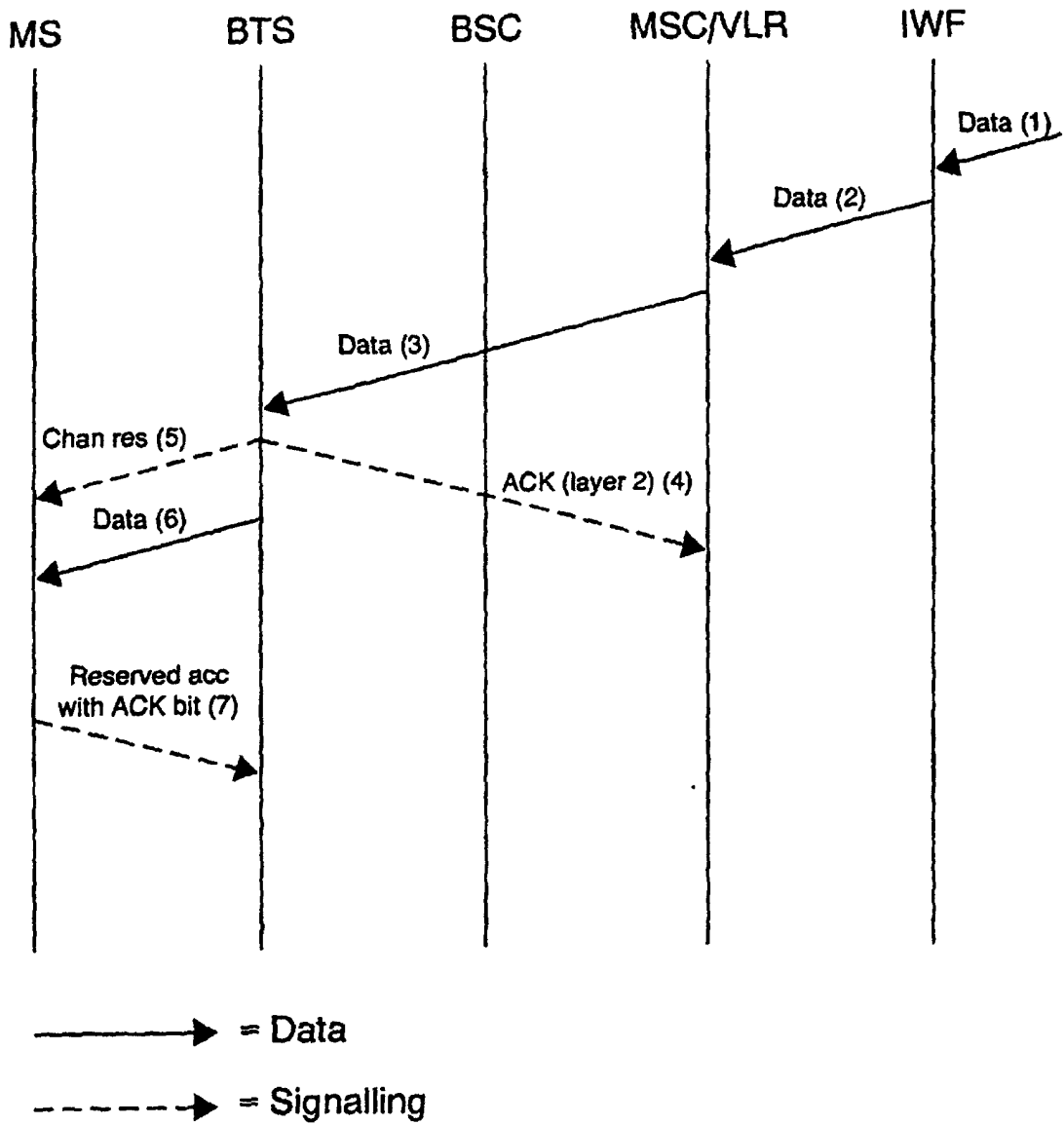

Fig. 11

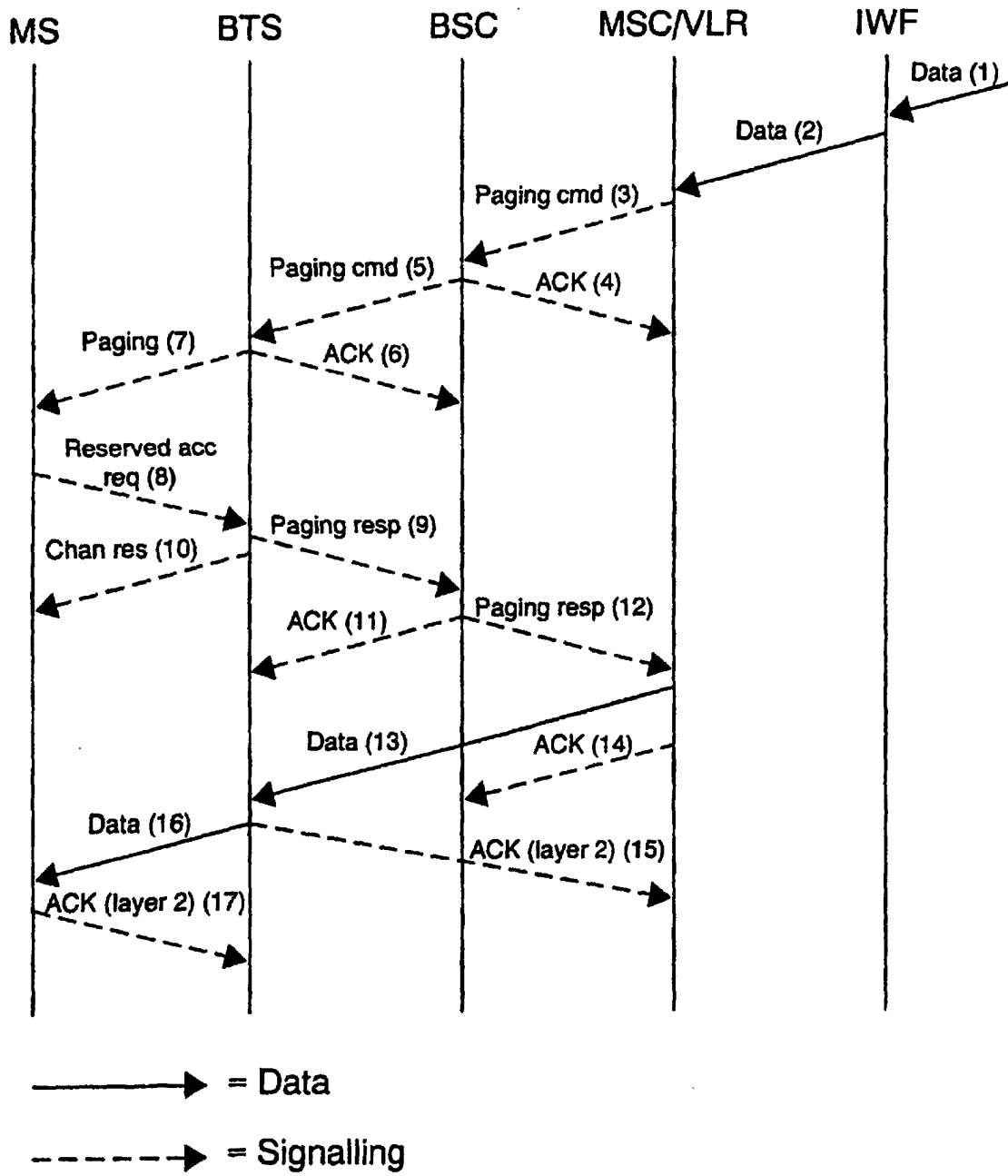

Fig. 12

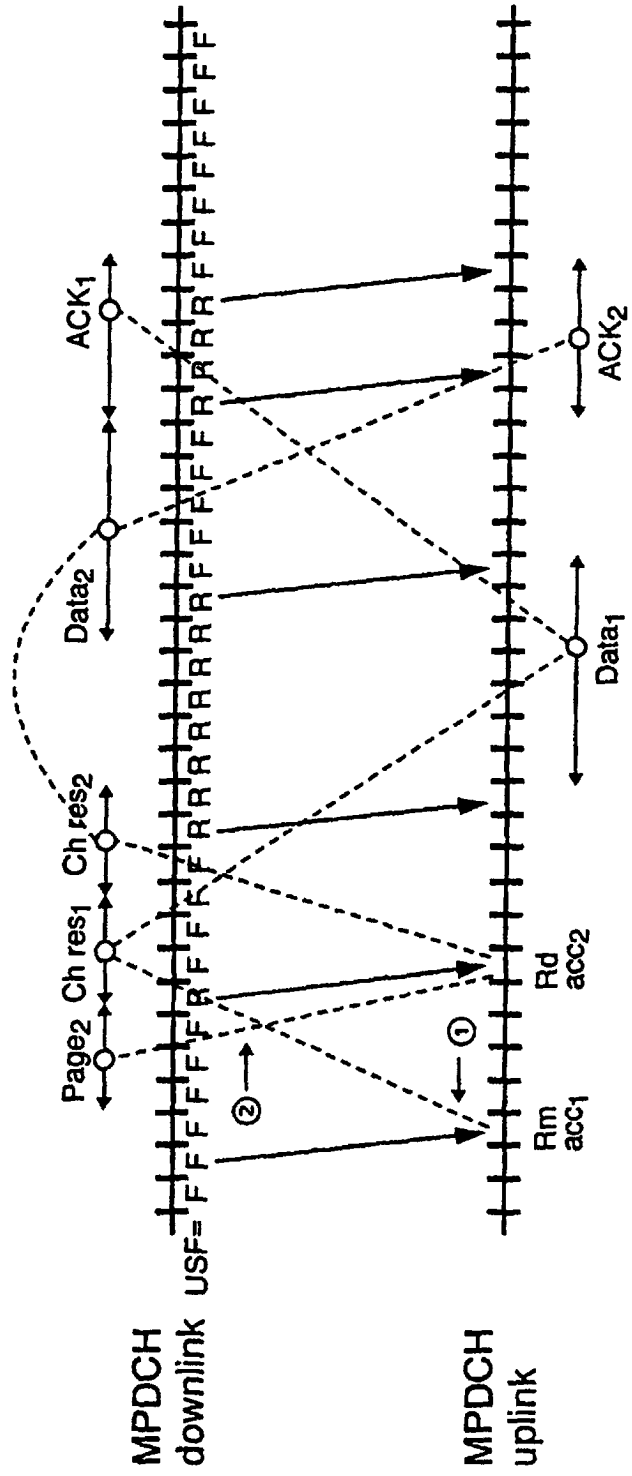

Fig. 13

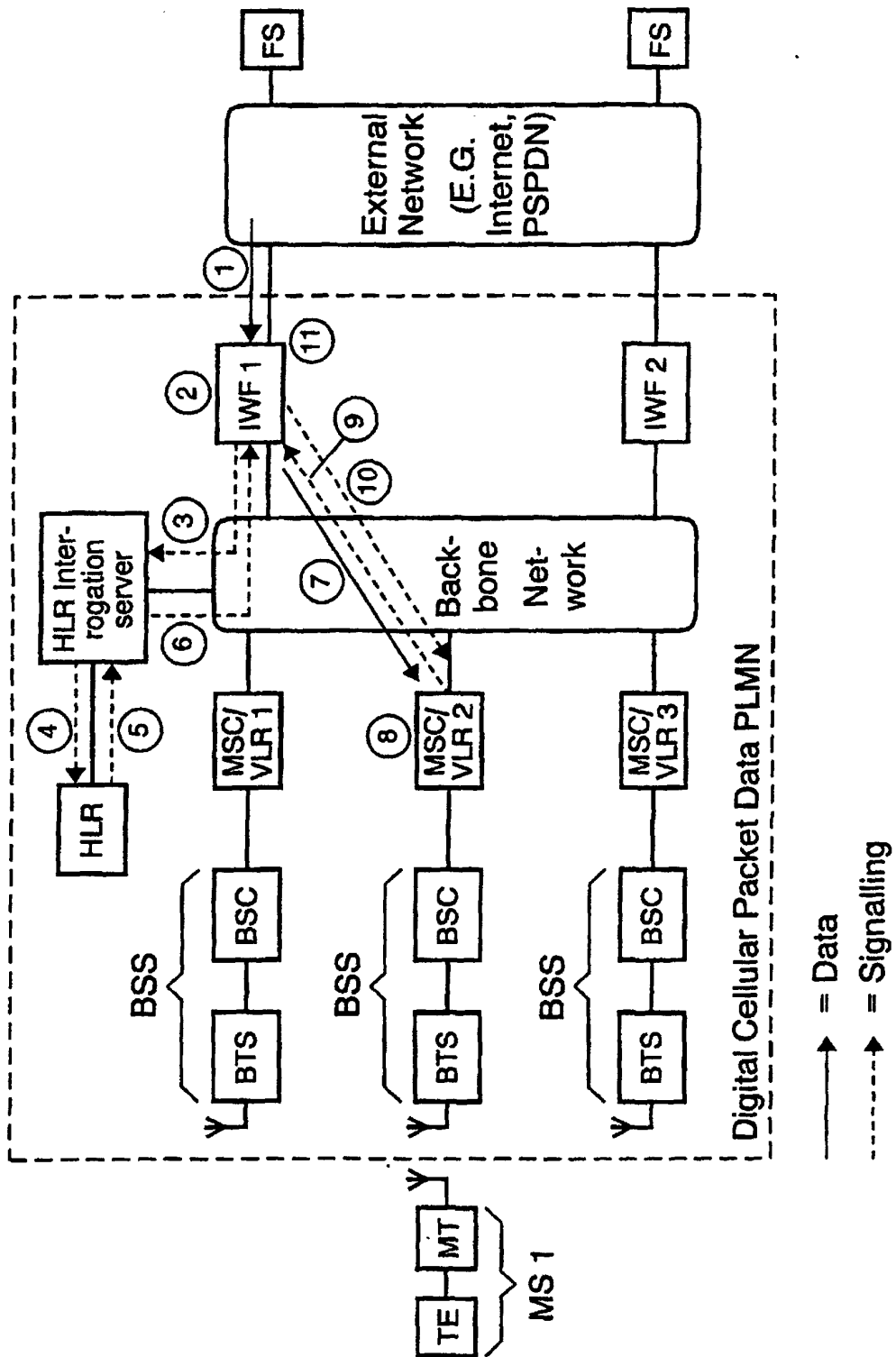

Fig. 14

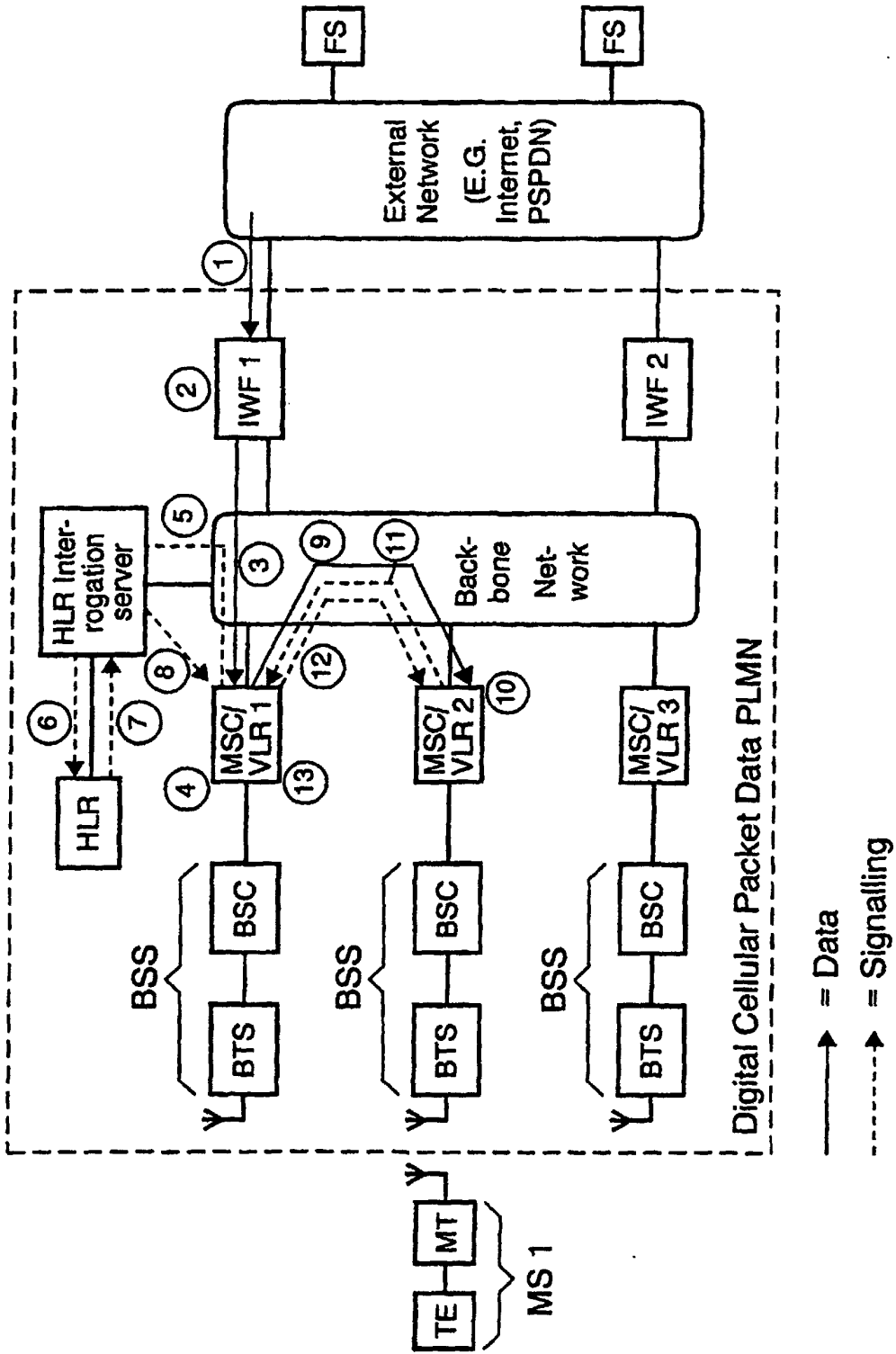

Fig. 15