

No. 674,899.

Patented May 28, 1901.

H. BRADT & C. H. HORSTMAYER.
BROOM.

(Application filed July 13, 1900.)

(No Model.)

2 Sheets—Sheet 1.

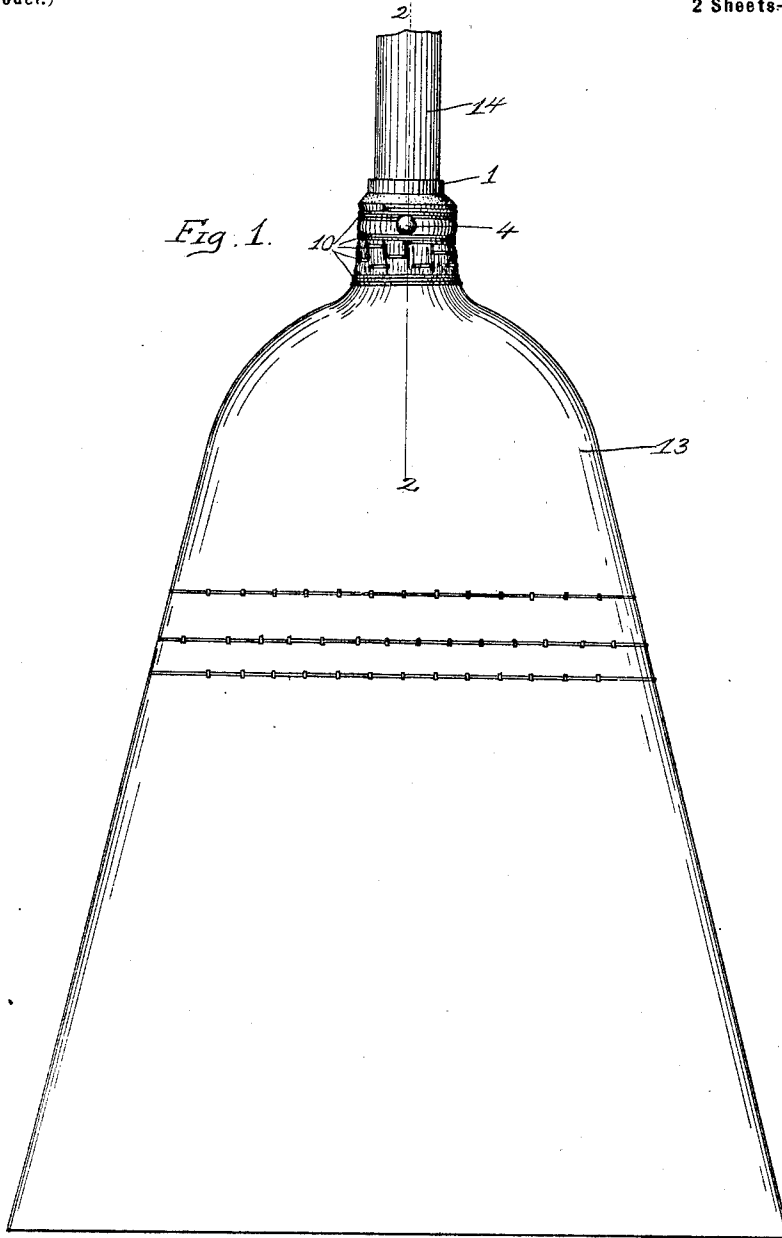

Witnesses:
N. A. Curtis
E. M. O'Reilly

Inventors:
Henry Bradt
and Charles Henry Horstmyer
by Mosher & Curtis
attys

H. BRADT & C. H. HORSTMAYER.

BROOM.

(Application filed July 13, 1900.)

(No Model.)

2 Sheets—Sheet 2.

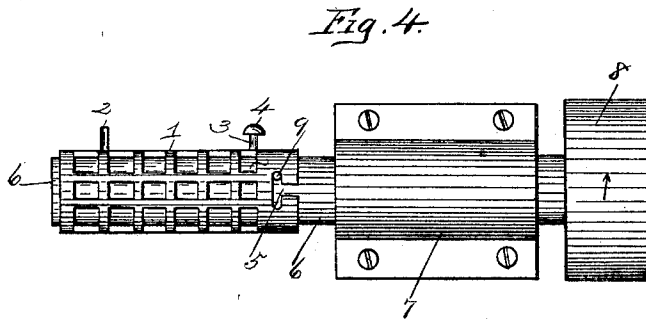
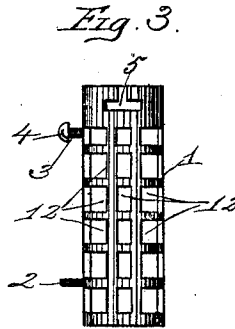
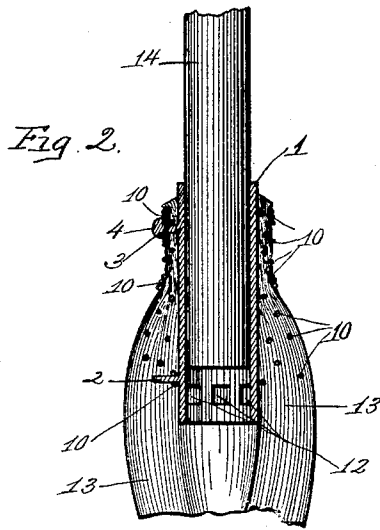

Witnesses:
E. N. Curtis
E. M. O'Reilly

Inventors:
Henry Bradt
and Charles Henry Horstmyer
By Mosher & Curtis
attys.

UNITED STATES PATENT OFFICE.

HENRY BRADT AND CHARLES H. HORSTMAYER, OF SCHENECTADY,
NEW YORK.

BROOM.

SPECIFICATION forming part of Letters Patent No. 674,899, dated May 28, 1901.

Application filed July 13, 1900. Serial No. 23,430. (No model.)

To all whom it may concern:

Be it known that we, HENRY BRADT and CHARLES HENRY HORSTMAYER, citizens of the United States, residing at Schenectady, county of Schenectady, and State of New York, have invented certain new and useful Improvements in Brooms, of which the following is a specification.

The invention relates to such improvements; and it consists of the novel construction and combination of parts hereinafter described and subsequently claimed.

Reference may be had to the accompanying drawings and the reference characters marked thereon, which form a part of this specification.

Similar characters refer to similar parts in the several figures therein.

Figure 1 of the drawings is a plan view of a finished broom having our improved broom-handle socket with a portion of the handle broken away. Fig. 2 is a longitudinal section taken on the broken line 2 2 in Fig. 1. Fig. 3 is a plan view of the socket detached from the broom. Fig. 4 is a plan view of the socket on a rotary mandrel in position for winding.

Our improved socket is especially adapted for use in brooms having detachable handles, whereby longer or shorter handles may be applied to the body of the broom as occasion requires or the handle wholly removed when the brooms are shipped from one place to another.

The object of our invention is to provide a light and strong metal socket which will resist the strain of winding the broom-corn upon it in forming the broom-body, means for fastening the ends of the winding wire, and means for securely holding the socket upon a rotating mandrel during the winding operation.

Our improved socket comprises a tubular metal casting 1, having cast integral therewith a radially-projecting peripheral stud 2 near one end and another similar stud 3 at or near the other end. The latter stud is also provided with a head 4 or similar means for preventing the winding wire coiled around such stud from slipping off. The casting is

also provided at one end with a T-shaped slot 5.

In the manufacture of the broom-body the tubular casting is slipped upon a mandrel 6, which is rotary in a stationary bearing 7, rotary movements being imparted through the pulley 8, driven by a belt. (Not shown.) The mandrel is also provided with a radially-projecting peripheral stud 9, adapted to enter the T-shaped slot and prevent the socket-casting from either turning upon the mandrel or slipping longitudinally of the same. When the mandrel and pulley turn in the direction of the arrow, the stud 9 is forced into that end of the slot shown occupied in Fig. 4. When the mandrel turns in the opposite direction, the stud 9 is forced into the opposite end of the slot. This provides that in whichever direction the parts are relatively turned the socket-casting is locked against longitudinal movement on the mandrel.

To remove the casting from the mandrel, it is only necessary to turn the casting by hand upon the mandrel until the stud 9 is opposite the opening of the slot, when it can be slipped off the mandrel.

After the socket-casting has been placed upon the mandrel, as shown in Fig. 4, one end of the winding wire 10 is secured to the stud 2 and the mandrel and casting slowly rotated, knots or parcels of broom-corn 13, as shown in Fig. 2, or other material adapted to form the bodies of brooms or brushes, being inserted at intervals between the wire and casting, so that the wire winds around the inserted material and binds it fast to the casting to form the body of the broom or brush. After the winding operation is completed the other end of the wire is secured to the stud 3, which is long enough to project out beyond the material wound upon the casting. The other stud 2 is preferably short enough to be concealed by the material wound onto the socket. We are thus able to cheaply produce in a single integral casting a strong, light, and durable socket which will not only resist the binding strain of the winding wire, but will securely hold both ends of the wire, avoiding the necessity of providing separate means for fas-

tening the ends of the wire. We are able also to positively secure the casting to the mandrel during the winding process and to easily attach and detach the casting to and from the mandrel.

5 It will be observed that the peculiar formation of the T-shaped slot permits the winding to be made in either direction—that is, the mandrel and casting may be rotated in either
10 direction.

The socket-barrel may be provided with numerous apertures 12, of such size or form as desired, to lighten the same without impairing its strength.

15 The wire-supporting function of the peripheral studs will be the same whether the casting is secured to the mandrel by means of the T-shaped slot or other means, as a separate clamping device.

20 The socket is adapted to receive a wooden or other suitable handle 14, inserted therein.

In the winding operation portions of the broom material are forced tightly into the peripheral depressions formed by apertures 12, which thus serve to prevent relative displacement of the broom material and socket. The sharp edges of those portions of the socket which immediately surround the apertures, which edges are formed between the periphery
25 and the radially-disposed faces of said portions, facilitate the bending of the corn under the pressure put upon it in binding it with

wire, and the corn thus bent over these edges is thereby held from slipping. The apertures are made large as compared with the intermediate portions of metal and occupy by preference about one-half or more of the periphery of the casting. By this means the broom-corn will be depressed in the openings and occupy at such points lines which cut the socket periphery, and a part of the corn will be below said periphery, and thereby more securely held.

What we claim as new, and desire to secure by Letters Patent, is—

A metal socket for brooms comprising a tubular casting provided in its outer periphery with apertures inclosed by portions of the casting having their edges in planes passing through the longitudinal center of the socket
35 whereby sharp edges are presented to corn bound thereon, said apertures occupying a major part of the periphery of the socket to permit broom-corn to be depressed by binding-wire below the socket periphery, substantially as described.

In testimony whereof we have hereunto set our hands this 27th day of June, 1900.

HENRY BRADT.

CHARLES H. HORSTMAYER.

Witnesses:

FREDRICK ROTHMYER,

ALBERT H. BUTLER.