

J. SACHS.
SAFETY FUSE.
APPLICATION FILED DEC. 10, 1903.

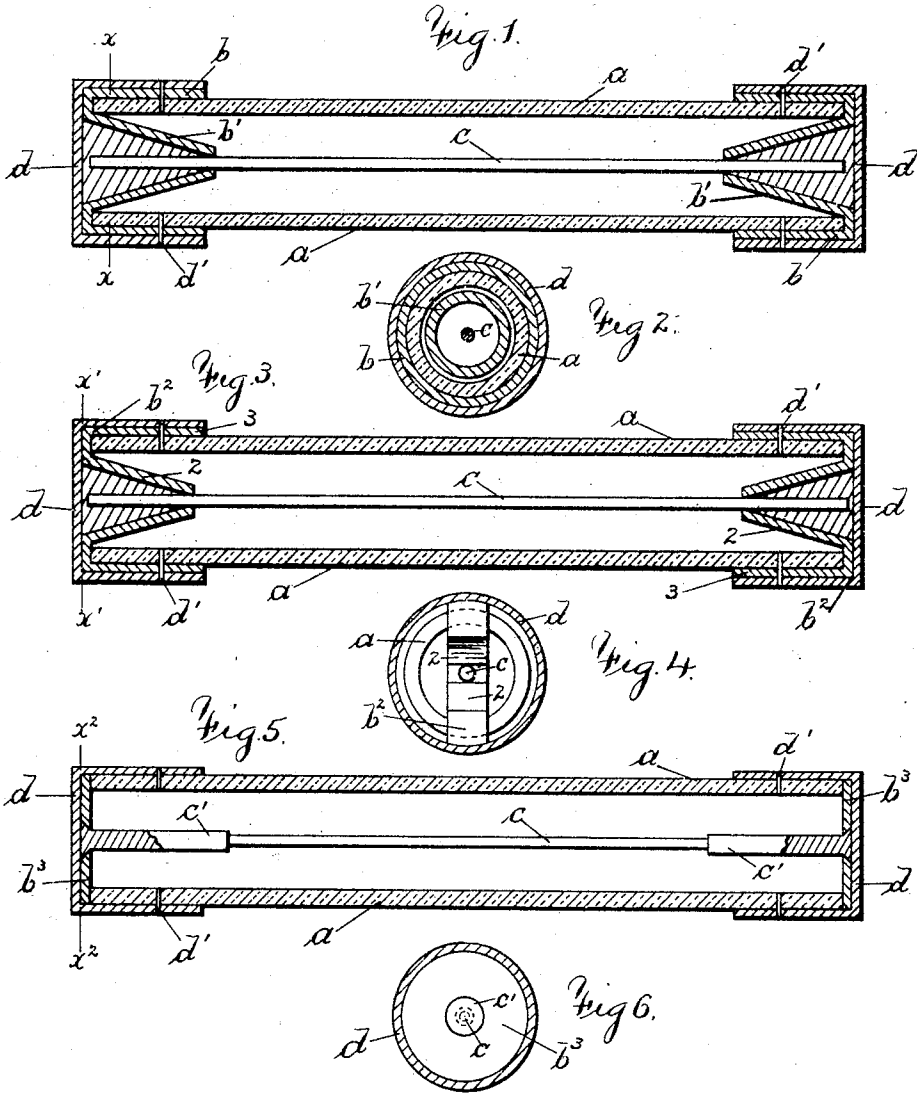

WITNESSES
A. Berrell
Chas. Smith

INVENTOR
Joseph Sachs
 FOR *Harold Berrell*
 ATTY

UNITED STATES PATENT OFFICE.

JOSEPH SACHS, OF HARTFORD, CONNECTICUT, ASSIGNOR TO THE JOHNS-PRATT COMPANY, OF HARTFORD, CONNECTICUT, A CORPORATION OF CONNECTICUT.

SAFETY-FUSE.

No. 797,324.

Specification of Letters Patent.

Patented Aug. 15, 1905.

Application filed December 10, 1903. Serial No. 184,538.

To all whom it may concern:

Be it known that I, JOSEPH SACHS, a citizen of the United States, residing at Hartford, in the county of Hartford and State of Connecticut, have invented an Improvement in Safety-Fuses, of which the following is a specification.

My invention relates to safety-fuses, and in carrying out the same I employ a casing, a fuse-strip, end contact-pieces to which said fuse-strip is electrically and mechanically connected, and end caps contacting electrically with said end pieces and extending over the same and the ends of said casing.

In the drawings, Figure 1 is a central longitudinal section of my improved safety-fuse; and Fig. 2 is a transverse section on line aa , Fig. 1. Fig. 3 is a central longitudinal section illustrating a modification of my improved safety-fuse, and Fig. 4 is a transverse section at line $a'a'$ of Fig. 3. Fig. 5 is a central longitudinal section of a further modification of my invention; and Fig. 6 is a transverse section on line a^2a^2 , Fig. 5.

Referring to Figs. 1 and 2, a represents a casing, preferably tubular and of suitable insulating material. $b\ b$ represent end pieces, made of metal of good conductivity, adapted to fit over the ends of the casing a and cupped up, forming inwardly-projecting walls b' , extending to the inner diameter of the casing a , and c represents the fuse-strip. The cupped portions of the end pieces $b\ b$ are centrally apertured, and the free ends of the fuse-strip c extend through the same and are soldered therein or otherwise suitably connected thereto. $d\ d$ represent end caps adapted to fit over and be forced onto the end pieces $b\ b$, contacting electrically therewith and forming the nominal terminals of the fuse device, and the casing, contact-pieces, and end caps are secured together by suitable pins d' or otherwise.

Referring to Figs. 3 and 4, the end pieces $b^2\ b^2$ may be strips of metal of good conductivity bent to such a shape that there will be a tapering portion 2, in which the fuse-strip c is secured, and having a portion 3 extending exteriorly some distance along the surface of the casing a and over which the end caps $d\ d$ are forced, making electrical contact with said strips $b^2\ b^2$, or, as shown in Figs. 5 and 6, the ends of the fuse-strip c may be con-

nected to suitable terminals c' , secured in disks $b^3\ b^3$, over which the end caps $d\ d$ fit with their inner surfaces contacting electrically with the outer faces of said disks.

I claim as my invention—

1. A safety-fuse comprising a casing, a fuse-strip, end pieces for said casing and to which said fuse-strip is electrically connected, and end caps for the casing fitting over, conforming to the exterior of the end pieces, and in mechanical and electrical contact with the ends of said end pieces.

2. A safety-fuse comprising a casing, a fuse-strip, end pieces fitting over the ends of said casing and having apertured cup-shaped portions extending inwardly within said casing and to which said fuse-strip is electrically connected, and end caps fitting over said end pieces and in contact electrically therewith.

3. A safety-fuse, comprising a casing, a fuse-strip, end pieces fitting over the ends of said casing and having apertured portions extending inwardly within said casing and to which the said fuse-strip is electrically connected, and end caps fitting over the said end pieces in electrical contact therewith.

4. A safety-fuse comprising a casing, a fuse-strip, end pieces fitting over the ends of said casing and having cupped-up apertured portions extending inwardly within said casing and through the apertures of which the respective ends of the fuse pass, solder bodies connecting the ends of the fuse mechanically and electrically to the inner surfaces of the cupped-up inwardly-extending portions, and end caps fitting over the said end pieces and in electrical contact therewith.

5. A safety-fuse comprising a casing, a fuse-strip, end pieces extending exteriorly along the surface of said casing and to which said fuse-strip is electrically connected, and end caps for the casing fitting over, conforming to the exterior of the end pieces, and in electrical and mechanical contact with the ends of said end pieces.

Signed by me this 25th day of November, 1903.

JOSEPH SACHS.

Witnesses:

GEO. T. PINCKNEY,
ARTHUR H. SERRELL.