



- (51) International Patent Classification:
G02B 26/10 (2006.01) *G02F 1/295* (2006.01)
G02F 1/03 (2006.01) *G02B 19/00* (2006.01)
G02F 1/29 (2006.01)
- (21) International Application Number: PCT/US2017/055846
- (22) International Filing Date: 10 October 2017 (10.10.2017)
- (25) Filing Language: English
- (26) Publication Language: English
- (30) Priority Data:
62/409,696 18 October 2016 (18.10.2016) US
15/428,473 09 February 2017 (09.02.2017) US
- (71) Applicant: QUALCOMM INCORPORATED [US/US];
ATTN: International IP Administration, 5775 Morehouse Drive, San Diego, California 92121-1714 (US).
- (72) Inventors: WYRWAS, John; 5775 Morehouse Drive, San Diego, California 92121-1714 (US). HOLMAN, Robert; 5775 Morehouse Drive, San Diego, California 92121-1714 (US). GRUHLKE, Russell; 5775 Morehouse Drive, San Diego, California 92121-1714 (US). ALAM, Khurshid; 5775 Morehouse Drive, San Diego, California 92121-1714 (US). LI, Kebin; 5775 Morehouse Drive, San Diego, California 92121-1714 (US).
- (74) Agent: FU, Zhenhai et al.; Kilpatrick Townsend & Stockton LLP, Mailstop: IP Docketing - 22, 1100 Peachtree Street, N.E., Suite 2800, Atlanta, Georgia 30309 (US).
- (81) Designated States (unless otherwise indicated, for every kind of national protection available): AE, AG, AL, AM,

(54) Title: SELF-ALIGNING TRAVELLING COLLIMATING LENS FOR SWEEPING LASER

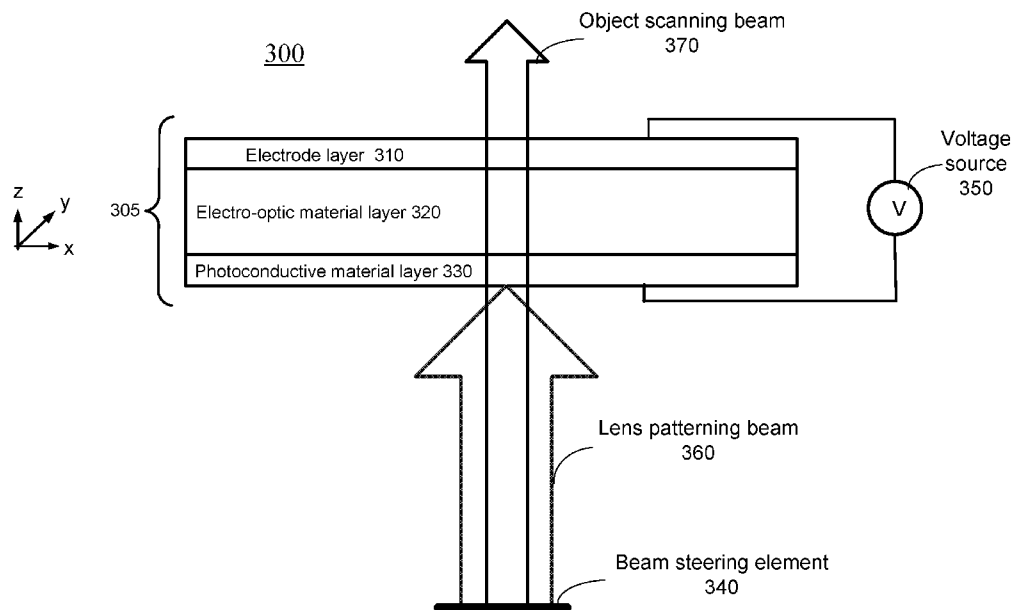

FIG. 3

(57) Abstract: Disclosed herein are techniques for dynamically forming an optical component that automatically aligns with and changes positions with a scanning light beam to modify the wave front of the scanning light beam, such as collimating the scanning light beam. More specifically, a patterning beam that aligns with the scanning light beam may be scanned together with the scanning light beam to form the self-aligning and travelling optical component in an electro-optic material layer that is connected in serial with a photoconductive material layer to a voltage source, where the patterning beam optically modulates the impedance of the photoconductive material layer and therefore an electric field within the electro-optic material layer, the modulated electric field causing localized changes of refractive index in the electro-optic material layer to form the self-aligning and travelling optical component.



AO, AT, AU, AZ, BA, BB, BG, BH, BN, BR, BW, BY, BZ, CA, CH, CL, CN, CO, CR, CU, CZ, DE, DJ, DK, DM, DO, DZ, EC, EE, EG, ES, FI, GB, GD, GE, GH, GM, GT, HN, HR, HU, ID, IL, IN, IR, IS, JO, JP, KE, KG, KH, KN, KP, KR, KW, KZ, LA, LC, LK, LR, LS, LU, LY, MA, MD, ME, MG, MK, MN, MW, MX, MY, MZ, NA, NG, NI, NO, NZ, OM, PA, PE, PG, PH, PL, PT, QA, RO, RS, RU, RW, SA, SC, SD, SE, SG, SK, SL, SM, ST, SV, SY, TH, TJ, TM, TN, TR, TT, TZ, UA, UG, US, UZ, VC, VN, ZA, ZM, ZW.

- (84) Designated States** (*unless otherwise indicated, for every kind of regional protection available*): ARIPO (BW, GH, GM, KE, LR, LS, MW, MZ, NA, RW, SD, SL, ST, SZ, TZ, UG, ZM, ZW), Eurasian (AM, AZ, BY, KG, KZ, RU, TJ, TM), European (AL, AT, BE, BG, CH, CY, CZ, DE, DK, EE, ES, FI, FR, GB, GR, HR, HU, IE, IS, IT, LT, LU, LV, MC, MK, MT, NL, NO, PL, PT, RO, RS, SE, SI, SK, SM, TR), OAPI (BF, BJ, CF, CG, CI, CM, GA, GN, GQ, GW, KM, ML, MR, NE, SN, TD, TG).

Declarations under Rule 4.17:

- *as to applicant's entitlement to apply for and be granted a patent (Rule 4.17(ii))*
- *as to the applicant's entitlement to claim the priority of the earlier application (Rule 4.17(iii))*

Published:

- *with international search report (Art. 21(3))*
- *before the expiration of the time limit for amending the claims and to be republished in the event of receipt of amendments (Rule 48.2(h))*

(88) Date of publication of the international search report:

31 May 2018 (31.05.2018)

INTERNATIONAL SEARCH REPORT

International application No
PCT/US2017/055846

A. CLASSIFICATION OF SUBJECT MATTER
 INV. G02B26/10 G02F1/03 G02F1/29 G02F1/295 G02B19/00
 ADD.
 According to International Patent Classification (IPC) or to both national classification and IPC

B. FIELDS SEARCHED
 Minimum documentation searched (classification system followed by classification symbols)
 G02F G02B
 Documentation searched other than minimum documentation to the extent that such documents are included in the fields searched

Electronic data base consulted during the international search (name of data base and, where practicable, search terms used)
 EPO-Internal, WPI Data

C. DOCUMENTS CONSIDERED TO BE RELEVANT

Category*	Citation of document, with indication, where appropriate, of the relevant passages	Relevant to claim No.
X	GURAL'NIK I P ET AL: "Optically controlled spherical liquid-crystal lens: theory and experiment", QUANTUM ELECTRONICS, TURPION LTD., LONDON, GB, vol. 33, no. 5, 1 May 2003 (2003-05-01), pages 430-434, XP001235631, ISSN: 1063-7818, DOI: 10.1070/QE2003V033N05ABEH002429	1-4,7, 16,17, 23,27,28
Y	the whole document ----- -/--	5,6

Further documents are listed in the continuation of Box C. See patent family annex.

* Special categories of cited documents :

<p>"A" document defining the general state of the art which is not considered to be of particular relevance</p> <p>"E" earlier application or patent but published on or after the international filing date</p> <p>"L" document which may throw doubts on priority claim(s) or which is cited to establish the publication date of another citation or other special reason (as specified)</p> <p>"O" document referring to an oral disclosure, use, exhibition or other means</p> <p>"P" document published prior to the international filing date but later than the priority date claimed</p>	<p>"T" later document published after the international filing date or priority date and not in conflict with the application but cited to understand the principle or theory underlying the invention</p> <p>"X" document of particular relevance; the claimed invention cannot be considered novel or cannot be considered to involve an inventive step when the document is taken alone</p> <p>"Y" document of particular relevance; the claimed invention cannot be considered to involve an inventive step when the document is combined with one or more other such documents, such combination being obvious to a person skilled in the art</p> <p>"&" document member of the same patent family</p>
---	---

Date of the actual completion of the international search 8 January 2018	Date of mailing of the international search report 13/04/2018
--	---

Name and mailing address of the ISA/ European Patent Office, P.B. 5818 Patentlaan 2 NL - 2280 HV Rijswijk Tel. (+31-70) 340-2040, Fax: (+31-70) 340-3016	Authorized officer Baur, Christoph
--	--

INTERNATIONAL SEARCH REPORT

International application No.
PCT/US2017/055846

Box No. II Observations where certain claims were found unsearchable (Continuation of item 2 of first sheet)

This international search report has not been established in respect of certain claims under Article 17(2)(a) for the following reasons:

1. Claims Nos.:
because they relate to subject matter not required to be searched by this Authority, namely:

2. Claims Nos.:
because they relate to parts of the international application that do not comply with the prescribed requirements to such an extent that no meaningful international search can be carried out, specifically:

3. Claims Nos.:
because they are dependent claims and are not drafted in accordance with the second and third sentences of Rule 6.4(a).

Box No. III Observations where unity of invention is lacking (Continuation of item 3 of first sheet)

This International Searching Authority found multiple inventions in this international application, as follows:

see additional sheet

1. As all required additional search fees were timely paid by the applicant, this international search report covers all searchable claims.

2. As all searchable claims could be searched without effort justifying an additional fees, this Authority did not invite payment of additional fees.

3. As only some of the required additional search fees were timely paid by the applicant, this international search report covers only those claims for which fees were paid, specifically claims Nos.:

4. No required additional search fees were timely paid by the applicant. Consequently, this international search report is restricted to the invention first mentioned in the claims; it is covered by claims Nos.:

1-7, 16, 17, 23, 27, 28

Remark on Protest

- The additional search fees were accompanied by the applicant's protest and, where applicable, the payment of a protest fee.
- The additional search fees were accompanied by the applicant's protest but the applicable protest fee was not paid within the time limit specified in the invitation.
- No protest accompanied the payment of additional search fees.

INTERNATIONAL SEARCH REPORT

International application No
PCT/US2017/055846

C(Continuation). DOCUMENTS CONSIDERED TO BE RELEVANT		
Category*	Citation of document, with indication, where appropriate, of the relevant passages	Relevant to claim No.
X	LIN SHIH-HUNG ET AL: "Fresnel Lenses in 90[deg.] Twisted-Nematic Liquid Crystals With Optical and Electrical Controllability", IEEE PHOTONICS TECHNOLOGY LETTERS, IEEE SERVICE CENTER, PISCATAWAY, NJ, US, vol. 28, no. 13, 1 July 2016 (2016-07-01), pages 1462-1464, XP011609770, ISSN: 1041-1135, DOI: 10.1109/LPT.2016.2555699 [retrieved on 2016-05-09]	1-4,16, 17
Y	the whole document -----	5,6
X	CN 103 217 850 A (UNIV SOUTHEAST) 24 July 2013 (2013-07-24) paragraphs [0001] - [0041]; figures 1-3 -----	1-4,7, 16,17, 23,28
Y	US 2011/043717 A1 (UNIV HONG KONG SCIENCE & TECHN [CN]; VALYUKH SERGIY [SE]; CHIGRINOV VL) 24 February 2011 (2011-02-24) paragraph [0041]; figure 2 -----	5,6

INTERNATIONAL SEARCH REPORT

Information on patent family members

International application No

PCT/US2017/055846

Patent document cited in search report	Publication date	Patent family member(s)	Publication date
CN 103217850	A	24-07-2013	NONE

US 2011043717	A1	24-02-2011	US 2011043717 A1 24-02-2011
			WO 2009131925 A2 29-10-2009

FURTHER INFORMATION CONTINUED FROM PCT/ISA/ 210

This International Searching Authority found multiple (groups of) inventions in this international application, as follows:

1. claims: 1-7, 16, 17, 23, 27, 28

the electrode layer, the electro-optic material layer, and the photoconductive material layer each have a curved shape.

2. claims: 8-15, 19, 22, 24-26, 29, 30

The system has a second light source emitting light of a second wavelength.

3. claims: 18, 20, 21

The lens stack is a travelling lens stack in a beam scanning system.
