

(No Model.)

4 Sheets—Sheet 1.

J. BOLTON & J. C. VAN DYKE.
SEWING MACHINE TABLE.

No. 300,684.

Patented June 17, 1884.

fig. 1.

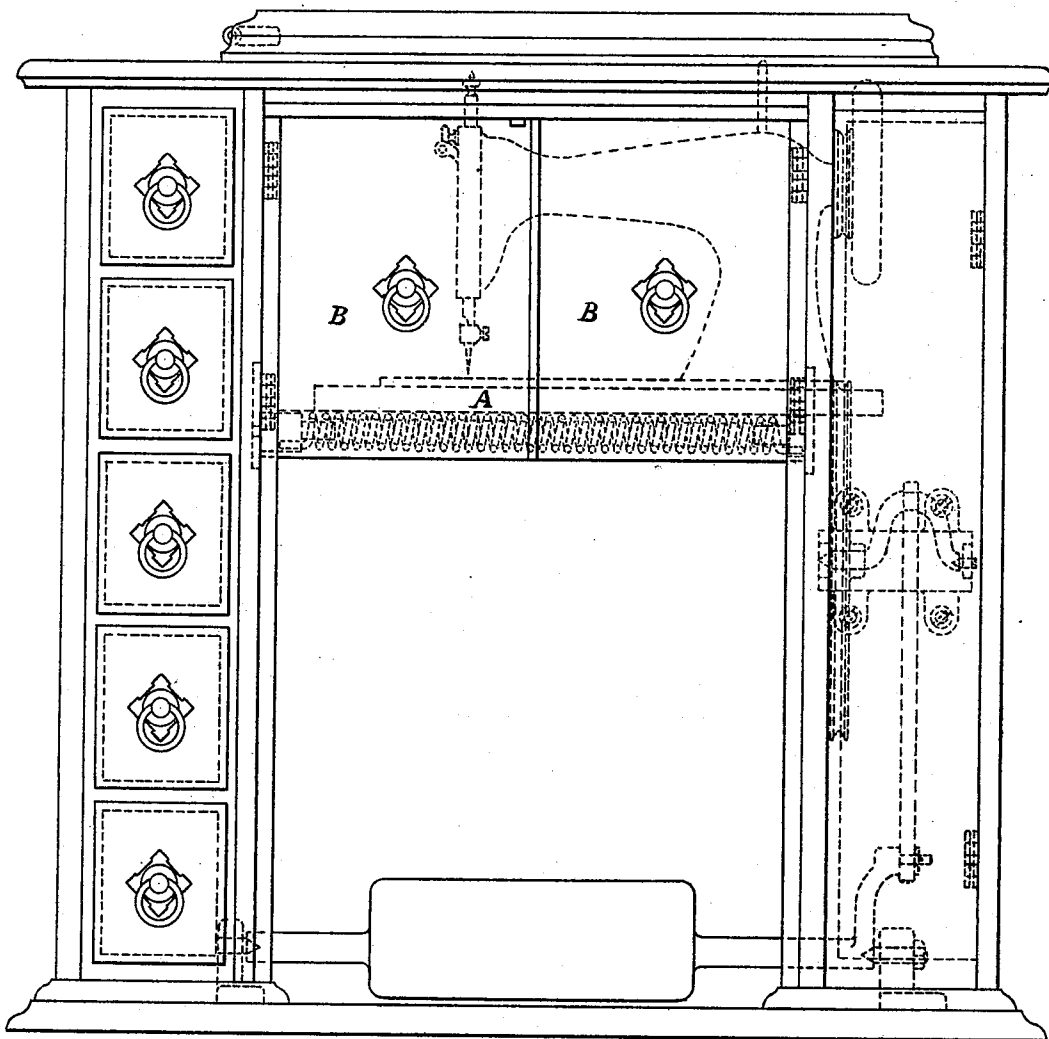

WITNESSES:

Chas. K. King
Wm. J. Smith

INVENTORS

James Bolton
James C. Van Dyke
BY *Sydney A. Bennett*

their ATTORNEY

(No Model.)

4 Sheets—Sheet 2.

J. BOLTON & J. C. VAN DYKE.
SEWING MACHINE TABLE.

No. 300,684.

Patented June 17, 1884.

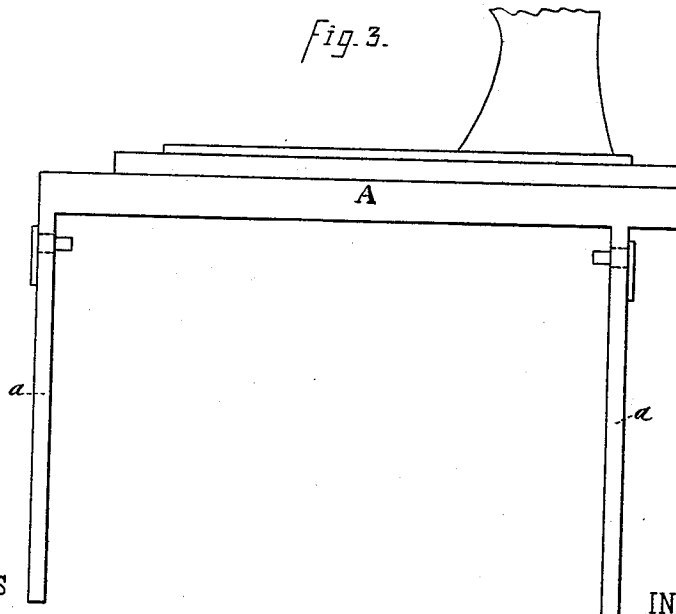
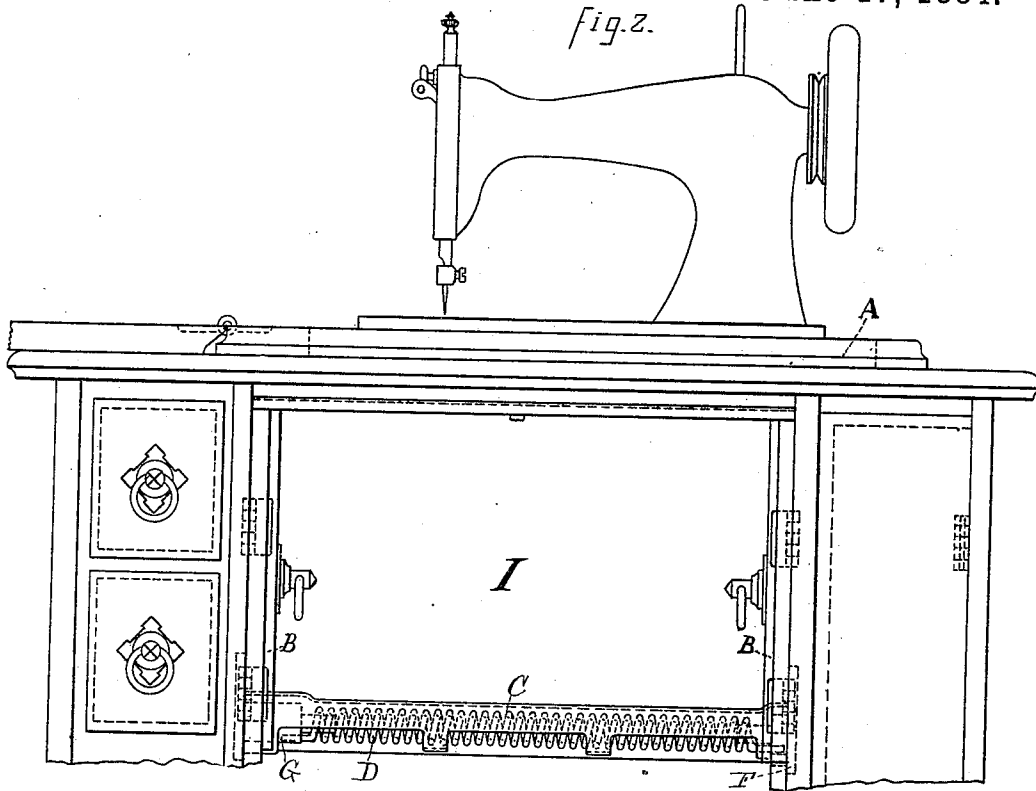

WITNESSES

Chas. E. King
W. J. Scott

INVENTORS

James Bolton
James C. Van Dyke
BY *Sydney A. Bennett*

their ATTORNEY

(No Model.)

4 Sheets—Sheet 3.

J. BOLTON & J. C. VAN DYKE.
SEWING MACHINE TABLE.

No. 300,684.

Patented June 17, 1884.

Fig. 4.
I

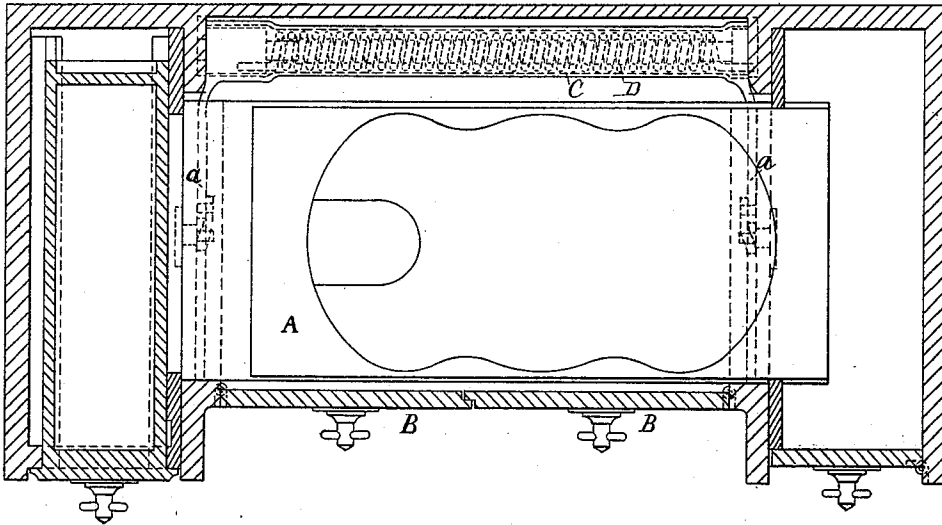
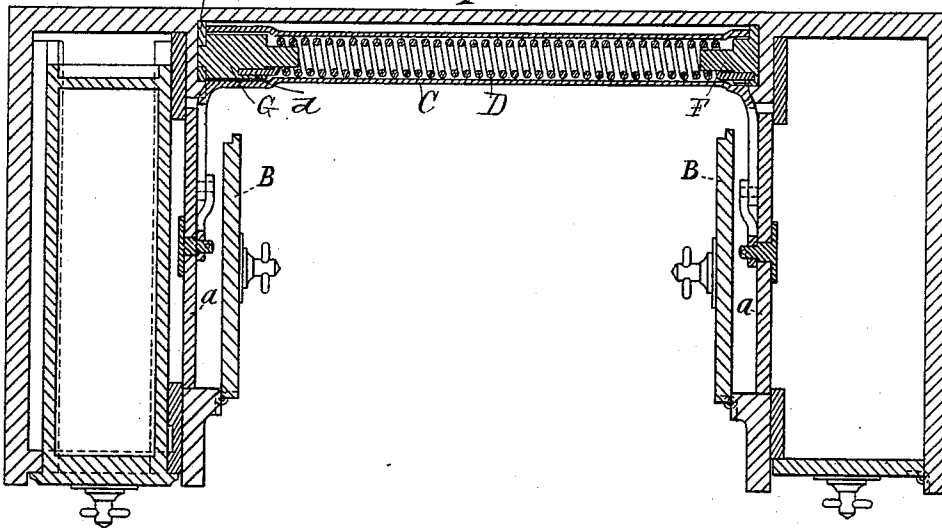

Fig. 5.
I



WITNESSES:

Charles King
Indicoth

INVENTORS

James Bolton
James C. Van Dyke
BY *Sydney A. Bennett*

Their ATTORNEY

J. BOLTON & J. C. VAN DYKE.
SEWING MACHINE TABLE.

No. 300,684.

Patented June 17, 1884.

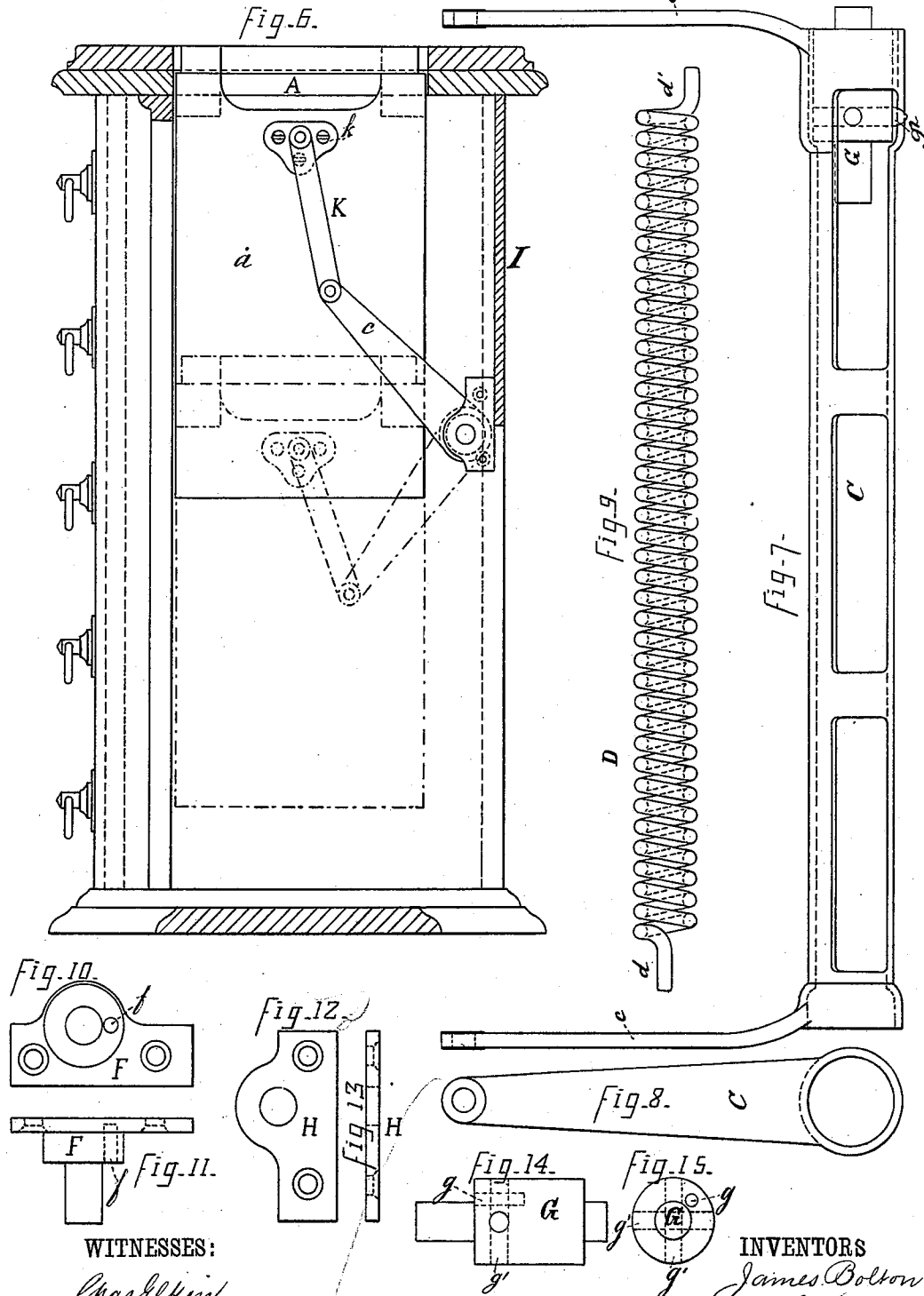

WITNESSES:

Chas. Klein
Ans. Scott

INVENTORS

James Bolton
James C. Van Dyke

BY *Sydney A. Bennett*

their ATTORNEY

UNITED STATES PATENT OFFICE.

JAMES BOLTON, OF CHICAGO, ILLINOIS, AND JAMES C. VAN DYKE, OF ELIZABETH, NEW JERSEY, ASSIGNORS TO THE SINGER MANUFACTURING COMPANY OF NEW JERSEY.

SEWING-MACHINE TABLE.

SPECIFICATION forming part of Letters Patent No. 300,684, dated June 17, 1884.

Application filed February 24, 1883. (No model.)

To all whom it may concern:

Be it known that we, JAMES BOLTON, of the city of Chicago, in the county of Cook and State of Illinois, and JAMES C. VAN DYKE, of the city of Elizabeth, in the county of Union and State of New Jersey, have made an invention of certain new and useful Improvements in Sewing-Machine Tables; and we do hereby declare that the following is a full, clear, and exact description and specification of the same.

Our invention relates to that class of sewing-machine cabinets in which the machine when not in use is caused to descend through the table and is then concealed by suitable devices, and relates especially to the mechanism for raising and lowering such machine, supporting it when raised, and concealing it when lowered.

In the drawings, Figure 1 is a front view of such cabinet closed, the position of the lowered machine being indicated by dotted lines. Fig. 2 shows the upper portion of such cabinet with the machine raised and in position to sew. Fig. 3 illustrates the movable table on which the machine rests. Figs. 4 and 5 are top views in section. Fig. 6 illustrates the manner of attaching the lifting mechanism to the movable table; and Figs. 7 to 15, inclusive, represent details of such lifting mechanism.

The machine is mounted upon a movable platform or table, A, provided with side pieces, *a a*, extending downward at right angles from it and adapted to slide vertically in suitable grooves or guiding-ways in the sides of the case. The front of the case is provided with two doors, B B. (Shown closed in Figs. 1 and 4, and open in Figs. 2 and 5.) We prefer to arrange these doors so that when fully opened, as in Figs. 2 and 5, they will fit within the case, as indicated in Fig. 2. When the machine is raised, these doors, being opened, sustain the movable table A in position, and also leave a large clear space, so that the operator can conveniently use the treadle. When the machine is to be lowered, these doors are closed to conceal it, and when lowered a hinged

leaf is folded over, as shown in Fig. 1, and as the permanent back piece, I, conceals it on the side opposite the doors, the lowered machine is completely concealed.

To secure the convenient raising and lowering of the machine, we use the frame C, which, at one end, is supported by and turns freely on the fixture F, screwed to the case, and at the other end is sustained by the roller G, to which it is secured. The projecting end of this roller rests and turns freely in the hole of the fixture H. In this frame we place a strong coil-spring, D, one end of which, *d*, enters the whole *f* in the fixture F, (and is consequently fixed to the case,) while its other end, *d'*, enters the hole *g* in the roller G, the latter being fixed to the frame C by one or more pins, *g'*, passing through holes *g'* in said roller. This frame C is provided with arms *c c*, and to each of these arms is pivoted a link, K, (one end of which is shown in Fig. 6,) the other ends of which links are respectively pivoted, as shown, to the sides *a a* of the movable table A. When the machine on said movable table is pressed down, the arms *c c* will be depressed, the frame C will turn on its supports, and, as one end, *d'*, of the coil-spring is attached to said frame and the other end, *d*, is attached to the case, the frame, as it turns, will coil said spring more closely. As the machine, however, approaches the point where it should rest by the depression of the points where said arms *c c* are pivoted to said links, the direction in which the power of the spring is exerted upon the movable table is changed so as to compensate for the increase of power; and in practice we find we can so nearly balance the reaction of the spring against the weight of the machine and table that a light touch will suffice to raise the machine.

We claim as our invention—

1. The combination, with a sewing-machine cabinet having an opening in its top and guiding-ways below the said top, of a vertically-movable platform or table located within said ways, and doors hinged to the sides of the cabinet by vertical pivots, and thereby

adapted to sustain said platform or table when raised and conceal it when lowered, substantially as and for the purpose set forth.

2. The combination, with the upright sides, 5 perforated top, and vertically-movable platform, of the oscillating frame with projecting arms, the links pivoted to such arms and also to the said movable platform, and the coil-spring having one end attached to said oscillating frame and the other secured outside of

said frame, substantially as and for the purposes described.

JAMES BOLTON.
JAMES C. VAN DYKE.

Witnesses:

GEO. F. BROWN,
N. S. ELDERKIN,
L. B. MILLER,
A. D. HARTWELL.