

(19) World Intellectual Property  
Organization  
International Bureau



(43) International Publication Date  
4 March 2004 (04.03.2004)

PCT

(10) International Publication Number  
**WO 2004/018836 A1**

(51) International Patent Classification<sup>7</sup>: **E21B 43/10**

(21) International Application Number:  
PCT/US2003/023913

(22) International Filing Date: 31 July 2003 (31.07.2003)

(25) Filing Language: English

(26) Publication Language: English

(30) Priority Data:  
10/226,941 23 August 2002 (23.08.2002) US

(71) Applicant: **BAKER HUGHES INCORPORATED**  
[US/US]; 3900 Essex Lane, Suite 1200, Houston, TX  
77027 (US).

(72) Inventor: **RICHARD, Bennett, M.**; 4542 Windy Hollow,  
Kingwood, TX 77345 (US).

(74) Agent: **CARSON, Matt, W.**; Baker Oil Tools, 9100 Em-  
mott Road, Houston, TX 77040 (US).

(81) Designated States (*national*): AE, AG, AL, AM, AT, AU, AZ, BA, BB, BG, BR, BY, BZ, CA, CH, CN, CO, CR, CU, CZ, DE, DK, DM, DZ, EC, EE, ES, FI, GB, GD, GE, GH, GM, HR, HU, ID, IL, IN, IS, JP, KE, KG, KP, KR, KZ, LC, LK, LR, LS, LT, LU, LV, MA, MD, MG, MK, MN, MW, MX, MZ, NI, NO, NZ, OM, PG, PH, PL, PT, RO, RU, SC, SD, SE, SG, SK, SL, SY, TJ, TM, TN, TR, TT, TZ, UA, UG, UZ, VC, VN, YU, ZA, ZM, ZW.

(84) Designated States (*regional*): ARIPO patent (GH, GM, KE, LS, MW, MZ, SD, SL, SZ, TZ, UG, ZM, ZW), Eurasian patent (AM, AZ, BY, KG, KZ, MD, RU, TJ, TM), European patent (AT, BE, BG, CH, CY, CZ, DE, DK, EE, ES, FI, FR, GB, GR, HU, IE, IT, LU, MC, NL, PT, RO, SE, SI, SK, TR), OAPI patent (BF, BJ, CF, CG, CI, CM, GA, GN, GQ, GW, ML, MR, NE, SN, TD, TG).

**Published:**

- with international search report
- before the expiration of the time limit for amending the claims and to be republished in the event of receipt of amendments

For two-letter codes and other abbreviations, refer to the "Guidance Notes on Codes and Abbreviations" appearing at the beginning of each regular issue of the PCT Gazette.

(54) Title: SELF-CONFORMING WELL SCREEN

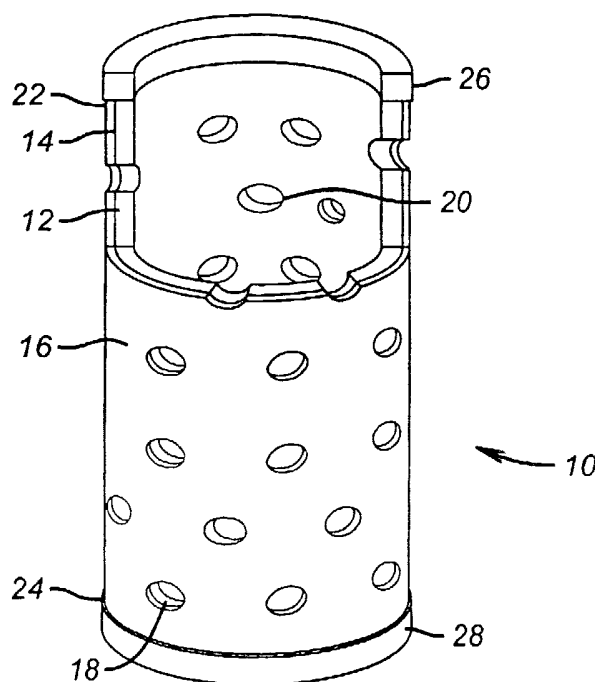

(57) Abstract: A screen that conforms to the borehole shape after expansion is disclosed. The screen comprises a compliant outer layer that takes the borehole shape on expansion. The outer layer is formed having holes to permit production flow. The material that is selected preferably swells with prolonged contact to well fluids to further close off annular gaps after expansion. In an alternative embodiment, the screen is not expanded and the swelling of the material alone closes off annular gaps. The outer sleeve is placed over the screen and the screen is placed on a base pipe and initially expanded from within the base pipe to secure the components of the screen assembly for running downhole, while minimizing or eliminating any welding among the layers. A variety of expansion tools can be used to expand the screen or screens downhole.

WO 2004/018836 A1

**APPLICATION FOR PATENT**

Title: SELF-CONFORMING WELL SCREEN

Inventor: Bennett M. Richard

**FIELD OF THE INVENTION**

[ 0001] The field of this invention is downhole screens and more particularly those that can be expanded in open hole to close off an irregularly shaped borehole.

**BACKGROUND OF THE INVENTION**

[ 0002] In the past sand control methods have been dominated by gravel packing outside of downhole screens. The idea was to fill the annular space outside the screen with sand to prevent the production of undesirable solids from the formation. More recently, with the advent of tubular expansion technology, it was thought that the need for gravel packing could be eliminated if a screen or screens could be expanded in place to eliminate the surrounding annular space that had heretofore been packed with sand. Problems arose with the screen expansion technique as a replacement for gravel packing because of wellbore shape irregularities. A fixed swage would expand a screen a fixed amount. The problems were that a washout in the wellbore would still leave a large annular space outside the screen. Conversely, a tight spot in the wellbore could create the risk of sticking the fixed swage.

[ 0003] One improvement of the fixed swage technique was to use various forms of flexible swages. In theory these flexible swages were compliant so that in a tight spot they would flex inwardly and reduce the chance of sticking the swage. On the other hand, if there was a void area, the same problem persisted in that the flexible swage had a finite outer dimension to which it would expand the screen. Therefore, the use of flexible swages still left the problem of annular gaps outside the

screen with a resulting undesired production of solids when the well was put on production from that zone.

[ 0004] Prior designs of screens have used pre-compressed mat held by a metal sheath that is then subjected to a chemical attack when placed in the desired location downhole. The mat is then allowed to expand from its pre-compressed state. The screen is not expanded. This design is described in U.S. Patents 2,981,332 and 2,981,333. U.S. Patent 5,667,011 shows a fixed swage expanding a slotted liner downhole. U.S. Patents 5,901,789 and 6,012,522 show well screens being expanded. U.S. 6,253,850 shows a technique of inserting one solid liner in another already expanded slotted liner to blank it off and the used of rubber or epoxies to seal between the liners. U.S. Patent 6,263,966 shows a screen with longitudinal pleats being expanded downhole. U.S. Patent 5,833,001 shows rubber cured in place to make a patch after being expanded with an inflatable. Finally, U.S. Patent 4,262,744 is of general interest as a technique for making screens using molds.

[ 0005] The apparatus and method of the present invention addresses this issue by providing a screen assembly with an outer layer that can conform to the borehole shape upon expansion. In the preferred embodiment the material is selected that will swell in contact with wellbore fluids to further promote filling the void areas in the borehole after expansion. In an alternative design, screen expansion is not required and the outermost layer swells to conform to the borehole shape from contact with well fluids or other fluids introduced into the wellbore. The screen section is fabricated in a manner that reduces or eliminates welds. Welds are placed under severe loading in an expansion process, so minimizing or eliminating welds provides for more reliable screen operation after expansion. These and other advantages of the present invention will become more apparent to one skilled in the art from a review of the description of the preferred embodiment and the claims that appear below.

### **SUMMARY OF THE INVENTION**

[ 0006] A screen that conforms to the borehole shape after expansion is disclosed. The screen comprises a compliant outer layer that takes the borehole shape on expansion. The outer layer is formed having holes to permit production flow. The material that is selected preferably swells with prolonged contact to well fluids to further close off annular gaps after expansion. In an alternative embodiment, the screen is not expanded and the swelling of the material alone closes off annular gaps. The outer sleeve is placed over the screen and the screen is placed on a base pipe and initially expanded from within the base pipe to secure the components of the screen assembly for running downhole, while minimizing or eliminating any welding among the layers. A variety of expansion tools can be used to expand the screen or screens downhole.

### **BRIEF DESCRIPTION OF THE DRAWINGS**

[ 0007] Figure 1 is a cutaway view of the screen shown in elevation; and

[ 0008] Figure 2 is a section view of an assembly of screens, one of which is shown in Figure 1, in the expanded position downhole.

### **DETAILED DESCRIPTION OF THE PREFERRED EMBODIMENT**

[ 0009] Figure 1 illustrates a portion of a section of screen **10**. It has a base pipe **12** over which is the screen **14** and over which is outer conforming layer **16**. Layer **16** has a plurality of holes **18**. The base pipe **12** also has holes **20**. The actual filter material or screen **14** can be a mesh or a weave or other known filtration products. The conforming layer **16** is preferably soft so that it will flow upon expansion of the screen **10**. The preferred material is one that will swell when exposed to well fluids for an extended period of time. Three examples are nitrile, natural rubber, and AFLAS. In an alternative embodiment, the conforming layer **16** swells sufficiently after being run into the wellbore,

to contact the wellbore, without expansion of the screen **10**. Shown schematically at the ends **22** and **24** of screen **10** are stop rings **26** and **28**. These stop rings will contain the conforming layer **16** upon expansion of screen **10** against running longitudinally in an annular space outside screen **10** after it is expanded. Their use is optional.

[**0010**] The manner of assembly of the screen **10** is another aspect of the invention. The conforming layer **16** can have an internal diameter that allows it to be slipped over the screen material **14**. The assembly of the screen material **14** and the conforming layer **16** are slipped over the base pipe **12**. Thereafter, a known expansion tool is applied internally to base pipe **12** to slightly expand it. As a result, the screen material **14** and the conforming layer **16** are both secured to the base pipe **12** without need for welding. This is advantageous because when the screen **10** is run in the wellbore and expanded, the expansion process can put large stresses on welds that may cause screen failure. An alternative way to assemble screen **10** is to attach the screen material **14** to the base pipe **12** in the manner just described and then to cure the conforming layer **16** right onto the screen material **14**. As another option a protective outer jacket (not shown) can be applied over screen material **14** and the conforming layer **16** mounted above. The joining process even with the optional perforated protective jacket (not shown) is the outward expansion from within the base pipe **12**, as previously described.

[**0011**] The holes **18** can have a variety of shapes. Their function is to allow formation fluids to pass after expansion. They can be round holes or slots or other shapes or combinations of shapes. The conforming layer **16** can be made of a polymeric material and is preferably one that swells on sustained exposure to well fluids to better conform to irregular shapes in the borehole **30**, as shown in Figure 2. Figure 2 also shows the outer protective jacket **32** that goes over screen material **14** and

below conforming layer 16 to protect the screen material 14 when run into the borehole 30. Jacket 32 is a known product that has punched openings 33 and can optionally be used if the conforming layer 16 is used. The reason it is optional is that the conforming layer 16 to some degree provides the desired protection during run in. Additionally, without jacket 32, the conforming layer 16 can be made thicker to better fill in void volume 34 in the annular space around a screen 10 after expansion. The thickness of the conforming layer 16 is limited by the borehole and the outer diameter of the components mounted inside of it. It is preferred that the conforming layer 16 be squeezed firmly as that promotes its movement to fill voids in the surrounding annular space.

[ 0012] Those skilled in the art will appreciate that the present invention allows for fabrication of an expandable screen with welds between layers eliminated. The use of the conforming material 16 allows a variety of expansion techniques to be used and an improvement of the ability to eliminate void spaces outside the expanded screen caused by borehole irregularities. Alternatively, the conforming material 16 can swell sufficiently without downhole expansion of the screen 10 to allow for the elimination of the need to gravel pack. If the material swells due to exposure to fluids downhole, its use as the conforming layer 16 is desired. A protective jacket 32 under the conforming layer 16 may be used to protect the screen material 14 during run in.

[ 0013] The foregoing disclosure and description of the invention are illustrative and explanatory thereof, and various changes in the size, shape and materials, as well as in the details of the illustrated construction, may be made without departing from the spirit of the invention.

I claim:

1. A well completion method, comprising:  
covering at least one well screen with a conforming material;  
running said screen to a desired location in the wellbore;  
expanding the screen and conforming material;  
forcing the conforming material to take the shape of the wellbore by said expanding.
2. The method of claim 1, comprising:  
forcing said conforming material to flow along the wellbore by said expanding of said screen.
3. The method of claim 1, comprising:  
selecting a material for said conforming material that swells after said expanding.
4. The method of claim 1, comprising:  
selecting a material for said conforming material from among a polymeric material, such as nitrile, natural rubber and AFLAS.
5. The method of claim 1, comprising:  
providing at least one opening in said conforming material.
6. The method of claim 5, comprising:  
using a plurality of openings such as holes, slots, diamonds, squares, rectangles or other shapes as said at least one opening.
7. The method of claim 1, comprising:  
containing said conforming material with at least one stop ring.

8. The method of claim 1, comprising:  
securing said conforming material to said well screen by outward expansion of said screen prior to said running said screen into the wellbore.
9. The method of claim 1, comprising:  
securing said conforming material to said well screen by curing said conforming material to said screen.
10. The method of claim 1, comprising:  
providing a protective jacket between said screen and said conforming material.
11. The method of claim 10, comprising:  
securing said protective jacket to said screen by outward expansion of said screen prior to said running said screen into the wellbore.
12. The method of claim 1, comprising:  
providing a perforated base pipe covered by a screen material as said screen;  
attaching said screen material to said perforated base pipe by expanding said base pipe prior to said running said screen into the wellbore.
13. The method of claim 12, comprising:  
joining said screen material to said base pipe without welding.
14. The method of claim 10, comprising:  
joining said protective jacket to said screen without welding.
15. A method of manufacturing a screen to be expanded downhole, comprising:  
putting a sleeve of screen material over a perforated base pipe;

- expanding said base pipe;  
securing the screen material to said base pipe as a result of said expanding.
16. The method of claim 15, comprising:  
joining the screen material to the base pipe without welding.
17. The method of claim 15, comprising:  
placing a sleeve of conforming material over said screen material prior to said expanding;  
securing said conforming material to said screen material as a result of said expanding.
18. The method of claim 15, comprising:  
placing a sleeve of conforming material over said screen material prior to said expanding;  
securing said conforming material to said screen material as a result of bonding.
19. The method of claim 15, comprising:  
providing a protective jacket between said screen material and said conforming material;  
securing said protective jacket to said screen material as a result of said expanding.
20. The method of claim 17, comprising:  
providing at least one travel stop for said conforming material on said base pipe.
21. The method of claim 17, comprising:  
selecting a material for said conforming material that swells when exposed to fluids  
downhole for a predetermined time.
22. A well completion method, comprising:  
covering at least one well screen with an unrestrained conforming material;  
running said screen to a desired location in the wellbore;  
allowing said unrestrained conforming material to swell from exposure to fluids downhole.

23. The method of claim 22, comprising:  
allowing said conforming material to swell to the shape of the surrounding wellbore.
24. The method of claim 22, comprising:  
securing said conforming material to said well screen by outward expansion of said screen prior to said running said screen into the wellbore.
25. The method of claim 22, comprising:  
securing said conforming material to said screen material as a result of bonding.
26. The method of claim 23, comprising:  
expanding the screen and conforming material;  
forcing said conforming material to flow along the wellbore by said expanding of said screen.

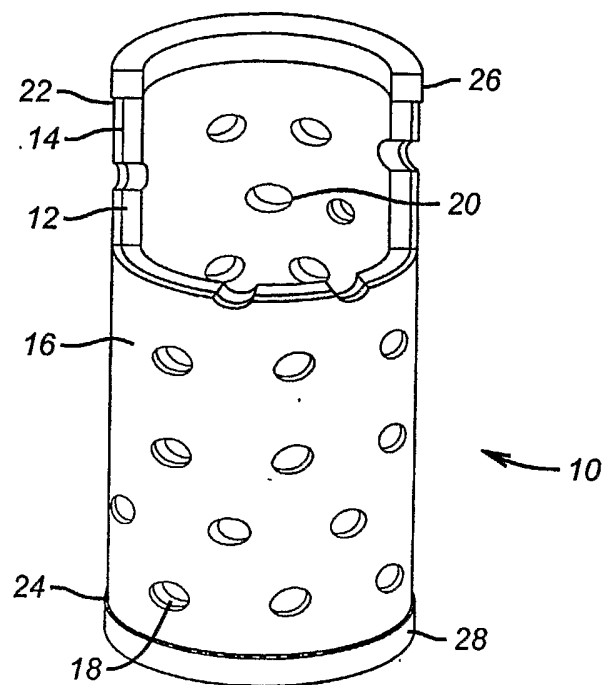

**FIG. 1**

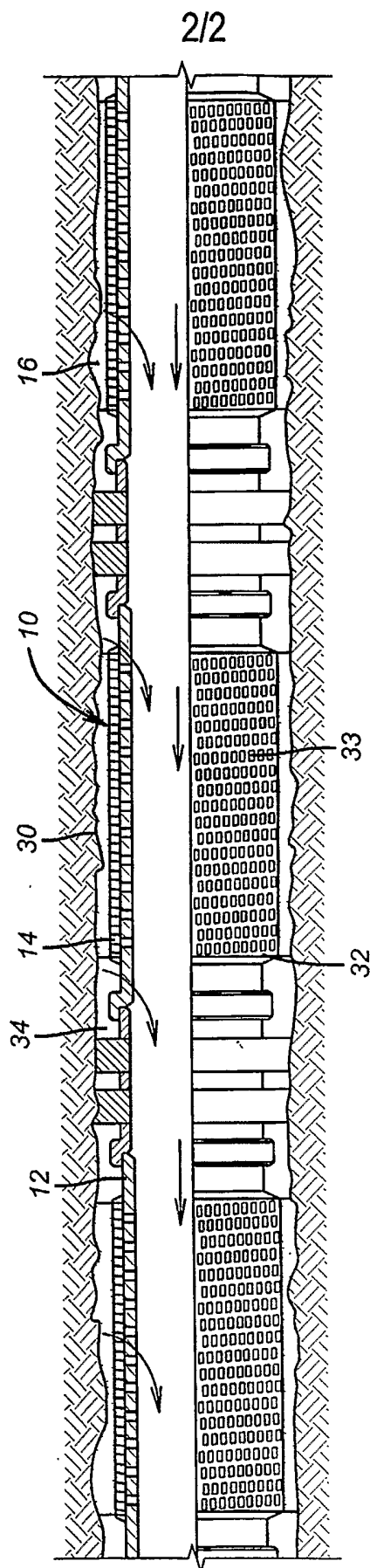

**FIG. 2**

# INTERNATIONAL SEARCH REPORT

International Application No

PCT/US 03/23913

**A. CLASSIFICATION OF SUBJECT MATTER**

IPC 7 E21B43/10

According to International Patent Classification (IPC) or to both national classification and IPC

**B. FIELDS SEARCHED**

Minimum documentation searched (classification system followed by classification symbols)

IPC 7 E21B

Documentation searched other than minimum documentation to the extent that such documents are included in the fields searched

Electronic data base consulted during the international search (name of data base and, where practical, search terms used)

EPO-Internal

**C. DOCUMENTS CONSIDERED TO BE RELEVANT**

Category °	Citation of document, with indication, where appropriate, of the relevant passages	Relevant to claim No.
X	US 2002/084070 A1 (ANGELLE SIMON ET AL) 4 July 2002 (2002-07-04) page 1, paragraph 3 -page 2, paragraph 19	1,2,5,6, 8-19
Y	page 2, paragraph 20 -page 3, paragraph 21 ---	20-22
X	GB 2 347 446 A (PETROLINE WELLSYSTEMS LTD ;WEATHERFORD LAMB (US)) 6 September 2000 (2000-09-06) the whole document ---	1,4-7, 15-17
P,Y	US 2003/075323 A1 (VERCAEMER CLAUDE ET AL) 24 April 2003 (2003-04-24) page 3, paragraph 41 ---	20-22
P,Y	US 2003/136562 A1 (PAHMIYER ROBERT C ET AL) 24 July 2003 (2003-07-24) page 4, paragraph 58 ---	20-22
	-/--	

Further documents are listed in the continuation of box C.

Patent family members are listed in annex.

° Special categories of cited documents :

- \*A\* document defining the general state of the art which is not considered to be of particular relevance
- \*E\* earlier document but published on or after the international filing date
- \*L\* document which may throw doubts on priority claim(s) or which is cited to establish the publication date of another citation or other special reason (as specified)
- \*O\* document referring to an oral disclosure, use, exhibition or other means
- \*P\* document published prior to the international filing date but later than the priority date claimed

- \*T\* later document published after the international filing date or priority date and not in conflict with the application but cited to understand the principle or theory underlying the invention
- \*X\* document of particular relevance; the claimed invention cannot be considered novel or cannot be considered to involve an inventive step when the document is taken alone
- \*Y\* document of particular relevance; the claimed invention cannot be considered to involve an inventive step when the document is combined with one or more other such documents, such combination being obvious to a person skilled in the art.
- \*&\* document member of the same patent family

Date of the actual completion of the international search

21 January 2004

Date of mailing of the international search report

28/01/2004

Name and mailing address of the ISA

European Patent Office, P.B. 5818 Patentlaan 2  
NL - 2280 HV Rijswijk  
Tel. (+31-70) 340-2040. Tx. 31 651 epo nl,  
Fax: (+31-70) 340-3016

Authorized officer

Morrish, S

## INTERNATIONAL SEARCH REPORT

International Application No

PCT/US 03/23913

C.(Continuation) DOCUMENTS CONSIDERED TO BE RELEVANT		
Category °	Citation of document, with indication, where appropriate, of the relevant passages	Relevant to claim No.
A	US 6 431 282 B1 (BOSMA MARTIN GERARDS RENE ET AL) 13 August 2002 (2002-08-13) the whole document -----	1, 15, 22
A	US 6 250 385 B1 (MONTARON BERNARD A) 26 June 2001 (2001-06-26) column 6, line 44 -column 6, line 57; figure 7 -----	1, 15, 22
A	US 3 477 506 A (MALONE BILLY C) 11 November 1969 (1969-11-11) page 3, line 33 -page 3, line 50 -----	1, 15, 22

# INTERNATIONAL SEARCH REPORT

Information on patent family members

Internat~~l~~ Application No

PCT/US 03/23913

Patent document cited in search report	Publication date	Patent family member(s)	Publication date	
US 2002084070	A1	04-07-2002	AU 8709201 A	26-03-2002
			CA 2391052 A1	21-03-2002
			GB 2374098 A	09-10-2002
			NO 20022188 A	04-07-2002
			WO 0223009 A2	21-03-2002
			US 2002070031 A1	13-06-2002
GB 2347446	A	06-09-2000	AU 8348898 A	08-02-1999
			US 6457533 B1	01-10-2002
			WO 9902818 A1	21-01-1999
US 2003075323	A1	24-04-2003	BR 0203991 A	16-09-2003
			CA 2406490 A1	22-04-2003
			GB 2381021 A , B	23-04-2003
			NO 20025051 A	23-04-2003
			US 2003075333 A1	24-04-2003
US 2003136562	A1	24-07-2003	US 2003070811 A1	17-04-2003
			GB 2380749 A	16-04-2003
			NO 20024916 A	14-04-2003
US 6431282	B1	13-08-2002	AU 756966 B2	30-01-2003
			AU 4543600 A	14-11-2000
			BR 0009654 A	08-01-2002
			CA 2368885 A1	19-10-2000
			CN 1346422 T	24-04-2002
			EA 3240 B1	27-02-2003
			WO 0061914 A1	19-10-2000
			EP 1169548 A1	09-01-2002
			NO 20014902 A	05-12-2001
			NZ 514561 A	29-08-2003
			TR 200102848 T2	21-01-2002
US 6250385	B1	26-06-2001	FR 2765619 A1	08-01-1999
			GB 2326896 A , B	06-01-1999
US 3477506	A	11-11-1969	NONE	