

E. M. ROSENBLUTH.
ELECTRICALLY OPERATED WATER HEATER FOR AUTOMOBILE RADIATORS.
APPLICATION FILED JAN. 2, 1915.

1,155,098.

Patented Sept. 28, 1915.
2 SHEETS—SHEET 1.

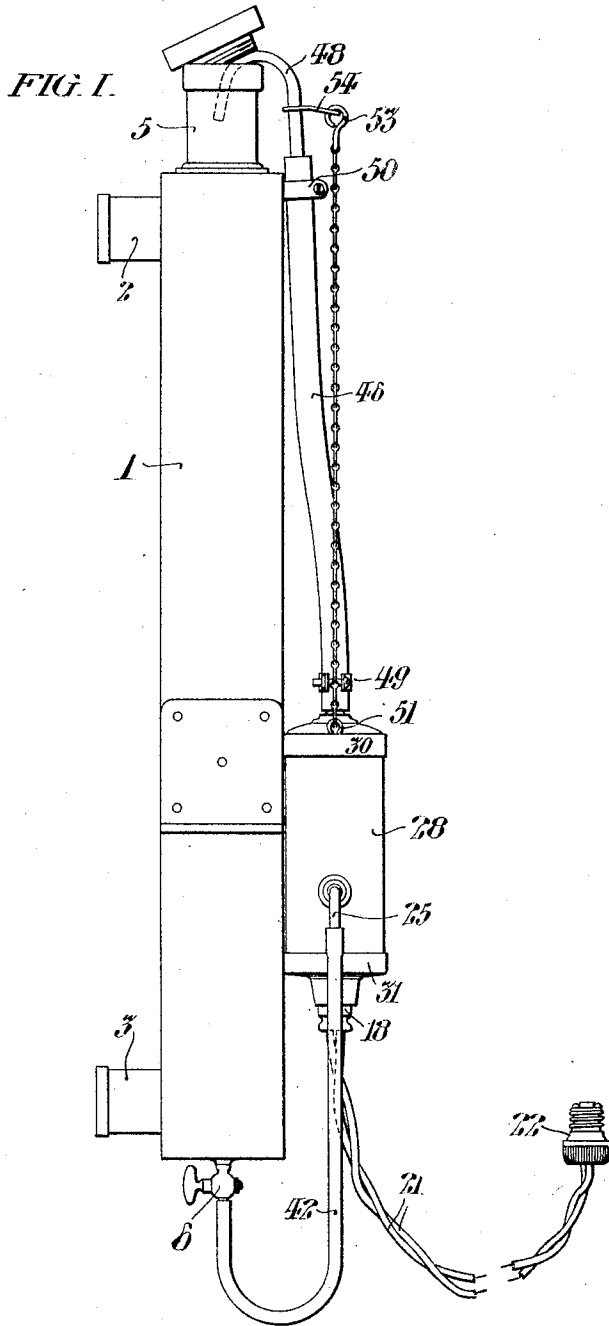

WITNESSES:
Anna Israelovitz
Philip W. Vessey

INVENTOR:
Edwin M. Rosenbluth
by Arthur E. Knight
Attorney

E. M. ROSENBLUTH.
 ELECTRICALLY OPERATED WATER HEATER FOR AUTOMOBILE RADIATORS.
 APPLICATION FILED JAN. 2, 1915.

1,155,098.

Patented Sept. 28, 1915.

2 SHEETS—SHEET 2.

FIG. II.

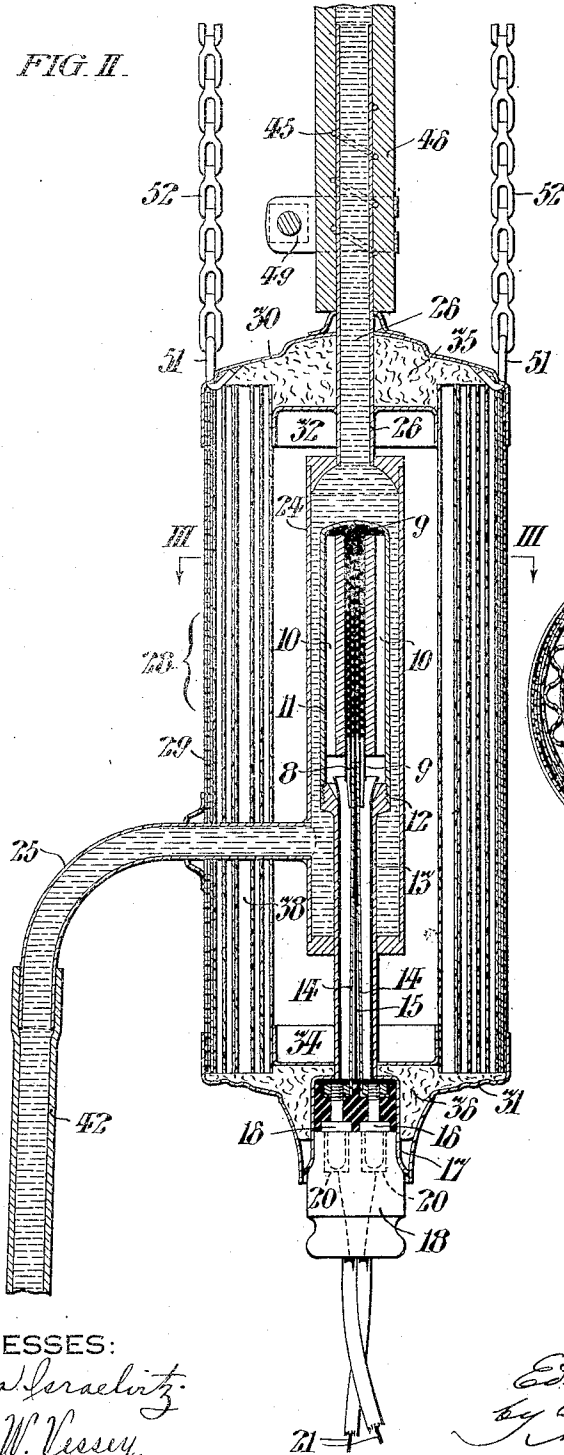
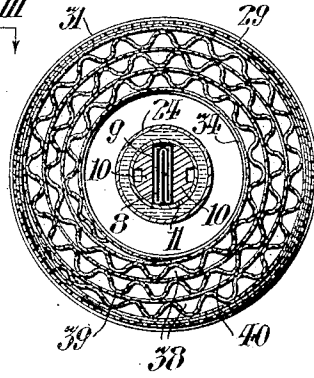

FIG. III.



WITNESSES:
Anna Israelowitz
Philip W. Vessey

INVENTOR:
Edwin M. Rosenbluth
 by *Arthur C. Saig*
Attorney

UNITED STATES PATENT OFFICE.

EDWIN M. ROSENBLUTH, OF PHILADELPHIA, PENNSYLVANIA.

ELECTRICALLY-OPERATED WATER-HEATER FOR AUTOMOBILE-RADIATORS.

1,155,098.

Specification of Letters Patent.

Patented Sept. 28, 1915.

Application filed January 2, 1915. Serial No. 3.

To all whom it may concern:

Be it known that I, EDWIN M. ROSENBLUTH, a citizen of the United States, residing at Philadelphia, in the State of Pennsylvania, have invented a certain new and useful Improvement in Electrically-Operated Water-Heaters for Automobile-Radiators, whereof the following is a specification, reference being had to the accompanying drawings.

My invention relates to heaters of the class contemplated in Letters Patent of the United States #774,556, granted November 8, 1904, of which I am the assignee, to wit, a heater for causing a circulation of warm or hot water through the water circulating system designed to cool an internal combustion motor of a self propelled vehicle; such heater being independent of said motor and employed to prevent freezing of the water in such a system when the latter is exposed to winter temperatures.

As hereinafter described, my invention includes an electric heating unit having flexible conductors with a terminal plug adapted to fit in any ordinary incandescent lamp socket or similar electric receptacle for connection with an energizing circuit; said heater being inclosed in a casing which is non-conductive of heat; said water chamber having flexible inlet and outlet tubes adapted for detachable connection with an automobile radiator; said inlet tube being adapted for connection with the ordinary drip cock at the bottom of the radiator, and said outlet tube having a hook shaped nozzle adapted to hang in the water inlet tube at the top of said radiator; the arrangement being such that water is received in said water chamber of the heater from the bottom of the radiator; heated in said chamber and discharged through said hook nozzle into the top of the radiator; said nozzle having flexible mechanical connectors extending to said heater to support the latter without strain upon said flexible water outlet tube.

My invention includes the various novel features of construction and arrangement hereinafter more definitely specified.

In the drawings; Figure I is a side elevation of an automobile radiator with a convenient embodiment of my invention applied thereto. Fig. II is a vertical sectional view of the heater shown in Fig. I, but on a larger

scale. Fig. III is a transverse sectional view of said heater taken on the line III, III in Fig. II.

Referring to Fig. I; the automobile radiator 1 may be of any suitable construction, connected with the water circulating system of the vehicle motor by the pipes 2 and 3 and having the water inlet tube 5 at its top and the drip cock 6 at its bottom.

Referring to Figs. II and III; the electric heating unit conveniently comprises a double coil of flat resistance wire 8 wrapped upon and inclosed by sheets of mica or other suitable insulating material 9 and held between the segmental cylindrical bars 10 in the casing 11 which is connected by the screw thread 12 with the tubular shank 13 through which extend the flat metal strip conductors 14 which are insulated by the sheet of mica 15 and in connection with the terminals 16 in the socket 17 which is adapted to receive the removable plug 18 having respective sockets 20 arranged to detachably engage said terminals 16 when said plug 18 is thrust into said socket 17, as shown in Fig. II. Said sockets 20 are electrically connected with the flexible conductors 21 leading to the screw plug 22 which may be of any suitable construction to fit an ordinary incandescent lamp socket or similar receptacle in connection with a circuit including a source of electricity by which said resistance coils of wire 8 may be raised to any desired temperature. Said casing 11 of the electric heating unit above described, is inclosed in the water chamber 24 having the water inlet tube 25 at the bottom thereof and the water outlet tube 26 at the top thereof, extending through and in rigid relation with the casing 28 which is designed to be non-conductive of heat and includes the outer shell 29 of perforated sheet metal having the outer caps 30 and 31 respectively at the top and bottom thereof and the inner flanged heads 32 and 34, respectively at the top and bottom of said casing 28, in spaced relation with said caps so as to afford a space between them for packings 35 and 36 of heat insulating material, for instance asbestos or mineral wool, bearing upon the ends of the cylindrical cellular jacket 38 extending between said shell 29 and the flanges on said heads 32 and 34, by which it is held in rigid position in said casing 28. Said

jacket is conveniently made of a sheet of primarily plane asbestos paper 39 having attached upon one surface a corrugated sheet of such paper 40 and wrapped in an involute coil as shown in Fig. III. Said rigid water inlet tube 25, which is made of metal, is bent downwardly at its outer end, as shown in Fig. II, for convenient connection with the flexible tube 42, preferably rubber, which extends in connection with said drip cock 6, as shown in Fig. I, so that the water from the radiator 1 is directed into said water chamber 24 of the heater. Said rigid water outlet tube 26, which is made of metal, is conveniently provided with the spiral ridge 45, formed by a coil of wire, for engagement with the flexible tube 46, preferably hose formed of rubber reinforced with textile fabric, which extends in connection with the hook nozzle 48 through which the water from said chamber 24 is returned to the radiator 1, by way of the inlet tube 5 of the latter on which the heater is hung, by said hook nozzle, as shown in Fig. I. Although said hose 46 may be retained in connection with said water outlet tube 26 and nozzle 48 by frictional engagement therewith, I prefer to secure it thereto by the respective screw clamp bands 49 and 50. Moreover, in order to support the heater without strain upon said hose 46, I provide the heater casing 28 with eyes 51 at diametrically opposite sides thereof, in engagement with chains 52 having the common link 53 at their upper ends hung in the bracket plate 54 which is rigidly connected with said nozzle 48.

The apparatus above described may be operated as follows:—Ordinarily the radiator drip cock 6 is shut and said apparatus removed from the radiator and the water chamber 24 empty. However, the heater may be instantaneously suspended in operative relation with the radiator by hooking the nozzle 48 in the radiator water inlet tube 5, connecting the flexible tube 42 with the drip cock 6, while the latter is closed, and then opening the same so that the water from the radiator flows into the heater and fills the chamber 24 thereof and the water outlet 26 therefrom to the top of the radiator. As the water level in the heater outlet must rise higher than the water level in the radiator, in order to discharge into the latter, such discharge is effected intermittently, the action being pulsatory; the water in the heater being raised in temperature until a portion thereof is discharged through the nozzle 48 simultaneously with the induction of a corresponding quantity of cold water from the radiator; the flow from the nozzle 48 ceasing until the temperature is again raised to such a degree as to effect such pulsatory discharge and influx, at a rate deter-

mined by the temperature of said resistance coils 8.

The operation of the heater with respect to the radiator 1 may be instantly terminated by closing the radiator drip cock 6, slipping the flexible water inlet tube 42, of the heater, from said cock, and unhooking the nozzle 48 from the radiator water inlet tube 5, in which the water contents of the heater may be emptied if desired; said tube 42 being compressible to prevent leakage of water therefrom or until the apparatus is inverted to thus empty it. Of course, if it is not desired to discharge the hot water from the heater into the radiator when the operation aforesaid is terminated, the water may be allowed to drain from the tube 42.

I do not desire to limit myself to the precise details of construction and arrangement herein set forth as it is obvious that various modifications may be made therein without departing from the essential features of my invention as defined in the appended claims.

I claim:—

1. A water heater including an electric heating unit having a closed casing and terminals for connection with an energizing circuit; a casing forming a water chamber surrounding said electric heating unit and having a water inlet tube near the bottom thereof and a water outlet tube at the top thereof; a heat insulating casing including an outer shell surrounding said water chamber, in spaced relation therewith; both of said tubes being in rigid relation with both of said casings; a flexible water inlet tube extending from said rigid inlet tube; a flexible water outlet tube extending from said rigid outlet tube and having at the upper end thereof a hook shaped nozzle; and a flexible mechanical connection between said heater casing and said hook nozzle, of less length than said flexible water outlet tube; whereby said heater is suspended from said hook nozzle without strain upon said flexible tube connections.

2. A water heater including an electric heating unit having terminals for connection with an energizing circuit; a casing forming a water chamber surrounding said electric heating unit and having a water inlet tube near the bottom thereof and a water outlet tube at the top thereof; both of said tubes being in rigid relation with said casing; a flexible water outlet tube extending from said rigid outlet tube and having at the upper end thereof a hook shaped nozzle; and a flexible mechanical connection between said heater casing and said hook nozzle, of less length than said flexible water outlet tube; whereby said heater is suspended from said hook nozzle without strain upon said flexible tube connections.

3. A water heater including an electric

heating unit having terminals for connection with an energizing circuit; a casing forming a water chamber surrounding said electric heating unit and having a water inlet tube and a water outlet tube; both of said tubes being in rigid relation with said casing; and a flexible water outlet tube extending from said rigid outlet tube and having at the upper end thereof a hook shaped nozzle; whereby said heater is suspended from said hook nozzle without strain upon said flexible tube connections.

4. A water heater including an electric heating unit having terminals for connection with an energizing circuit; a casing forming a water chamber surrounding said electric heating unit and having a water inlet, at the bottom thereof, and a water outlet at the top thereof; and means arranged to maintain a current of water to, through and from said chamber, including a flexible water outlet tube extending from said outlet and having at the upper end thereof a hook shaped nozzle whereby said heater may be suspended and through which the water is discharged.

5. A water heater including a heating unit; a casing forming a water chamber surrounding said unit and having a water inlet at the bottom thereof and a water outlet at the top thereof; and a water outlet tube leading from said casing outlet and having a hook nozzle whereby said heater may be suspended and through which the water is discharged.

6. The combination with a radiator having a water inlet and a water outlet; of a water heater including a heating unit in a water chamber having a water inlet and a water outlet; means arranged to circulate water in and between said radiator and heater, including a water conduit leading from said radiator outlet to said heater inlet; a water tube leading from said heater outlet to said radiator inlet; and a hook nozzle on said tube whereby said tube is suspended from said radiator and through which the water is directed into said radiator inlet.

7. The combination with a radiator having a water inlet at the top thereof and a water outlet at the bottom thereof; of a water heater detachably connected with said radiator, including a heating unit in a water chamber having a water inlet to the bottom thereof and a water outlet from the top thereof; a water conduit leading from said radiator outlet to said heater inlet; a water tube leading from said heater outlet to said radiator inlet, and extending above the latter; whereby water from said radiator is caused to circulate through said heater; the flow to and from said radiator being inter-

mittent and pulsatory at a rate predetermined by the temperature of said heating unit.

8. A water heater including a heating unit; a casing forming a water chamber surrounding said unit and having a water inlet and a water outlet; a foraminous cylindrical outer casing shell surrounding said water chamber, in spaced relation therewith; outer caps respectively at the top and bottom of said shell, holding the latter in rigid concentric relation with said water chamber; inner flanged heads, respectively at the top and bottom of said shell, in spaced relation with said caps; a cylindrical cellular jacket of heat insulating material extending between said shell and heads, including an involute coil of sheet material having its convolutions in spaced relation, and a corrugated sheet extending between said convolutions; and packings of heat insulating material, between said caps and heads, bearing upon the ends of said jacket and holding the same in rigid relation with said shell.

9. A water heater including a heating unit; a casing forming a water chamber surrounding said unit and having a water inlet and a water outlet; an outer casing shell surrounding said water chamber, in spaced relation therewith; outer caps respectively at the top and bottom of said shell, holding the latter in rigid concentric relation with said water chamber; inner flanged heads, respectively at the top and bottom of said shell, in spaced relation with said caps; a cellular jacket of heat insulating material extending between said shell and heads; and packings of heat insulating material, between said caps and heads, bearing upon the ends of said jacket and holding the same in rigid relation with said shell.

10. A water heater including a heating unit; a casing forming a water chamber surrounding said unit and having a water inlet and a water outlet; an outer casing shell surrounding said water chamber, in spaced relation therewith; outer caps respectively at the top and bottom of said shell, holding the latter in rigid concentric relation with said water chamber; inner flanged heads, respectively at the top and bottom of said shell, in spaced relation with said caps; and a cellular jacket of heat insulating material extending between said shell and heads.

In testimony whereof, I have hereunto signed my name at Philadelphia, Pennsylvania, this twenty-eighth day of December, 1914.

EDWIN M. ROSENBLUTH.

Witnesses:

W. H. KILLE,
E. G. McCULLOUGH.