

March 25, 1969

E. R. JABLONSKI

3,435,202

LUMINAIRE

Filed Aug. 10, 1966

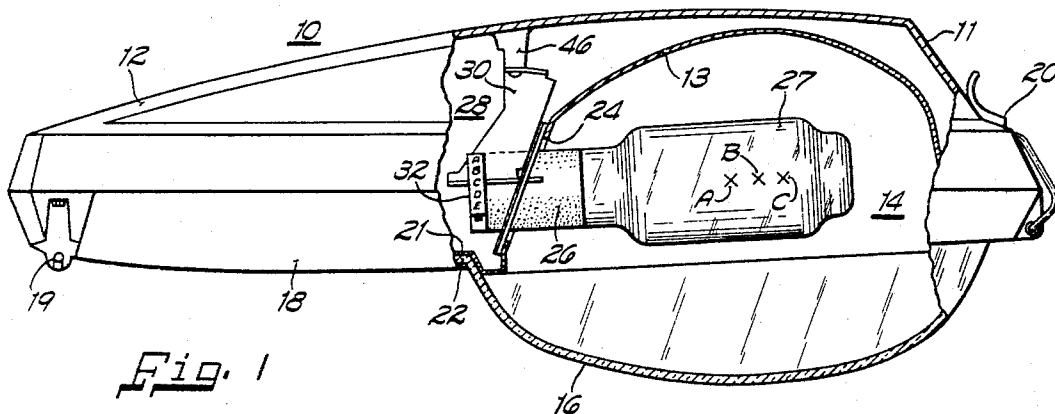

Fig. 1

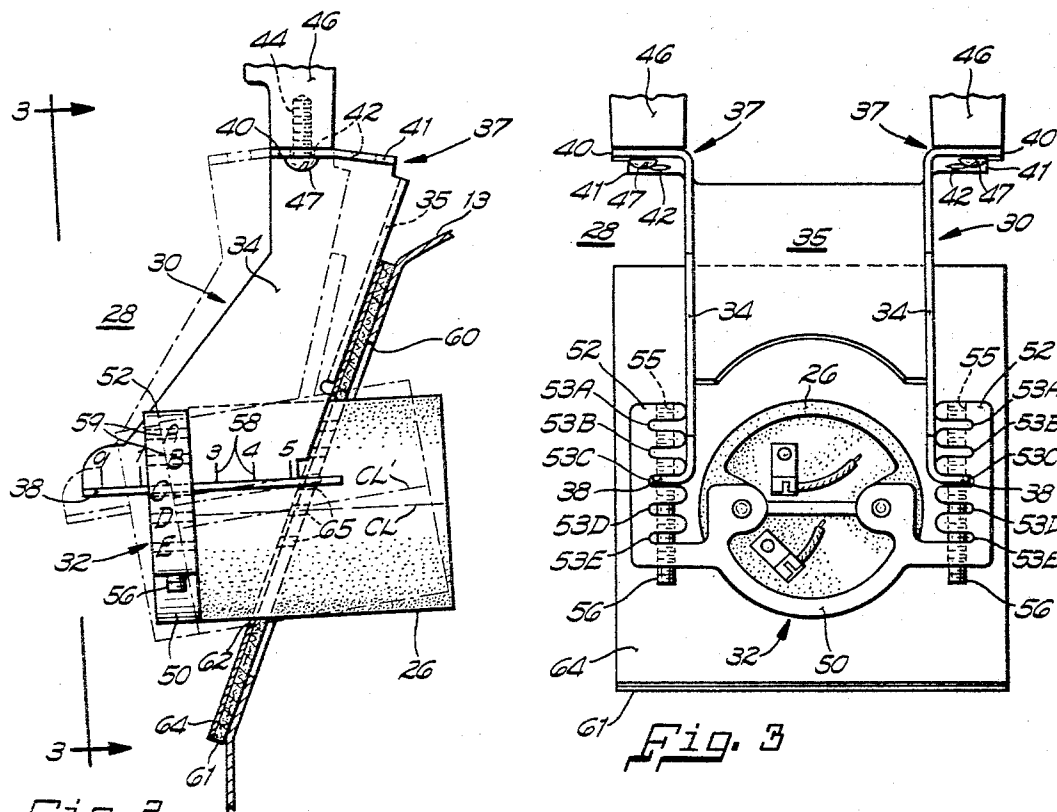

Fig. 2

Fig. 3

Inventor.  
Edward R. Jablonski  
By Fred Winiott  
Attorney

1

2

3,435,202  
LUMINAIRE

Edward R. Jablonski, South Milwaukee, Wis., assignor  
to McGraw-Edison Company, Milwaukee, Wis., a corporation of Delaware

Filed Aug. 10, 1966, Ser. No. 571,473

Int. Cl. F21s 3/10

U.S. Cl. 240—25

12 Claims

## ABSTRACT OF THE DISCLOSURE

A luminaire assembly including a housing, a reflector and an adjustable lamp socket support for varying in two dimensions the position of the lamp with respect to the reflector to vary the light pattern produced by the luminaire. The assembly further includes a gasket surrounding a lamp socket and slideable relative to the reflector to maintain a dust shield between the lamp socket and the reflector as the lamp socket is moved to vary the light pattern.

This invention relates to luminaires and more particularly to new and improved means for mounting the lamp holding means of horizontal type luminaires.

Luminaires having horizontally mounted lamps are generally available in 250 watt, 400 watt and 1000 watt sizes. Also available is a variety of optical assemblies for providing various light distribution patterns. In addition, a number of lamp types, such as mercury vapor, ceramic discharge and metallic halide, may be employed in horizontally mounted luminaires. The light center, that is the location at which the lamp must be mounted relative to the luminaire's optical assembly, differs for each of the various luminaire sizes, lamp types and optical assemblies. Accordingly, it was necessary to stock a large number of lamp socket support brackets so that each of the various light centers or lamp mounting positions could be achieved.

It is an object of the invention to provide lamp holder support means which is constructed and arranged for supporting a lamp in any of a plurality of positions relative to the luminaire so that a single lamp socket support means may be employed in various sized luminaires and with various lamp types and optical assemblies.

These and other objects and advantages of the instant invention will become more apparent from the detailed description thereof taken with the accompanied drawings wherein:

FIG. 1 is a side elevational view, partly in section, showing a luminaire incorporating a lamp holder support according to the instant invention;

FIG. 2 is a fragmentary view of luminaire illustrated in FIG. 1 and which shows the lamp holder support means in greater detail; and

FIG. 3 is a view taken along lines 3—3 of FIG. 2.

In general terms the invention comprises support means for a luminaire lamp socket having selective mounting means constructed and arranged to releasably support the lamp socket in a plurality of positions within the luminaire housing, wherein the lamp socket positions vary two dimensionally with respect to the longitudinal axis of the luminaire.

Referring now to the drawings in greater detail, FIG. 1 shows a horizontally mounted luminaire 10 which includes a generally ovate housing 11 having an elongate portion 12 integrally formed on one side thereof for enclosing a slipfitter assembly (not shown) which permits attachment of the luminaire to a horizontally extending pipe support member (not shown).

The luminaire 10 includes an optical assembly 14 which comprises an ovate reflector 13 mounted within the

housing 11 and a cooperating refractor 16. The refractor 16 is mounted on a bottom closure member 18 which is supported at one end beneath the slipfitter housing 12 by a hinge assembly 19 to permit pivotal movement in a clockwise direction as viewed in FIG. 1 so that the under side of the housing may be exposed for relamping and other maintenance purposes.

A quick release latch assembly 20 is provided at the opposite side of the closure member 18 so that the latter may be held in its closed position shown in FIG. 1 whereby a peripheral flange 22 on the refractor 16 is held in cooperating sealed engagement with a peripheral flange 21 on the reflector 13. Means, which are not shown but which are well known in the art, are provided for releasably securing the refractor 16 in the bottom closure member 18 and the reflector 13 in the housing 11. For a more complete description of a luminaire incorporating the above discussed features of luminaire 10, reference is made to U.S. Patent 3,204,092 issued Aug. 31, 1965, and assigned to the assignee of the instant invention.

As seen in FIG. 1, the end of reflector 13 opposite the latch 20 is provided with an aperture 24 for receiving therethrough a lamp socket 26 which supports a lamp 27 within the optical assembly 14. The lamp socket 26 is supported within the housing 11 by a lamp socket support assembly 28 and is connected to a source of energy (not shown) in a manner well known in the art.

In the illustrated embodiment the lamp 27 is mounted with its light center at position A, such as for example would be the case if the luminaire optical assembly 13 were to provide one light distribution pattern. On the other hand, if the luminaire optical assembly 14 were of a different type whereby a different light distribution pattern were provided, it might be necessary to position the lamp 27 with its light center at points B or C.

The lamp socket support assembly 28 is shown in FIGS. 2 and 3 to bracket 30 and a lamp socket support member 32. The bracket 30 is mountable in at least a pair of angular positions relative to the housing 11 for changing the inclination of the longitudinal axis of the lamp 27. In addition the lamp socket support member 32 is selectively mountable on the bracket 30 so that the axis of the lamp may be moved longitudinally and/or transversely relative to the optical assembly 14.

The bracket 30 comprises a unitary member formed from a flat stamping which has been bent to provide a pair of planar, generally parallel side portions 34 which are interconnected by a central web portion 35 generally normal to the side portions 34. The upper and lower ends of each of the side portions 34 are bent outwardly at substantially right angles to form a pair of mounting ears 37 at their upper ends and a pair of socket support flanges 38 at their lower ends.

Each of the mounting ears 37 comprise first and second planar portions 40 and 41 wherein the second portion 41 is tilted downwardly through an angle relative to the portion 40. In addition each of the planar portions 40 and 41 has an aperture 42 which registers with threaded holes 44 formed in each of a pair of bosses 46 extending downwardly from the housing 11 so that the bracket 30 may be secured to the bosses 46 by screws 47.

When the bracket 30 is mounted by the first planar portions 40 of ears 37, as shown by full lines in FIG. 2, the center line CL of socket 36 has a first angular relation with respect to the housing 11. On the other hand, when the bracket 30 is mounted by the second planar portions 41 as shown by broken lines in FIG. 2, the center line of socket 26 is tilted upwardly at a second angle relative to the housing 11 as indicated by the reference CL'. In this manner socket 26, and hence the lamp 27 may be mounted at different angular positions relative to the housing 11 as

may be required by the angular relation of the optical assemblies of various size luminaires. It will be appreciated by those skilled in the art that by the provision of additional planar portions to the ears 37 it will be possible to tilt the center line CL of the socket 26 through additional vertical angles.

The lamp socket support member 32 is shown in FIGS. 2 and 3 to include a generally arcuate socket mounting portion 50 and a pair of arm portions 52 which are integral with and extend tangentially away from the socket mounting portion 50. Each of the arm portions 52 has a plurality of generally parallel, equi-spaced transverse slots 53A-53E which open inwardly toward the socket mounting portion 50. The slots 53 are of a width and are sufficiently spaced from the opposed slots in the other arm 52 to slidably receive the support flanges 38 of the support bracket 30. In addition, a threaded bore 55 is formed longitudinally through each arm 52 and intersecting each of the slots 53A-53E for receiving set screws 56 so that the socket support member 32 may be releasably secured to the support flanges 38.

As seen in FIG. 2 the side portions 34 of bracket 30 are provided with a scale 58 which measures distances along the mounting flange 38. In addition a second set of indicia 59, which consists of letters A-E mark the positions of the slots 53A-53E on the arms 52.

As seen in FIG. 2 the socket mounting member 32 is mounted on the bracket member 30 at position 2C wherein slots 53C engage the support flanges 38 and the socket support member 32 is located at the second position along the scale 58.

It will be appreciated that by loosening the set screws 56, the socket support member 32 may be moved to any predetermined position along the support flanges 38 as measured by the scale 58. This will move the socket 26, and hence the lamp 27 longitudinally relative to the optical assembly 13. The position of the socket support member 32 will be governed by the IES type light pattern desired and will be determined beforehand.

In addition the light socket support member 32 may be completely removed from the support flanges 38 and re-mounted thereon at one of the other slots 53A, 53B, 53D or 53E. Thus, if the lamp type requires raising the socket 26 relative to the optical assembly 14, the support member 32 may be mounted on flange 38 at one of the slots 53D or 53E depending upon the degree of elevation desired. On the other hand if it is necessary to lower the lamp 27, the socket support member 32 may be mounted on flange 38 at one of the slots 53A or 53B depending upon the degree of the depression required.

It will be appreciated from the foregoing that with the light socket mounting assembly 28 according to the instant invention, the lamp 27 may be moved longitudinally or transversely on the optical assembly by moving the light socket support member 32 relative to the support flange 38. In addition the longitudinal axis of the lamp 27 may be mounted in various angles relative to the optical assembly by selectively securing the support bracket 30 to the housing 11 at one or the other of its planar ear portions 40-42.

In order to permit the above discussed movement of the light socket 26, the reflector 13 is provided with an elliptical aperture 60 which is sealed by a gasket plate 61 provided between the lamp socket support 28 and the reflector 13. The gasket plate 61 has an aperture 62 for being slidably received on the lamp socket 26 and may be composed of felt and have a metallic backing plate 64. The gasket plate 61 is held in position by a plurality of apertures 65 which correspond to the slots 53A-53E in the socket mounting member 32 and which receive the ends of the mounting flanges 38. By placing the ends of the mounting flanges 38 in those apertures in gasket plate 61 which correspond to the slots 53 engaged by said flanges, the gasket plate 61 will always be in the same position

relative to the reflector 13 regardless of the position of the lamp socket 26.

While the invention has been illustrated and described with respect to one particular type of horizontally mounted luminaire, those skilled in the art will appreciate that it has application to other types of luminaires as well. In addition while only a single embodiment of the invention has been illustrated, other modifications thereof will become apparent once the inventive concept is known. Accordingly, it is not intended that the invention be limited to the foregoing description but only by the scope of the appended claims.

I claim:

1. In a luminaire having a housing, an optical assembly disposed in said housing and having a longitudinal axis, a lamp assembly comprising a lamp socket and a lamp supported thereby in said optical assembly, said lamp and lamp socket being aligned along a lamp assembly axis which is substantially parallel to the direction of said longitudinal axis, lamp socket support means for supporting said lamp assembly within said housing for selectively positioning said lamp assembly in any one of a plurality of positions spaced apart transversely with respect to said longitudinal axis, the alignment of said lamp assembly axis being substantially parallel to said longitudinal axis in each of said positions, said support means comprising a first means having a plurality of parallel spaced apart slots, each being parallel to said longitudinal axis, and second means having slot engaging means for selectively engaging at least one of said slots.

2. The invention as defined in claim 1 in which said slot engaging means is slideable within said slots for moving said lamp holder in the direction of said lamp assembly axis.

3. The invention as defined in claim 1, together with gasket means surrounding said lamp holder and overlying a portion of said reflector in sliding engagement therewith, whereby said gasket means is movable with said lamp socket as said lamp socket is moved between said spaced apart positions of said lamp assembly.

4. The invention as defined in claim 3, in which said gasket means comprises gasket plate means surrounding said lamp socket for forming a seal between said lamp socket and said reflector, said gasket plate means having spaced apart means corresponding by proportionate spacing to said slots, and means on said reflector at least one of said spaced apart means for supporting said gasket plate means in positions corresponding to the spaced apart positions of said lamp assembly.

5. The invention as defined in claim 4 in which said slot engaging means is slideable within said slots and said lamp socket is slideable within said gasket plate means, whereby said lamp holder is movable in the direction of said lamp assembly axis.

6. The invention as defined in claim 2, together with set screw means threadingly engaging said first means and passing through said first means perpendicular to said slots for engaging said slot engaging means in various ones of said slots and for thereby locking said slot engaging means against sliding movement relative to said slots.

7. In a luminaire having a housing, an optical assembly disposed in said housing and having a longitudinal axis, a lamp socket for supporting a lamp in said optical assembly, lamp socket support means including selective mounting means engaging said lamp socket and being constructed and arranged to releasably support said lamp socket in a plurality of positions within said housing, said positions being in a two dimensional relationship so that said lamp may be positioned within said optical assembly in a plurality of positions which vary two dimensionally with respect to said longitudinal axis, said lamp socket support means including first means securable to said housing and second means for securing said lamp socket to said first means, said first means including mounting

5

means for mounting said lamp socket in any of a plurality of vertical angular positions, said latter mentioned mounting means including a plurality of angularly disposed planar ear portions and means for selectively securing said ear portions to said housing.

8. In a luminaire having a housing, an optical assembly disposed in said housing and having a longitudinal axis, a lamp socket for supporting a lamp in said optical assembly, lamp socket support means including selective mounting means engaging said lamp socket and being constructed and arranged to releasably support said lamp socket in a plurality of positions within said housing, said positions varying in a two dimensional relationship so that said lamp may be positioned within said optical assembly in a plurality of positions which vary two dimensionally with respect to said longitudinal axis, said selective mounting means including a first member securable to said housing and a second member securable to said lamp socket, one of said first and second members having a plurality of indexing means arranged in a direction generally transverse to the longitudinal axis of said optical assembly and constructed and arranged for affixing said second member to said first member in one of a plurality of positions transverse to said axis, said first member including mounting means for mounting said lamp socket in any one of a plurality of vertical angular positions, and said latter mentioned mounting means including a plurality of angularly disposed planar ear portions and means for selectively securing said ear portions to said housing.

9. The luminaire set forth in claim 8 wherein said first member includes elongate support portions extending in a direction generally parallel to said axis and wherein said indexing means is provided on said second member and includes a plurality of equally spaced support portion engaging means.

10. The luminaire set forth in claim 9 wherein said first member includes position marking indicia adjacent said elongate support portion, and said second member includes indicia marking the position of each of said support portion engaging means.

11. In a luminaire having a housing, an optical assembly disposed in said housing and having a longitudinal axis, a lamp socket for supporting a lamp in said optical assembly, lamp socket support means including selective mounting means engaging said lamp socket and being

6

constructed and arranged to releasably support said lamp socket in a plurality of positions within said housing, said positions varying in a two dimensional relationship so that said lamp may be positioned within said optical assembly in a plurality of positions which vary two dimensionally with respect to said longitudinal axis, said selective mounting means including a first member securable to said housing and a second member securable to said lamp socket, one of said first and second members having a plurality of indexing means arranged in a direction generally transverse to the longitudinal axis of said optical assembly and constructed and arranged for affixing said second member to said first member in one of a plurality of positions transverse to said axis, said first member including a plurality of angularly disposed mounting portions which may be selectively secured to said housing so that said lamp socket may be mounted in any one of a plurality of vertical angular positions, said first member further including an elongate support portion extending in a direction generally parallel to said axis, and said second member further including indexing means provided on said second member, including a plurality of equally spaced support portion engaging means.

12. The luminaire set forth in claim 11 wherein said first member includes position marking indicia adjacent said elongate support portion and said second member includes indicia marking the position of each of said support portion engaging means.

#### References Cited

##### UNITED STATES PATENTS

Re. 25,900	11/1965	Husby et al. ....	240—25
2,536,710	1/1951	Baker .....	240—52
2,977,461	3/1961	Jones .....	240—44.2 X
3,043,950	7/1962	Keck .....	240—25
3,065,338	11/1962	Husby et al. ....	240—25
3,102,693	9/1963	Rex .....	240—25
3,204,092	8/1965	Jablonski .....	240—25
3,299,263	1/1967	Bjontegard .....	240—25

NORTON ANSHER, *Primary Examiner.*

WAYNE A. SIVERTSON, *Assistant Examiner.*

U.S. Cl. X.R.

240—44.2