

[54] METHOD AND APPARATUS FOR POSITIONING A COFFERDAM

[75] Inventor: John R. Mittleman, Arlington, Mass.

[73] Assignee: The United States of America as represented by the Secretary of the Navy, Washington, D.C.

[22] Filed: Jan. 2, 1974

[21] Appl. No.: 430,120

[52] U.S. Cl. 61/68, 114/227

[51] Int. Cl. B63c 11/00, B63c 11/30

[58] Field of Search 61/68, 69; 114/227, 229, 114/222

[56] References Cited UNITED STATES PATENTS

704,905	7/1902	McLaughlin	114/227
1,060,177	4/1913	Fluceltaub	61/68

Primary Examiner—Jacob Shapiro

Attorney, Agent, or Firm—Richard S. Sciascia; Joseph M. St. Amand; Darrell E. Hollis

[57] ABSTRACT

A method and apparatus for positioning a cofferdam against a submerged surface. Weights are attached to the cofferdam such that the center of gravity of the cofferdam is closer to the submerged object than the center of gravity of the weights and above the center of gravity of the weights. Lifting eyes are attached to the cofferdam above its center of gravity from which cables extend. The cables support and position the cofferdam. The placement of the weights in relation to the lifting eyes create a moment which maintains contact between the cofferdam and the submerged object.

6 Claims, 4 Drawing Figures

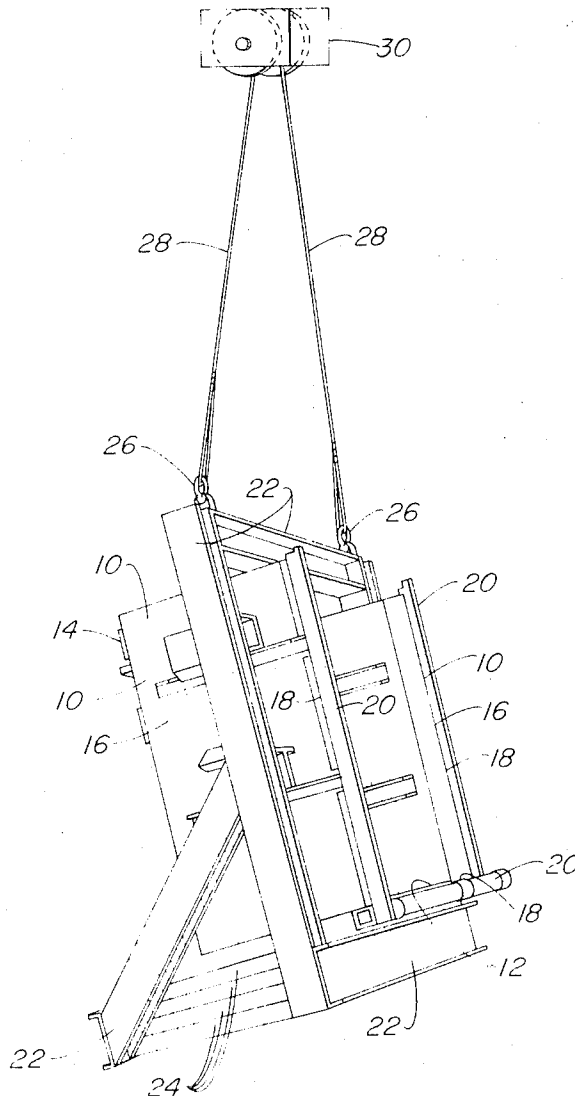

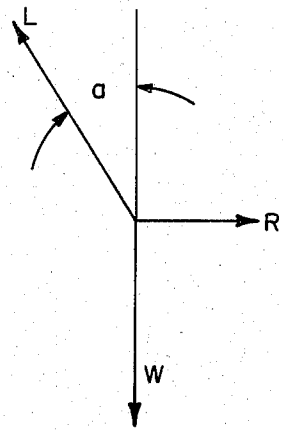
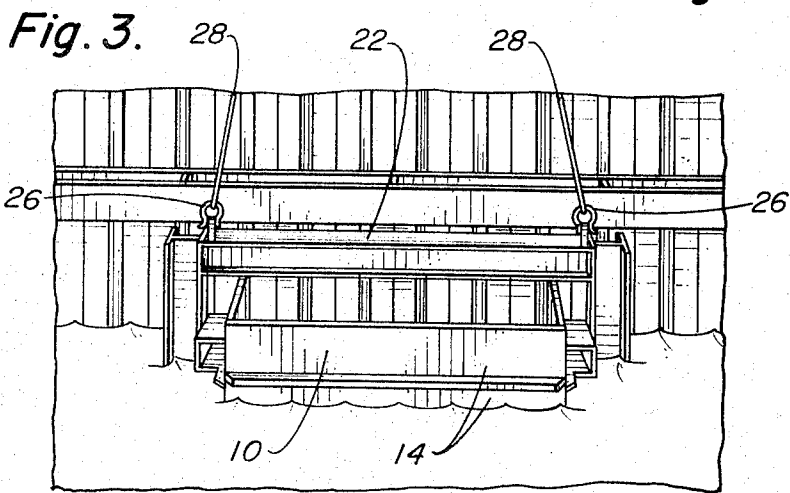
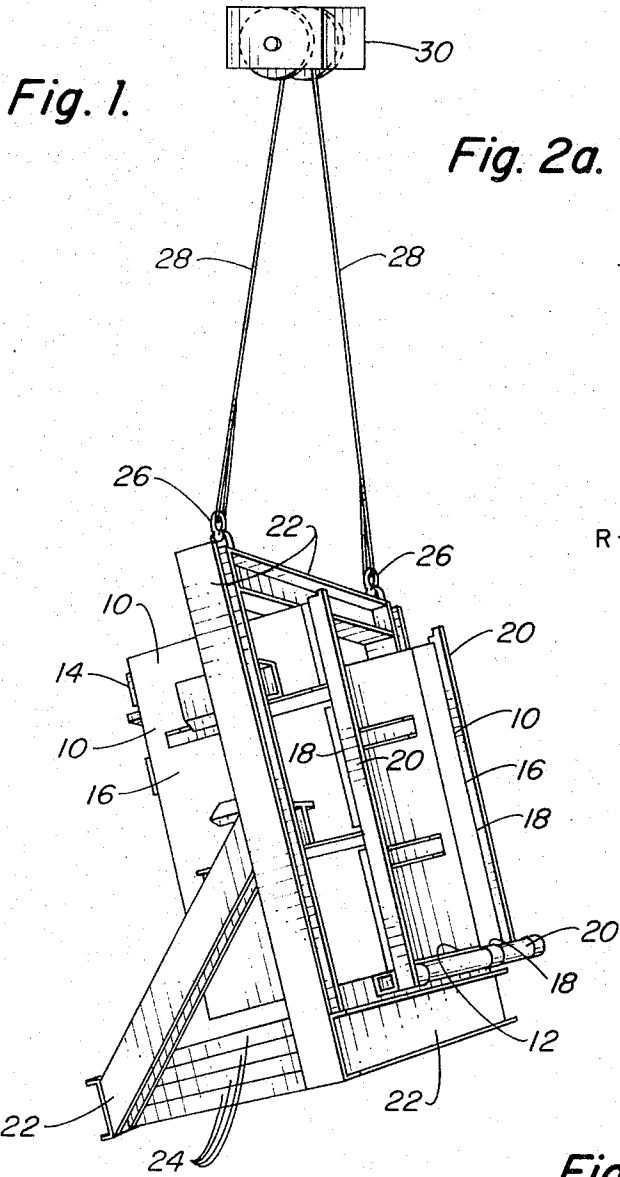

METHOD AND APPARATUS FOR POSITIONING A COFFERDAM

BACKGROUND OF THE INVENTION

1. Field of the Invention

The present invention relates generally to cofferdams and more particularly to cofferdams having weights attached thereto.

2. Description of the Prior Art

Once a cofferdam is positioned in the water and the process of expelling the water from inside the cofferdam begins, the cofferdam becomes buoyant and tremendous forces tend to force the cofferdam out of the water. These forces must be countered in order for the cofferdam to maintain its position.

Some prior art devices accomplish this task by bolting or tying the cofferdam to the submerged surface. Such methods require drilling and tapping holes where the structural integrity of the material of the submerged surface is questionable. Such an installation requires divers with special tools and training to perform the underwater operations. Also, there is the ever present danger of the tyings coming loose and attendant danger to workers.

Other prior art devices accomplish the task by driving stakes into the water bottom and attaching the cofferdam thereto. This method also requires divers and creates an extremely dangerous work environment.

Another prior art device utilizes ballast tanks attached to the cofferdam to accomplish this task. However, due to the size of the ballast tank used (the volume of these tanks will be nearly equal to the volume of the cofferdam itself), a bulky and expensive device is created. Accordingly, such devices cannot be utilized in cramped water spaces—a severe limitation. In addition, additional ballast tanks, if necessary, must be located above the water level. Since any ballast tanks located above the water must be seaward of the submerged surface, they will create a moment tending to tear the cofferdam away from the submerged object—a most undesirable effect, considering the slightness of wall friction between the cofferdam and the submerged object.

SUMMARY OF THE INVENTION

The general purpose of the present invention is to provide a cofferdam that is smaller, easier to maneuver, safer to position, safer for workmen and is less expensive than prior art devices. To attain this, the present invention provides a cofferdam having weights attached thereto such that the center of gravity of the cofferdam is closer to the submerged surface than the center of gravity of the weights and above the center of gravity of the weights. Lifting eyes are attached to the cofferdam above its center of gravity from which cables extend. The cables support and position the cofferdam. The placement of the weights in relation to the lifting eyes create a moment which maintains contact between the cofferdam and the submerged object.

Accordingly, an object of the present invention is to reduce size without reducing effective workspace of a cofferdam.

Another object of the present invention is to increase maneuverability of a cofferdam.

Another object of the present invention is to increase safety in positioning and use of a cofferdam.

Another object of the present invention is to reduce the number of manhours as well as the number of workmen required to position a cofferdam.

Another object of the present invention is to reduce cost.

Another object of the present invention is to reduce the specialized skills required to position a cofferdam.

Another object of the present invention is to maintain negative buoyancy at all times.

Another object of the present invention is to eliminate diver assistance in positioning a cofferdam.

Another object of the present invention is to minimize the amount of support equipment needed to position a cofferdam.

Other objects and a more complete appreciation of the present invention and its many attendant advantages will develop as soon as the same becomes better understood by reference to the following detailed description when considered in connection with the accompanying drawings in which like reference numerals designate like parts throughout the figures thereof and wherein:

BRIEF DESCRIPTION OF THE DRAWINGS

FIG. 1 is an isometric drawing of a specific embodiment of the present invention.

FIGS. 2a and 2b are diagrams of the forces and moments of the specific embodiment of FIG. 1.

FIG. 3 illustrates the specific embodiment of FIG. 1's placement.

DETAILED DESCRIPTION OF THE PREFERRED EMBODIMENT

the specific embodiment described, infra, of a cofferdam or water-tight device for making repairs below the waterline of a body of water has been developed primarily for use adjacent steel sheet piling surfaces, such as in FIG. 3, for example, although it also may be employed adjacent other surfaces where water must be temporarily kept away in order to provide periodic maintenance thereof.

Referring now to FIGS. 1 and 3, a cofferdam is represented by the numeral 10. The cofferdam 10 has a floor 12, a rear wall 14, and two side walls 16. Side walls 16 and floor 12 have edges 18 for abutting against an underwater object to be repaired. It will be appreciated by those skilled in the art that underwater surfaces have contours to which edges 18 must conform. Cofferdam 10 is water tight at the junctions of floor 12, rear wall 14 and side walls 16.

It is noted that cofferdam 10 may be made of plywood, aluminum, steel, or other suitable material.

A means for effecting a water-tight seal between edges 18 of cofferdam 10 and the underwater surface is designated by numeral 20. Means 20 comprises neoprene, urethane, rubber or other suitable resilient material attached to edges 18.

Attached to and conforming to the contour of cofferdam 10 is frame 22. Frame 22 strengthens cofferdam 10 as well as providing a means for supporting weights 24. Weights 24 provide cofferdam 10 with a net negative buoyancy. The center of gravity of weights 24 and frame 10 is below the center of gravity of cofferdam 10 and means 20 and a horizontal distance toward rear wall 14 from the center of gravity of cofferdam 10 and means 20. It is noted that the center of gravity of

weights 24 and frame 22 may be located behind the seaward side of rear wall 14. Weights 20 in the specific embodiment of FIG. 1 are steel plates which, of course, have a specific gravity of greater than one when compared with the water which is being displaced.

Attached to the top of frame 22 are two lifting eyes 26. Attached to lifting eyes 26 are flexible cables 28. Flexible cables 28 are attached to means for raising and lowering cofferdam 10 designated by numeral 30.

Frame 22, Lifting eyes 26, and means 30 comprise a means for supporting and positioning cofferdam 10, means 20, frame 22 and weights 24. It is noted that means 30 can move cofferdam 10 in three dimensions. Lifting eyes 26 are located above the center of gravity of cofferdam 10 and means 20. Lifting eyes 20 must be located a horizontal distance toward the underwater surface from the center of gravity of frame 22 and weights 24 for reasons to be discussed, infra.

It is noted that no divers or other underwater personnel are needed to position cofferdam 10. The requisite amount of weight 24 is connected to frame 22, cofferdam 10 and related parts are lowered into the water, cofferdam 10 is abutted against the underwater surface, and the water inside cofferdam 10 is expelled.

Now turning to FIG. 2a, cofferdam 10 and means 20 are diagrammatically illustrated as block 40. Weights 24 and frame 22 are diagrammatically illustrated as block 42. Also, shown are lifting eyes 26. FIG. 2a illustrates the forces acting when cofferdam 10 is stationary positioned against the underwater surface and the water expelled. Force L is a lifting force exerted along cables 28. Force R is a reaction force exerted on block 40 by the underwater surface. Force W is a force exerted by the in-water weight of blocks 40 and 42. Angle a is the angle between the vertical and cables 28. Distance D1 is the horizontal distance from lifting eye 26 to the center of gravity of block 42. Distance D2 is the vertical distance from lifting eye 26 to floor 12.

FIG. 2b is a schematic representation of the forces L, R, and W of FIG. 2a.

From basic mechanics, the following relations are taken:

$$L \cos a = W$$

$$L \sin a = R$$

thus,

$$R = W \tan a$$

also,

$$R \cdot D2 = W \cdot D1$$

then,

$$\tan a = D1/D2$$

the pressure holding means 20 against the underwater surface is:

$$P = R/A$$

where,

$$P = \text{sealing pressure}$$

$$A = \text{seal area}$$

Thus, assuming:

$$W = 12,000 \text{ lbs.}$$

$$D1 = 2 \text{ feet}$$

$$D2 = 8 \text{ feet}$$

$$A = 360 \text{ sq. in.}$$

Then,

$$P = (12,000 \text{ lbs}) \times (2 \text{ ft.}) / (8 \text{ ft.}) \times (360 \text{ sq. in.}) = 8$$

psi

It is noted that, if lifting eyes 26 were located in a vertical plane at further horizontal distance from the un-

derwater surface than the center of gravity of block 42, sealing pressure P would be a negative value.

Obviously numerous modifications and variations of the present invention are possible in light of the above teachings. It is therefore to be understood that within the scope of the appended claims the invention may be practiced otherwise than as specifically described herein.

I claim:

1. A water-tight device for permitting periodic repairs to surfaces below a waterline of a body of water comprising:

- a. a water-tight cofferdam having a floor, a rear wall, and two side walls, said two side walls and said floor having edges for abutting against said underwater object to be repaired;
- b. said cofferdam including means for effecting a water-tight seal between said cofferdam and said submerged object, said means being attached to edges of said two side wall and said floor for abutting against said underwater object to be repaired, said cofferdam having a center of gravity, said rear wall being on one side of said center of gravity and said means for effecting a water-tight seal being on the other side of said center of gravity;
- c. a plurality of weights;
- d. means for supporting said weights attached to said cofferdam, said means and said weights having a center of gravity located a horizontal distance from said center of gravity of said cofferdam in a direction away from the surface of the underwater object to be repaired and below the center of gravity of said cofferdam; and
- e. means for supporting said cofferdam, said plurality of weights, and said means for supporting said weights attached to the water tight device above the center of gravity of said cofferdam, and a horizontal distance from the center of gravity of said weight of said means for supporting said weights toward the surface of the underwater object to be repaired.

2. The device of claim 1 wherein said means for supporting said weights comprises:

- a frame conforming to the contour of said cofferdam whereby said cofferdam is further strengthened.

3. The device of claim 1 wherein said means for supporting said cofferdam, said plurality of weights, and said means for supporting said weights comprises:

- a. a plurality of lifting eyes attached to said water-tight device;
- b. a plurality of flexible cables, each having a first and a second end, each said first end being attached to one of said plurality of lifting eyes; and
- c. means for raising and lowering said device being attached to said second ends of said plurality of flexible cables.

4. The device of claim 3 wherein said plurality of lifting eyes are located in a vertical plane that passes through the center of gravity of said cofferdam.

5. A method for positioning a cofferdam for permitting periodic repairs to objects below the waterline of a body of water comprising:

- a. connecting a plurality of weights to said cofferdam such that the center of gravity of said weights is below the center of gravity of said cofferdam and between the center of gravity of said cofferdam and said rear wall thereof;

5

- b. lowering said cofferdam into the water adjacent said underwater object to be repaired;
- c. abutting said cofferdam against said underwater object to be repaired;
- d. effecting a water-tight seal between said cofferdam and said underwater object to be repaired; and
- e. expelling the water from inside said cofferdam.

6

- 6.** The method of claim 5 wherein said step of connecting comprises:
- a. attaching a means for supporting said plurality of weights to said cofferdam; and
 - b. placing said plurality of weights on said support means.

* * * * *

10

15

20

25

30

35

40

45

50

55

60

65