



(22) Date de dépôt/Filing Date: 2010/04/19
 (41) Mise à la disp. pub./Open to Public Insp.: 2010/10/28
 (45) Date de délivrance/Issue Date: 2011/04/12
 (30) Priorités/Priorities: 2009/07/20 (US61/266,497);
 2009/10/16 (CA2,686,003); 2010/03/18 (US12/726,940)

(51) Cl.Int./Int.Cl. *B65B 11/00* (2006.01),
B05D 1/32 (2006.01)
 (72) Inventeurs/Inventors:
 VAN DEN BERGHE, GARRY CYRILLE ALFRED, CA;
 AMBORSKY, ROBERT, CA
 (73) Propriétaire/Owner:
 VAN DEN BERGHE, GARRY CYRILLE ALFRED, CA
 (74) Agent: BATTISON WILLIAMS DUPUIS

(54) Titre : METHODE D'EMBALLAGE D'UN OBJET A L'AIDE D'UNE PELLICULE ET RUBAN POUR DECOUPER CETTE DERNIERE

(54) Title: WRAPPING AN OBJECT WITH A FILM USING A TAPE FOR CUTTING THE FILM

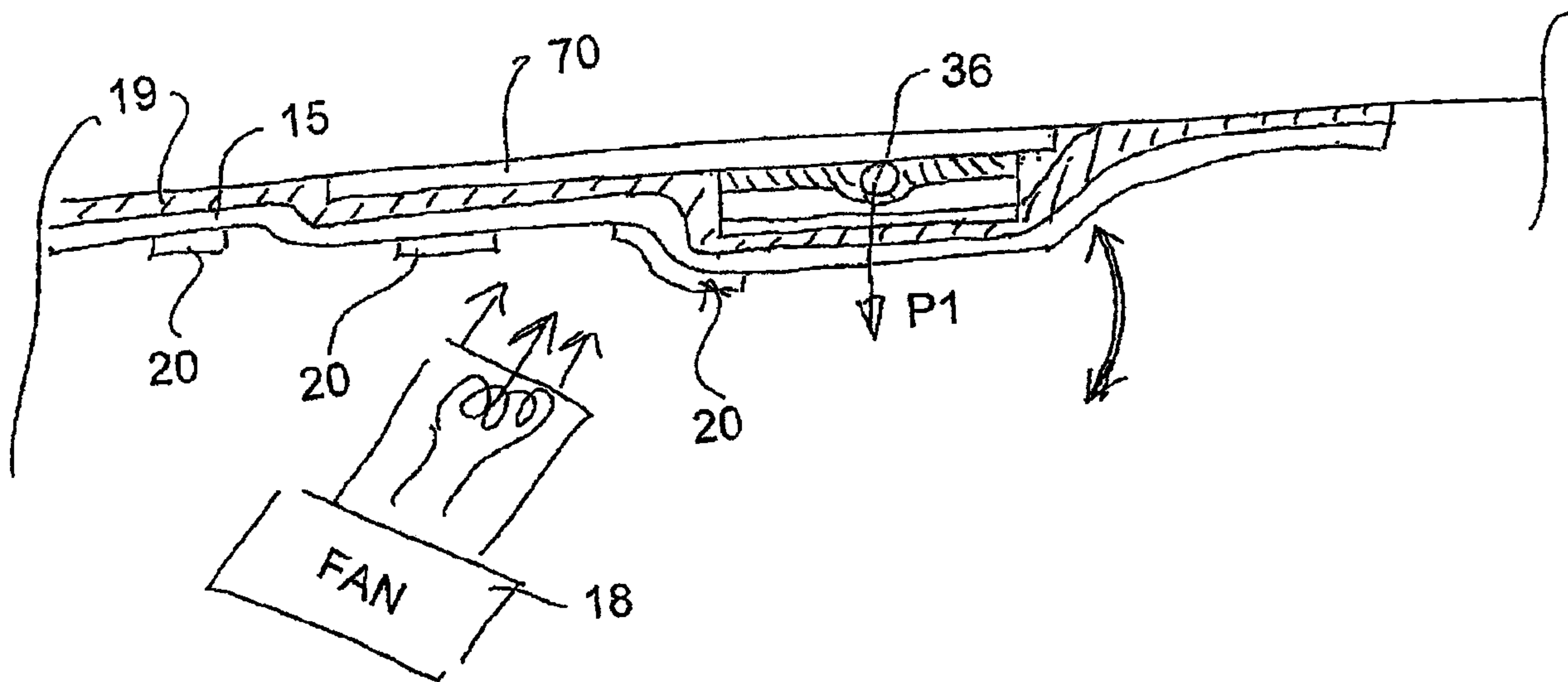

(57) Abrégé/Abstract:

A vehicle is wrapped by a printed adhesive film where the film is also applied over doors and other areas intended not to be covered. The film is cut at the door edge and over the area by adhesively attaching a tape having a release coating on the front surface and carrying a filament along a center of the front side. The printed film is applied over the door, the area not to be covered and the tapes and is cut along the door edge and around the area by pulling the filament from the tape so that a strip of the film at the door edge and the film over the area can be removed. The film can be stretched and pulled away from the tape for reapplying for proper fit.

ABSTRACT

A vehicle is wrapped by a printed adhesive film where the film is also applied over doors and other areas intended not to be covered. The film is cut at the door edge and over the area by adhesively attaching a tape having a release coating on the front surface and carrying a filament along a center of the front side. The printed film is applied over the door, the area not to be covered and the tapes and is cut along the door edge and around the area by pulling the filament from the tape so that a strip of the film at the door edge and the film over the area can be removed. The film can be stretched and pulled away from the tape for reapplying for proper fit.

WRAPPING AN OBJECT WITH A FILM USING A TAPE FOR CUTTING THE FILM

This invention relates to a method of wrapping an object such as a vehicle with a film.

BACKGROUND OF THE INVENTION

5 Popular customization of vehicles in some cases involves the application of an adhesive film carrying printed graphics to the exterior surface of the vehicle. Such a film is readily available for example from 3M and is provided in large sheets carrying a pressure sensitive adhesive covered by a release layer allowing the sheet to be printed with the required graphics and applied to the vehicle.

10 One issue which remains a difficulty is that of cutting the film at required locations so that the film terminates at the edge of a panel or at any other required location on the vehicle.

US patent no: 7,014,900 issued March 21, 2006 and other related patents of Langeman provide an arrangement for cutting a polymer coating which is
15 applied to a surface and cured. The arrangement provides a tape with a filament enveloped in a wrapped portion of the tape where the filament is pulled through the coating to effect a cutting action. However this is not suitable for film of the above type for a number of reasons and has never been used with film.

US patent no: 4,255,469 (Mcginness) issued March 10, 1981 to
20 Hughes Aircraft provides a tape with an attached filament which is used to mask and cut a moisture proof coating applied to circuit boards where certain parts of the board must be masked to remain clear of the coating. The tape is PTFE (Teflon) or

PET (Mylar) and the filament is nylon. This tape is used in very small straight pieces to cover edges of circuit boards and is not suitable for cutting film of the above type for a number of reasons.

US patent no: 2,005,665 (Saignier) issued June 18, 1935 provides a
5 paper tape with an enclosed filament which is attached to boxes and used as a tear strip for tearing open a tear line on the box. Again this tape is used in very small straight pieces and is not suitable for cutting film of the above type for a number of reasons.

SUMMARY OF THE INVENTION

10 It is one object of the invention to provide a method of wrapping an object such as a vehicle with a printed film which reduces the need for using a knife to cut the film when applied which can cause damage to the object.

According to one aspect of the invention there is provided a method for wrapping a surface of an object with a film carrying a pressure sensitive adhesive on
15 one surface by which the film is to be attached to the object, the method comprising:

providing a tape having a front surface, a rear surface, a first longitudinal side edge and a second longitudinal side edge;

the tape having an adhesive on the rear surface for attachment to the object, the adhesive having the characteristic that the tape can be pulled from the
20 surface of the object without leaving an adhesive residue and without damaging the surface;

3

the front surface of the tape being free from adhesive and having a release characteristic relative to the pressure sensitive adhesive on the film such that the pressure sensitive adhesive on the film can be contacted onto the front surface of the tape and pulled away for repositioning;

5 the tape having at least one filament attached thereto;

applying a length of the tape to surface of the object so as to be attached thereto by the adhesive thereon;

10 positioning the film onto the surface of the object and over the tape such that the film is attached by the pressure sensitive adhesive to the surface of the object, with the release characteristic of the front surface of the tape allowing repositioning of the film;

pulling the filament from the tape through that part of the film over the tape so as to cut the film and to form a cut edge of the film;

removing the tape from the surface;

15 and attaching the cut edge to the object.

Preferably the tape is extensible so as to allow bending to at least one side by extension along the opposite side.

20 Preferably the filament is spaced from both side edges to allow bending in both directions. However the filament can be located at or adjacent one edge and other techniques used to effect bending away from the edge with the filament.

Preferably the filament is less extendible than the tape.

Preferably the filament is carried in or on the adhesive on the rear surface. In this case, the adhesive is arranged to hold the filament in place on the tape during bending of the tape while the tape is applied to the surface and while the filament is being pulled to effect the cutting of the film. In this case, the filament
5 when carried on the adhesive has a coating material compatible with the adhesive for generating an improved adhesion between the filament and the adhesive.

In an alternative arrangement, the adhesive is applied onto the substrate over the filament to hold the filament against the surface of the substrate.

Preferably the filament is spaced from the first and second side edges
10 and the tape has a width arranged such that the filament tears through the tape along the length of the tape, when pulled to cut the film, rather than pulling from one side edge of the tape. In this case the tearing of the tape leaves a portion of the tape along the first side edge underneath the edge of the film which is removed after the film is cut and the edge laid flat on the surface. In this case, preferably the tape
15 is colored to visually distinguish the portion of the tape from the film.

In some cases a primer is applied to the surface at least underneath the tape for increased attachment of the edge of the film to the surface and the adhesive of the tape preferably has the characteristic that the tape can be pulled from the primer on the surface of the object without leaving a residue of the adhesive
20 and without damaging the primer surface.

Preferably the tape is formed of a plastics material allowing stretch of the tape greater than that of the filament. Preferably the tape is formed of a

5

Copolymer plastic film. Preferably the pressure sensitive adhesive on the tape is rubber based as this can provide the required properties of adhesion and subsequent removal of the tape.

5 Preferably the tape carries a release coating on the front surface or has base material properties having release characteristics relative to the pressure sensitive adhesive on the film such that the pressure sensitive adhesive on the film can be contacted onto the front surface of the tape and pulled away for repositioning without dislodging the tape from the object.

10 In accordance with another feature the tape may comprise a laminate of a first substrate carrying the adhesive on a rear surface thereof and a second substrate carrying a release coating on a front surface thereof with the filament located between the first and second substrates.

15 In many cases the object includes a hinged panel which can move from a closed position in which an edge of the panel abuts an adjacent edge portion of the object and the method includes:

applying a single length of the tape to the panel along an edge of the panel so that the tape bridges between the edge of the panel and the adjacent edge portion of the object so as to be attached to both;

20 applying the film over the panel and the object at the edge of the panel so as to wrap the object and apply the pattern to the object with the film being attached to the panel and the object by the adhesive;

6

pulling said at least one filament of the single length of tape from the tape so as to cut the film along a line to form two cut edges of the film;

removing any remaining portions of the tape from the edge of the panel and from the edge portion of the object;

5 and attaching the cut edges of the film to the object.

Preferably in this case the tape is located such that the filament is positioned between the edge of the panel and the edge portion of the object.

Preferably in this case the tape is located such that the filament is spaced from the edge of panel and the cut edge of the film on the panel is wrapped
10 around the edge of the panel and attached to a back surface of the panel.

Preferably in this case there is provided a visibly distinct colored stripe along the tape identifying the position of the filament so as to assist in locating the filament at a position between the edge of the panel and the edge portion of the object.

15 Preferably in this case there is provided a visibly distinct colored stripe along a center line of the tape.

Said at least one filament can comprise a single filament located between the two edges. This arrangement cuts between the edges or adjacent one of the edges but in all cases will leave at least one and generally two edge strips of
20 the sheet to be wrapped around the edges of the vehicle body.

As an alternative the tape can use two side by side parallel filaments. In this arrangement a first one of the filaments is located at or adjacent an edge of

7

the panel and a second one of the filaments is located at or adjacent the adjacent edge portion of the object. This acts to reduce or eliminate a portion of the sheet which is left hanging beyond the edge of the panel or body.

Preferably the object includes a surface to be wrapped with an area
5 within the surface on which the object is not to be wrapped and the method includes:

applying a length of the tape to the surface so as to surround the area with ends of the length substantially butting;

applying the film over the surface including the area so as to wrap the object and apply the pattern to the object with the film being attached to the surface
10 and the object by the adhesive;

pulling the filament of the length of tape from the tape so as to cut the film around the area;

removing a remaining portion of the length of the tape from the surface;

15 and removing a portion of the film over the area.

The method can include printing onto a second opposed surface of the film a pattern to be wrapped onto the object so as to apply the pattern around a part of the object and over the panel.

The method can be used to apply various types of film such as vinyl to
20 vehicles. This can include large sheets or panels which are used to wrap or can include stripe packages that also require cutting. Some vehicles have reflective vinyl striping down both sides, so the stripe must be cut around the wheel wells, door

handles and the like. Pinstripes on cars, trucks etc, also require cutting and again this application would alleviate the use of a knife. All applications can be done using various types of vinyl, perhaps printed or unprinted.

The tape may include a substrate with the adhesive applied to one
5 surface of the substrate, or the tape may comprise simply an adhesive material with the filament attached thereto or embedded therein.

The filament can be formed of any suitable material which has sufficient strength to carry out the cutting action when pulled without breaking and a sufficient cutting action to effect cutting and not tearing the film. Metal wire is
10 typically suitable. Other materials such as carbon fiber or Kevlar fiber can be used. UHMWPE (ultra high molecular weight polyethylene) synthetic fiber is preferred.

For trimming abrupt edges of the adhesive coated film preferably the tape has a width less than 0.25 inches so that the bare piece or strip at the edge of the panel and at the edge of the adjacent portion is as narrow as possible. For
15 trimming between hinged panels so as to form a bridge across the gap between the panel and adjacent surface preferably the tape has a width of 0.5 inches.

The absence of adhesive on the front surface of the tape can be used to allow the film position to be adjusted on the panel and on the object so that it is properly placed and located without creases or folds or bubbles while aligning
20 printed images from different sheets as required. Thus the pressure sensitive adhesive on the film itself is used to attach the film to all locations and the release

coating is of a character that the film can be pulled back and re-located when required without dislodging the tape from the object.

Films of this type are available with a release layer from suppliers such as 3M and can be printed with the pattern at the place of application using designs
5 supplied by a customer.

The object is typically a vehicle or boat or other transportation device including automobiles, vans, buses and the like. In this case the panel is typically a door or trunk lid.

The area to be left uncovered can be any area of a surface of the
10 object such as a door handle, gas filler cap or the like. In this case the whole surface of the vehicle or other object is to be covered but includes such areas which cannot be covered without interfering with the operation.

However other objects can be covered where the problem of doors or other panels and the problem of areas to be left uncovered is to be resolved using
15 the above invention. The film typically wraps around at least a side of the vehicle where the hinged panel is a door and around a rear of the vehicle where a second hinged panel is provided and covered using the invention.

According to a second aspect of the invention there is provided a tape comprising:

20 a tape body having a front surface, a rear surface, a first longitudinal side edge and a second longitudinal side edge;

10

the tape body having an adhesive on the rear surface for attachment to the object, the adhesive having the characteristic that the tape can be pulled from the surface of the object without leaving an adhesive residue and without damaging the surface;

5 the front surface of the tape being free from adhesive and having a release characteristic relative to pressure sensitive adhesive on a film such that the film's pressure sensitive adhesive can be contacted onto the front surface of the tape and pulled away for repositioning of the film without dislodging the tape from the object;

10 the tape having a filament attached thereto such that the filament can be pulled from the tape through that part of the film over the tape so as to cut the film and to form a cut edge of the film.

According to a third aspect of the invention there is provided a tape as defined above in combination with the film for which it is designed to be used.

15 BRIEF DESCRIPTION OF THE DRAWINGS

One embodiment of the invention will now be described in conjunction with the accompanying drawings in which:

Figures 1 to 4 show cross sectional views through four embodiments of tape for use in the present invention.

20 Figure 5 is a cross sectional view through a surface of an object showing the tape and film applied during a first step in the method.

Figure 6 is a cross sectional view through the surface and the tape and

film with the filament of the tape pulled to effect cutting of the film.

Figure 7 is a cross sectional view through the surface and the film with the film cut and the last portion of tape being removed.

Figure 8 is a cross sectional view through the object at a junction
5 between a panel such as a door of the vehicle and the adjacent surface of the vehicle showing the tape and film applied for the method.

Figure 8A is a cross sectional view through the object at a junction
between a panel such as a door of the vehicle and the adjacent surface of the vehicle showing an alternative arrangement of the tape and film applied for a
10 modification of the method with the tape carrying a single filament to cut between the edges.

Figure 8B is a cross sectional view of the same components as Figure 8A after the filament has been used to cut the film and after the tape portions have been removed.

Figure 8C is a cross sectional view, similar to that of Figure 8A,
15 through the object at a junction between a panel such as a door of the vehicle and the adjacent surface of the vehicle showing a further alternative arrangement of the tape and film applied for a modification of the method with the tape carrying a two parallel side by side filaments to cut at or adjacent the edges.

Figure 9 is a front elevational view of a surface of the vehicle showing
20 an area not to be covered by the film.

Figure 10 is a cross sectional view along the lines 10-10 of Figure 9.

12

Figures 11, 12 and 13 show various views of a vehicle to be wrapped with a printed film showing door and other panels to be opened and showing areas not to be covered by the film.

In the drawings like characters of reference indicate corresponding parts in the different figures.

DETAILED DESCRIPTION

In Figure 11 is shown a vehicle 10 such as a panel van, including a side panel 11 including a door 13 and a rear panel 12 including hinged panel 14 in the form of a pair of rear doors 14A and 14B.

It is intended that a film 15 should be wrapped around the vehicles to cover the sides 11 and the rear 12. The film can be supplied as a single sheet but typically will be formed in smaller sheets which are butted edge to edge or slightly overlapping to cover as much of the vehicle as is required. Each sheet or the whole sheet is printed with a custom selected pattern to be applied to the vehicle, such as a company logo or the like as required by the vehicle user.

The vehicle includes a number of hinged panels such as doors, trunk lid and hood which can move from a closed position in which an edge 16 of the panel abuts an adjacent edge portion 17 of the vehicle.

The film 15 typically of vinyl is printed with pattern 20 on the front surface and carries an adhesive 19 on the rear surface. The front surface with pattern is typically covered, using a lamination process, by a clear protective vinyl

film. The pattern is arranged to be wrapped onto the vehicle so as to apply the pattern around a part of the vehicle and over the panel.

Such films are available from 3M and are widely used for this purpose. It is supplied with a release layer (not shown) which can be peeled away to expose
5 the pressure sensitive adhesive for attachment to the vehicle.

Typically as the sheet is supplied in flat form and the vehicle surface is extensively contoured, it is necessary to pull and stretch the film to fit the surface. This typically includes, in extreme locations, the application of heat from a heat gun to the sheet 18 and generally includes the repeated steps of pulling the sheet,
10 applying it temporarily over the surface, removing the sheet for further pulling and reapplying the sheet until it is applied in a contour fit condition against the vehicle with no bubbles.

In order to effect cutting of the film at the edges 16 and 17 there is provided a tape 30 shown in Figures 1 to 4 having a front surface 31, a rear surface
15 32, a first longitudinal side edge 33 and a second longitudinal side edge 34. The tape has an adhesive layer 35 on the rear surface 32 for attachment to the vehicle. The tape 30 is free from adhesive on the front surface 31 which instead has a release characteristic allowing it to release from or to repel adhesive such as the adhesive 19 on the sheet 15. This release characteristic is typically provided by an
20 actual coating 31A but can be provided by the characteristics of the substrate itself or by a co-extruded layer on the substrate. The release coating is not intended to be

removed and is not therefore a removable peel away sheet. The tape 30 carries a filament 36.

The filament can be located along one longitudinal side edge 33 or 34 but preferably is located along a line part way or mid way across the tape spaced from both the first and second longitudinal side edges 33, 34.

In Figure 1, the filament is simply applied onto the adhesive layer 35 and is attached thereto. Thus the filament can be simply attached to a pre-existing tape. Typically the thickness of the tape base or substrate and the adhesive is of the order of 0.002 to 0.005 inches and the diameter of the filament is of the order of 0.0025 to 0.010 inches so that the filament stands up from the adhesive and is not buried or implanted in the adhesive material. However the selection of the adhesive and the filament is such that it remains attached during the step of the method up to the pulling of the tape to cut the film.

In Figure 2, the adhesive is applied after the filament is laid on the tape substrate and thus covers over the filament providing an enhanced attachment where required.

In Figure 3, the filament carries a pre-applied adhesive or primer material 36A which co-operates with the adhesive 35 providing an enhanced attachment where required.

In Figure 4 and alternative construction is provided which includes two substrate layers 34A and 34B laminated together by a laminating adhesive 34C with the filament 36 captured between the layers 34A and 34B and thus held in place.

The layer 34A carries on its rear surface the adhesive 35 and the layer 34B carries on its front surface the release coat 31A. The laminating adhesive 34C has to be such that it allows the filament to release from it. The filament could be treated to prevent becoming fixed to the adhesive if say the laminating adhesive was the cross linkable type. This is not an issue if pressure sensitive adhesive is used for the laminating adhesive.

The tape has a width in the range 0.060 to 0.500 inches and is preferably less than 0.25 inches.

The tape is extensible to a degree so as to allow bending to at least one side by extension along the opposite side. Thus the tape can bend to each side through any angle to take up a minimum inside radius of curvature of the order of 0.157 inches. This allows it to be bent or wrapped around elements on the vehicle such as door handles and other items previously described while the tape remains flat against the vehicle surface and attached to the vehicle surface by its layer of adhesive.

As shown the filament is spaced from both side edges to allow bending in both directions. As the filament is located in the middle as shown, the tape is symmetrical and will bend equally in each direction. However the filament can be offset to one side or can be at one edge. In this case the tape can be arranged so that it is applied easily with curvature only in one direction with the filament always on the inside of the curve. With this same configuration, a reverse curve, with the filament on the outside of the curve, can be done by making partial cuts at spaced

positions at right angles to its length along the inside edge to allow the edge to be compressed to form the inside curve. Typically the filament is less extendible than the tape since longitudinal extension of the filament in the longitudinal direction is undesirable during the pulling action.

5 The adhesive thus acts to hold the filament in place on the tape during bending of the tape while the tape is applied to the surface and while the filament is being pulled to effect the cutting of the film.

 The tape is formed of a plastics or filmic material allowing stretch of the tape greater than that of the filament and preferably the tape is formed of a PVC
10 which has been found to provide the best characteristics of strength, co-operation with film adhesive, elongation and clean cutting of the film.

 The filament is preferably formed of Dyneema® which is a synthetic fiber based on ultra high molecular weight polyethylene and has been found to provide the best characteristics of strength, resistance to elongation and flexibility.
15 However other plastics materials such as monoaxially oriented polypropylene or natural fibers can be used including metal wire.

 In use as shown in Figure 8, a first length 30A of the tape is applied and adhesively attached to the panel such that the second longitudinal side edge 34 is applied substantially along the edge 16 of the panel and the first longitudinal side
20 edge 33 is spaced from the edge 16 of the panel. The filament 36 located mid-way between the edges is also therefore located at a position spaced from the edge 16 of the panel.

17

A second length 30B of the tape is applied and adhesively attached to the panel at the edge 17 such that the second longitudinal side edge 34 is applied substantially along the edge 17 of the panel and the first longitudinal side edge 33 is spaced from the edge 17 of the panel. Again the filament 36 is located spaced from the edge 36.

The film 15 is attached by the adhesive 19 over the panel and the vehicle at the edge of the panel so as to wrap the vehicle and apply the pattern 20 to the vehicle with the film being attached to the vehicle by the adhesive 19.

The cutting of the film cannot be carried out in advance of the application since the film stretches and moves as it is applied in order to take up the contours of the vehicle. In many cases it is necessary to apply the film over certain areas and remove it from that area a number of times in order to take up the required position and shape. In some cases it is necessary to apply heat to the film in order to achieve the necessary stretch to match a particularly difficult contour of the vehicle. Thus in effect the film is tailored to the vehicle shape as it is applied making pre-cutting of edges impossible. The whole intention is to apply the film in as large a sheet as possible so that it is in most cases not suitable to cut up the sheet into small pieces for individual application.

The attachment is completed using the skill of the user to properly apply the film without creases and kinks, where necessary pulling the film back from the vehicle surface and the tape to adjust. When attachment is complete, the filament 36 of the first length from the tape is pulled at P1 (Figures 5 and 6) so as to

18

cut the film at the first length of tape 30A. The filament 36 of the second length from the tape is pulled so as to cut the film at the second length 30B.

The filament 36 is spaced from the first and second side edges 33, 34 and the tape has a width arranged such that the filament tears through the tape 30 along the length of the tape, when pulled to cut the film, rather than pulling from one side edge 33, 34 of the tape. This is shown in Figures 5 and 6 where the filament 36 is pulled out through a tear 30R in the center of the tape 30. This acts to cut the film at the location directly over the tear in the tape as indicated at 18R.

The tearing of the tape leaves a portion 30P of the tape along the first side edge underneath the edge of the film. The tearing of the tape leaves a portion 30Q of the tape along the first side edge underneath the portion 18P of the film which is intended to be removed from the cut edge of the film.

The portion 18P of the film and the portion 30Q of the tape are simply removed as they are freely exposed beyond the cut edge 18R. The portion 30P of the tape is removed as indicated at 68 after the film is cut by lifting the edge of the film as indicated at 69 and by carefully pulling the portion away from the cut edge generally parallel to the surface of the vehicle. After the portion 30P is removed, the edge portion of the film at the cut edge 18R is laid flat on the surface of the vehicle. In order to assist in identifying and locating the portion 30P of the tape to ensure that it is all removed, the tape is preferably brightly colored to visually distinguish the portion of the tape from the film.

In some cases to assist in attaching the edge of the film to the surface, a band of primer 70 is applied to the surface at least underneath the tape for increased attachment of the edge of the film to the surface. The adhesive of the tape has the characteristic that the tape can be pulled from the primer 70 on the surface of the object without leaving a residue of the adhesive and without damaging the surface. It will be appreciated that the primer is designed to ensure an increase in adhesive effect with the adhesive 19 of the film and hence the adhesive 35 of the tape must be arranged such that it does not adhere more effectively to the primer in a manner which would prevent simple removal of the tape portions or would lead to adhesive residue being left on the vehicle surface at the primer.

The release coating 31 on the front surface of the tape 30 has a release characteristic relative to the pressure sensitive adhesive 19 on the film such that the pressure sensitive adhesive on the film can be contacted onto the front surface of the tape and pulled away for repositioning.

As shown in Figures 11 to 13, the vehicle also includes a series of areas which are to be uncovered when the film is applied since the presence of the film would interfere with the operation of the underlying components. This includes door handles 41 and 42, gas filler cap 43 and light housings 44 and number plates 45. In Figures 9 and 10, the technique for exposing these elements is shown where a length 51 of the tape 30 is applied to the surface 52 so as to surround the area 53 with one longitudinal side edge of the length of the tape facing inwardly toward the area 53 and with the second longitudinal side edge 33 facing outwardly away from

20

the area with the filament 35 of the length of the tape between those side edges as described hereinbefore and with ends 54 and 55 of the length coming together. Generally the ends are not butted together, but instead, for example where the area 53 is a gas cover, the ends are overlapped so that there is enough filament available
5 to start a cut by pulling on that filament. Alternatively for example where the area 53 is an indented door handle, the ends can cross over into the area 53 and a cut line can be started by cutting with a knife into an indentation of door handle to find one of those ends.

Again the film is applied over the surface 52 including the area 53 so
10 as to wrap the vehicle and apply the pattern to the vehicle with the film being attached to the surface and the vehicle by the adhesive.

Again the filament 36 of the length 51 is pulled at P6 from the tape so as to cut the film around the area 53. The remaining portions of the length 51 of the tape are removed from the surface taking with it the remaining portion of the film 53A
15 over the area. The release coating also facilitates the smooth release the tape portion during this step. The tape substrate has to be of such strength that it does not break during removal. The edge of the film around the area is flattened down onto the surface after the portion of tape underneath the edge is removed.

The release characteristic of the front side of the tape is critical to the
20 application. Not enough release and the wrap film adhesive will stick to the tape and pull the tape off the automobile during repositioning of the wrap film during normal fitting of the wrap film to the automobile.

The release characteristic can be provided by the character of the tape itself in which the base material can be such (Teflon for example) which has low adhesion with the wrap film adhesive. The surface of the base tape film can also be embossed with a pattern that limits the contact area of the film's adhesive thus providing good release. Alternatively a release coating (silicone etc.) can be added to the front surface of the tape to do the same thing. Most tapes are coated on the front surface so that you can pull the tape off the roll. Electrical tape is unsuitable in that it has little or no release coating because it has to stick to itself when wrapped around a wire.

Plastic film based tape works better than paper based tape to produce a clean cut (like a razor) through the wrap film. Paper based tapes produce jagged cuts noticeable to the eye and touch.

Turning now to Figures 8A and 8B, there is shown an alternative to the method of Figure 8 which discloses the use of two tapes at a junction in the object between a hinged panel which can move from a closed position in which an edge of the panel abuts an adjacent edge portion of the object.

Thus in Figure 8A is shown a cross sectional view through the object at a junction between a panel such as a door of the vehicle and the adjacent surface of the vehicle where there is provided an edge 16 of the panel and an adjacent edge 17 of the object or vehicle. In Figure 8A a single tape 30S is used having the construction shown in Figure 3 so that it includes a filament 36.

Figure 8B shows the same components as those in Figure 8A after the

filament 36 has been used to cut the film 15 and after the remanent tape portions have been removed.

In Figure 8A, the method includes the steps of applying a single length 30S of the tape to the object at the edge of the panel along the edge 16 of the panel so that the tape 30S bridges between the edge 16 of the panel and the adjacent edge portion 17 of the object so as to be attached to both.

For this purpose the tape is typically wider than the tape used in other areas of the object or vehicle so that the tape may be 0.5 inch or even 1.0 inch in width. The tapes therefore may be supplied in a kit of tapes to be used on the vehicle including a sufficient length of the narrower tape for use in places other than the bridging location and a sufficient length of the bridging tape.

The tape is thus securely adhesively attached to the edge 16 and the edge 17 with a single filament 36 located in the space between.

As described previously, the film 15 is applied over the panel and the object at the edge of the panel so as to wrap the object and apply the pattern to the object with the film being attached to the panel and the object by the adhesive. The tape and the film and the application thereof can use the constructions and arrangements described previously which will not be repeated here.

The filament of the single length of tape is pulled from the tape so as to cut the film along a line to form two cut edges of the film.

The remaining portions of the tape are pulled from the edge 16 of the panel and from the edge portion 17 of the object. In the arrangement as shown the

tape is split into two portions by the pulling of the filament one of which remains on each side. However this may not be so if other constructions of tape are used.

At the end of the process as shown in Figure 8B, the cut edges 15X and 15Y of the film are attached to the object.

5 As shown in Figure 8A, the tape is located such that the single filament is positioned between the edge of the panel and the edge portion of the object and spaced from both. This is the preferred arrangement but it will be appreciated that there is little necessity for directly accurate positioning of the filament between the edges so that the filament may wander to one side or the other during the manual
10 application depending on the skill of the user.

To assist the positioning of the tape there is provided a visibly distinct colored stripe 60 along the exposed surface of the tape identifying the position of the filament so as to assist in locating the filament at a position between the edge of the panel and the edge portion of the object. That is the visibly distinct stripe which may
15 be colored is arranged in this embodiment along a center line of the tape.

With the filament located between the edge 16 and 17, the tape is located such that the filament is spaced from the edge 16 of panel and from the edge 17 so that when the filament is pulled this leaves an edge portion 15X and 15Y of the film at the edges 16 and 17 respectively. If the filament is closer to one or the
20 other the width of the cut edge portion on that edge is smaller. However in cases where a cut edge portion remains, this cut edge is wrapped around the edge and adhered to the surface. The wrapping may be sufficient to entirely envelope the

edge and engage the rear surface depending on the size of the gap and the location of the filament. This can be helpful to protect the edge 16 of the panel particularly and to properly locate the cut edge 15X of the film around the edge of the panel to be attached to a back surface of the panel where it is better protected and less
5 visible.

The above arrangement therefore allows users to wrap the film material right to the edge of the door or other panel. The width of the tape is increased so that the tape width can bridge the gap between a door, a hood etc. The film wrap is trimmed as before using the filament but this time $\frac{1}{2}$ the gap width
10 worth of the film material is left after the trim, assuming the accurate location of the filament between the two edges. The excess material is folded around the edge of the door, in this example, thus providing wrap material right to the edge. Another option is to align the printed line, that is the filament, with the edge of the door and trim the wrap film accurately to that edge with no wrap around piece. The excess
15 piece is therefore on the edge 17 and can be laid flat or partly wrapped as required.

As shown in the modification of Figure 8C the tape carries two parallel side by side filaments 36X and 36Y to cut at or adjacent the edges 16 and 17. The single filament of Figure 8A is located between the two edges. This arrangement cuts between the edges or adjacent one of the edges but in all cases will leave at
20 least one and generally two edge strips of the sheet to be wrapped around the edges of the vehicle body.

25

In the alternative of Figure 8C the tape uses two side by side parallel filaments. In this arrangement a first one of the filaments 36X is located at or adjacent an edge 16 of the panel and a second one of the filaments 36Y is located at or adjacent the adjacent edge portion of the object. This acts to reduce or eliminate a portion of the sheet which is left hanging beyond the edge of the panel or body.

The spacing between the filaments is selected so that it is very close to the typical gap width in automobile manufacture. This would typically be of the order of 0.5 inch. Each filament carries out a separate cut with the center portion between the filaments remaining attached to one or both as both are pulled. Each filament is associated with a respective colored strip 60 so as to assist in the user guiding the tape into the required location.

Since various modifications can be made in my invention as herein above described, and many apparently widely different embodiments of same made within the spirit and scope of the claims without departure from such spirit and scope, it is intended that all matter contained in the accompanying specification shall be interpreted as illustrative only and not in a limiting sense.

CLAIMS:

1. A method for wrapping a surface of an object with a film carrying a pressure sensitive adhesive on one surface by which the film is to be attached to the object, the method comprising:

5 providing a tape having a front surface, a rear surface, a first longitudinal side edge and a second longitudinal side edge;

the tape having an adhesive on the rear surface for attachment to the object, the adhesive having the characteristic that the tape can be pulled from the surface of the object without leaving an adhesive residue and without damaging the
10 surface;

the front surface of the tape being free from adhesive and having a release characteristic relative to the pressure sensitive adhesive on the film such that the pressure sensitive adhesive on the film can be contacted onto the front surface of the tape and pulled away for repositioning without dislodging the tape
15 from the object;

the tape having at least one filament attached thereto;

applying a length of the tape to surface of the object so as to be attached thereto by the adhesive thereon;

positioning the film onto the surface of the object and over the tape
20 such that the film is attached by the pressure sensitive adhesive to the surface of the object, with the release characteristic of the front surface of the tape allowing repositioning of the film;

27

pulling the filament from the tape through that part of the film over the tape so as to cut the film and to form a cut edge of the film;

removing the tape from the surface;

and attaching the cut edge to the object.

5 2. The method according to Claim 1 wherein the tape has a width less than 0.25 inches.

3. The method according to Claim 1 or 2 wherein the tape is extensible so as to allow bending to at least one side by extension along the opposite side.

10 4. The method according to Claim 3 wherein the filament is spaced from both side edges to allow bending in both directions.

5. The method according to Claim 3 or 4 wherein the filament is less extendible than the tape.

15 6. The method according to any one of Claims 1 to 5 wherein the filament is carried in or on the adhesive on the rear surface.

7. The method according to Claim 6 wherein the adhesive is arranged to hold the filament in place on the tape during bending of the tape while the tape is applied to the surface and while the filament is being pulled to effect the cutting of the film.

20 8. The method according to Claim 6 or 7 wherein the filament is carried on the adhesive and the filament carries a coating material compatible with

the adhesive for generating an improved adhesion between the filament and the adhesive.

9. The method according to Claim 6 wherein the tape includes a substrate and the adhesive is applied onto the substrate over the filament to hold the filament against the surface of the substrate.

10. The method according to any one of Claims 1 to 9 wherein the filament is spaced from the first and second side edges and the tape has a width arranged such that the filament tears through the tape along the length of the tape, when pulled to cut the film, rather than pulling from one side edge of the tape.

11. The method according to Claim 10 wherein the tearing of the tape leaves a portion of the tape along the first side edge underneath the edge of the film which is removed after the film is cut and the edge laid flat on the surface.

12. The method according to Claim 11 wherein the tape is colored to visually distinguish the portion of the tape from the film.

13. The method according to any one of Claims 1 to 12 wherein a primer is applied to the surface at least underneath the tape for increased attachment of the edge of the film to the surface and wherein the adhesive of the tape has the characteristic that the tape can be pulled from the primer on the surface of the object without leaving a residue of the adhesive and without damaging the surface.

14. The method according to any one of Claims 1 to 13 wherein the tape is formed of a plastics material allowing stretch of the tape greater than that of the filament.

5 15. The method according to any one of Claims 1 to 14 wherein the release characteristic of the front surface of the tape is provided by a release coating on the front surface.

10 16. The method according to any one of Claims 1 to 15 wherein the tape comprises a laminate of a first substrate carrying the adhesive on a rear surface thereof and a second substrate carrying a release coating forming said release characteristic on the front surface thereof with the filament located between the first and second substrates.

17. The method according to any one of Claims 1 to 16 including printing onto a second opposed surface of the film a pattern to be wrapped onto the object so as to apply the pattern around a part of the object and over the surface.

15 18. A method for wrapping a surface of an object with a film carrying a pressure sensitive adhesive on one surface by which the film is to be attached to the object, the method comprising:

providing a tape having a front surface, a rear surface, a first longitudinal side edge and a second longitudinal side edge;

20 the tape having an adhesive on the rear surface for attachment to the object, the adhesive having the characteristic that the tape can be pulled from the

surface of the object without leaving an adhesive residue and without damaging the surface;

the front surface of the tape being free from adhesive and having a release characteristic relative to the pressure sensitive adhesive on the film such that the pressure sensitive adhesive on the film can be contacted onto the front surface of the tape and pulled away for repositioning without dislodging the tape from the object;

the tape having at least one filament attached thereto;

applying a length of the tape to surface of the object so as to be attached thereto by the adhesive thereon;

positioning the film onto the surface of the object and over the tape such that the film is attached by the pressure sensitive adhesive to the surface of the object, with the release characteristic of the front surface of the tape allowing repositioning of the film;

pulling the filament from the tape through that part of the film over the tape so as to cut the film and to form a cut edge of the film;

removing the tape from the surface;

and attaching the cut edge to the object;

wherein the object includes a surface to be wrapped with an area within the surface on which the object is not to be wrapped and wherein the method includes:

applying a length of the tape to the surface so as to surround the area;

31

applying the film over the surface including the area so as to wrap the object and apply the pattern to the object with the film being attached to the surface and the object by the adhesive;

5 pulling the filament of the length of tape from the tape so as to cut the film around the area;

removing a remaining portion of the length of the tape from the surface;

and removing a portion of the film over the area.

19. A method for wrapping a surface of an object with a film carrying
10 a pressure sensitive adhesive on one surface by which the film is to be attached to the object, the method comprising:

providing a tape having a front surface, a rear surface, a first longitudinal side edge and a second longitudinal side edge;

15 the tape having an adhesive on the rear surface for attachment to the object, the adhesive having the characteristic that the tape can be pulled from the surface of the object without leaving an adhesive residue and without damaging the surface;

20 the front surface of the tape being free from adhesive and having a release characteristic relative to the pressure sensitive adhesive on the film such that the pressure sensitive adhesive on the film can be contacted onto the front surface of the tape and pulled away for repositioning without dislodging the tape from the object;

32

the tape having at least one filament attached thereto;

applying a length of the tape to surface of the object so as to be attached thereto by the adhesive thereon;

5 positioning the film onto the surface of the object and over the tape such that the film is attached by the pressure sensitive adhesive to the surface of the object, with the release characteristic of the front surface of the tape allowing re-positioning of the film;

pulling the filament from the tape through that part of the film over the tape so as to cut the film and to form a cut edge of the film;

10 removing the tape from the surface;

and attaching the cut edge to the object;

wherein the object includes a hinged panel which can move from a closed position in which an edge of the panel abuts an adjacent edge portion of the object and wherein the method includes:

15 applying a single length of the tape to the panel along an edge of the panel so that the tape bridges between the edge of the panel and the adjacent edge portion of the object so as to be attached to both;

20 applying the film over the panel and the object at the edge of the panel so as to wrap the object and apply the pattern to the object with the film being attached to the panel and the object by the adhesive;

pulling said at least one filament of the single length of tape from the tape so as to cut the film along a line to form two cut edges of the film;

removing any remaining portions of the tape from the edge of the panel and from the edge portion of the object;

and attaching the cut edges of the film to the object.

20. The method according to Claim 19 wherein the tape is located
5 such that the filament is positioned between the edge of the panel and the edge portion of the object.

21. The method according to Claim 19 or 20 wherein the tape is located such that the filament is spaced from the edge of panel and the cut edge of the film on the panel is wrapped around the edge of the panel.

10 22. The method according to any one of Claims 19 to 21 wherein there is provided a visibly distinct colored stripe along the tape identifying the position of the filament so as to assist in locating the filament at a position between the edge of the panel and the edge portion of the object.

15 23. The method according to Claim 19 wherein there is provided a visibly distinct stripe along a center line of the tape.

24. The method according to any one of Claims 19 to 23 wherein said at least one filament comprises two side by side parallel filaments.

20 25. The method according to Claim 24 wherein a first one of the filaments is located at or adjacent an edge of the panel and a second one of the filaments is located at or adjacent the adjacent edge portion of the object.

26. The method according to any one of Claims 18 to 25 wherein the tape has a width less than 0.25 inches.

34

27. The method according to any one of Claims 18 to 26 wherein the tape is extensible so as to allow bending to at least one side by extension along the opposite side.

28. The method according to Claim 27 wherein the filament is spaced from both side edges to allow bending in both directions.

29. The method according to Claim 27 or 28 wherein the filament is less extendible than the tape.

30. The method according to any one of Claims 18 to 29 wherein the filament is carried in or on the adhesive on the rear surface.

31. The method according to Claim 30 wherein the adhesive is arranged to hold the filament in place on the tape during bending of the tape while the tape is applied to the surface and while the filament is being pulled to effect the cutting of the film.

32. The method according to Claim 30 or 31 wherein the filament is carried on the adhesive and the filament carries a coating material compatible with the adhesive for generating an improved adhesion between the filament and the adhesive.

33. The method according to Claim 30 wherein the tape includes a substrate and the adhesive is applied onto the substrate over the filament to hold the filament against the surface of the substrate.

34. The method according to any one of Claims 18 to 33 wherein the filament is spaced from the first and second side edges and the tape has a width

35

arranged such that the filament tears through the tape along the length of the tape, when pulled to cut the film, rather than pulling from one side edge of the tape.

35. The method according to Claim 34 wherein the tearing of the tape leaves a portion of the tape along the first side edge underneath the edge of the film which is removed after the film is cut and the edge laid flat on the surface.

36. The method according to Claim 35 wherein the tape is colored to visually distinguish the portion of the tape from the film.

37. The method according to any one of Claims 18 to 36 wherein a primer is applied to the surface at least underneath the tape for increased attachment of the edge of the film to the surface and wherein the adhesive of the tape has the characteristic that the tape can be pulled from the primer on the surface of the object without leaving a residue of the adhesive and without damaging the surface.

38. The method according to any one of Claims 18 to 37 wherein the tape is formed of a plastics material allowing stretch of the tape greater than that of the filament.

39. The method according to any one of Claims 18 to 38 wherein the release characteristic of the front surface of the tape is provided by a release coating on the front surface.

40. The method according to any one of Claims 18 to 39 wherein the tape comprises a laminate of a first substrate carrying the adhesive on a rear surface thereof and a second substrate carrying a release coating forming said

36

release characteristic on [a] the front surface thereof with the filament located between the first and second substrates.

41. The method according to any one of Claims 18 to 40 including printing onto a second opposed surface of the film a pattern to be wrapped onto the
5 object so as to apply the pattern around a part of the object and over the surface.

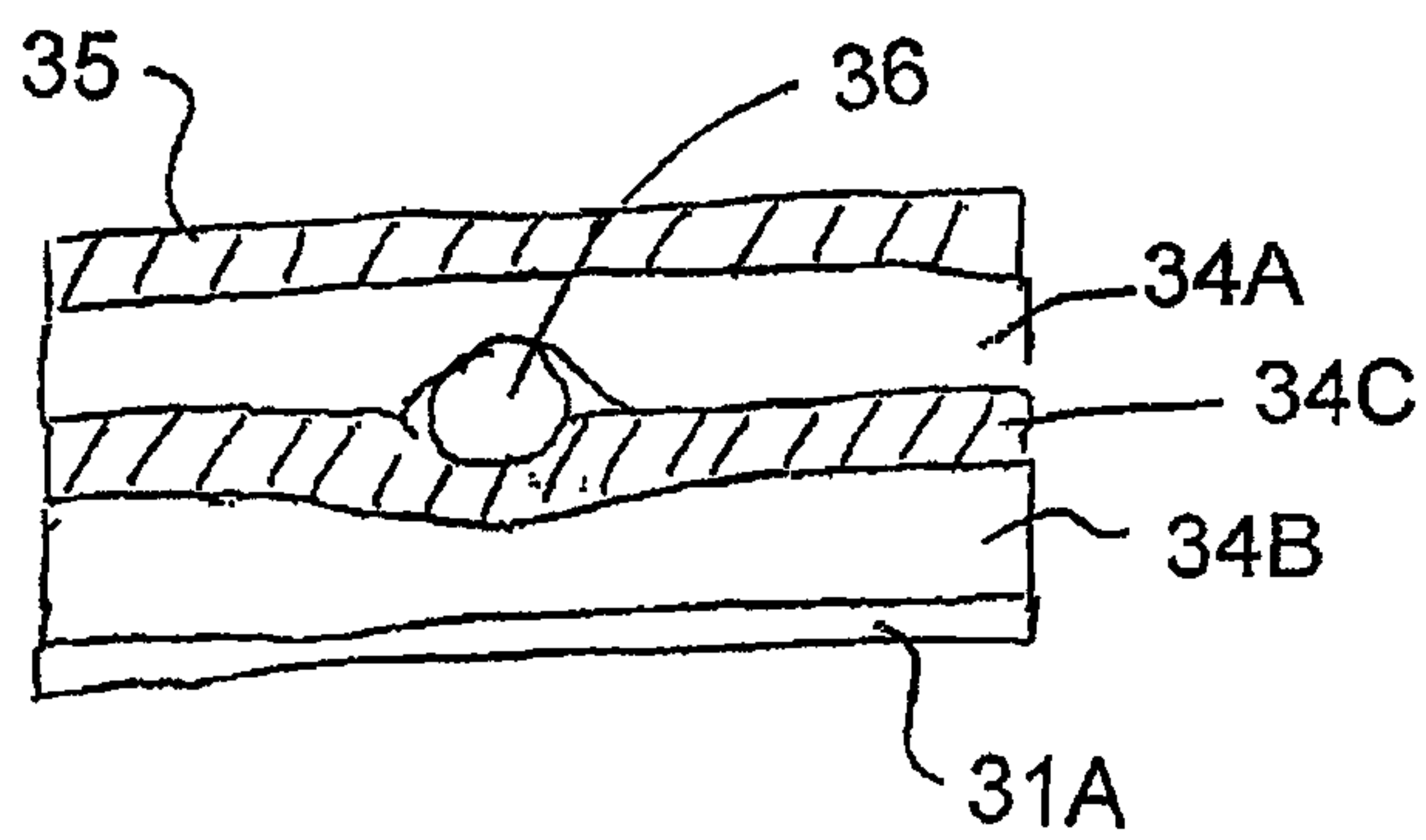
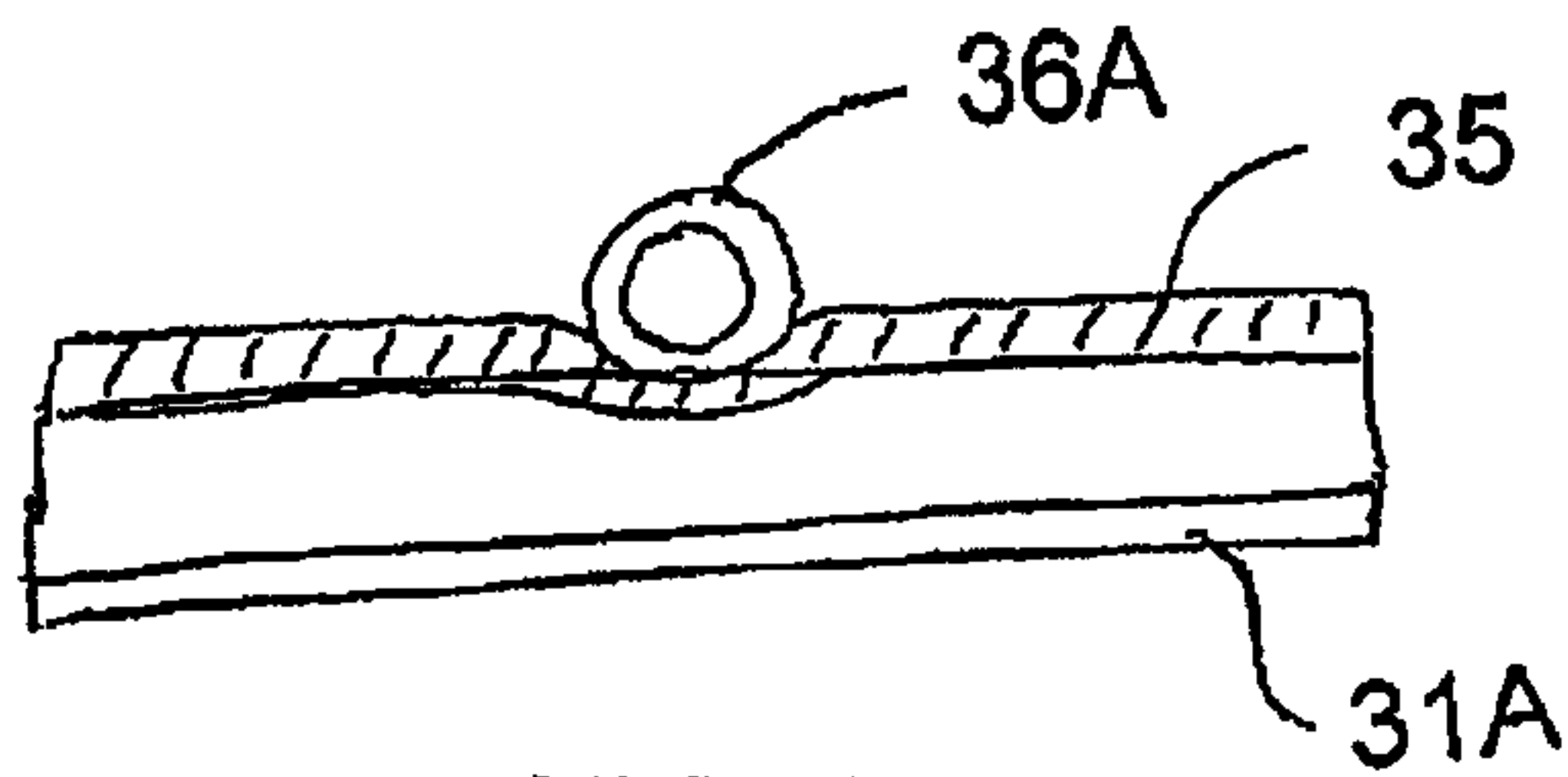
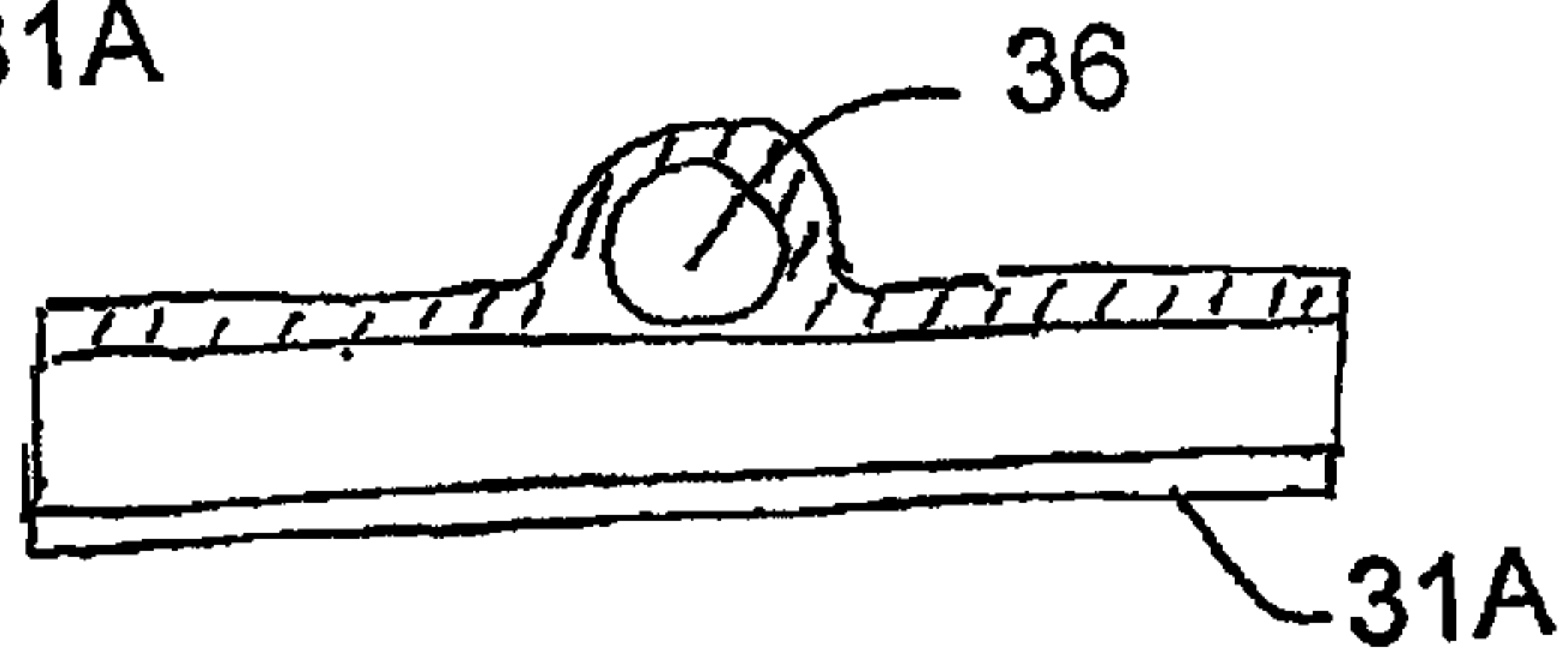
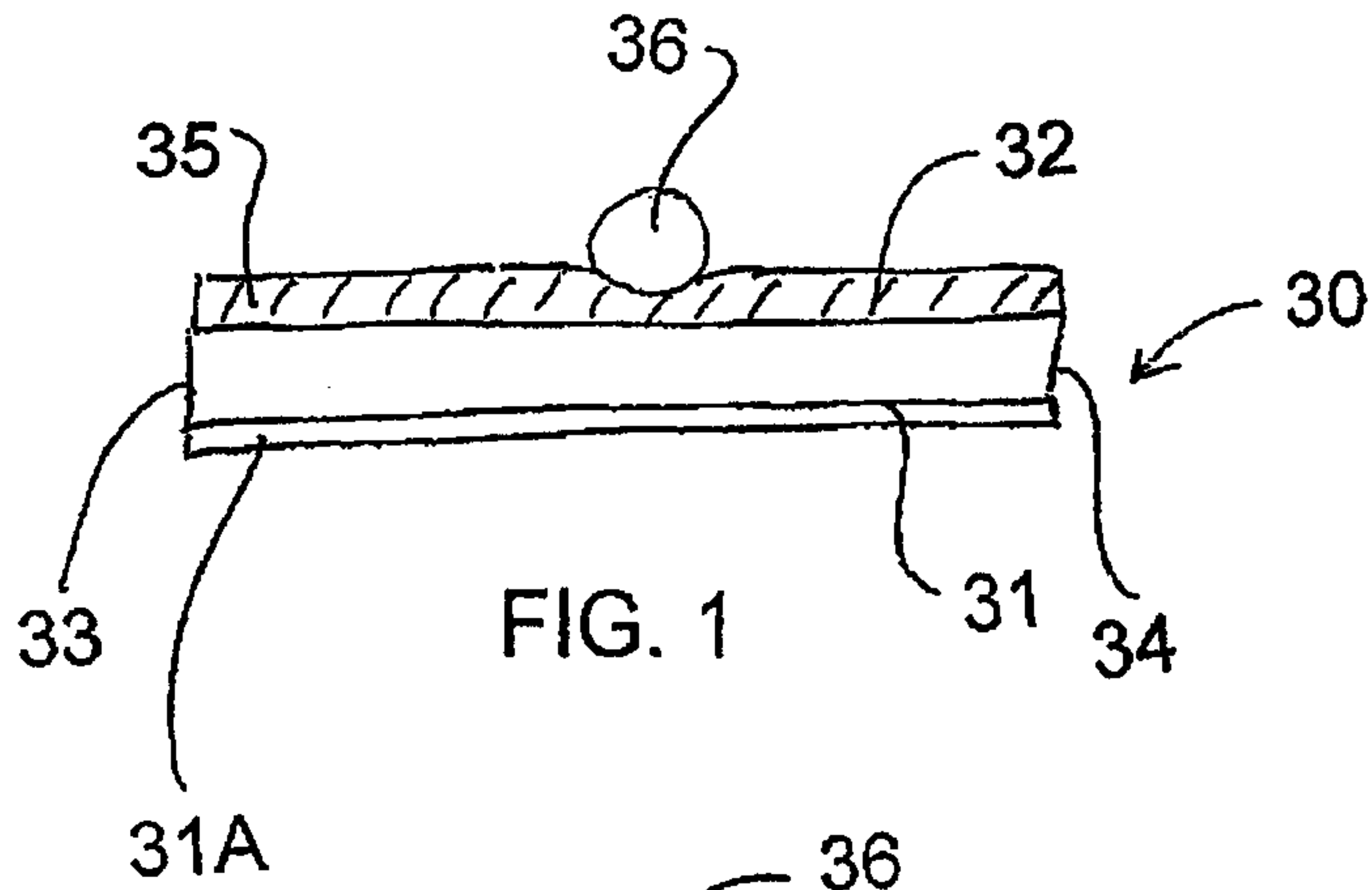

FIG. 5

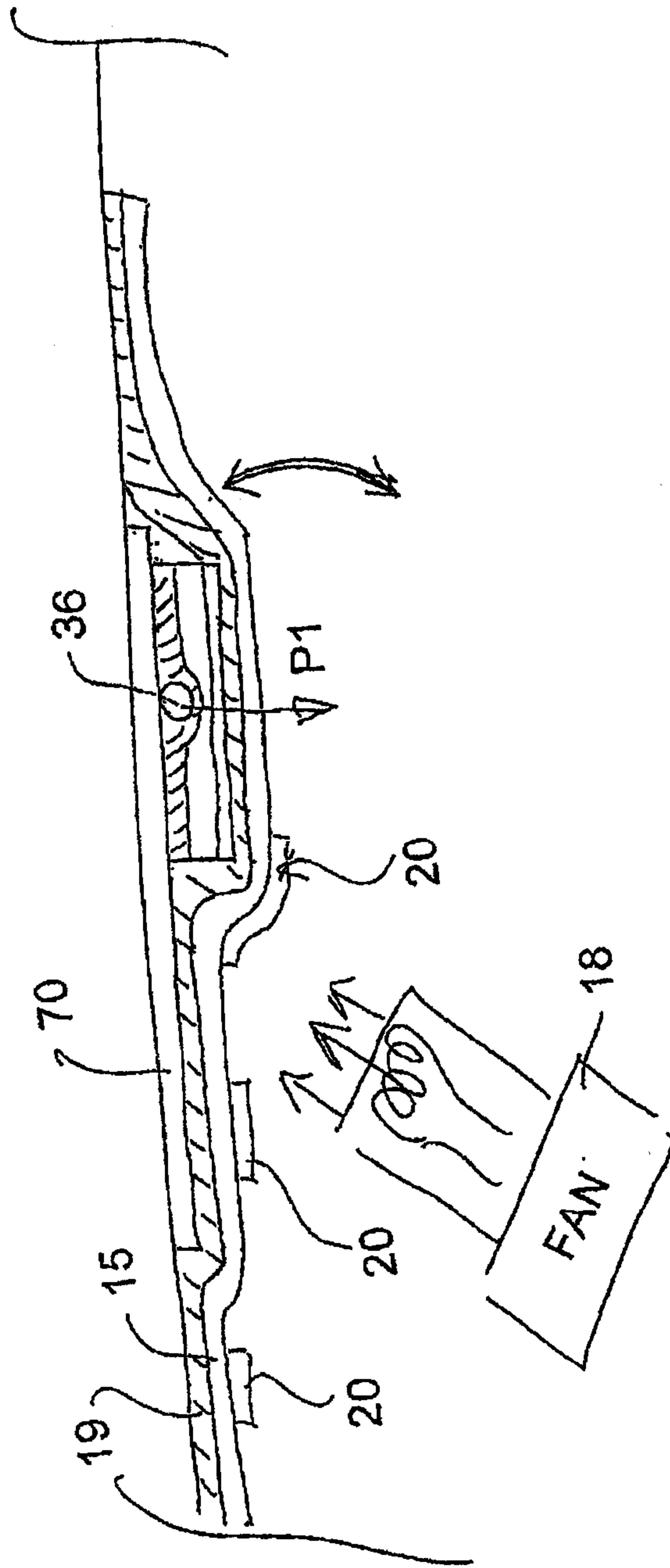

FIG. 6

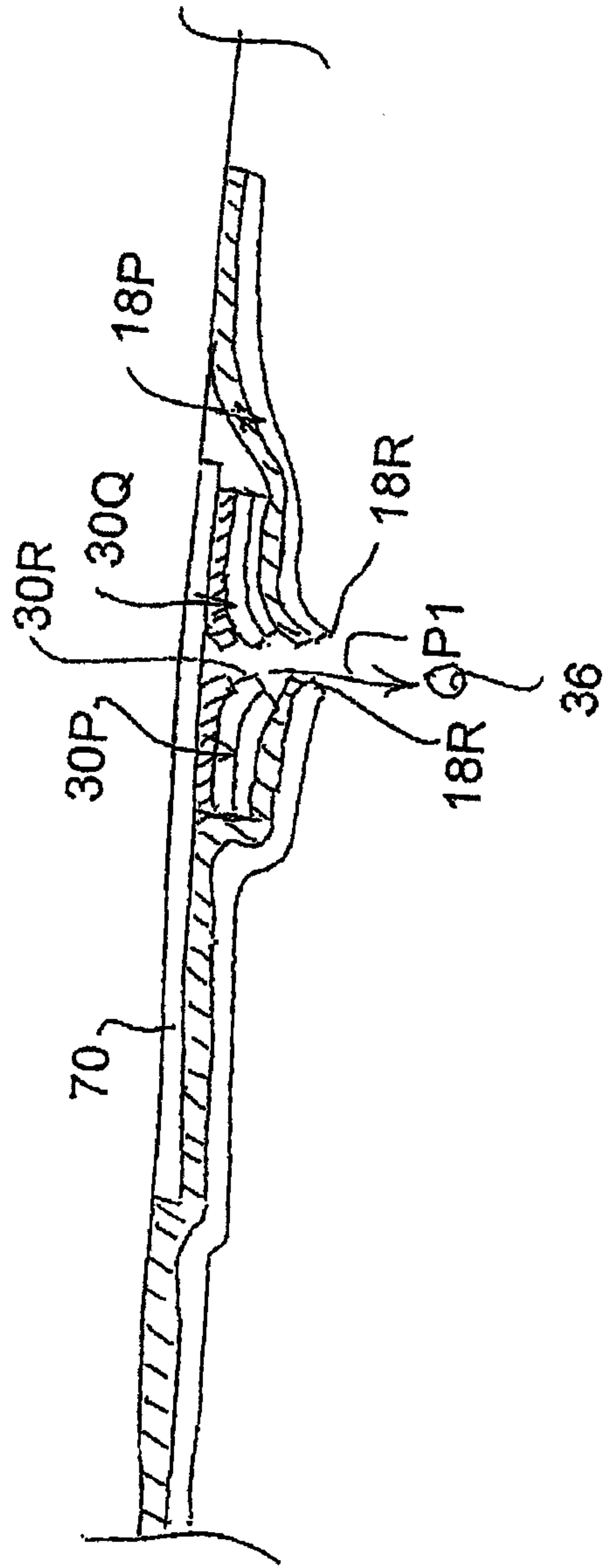
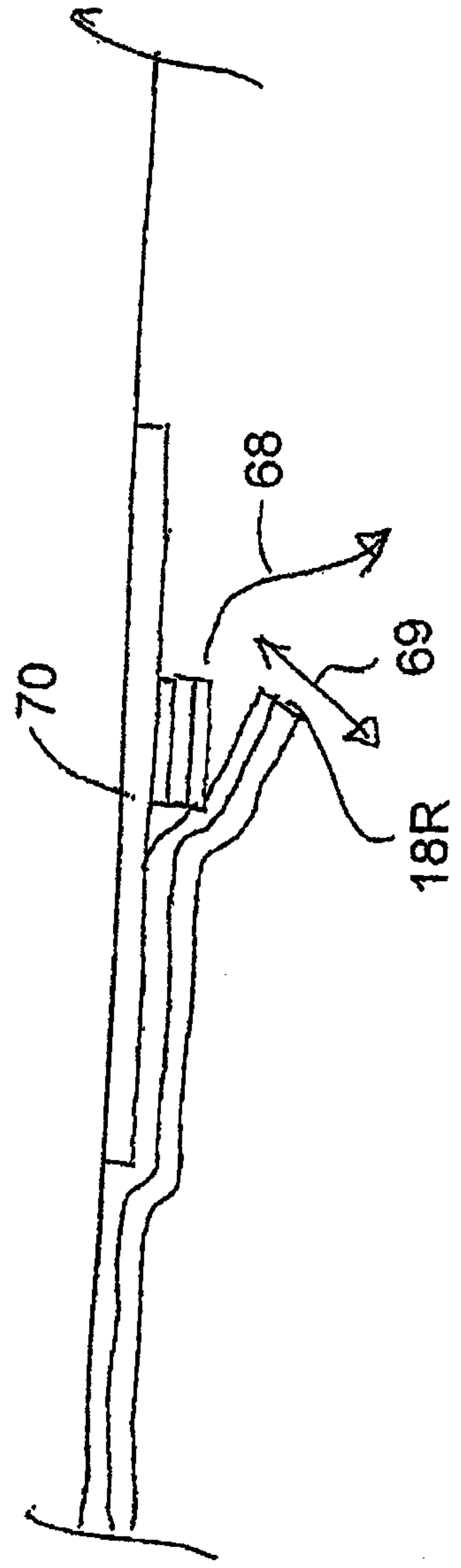

FIG. 7



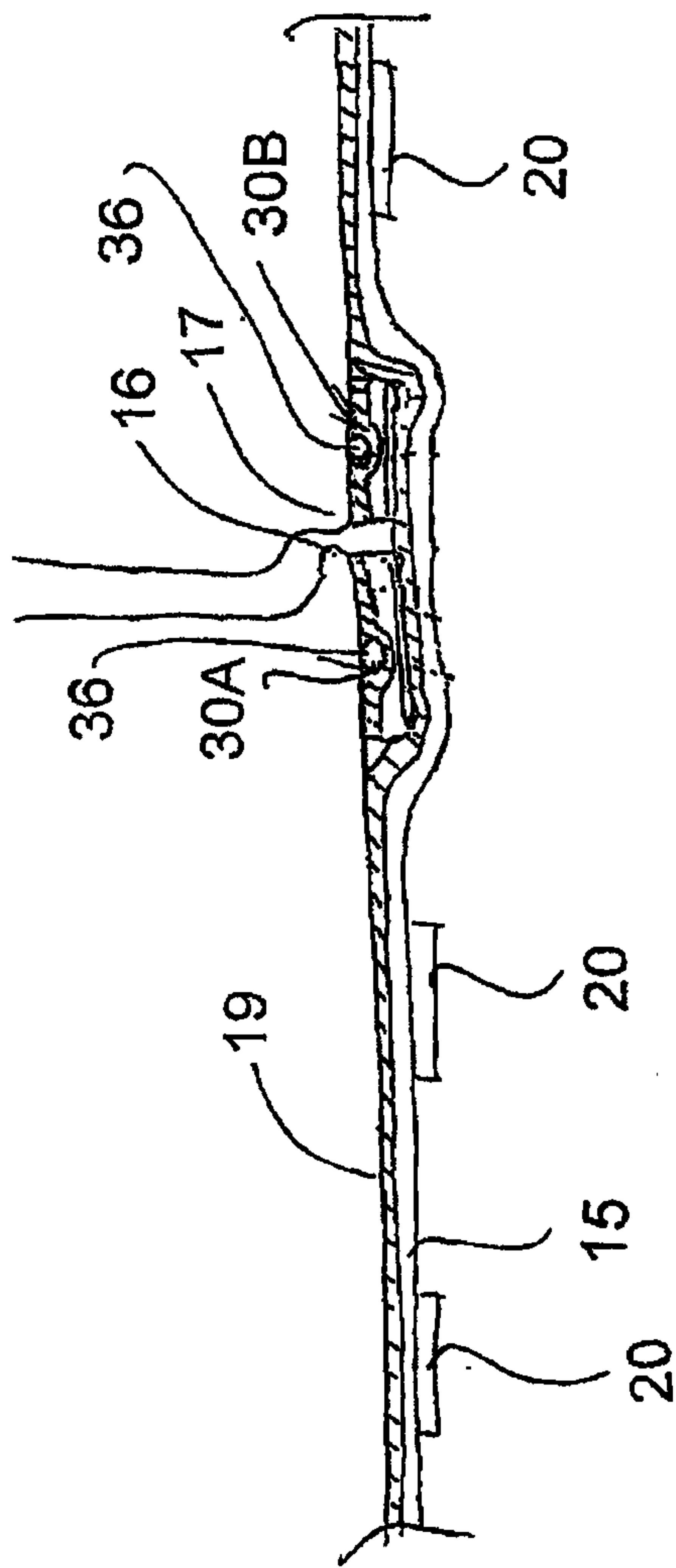

FIG. 8

FIG. 8A

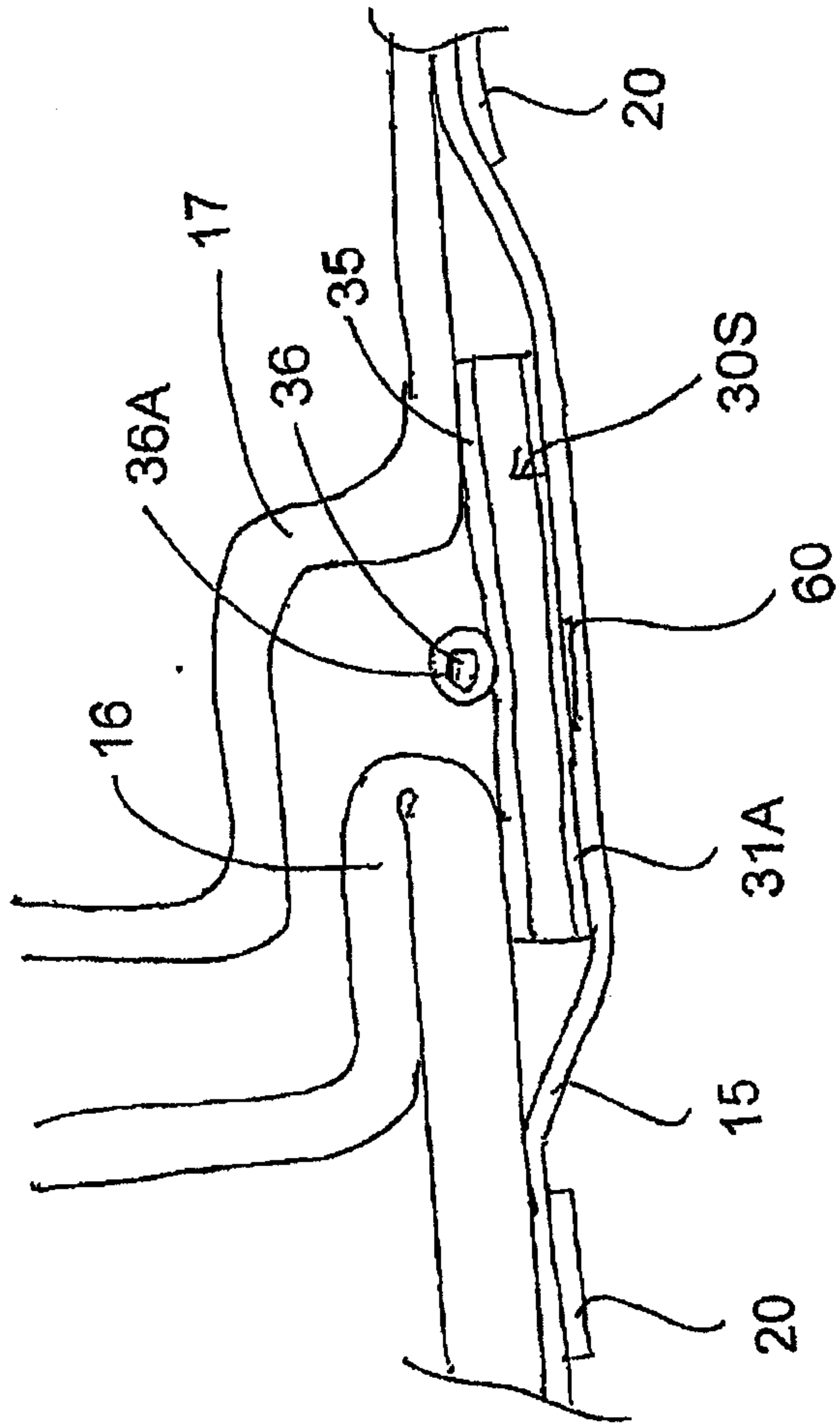

FIG. 8B

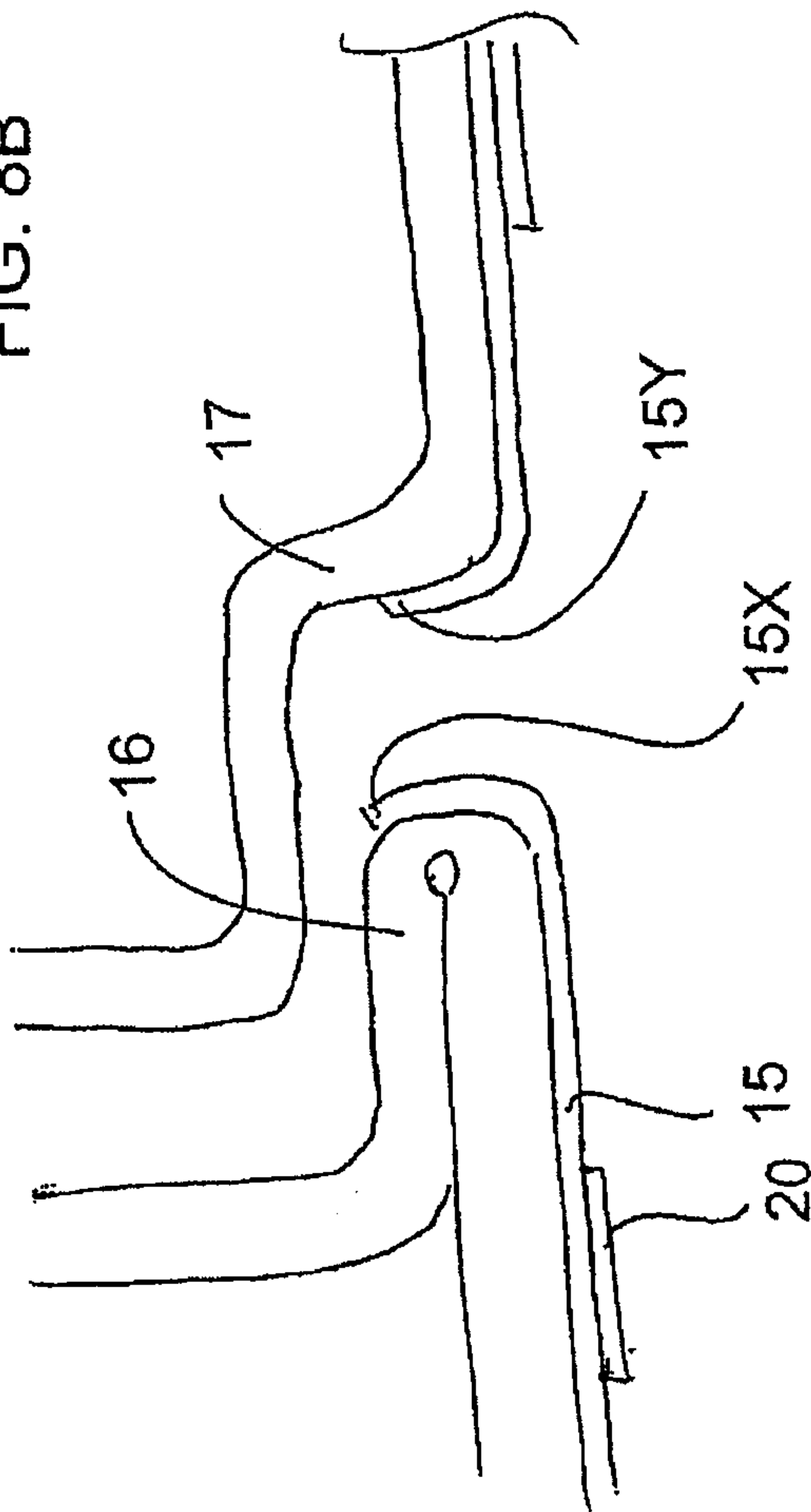
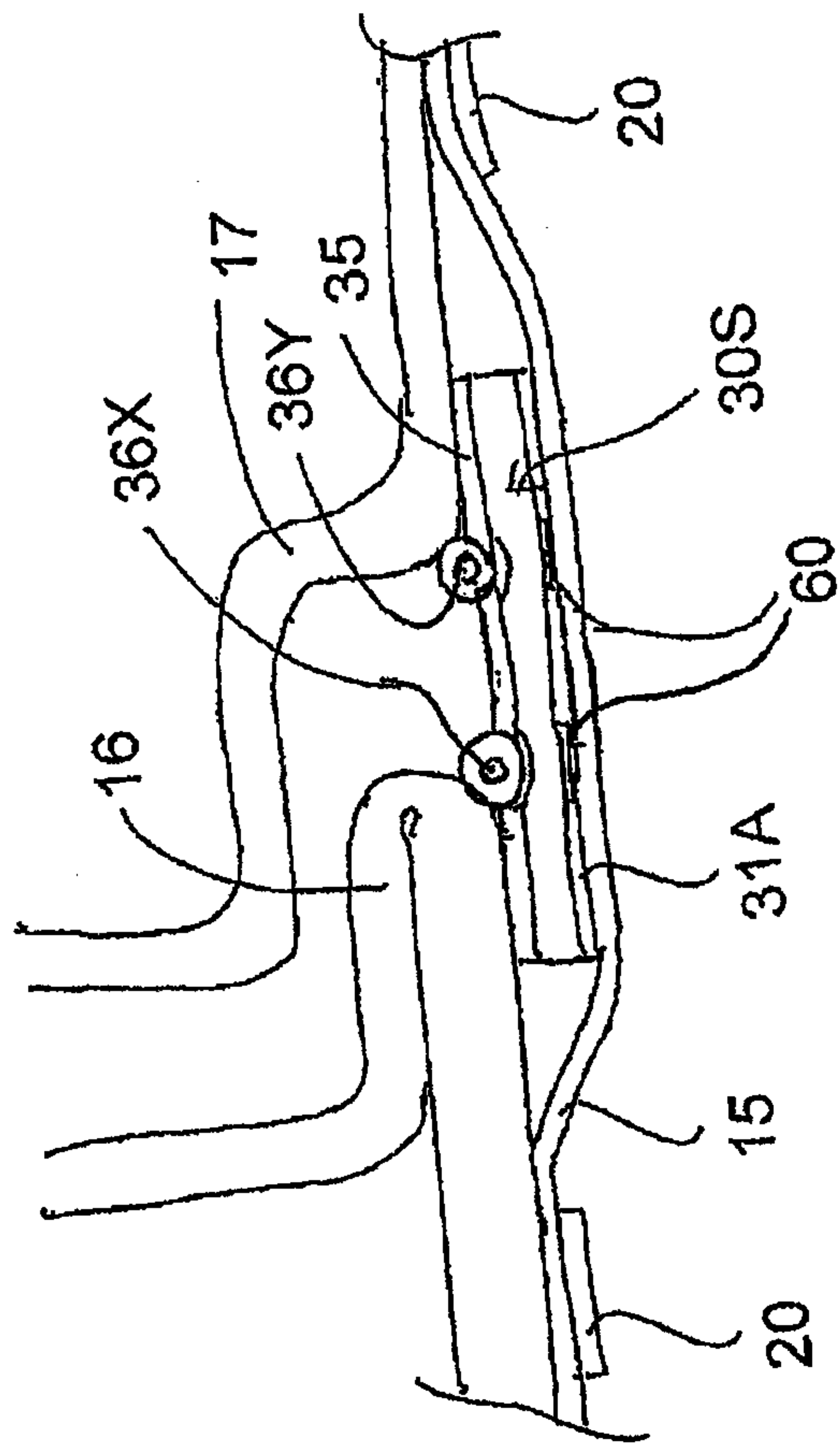

FIG. 8C



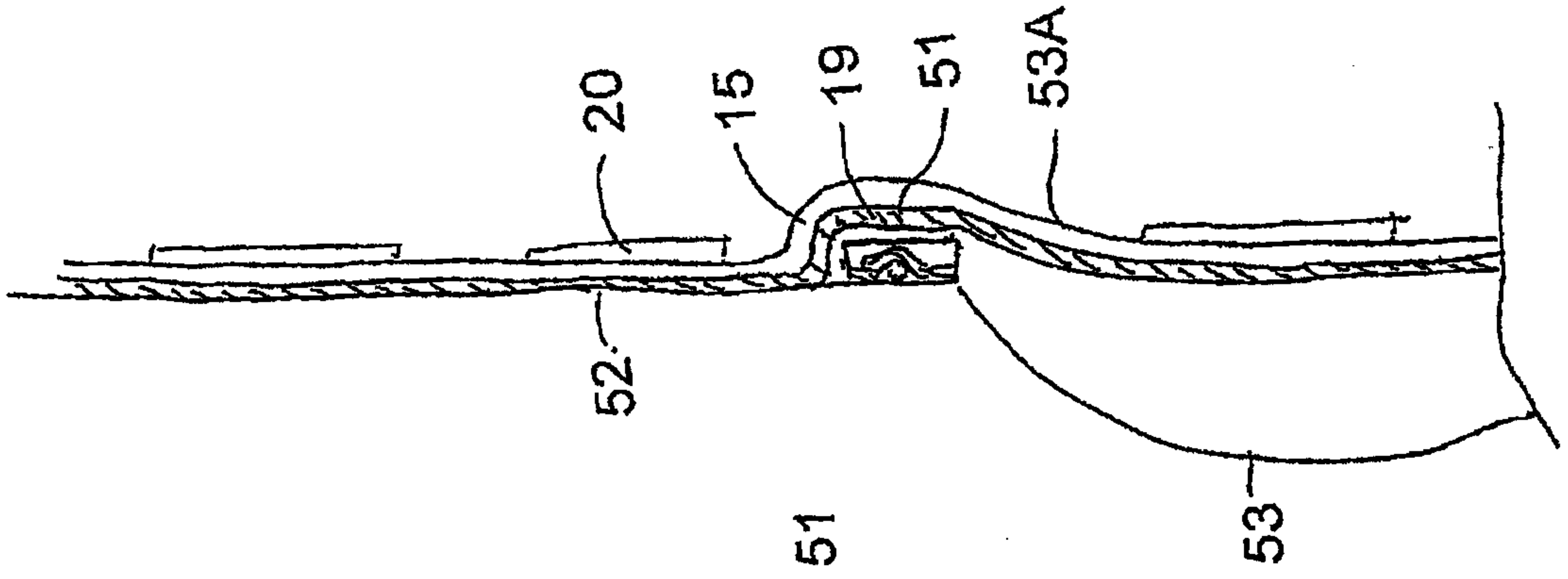

FIG. 10

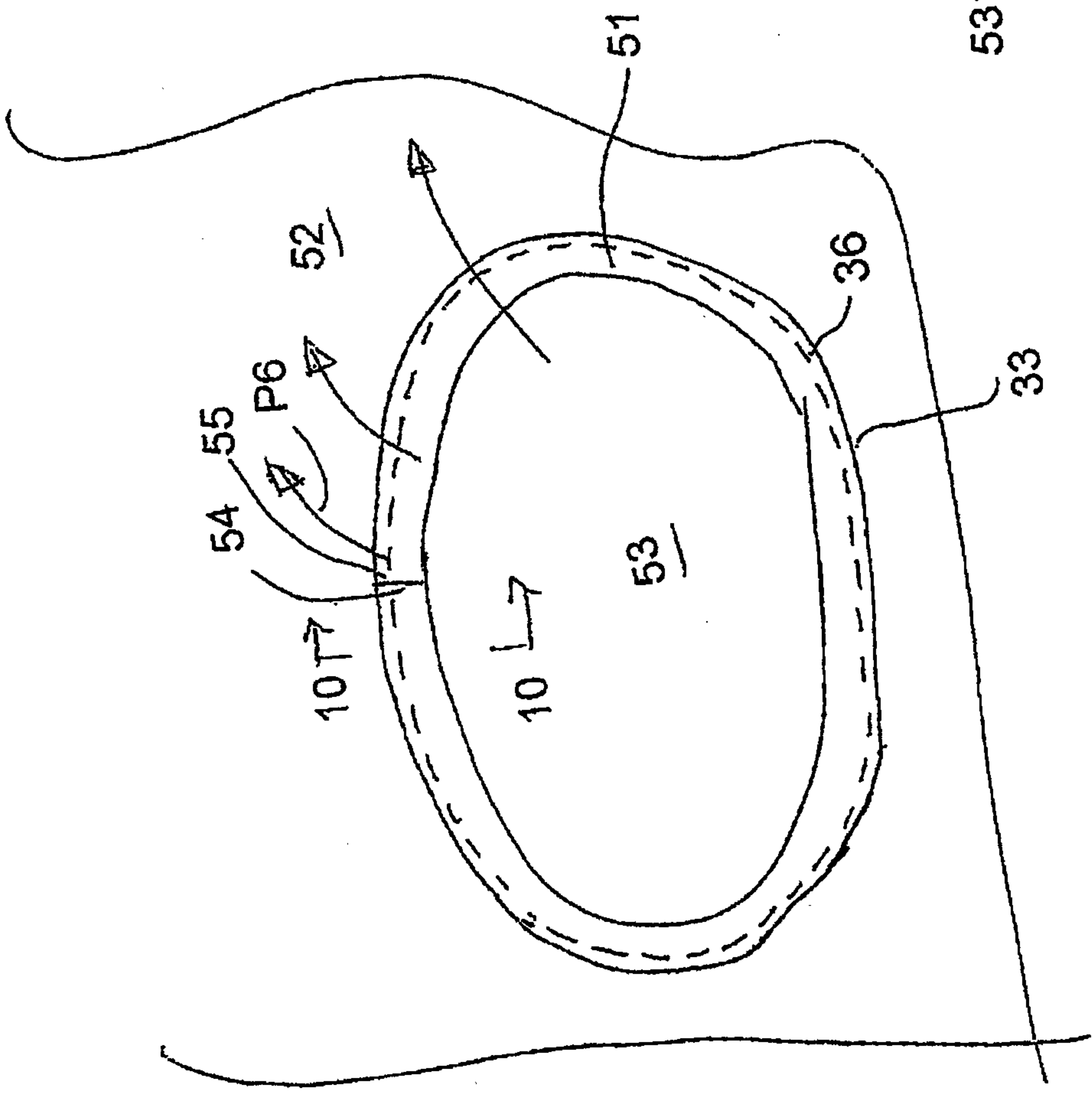

FIG. 9

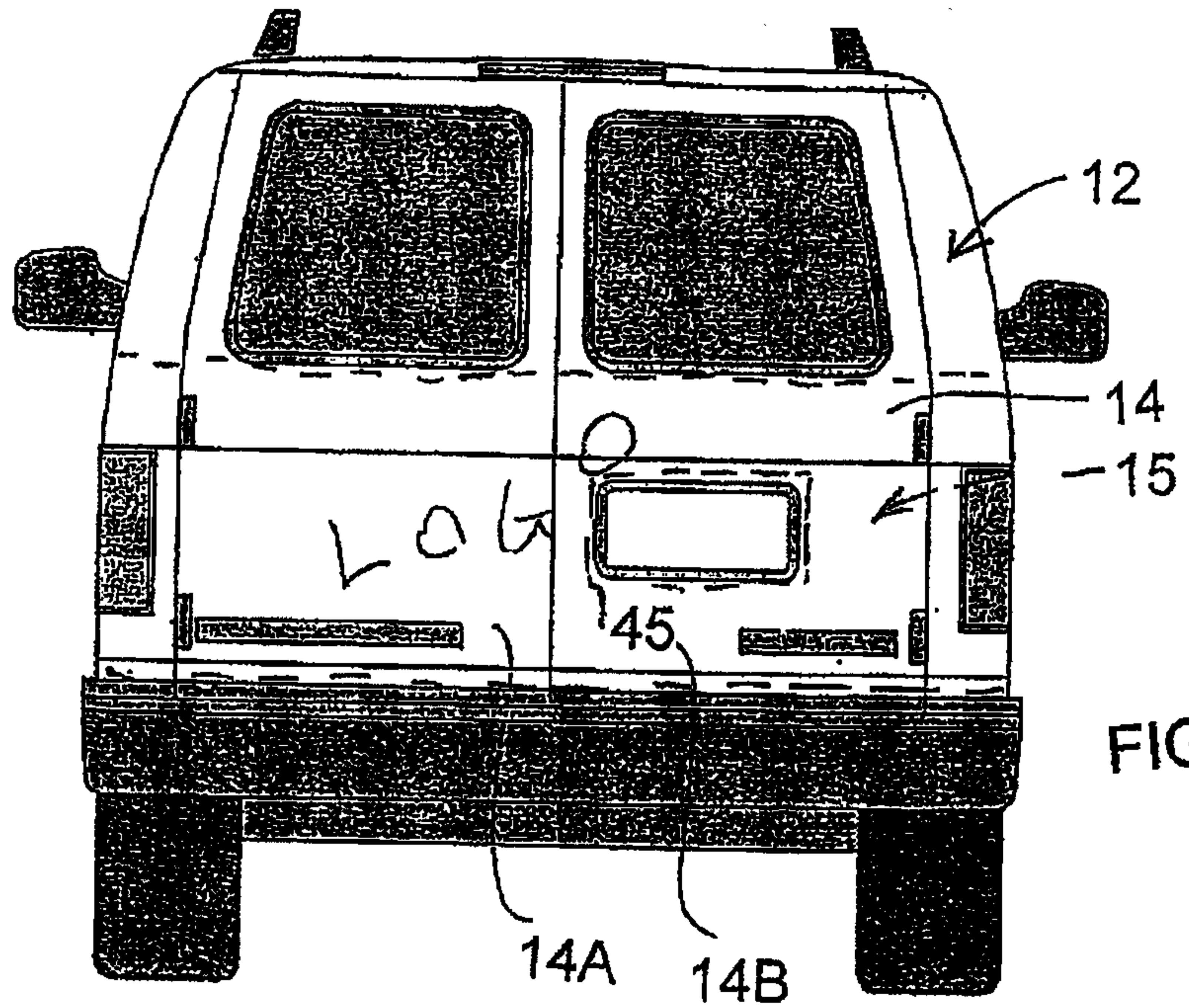

FIG. 11

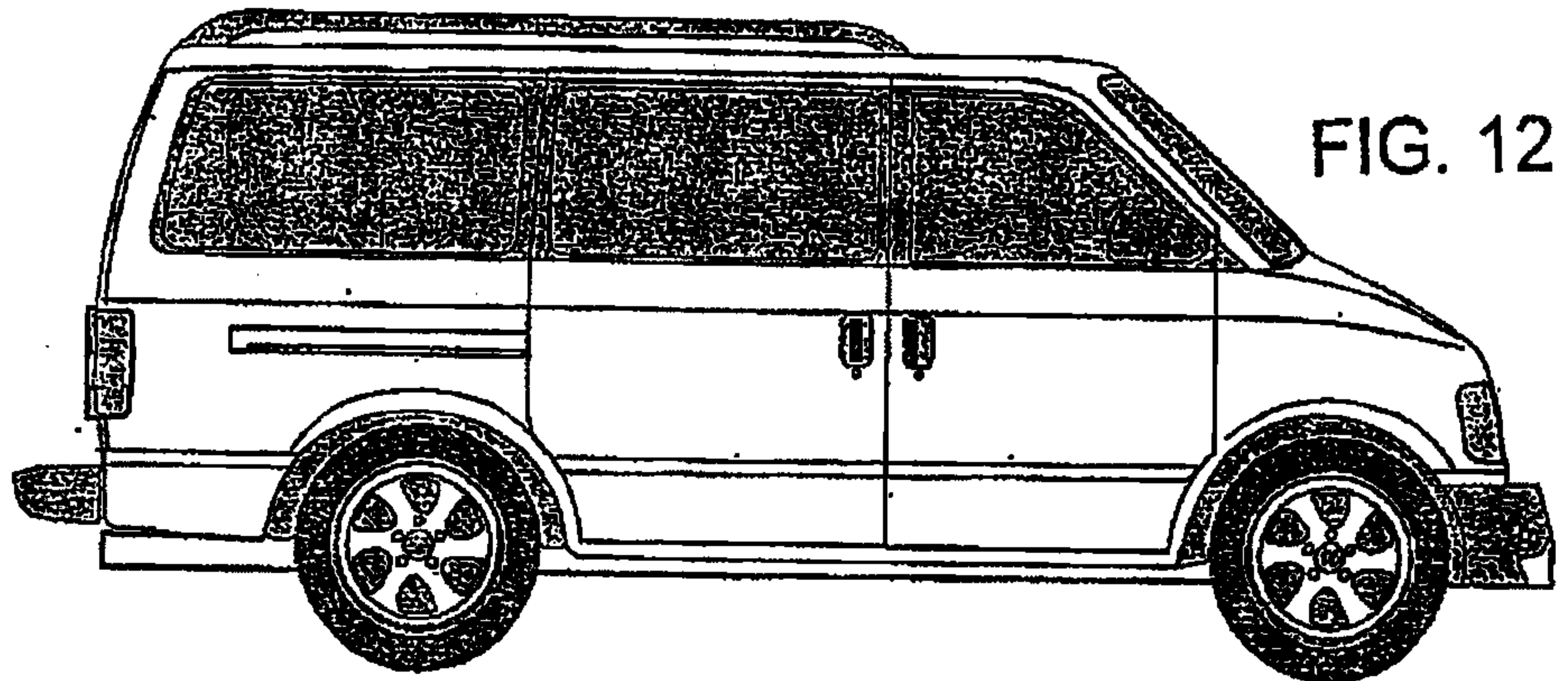

FIG. 12

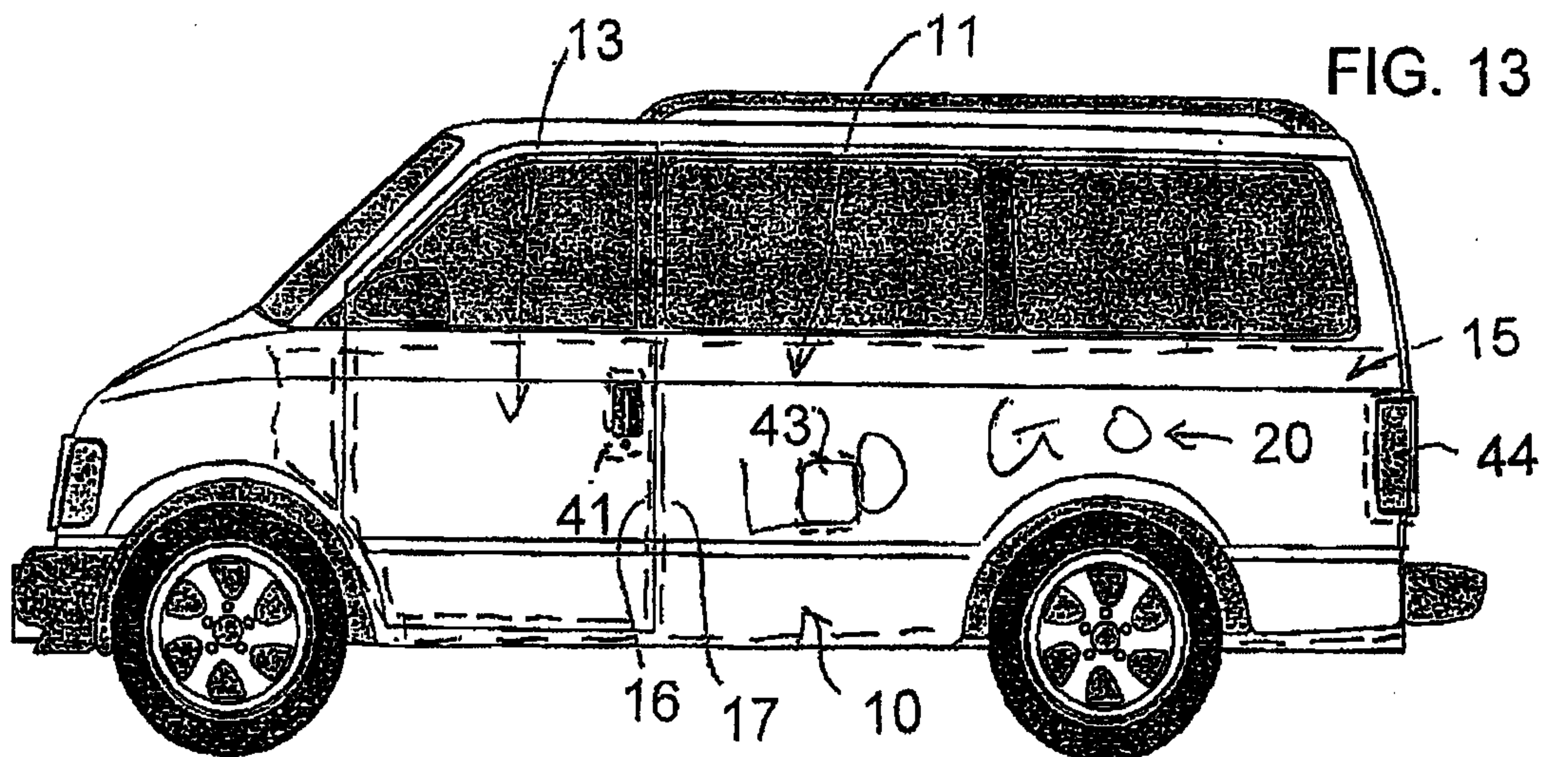

FIG. 13

