

No. 675,366.

Patented May 28, 1901.

E. N. GILFILLAN.  
CAR SEAT.

(Application filed May 2, 1898.)

(No Model.)

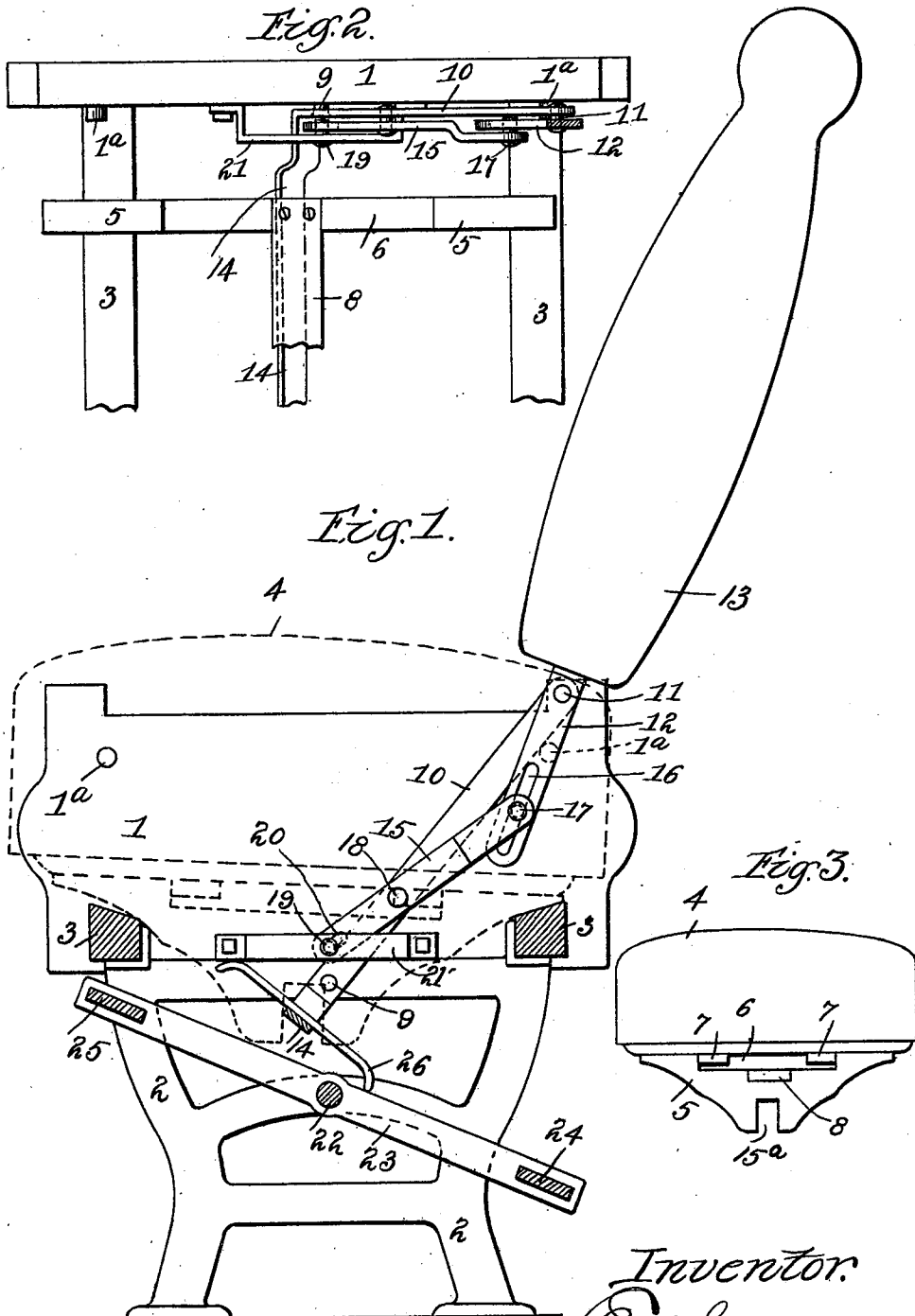

Witnesses.  
 Wm. M. Rhein.  
 Edna Johnson

Inventor.  
 E. N. Gilfillan  
 By Edw. H. Hoffmann  
 atty

# UNITED STATES PATENT OFFICE.

ESSINGTON N. GILFILLAN, OF CHICAGO, ILLINOIS.

## CAR-SEAT.

SPECIFICATION forming part of Letters Patent No. 675,366, dated May 28, 1901.

Application filed May 2, 1898. Serial No. 679,459. (No model.)

*To all whom it may concern:*

Be it known that I, ESSINGTON N. GILFILLAN, a citizen of the United States, residing at Chicago, in the county of Cook and State of Illinois, have invented certain new and useful Improvements in Car-Seats, of which the following is a full, clear, and exact specification.

My invention relates to that class of seats employed in cars and for other purposes which have a shiftable back and seat-cushion whereby the facing direction of the seat and the inclination of the cushion may be changed at will.

The primary object of my invention is to provide an improved, simple, and durable means whereby the seat-back may be readily shifted forward and back to change the facing direction and, if desired, also simultaneously alter the inclination of the seat-cushion to suit either position without the employment of objectionable projecting arms or other exposed devices having a shearing or pinching action liable to cause injury to the fingers of children or to others while occupying or operating the seat.

Another important object of my invention is to make the construction of such a character that the parts may be composed of ordinary bar-steel or steel forgings, thus avoiding breakage and saving expense, while being light, durable, and very compact.

Another object of my invention is to cause the bodily throw of the back by a comparatively short arm pivoted far up under the seat-cushion and to provide for the requisite tilt or inclination of the back by causing its upper edge to automatically recede toward the seat in a direction opposite to that in which such arm moves when the back is being shifted.

Another object of my invention is to automatically tilt the foot-rest on either side of the seat, so that the rest in front may always be high enough to admit a valise or other object under the seat.

A still further object of my invention is to provide an improved seat of this character which shall be of such a construction that the seat-cushions during storage or shipment may be stacked in a compact pile or form notwith-

standing the necessity for the employment of the usual rockers thereunder while in position for use.

With these ends in view my invention consists in certain features of novelty in the construction, combination, and arrangement of parts by which the said objects and certain other objects hereinafter appearing are attained, all as fully described, with reference to the accompanying drawings, and more particularly pointed out in the claims.

In the said drawings, Figure 1 is a vertical transverse sectional view of my improved car-seat, taken on the line 1 1, Fig. 2, the seat-cushion and the rockers which support it being shown in dotted lines. Fig. 2 is a plan sectional view of one end of the seat, the back and cushion being removed. Fig. 3 is a detail view, on a small scale, of the cushion and one of its rockers.

In illustrating my invention I have shown one end of the seat only; but it will nevertheless be understood that the mechanism is the same at both ends, and therefore the description of one end will suffice for the two.

1 represents one of the end frames of the seat, supported upon suitable legs or standards 2 and having longitudinal sills 3, which connect the end frames of the seat together and support the seat-cushion 4 in a well-known or suitable manner. The seat-cushion 4, which is shown in dotted lines in Fig. 1 and in full lines in Fig. 3, is made detachable from and rests upon the usual rockers 5, one of which is arranged at or near each end of the cushion and extends across the beveled sills 3 in the usual manner; but instead of securing the cushion 4 permanently to the rockers 5 I provide such rockers in their upper edges with a recess or notch 6, while the bottom of the seat-cushion is provided with one or more longitudinal ribs or blocks 7, which fit into the recesses 6 of the rockers 5, and thus securely hold the seat-cushion from sliding out of place. In order that the rockers 5, which rest loosely upon the sills 3, may be compelled to retain their relative positions, I connect them together by a cross-bar 8. With this construction it will be seen that when it is desired to take the cushions off and

stack them up for shipment or storage or other purposes they may be readily lifted off the seat and stacked up in a compact and neat pile without having the rockers, as heretofore, defeat this desirable end.

Pivoted at 9 to the inner side of each of the end frames 1 is an upright arm 10, whose extreme upper end is pivoted at 11 to a downwardly-extending rigid arm 12, secured in any suitable manner to the lower edge of each end of the back 13. The arms 10 are preferably composed of a more or less flat bar of steel or other suitable material and formed integrally with a longitudinal portion or bar 14, which extends from end to end of the seat and engages in the usual yokes or notches 15<sup>a</sup>, formed in the lower edges of the rockers 5, so that as the arms 10 are oscillated back and forth the rockers 5 will partake of such movement, but in the opposite direction, for imparting the desired shifting and inclination to the seat-cushion. The arms 10 are short as compared with the long radius of the arc described by the upper edge of the seat-back, the pivots 9 of such arms being located far up under the seat-cushion, so that the lower ends of the arms, as well as the bar 14, will be substantially excluded from view and prevented from causing injury; but in order that the upper edge of the seat-back may swing on an arc of greater radius than the distance between such upper edge and the pivot 9 I resort to the mechanism which I will now describe and which not only effects this desired end by causing the upper edge of the back to recede toward the seat in the direction opposite to the direction in which its lower edge moves, but is compact, simple, and durable. To effect this movement, I provide the lower end of the arm 12 with sliding connection with another arm 15, which is pivoted to the arm 10, and also has its lower end restricted against movement independent of such arm 10. This sliding connection between the upper end of the arm 15 and the lower end of the arm 12 may be best effected by means of a longitudinal slot 16, formed in the arm 12, and a sliding stud or pin 17, projecting from the side of the arm 15, the pivotal connection between the arms 10 and 15 being effected by an ordinary pivot 18, while the lower end of the arm 15 is restricted against movement independent of the arm 10 by a stud or pin 19; but in order that the arm 15 may oscillate upon its pivot 18 as the arm 10 swings from side to side, and thus cause the upper edge of the back to recede toward the seat in a direction opposite to the direction in which the arm 10 moves, the lower end of the arm 15 must be allowed longitudinal movement with reference to the pivot 19, and I therefore provide such lower end with a slot 20, through which the pivot 19 passes. The pivot 19 is mounted upon a bridge or bracket 21, which extends across the lower ends of the arms 10 15, as clearly

shown in Fig. 2, thus allowing the arms to oscillate and to pass each other. With this construction it will be seen that when the seat-back is in a vertical or central position all of the pivots 11, 17, 18, 19, and 9 are in direct line; but when the back is shifted onto the right side, for instance, the pivots 9, 19, and 18 form a triangle on one side of the longitude of the arm 10, while the pivots 18, 17, and 11 form a similar triangle on the opposite side. As the back shifts from a central position to one extremity of its movement it is carried bodily in that direction by the arm 10; but inasmuch as the lower end of the arm 15 cannot follow its upper end with the arm 10 the pivot 18 acts as a fulcrum and forces the pivot 17 in the direction of movement of the arm 10, but at a greater speed, so that by the time the back has reached the limit of its shifting stroke the upper edge of the back will have receded toward the seat in a direction opposite to the movement of the arm 10 a sufficient distance to prevent its upper edge from inclining too far for the comfort of the sitter.

All of these parts, it will be seen, may be constructed of ordinary bar-steel or steel forgings.

The back is limited in its shifting movement in either direction by a stud or stop 1<sup>a</sup> on the end frame.

Pivoted on a central shaft 22, at each end thereof, is a foot-rest arm 23, upon each end of which is supported one end of one of the foot-rests 24 25, and secured to the bar 14 is an arm 26, whose ends are so turned downwardly that when the seat is shifted in one direction the end of the bar 26 on that side will impinge the arm 23 and cause the foot-rest at the front of the seat to rise up close under the cushion and the other foot-rest to descend in a convenient position for the use of the passenger in the rear seat. When the seat-back is shifted in the opposite direction, the reverse movement of the foot-rests takes place.

Having thus described my invention, what I claim as new therein, and desire to secure by Letters Patent, is—

1. A seat having in combination a shiftable back having the slotted arm 12, the pivoted arm 10, the lever 15 pivoted to the arm 10, the stud 17 secured to lever 15 and engaging in the slot of arm 12, the bridge 21 having stud or fulcrum 19 provided with sliding connection with the lever 15 and stops arranged to engage with the arms 10 for limiting its movement, substantially as set forth.

2. A seat having in combination the arms 10 and horizontal bar 14 formed integrally, the end frames of the seat to which said arms 10 are pivoted, the shiftable back having operative connection with said arms 10, a shiftable seat-cushion and operative connection between said cushion and the bar 14, substantially as set forth.

3. A car-seat having in combination a shift-  
able back, a double foot-rest projecting from  
both sides of the seat and having arms 23, a  
centrally-located pivot-shaft for said foot-rest  
5 and a rocking arm 26 arranged to impinge  
one of said arms 23 alternately on opposite  
sides of said pivot-shaft and means for oper-

atively connecting said arm 26 with said shift-  
able back, substantially as set forth.

ESSINGTON N. GILFILLAN.

Witnesses:

EDNA B. JOHNSON,  
F. A. HOPKINS.