



(12) **DEMANDE DE BREVET CANADIEN
CANADIAN PATENT APPLICATION**

(13) **A1**

(86) Date de dépôt PCT/PCT Filing Date: 2019/08/05
(87) Date publication PCT/PCT Publication Date: 2020/02/13
(85) Entrée phase nationale/National Entry: 2020/12/17
(86) N° demande PCT/PCT Application No.: EP 2019/071029
(87) N° publication PCT/PCT Publication No.: 2020/030596
(30) Priorité/Priority: 2018/08/06 (DE10 2018 119 039.5)

(51) Cl.Int./Int.Cl. *B01F 7/00* (2006.01),
C02F 3/12 (2006.01)
(71) Demandeur/Applicant:
INVENT UMWELT- UND VERFAHRENSTECHNIK AG,
DE
(72) Inventeur/Inventor:
HOFKEN, MARCUS, DE
(74) Agent: PERRY + CURRIER

(54) Titre : AGITATEUR SUBMERSIBLE POUR LA CIRCULATION D'EAU POTABLE
(54) Title: SUBMERSIBLE AGITATOR DEVICE FOR CIRCULATING DRINKING WATER

Fig. 1

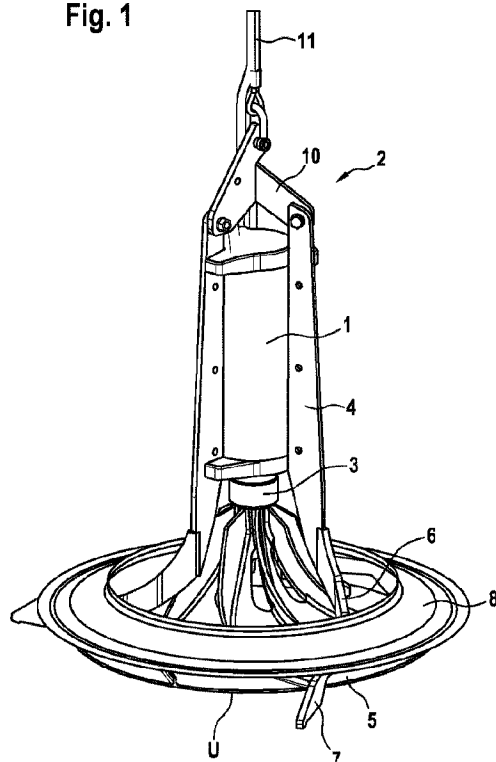

(57) **Abrégé/Abstract:**

The invention relates to a submersible agitator device for circulating drinking water, comprising a submersible motor having a cylindrical housing (1), from one end of which a shaft (3) extends, a hyperboloid agitator body (5) attached to the shaft (3), a frame (2) having a plurality of supports (4), which extend along the housing (1) and are connected to the housing (1), wherein the supports (4) have bend portions (6) which bend radially to the outside and which extend over a circumferential edge (U) of the hyperboloid agitator body (5) in order to support the frame (2) on a base, and an air flow guiding element (8), designed to be ring-like in plan view, which is attached to the bend portions (U) of the supports (4).

Abstract

The invention relates to a submersible agitator device for circulating drinking water, comprising

5

a submersible motor comprising a cylindrical housing (1), from one end of which there extends a shaft (3),

a hyperboloid agitator (5) mounted on the shaft (3),

10

a frame (2) with a plurality of supports (4) extending along the housing (1) and connected to the housing (1), wherein the supports (4) have radially outwardly angled bend portions (6), which extend over a peripheral edge (U) of the hyperboloid agitator body (5) in order to support the frame (2) on a base, and

15

a flow-guiding element (8), which is annular in plan view and which is mounted on the bend portions (U) of the supports (4).

Submersible agitator device for circulating drinking water

5 The invention relates to a submersible agitator device for circulating drinking water, comprising a submersible motor with a housing, from one end of which there extends a shaft, a hyperboloid agitator body mounted on the shaft, and a support structure for supporting the submersible agitator device on the base of a tank.

10 A submersible agitator device is offered by the applicant under the name "Hyper-dive Mixer". It is used to circulate in particular wastewater in a clarification tank.

15 In drinking water stores there is the risk of formation of water layers having different temperatures. There is no significant liquid exchange between water layers of this kind. This may result in algae formation, post-bacterial load and/or may lead to an uncontrolled chemical concentration. In order to avoid the above-mentioned disadvantages, drinking water received in a drinking water store is circulated by means of an agitator device.

20 The object of the present invention is to specify a submersible agitator device for circulating drinking water which has an improved agitation efficiency.

This object is achieved by the features of claim 1. Expedient embodiments of the invention will become clear from the features of the dependent claims.

25 In accordance with the invention a submersible agitator device for circulating drinking water is proposed and comprises:

a submersible motor having a cylindrical housing, from one end of which there extends a shaft.

30

a hyperboloid agitator body mounted on the shaft,

a frame with a plurality of supports extending along the housing and connected to the housing, wherein the supports have radially outwardly angled bend portions, which extend over a peripheral edge of the hyperboloid agitator body in order to support the frame on a base, and

5

a flow-guiding element, which is annular in plan view and which is mounted on the bend portions of the supports.

The proposed submersible agitator device is of a simple and compact design. Due to the provision of the annular flow-guiding element, circular or spiralled vortices at the periphery of the hyperboloid agitator body are avoided. Consequently, the proposed submersible agitator device has a particularly high agitation efficiency, i.e. a predefined amount of drinking water can be circulated with the proposed submersible agitator device with reduced expenditure of energy.

15

In accordance with an advantageous embodiment, transport ribs are provided on an upper side of the hyperboloid agitator body facing the submersible motor and extend in the radial direction and bend towards the peripheral edge in a first tangential direction. The proposed embodiment of the transport ribs contributes further to increasing the efficiency of the submersible agitator device. As the hyperboloid agitator body rotates, a flow directed to the upper side thereof is generated and is deflected in a radial direction towards the peripheral edge.

20

The flow-guiding element is advantageously supported on the bend portions. However, it can also be mounted on a lower edge of the bend portions facing the hyperboloid agitator body. It is expediently welded to the bend portions.

25

The flow-guiding element advantageously tapers conically in the direction of the housing. This contributes to an avoidance of undesirable vortices, in particular circular or spiralled vortices.

30

In accordance with a further advantageous embodiment the frame comprises precisely three supports. The proposed construction of the frame is simple and compact. Apart from this, it is ensured that the submersible agitator device is supported on the base of a tank in a manner secure against tilting.

5

In a plan view of the upper side of the agitator element, the bend portions of the supports advantageously bend in a second tangential direction opposite the first tangential direction. The second tangential direction corresponds substantially to the direction of the water flowing from the peripheral edge of the agitator body.

10 The formation of undesirable flow obstacles and thus of vortices is also counteracted as a result of the proposed embodiment. The efficiency of the proposed submersible agitator device can thus also be increased.

In accordance with a further embodiment the supports are connected to one another by means of a connection element at another end of the housing opposite
15 the shaft-side end. This makes it possible to easily mount a cable for lifting and lowering the proposed submersible agitator device.

The hyperboloid agitator body is expediently made from stainless steel in one
20 piece with the transport ribs in the form of a cast part. Likewise, the housing, the flow-guiding element and the frame can be made from stainless steel. A steel of the composition X6CrNiMoTi17-12-2 is preferably used as high-grade steel. In addition, a steel with the composition X2CrNiMo17-12-2 can also be used. Steels of this kind are particularly suitable for circulating drinking water in drinking water
25 stores.

An exemplary embodiment of the invention will be explained hereinafter with reference to the drawings, in which:

30 Fig. 1 shows a perspective view of a submersible agitator device,

Fig. 2 shows a side view according to Fig. 1,

Fig. 3 shows a plan view according to Fig. 1, and

Fig. 4 shows a view from below according to Fig. 1.

5

In the case of the submersible agitator device shown in the drawings a submersible motor is mounted on a frame, denoted generally by reference sign 2. A shaft 3 extends from the submersible motor, which has a cylindrical housing 1. A hyperboloid agitator body 5 is mounted on the shaft 3. Such a hyperboloid agitator body 5 is known for example from DE 10 2013 225 658 A1.

The frame 2 comprises a plurality of supports 4 extending along the housing 1 and connected to the housing 1. The supports 4 extend over the housing 1 in the direction of the hyperboloid agitator body 5. The supports 4, in a portion situated above the hyperboloid agitator body 5, have radially outwardly angled bend portions 6. The bend portions 6 extend over a peripheral edge U of the hyperboloid agitator body 5 and at their end each have a foot 7 for supporting the frame 2 on a base.

A flow-guiding element 8, which is annular in plan view, is supported on the bend portions 6. The flow-guiding element 8 is fixedly connected to the bend portions 6, for example by means of welding.

The hyperboloid agitator body 5 has transport ribs 9 on an upper side facing the housing 1. The hyperboloid agitator body 5 is expediently produced from stainless steel in one piece with the transport ribs 9 in the form of a cast part.

The transport ribs 9 extend along the surface of the hyperboloid agitator body 5 firstly in a radial direction, starting from the shaft 3. They then bend towards the peripheral edge U in a first tangential direction.

30

As can be seen in particular from Fig. 3, in a plan view of the upper side of the hyperboloid agitator body 5, the bend portions 6 of the supports 4 bend in a second

tangential direction, opposite the first tangential direction. The flow-guiding element 8 tapers conically in the direction of the housing 1. Reference sign 10 denotes a connection element, which connects the supports 4 to one another at another end of the housing 1, opposite the shaft-side end. A cable for lifting and lowering the submersible agitator device can be mounted on the connection element 10.

The function of the submersible agitator device is as follows:

10 The hyperboloid agitator body 5 is rotated in a clockwise direction by means of the submersible motor. Consequently, a flow forms which is directed towards the upper side of the hyperboloid agitator body 5. The flow passes through the flow-guiding element 8. It is deflected in a radial direction by the action of the flow-guiding element 8 and the effect of the hyperboloid agitator body 5. The flow from the peripheral edge U likewise circulates in a clockwise direction. Due to the bend of the bend portions 6 provided in a second tangential direction, the flow encounters only a very low resistance over its path. Due to the effect of the flow-guiding element 8, the formation of spiralled vortices is avoided. Drinking water can be circulated in a drinking water container with improved efficiency by means of the proposed submersible agitator device. Due to the embodiment proposed in accordance with the invention, less electrical energy than in conventional submersible agitator devices is required for the circulation.

List of reference signs

- 1 housing
- 2 frame
- 5 3 shaft
- 4 support
- 5 hyperboloid agitator body
- 6 bend portion
- 7 foot
- 10 8 flow-guiding element
- 9 transport rib
- 10 connection portion

- U peripheral edge
- 15

Claims

1. A submersible agitator device for circulating drinking water, comprising
5 a submersible motor comprising a cylindrical housing (1), from one end of which there extends a shaft (3),

a hyperboloid agitator (5) mounted on the shaft (3),
10 a frame (2) with a plurality of supports (4) extending along the housing (1) and connected to the housing (1), wherein the supports (4) have radially outwardly angled bend portions (6), which extend over a peripheral edge (U) of the hyperboloid agitator body (5) in order to support the frame (2) on a base, and
15 a flow-guiding element (8), which is annular in plan view and which is mounted on the bend portions (U) of the supports (4).
2. The submersible agitator device according to claim 1, wherein transport ribs (9) are provided on an upper side of the hyperboloid agitator body (5) facing the
20 submersible motor and extend in the radial direction and bend towards the peripheral edge (U) in a first tangential direction.
3. The submersible agitator device according to either one of the preceding claims, wherein, in a plan view of the upper side of the hyperboloid agitator ele-
25 ment (5), the bend portions (U) of the supports (4) bend in a second tangential direction opposite the first tangential direction.
4. The submersible agitator device according to any one of the preceding
30 housing (1).

5. The submersible agitator device according to any one of the preceding claims, wherein the frame (2) comprises precisely three supports (4).

6. The submersible agitator device according to any one of the preceding
5 claims, wherein the supports (4) are connected to one another by means of a connection element (10) at another end of the housing (1) opposite the shaft-side end.

7. The submersible agitator device according to any one of the preceding
10 claims, wherein the hyperboloid agitator body (5) is made from stainless steel in one piece with the transport ribs (9) in the form of a cast part.

8. The submersible agitator device according to any one of the preceding
15 claims, wherein the housing (1), the flow-guiding element (8) and the frame (2) is made from stainless steel.

1 / 3

Fig. 1

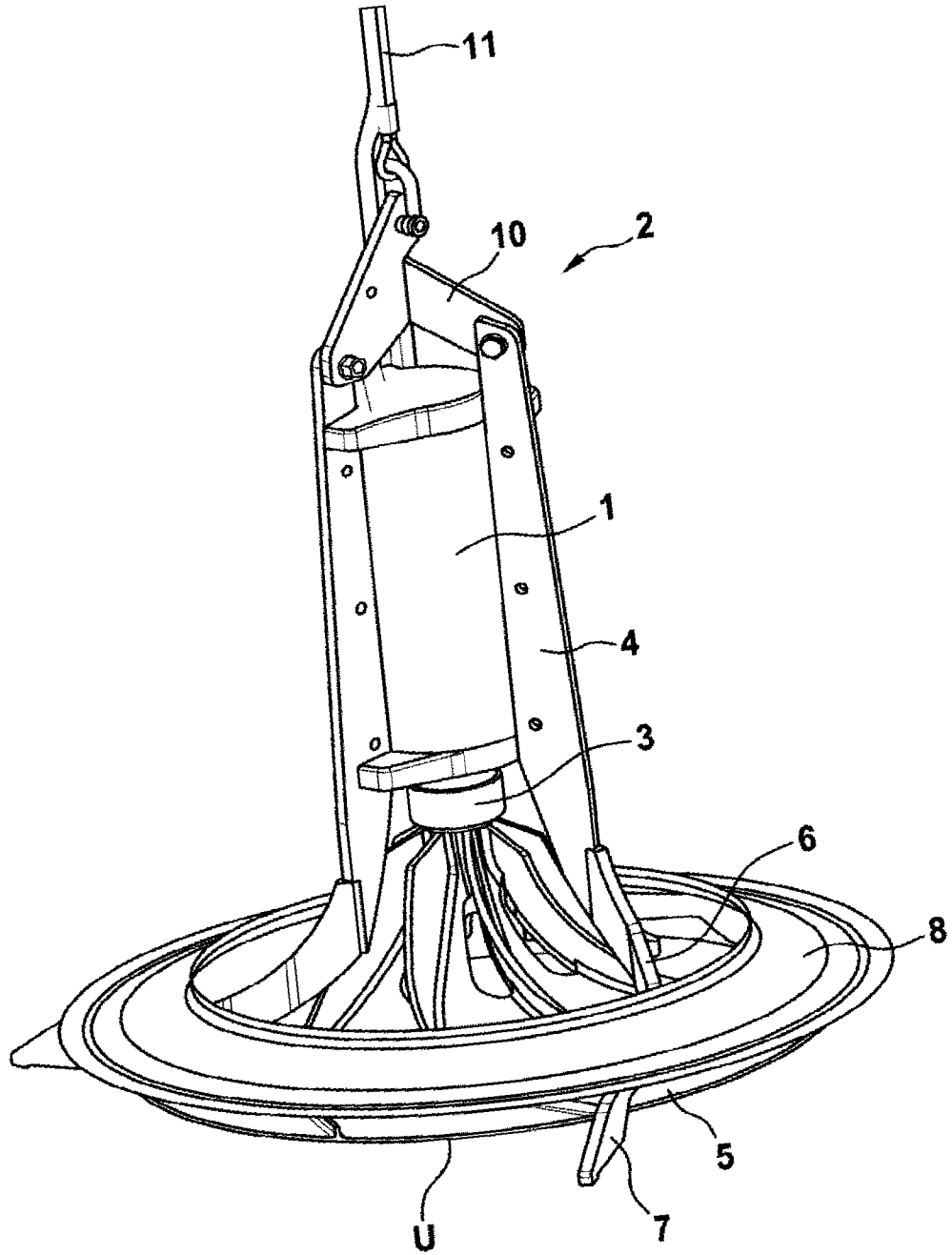

2 / 3

Fig. 2

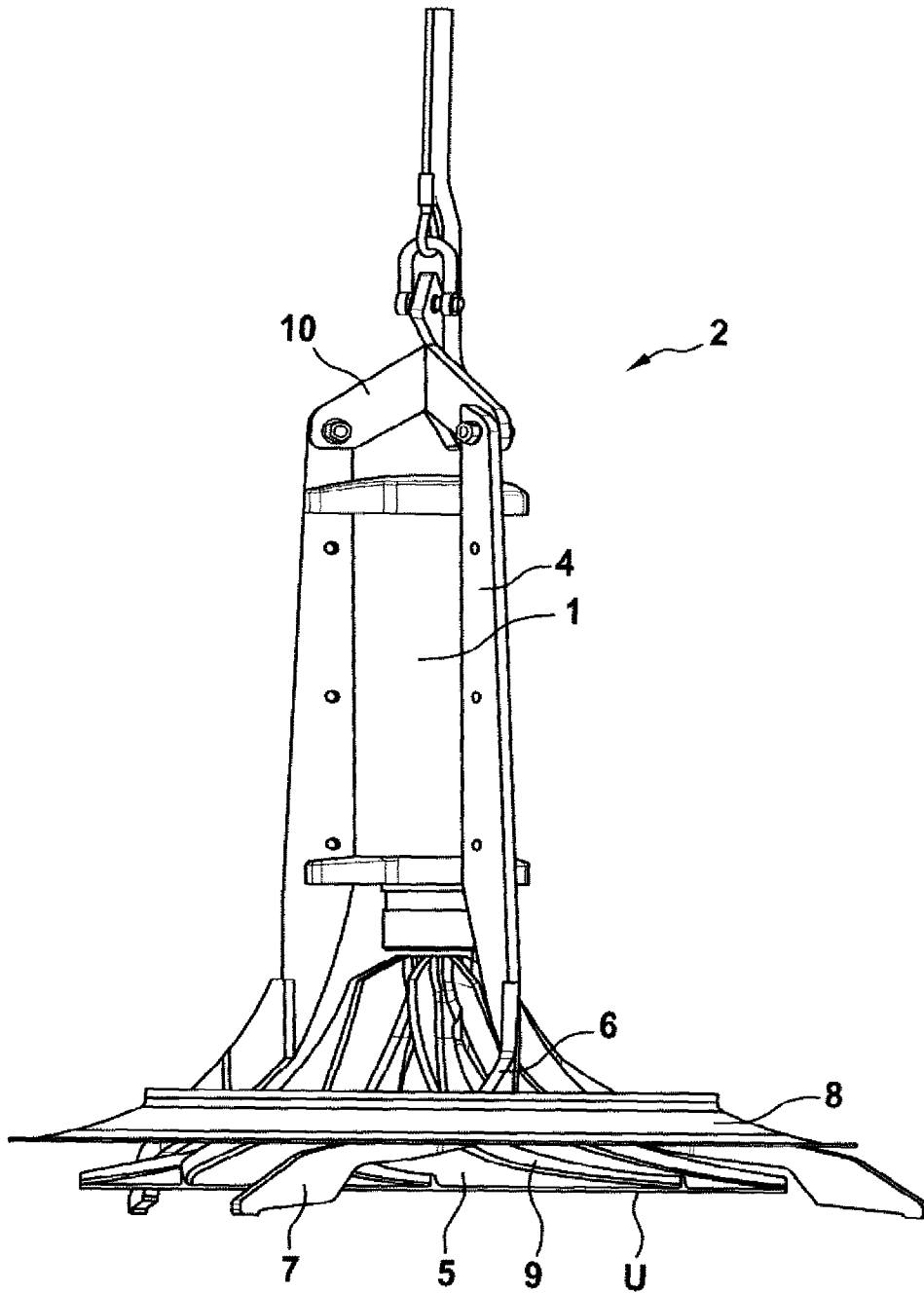

3 / 3

Fig. 3

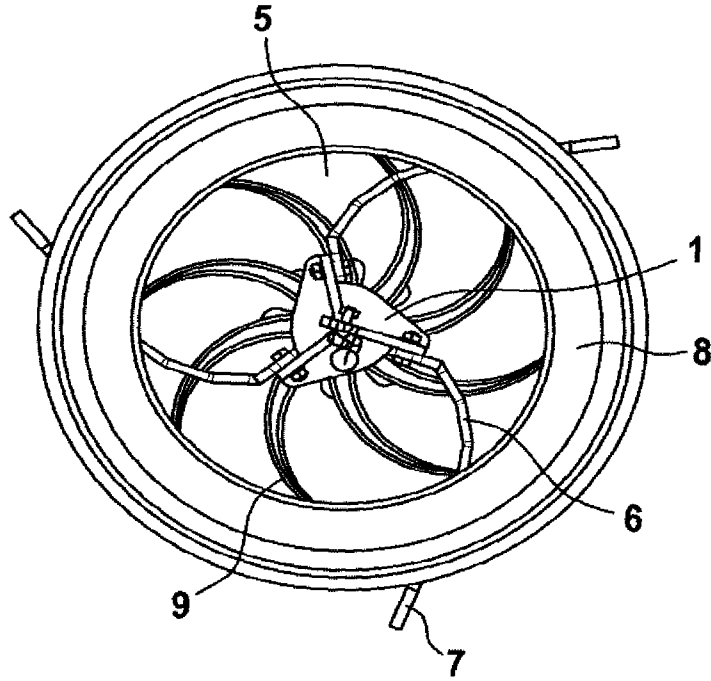

Fig. 4

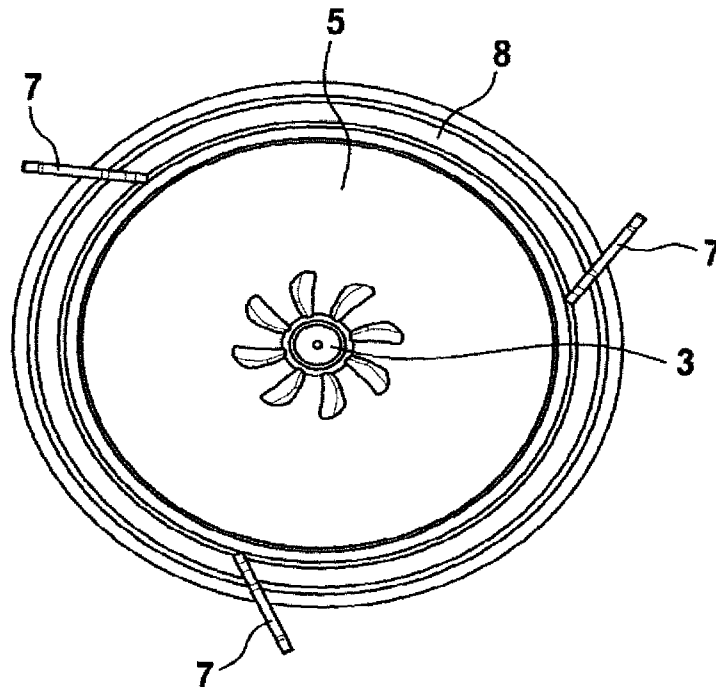

Fig. 1

