

(19) World Intellectual Property
Organization
International Bureau



(43) International Publication Date
3 March 2005 (03.03.2005)

PCT

(10) International Publication Number
WO 2005/019033 A2

- (51) International Patent Classification⁷: **B65B** Oakbook, IL 60523 (US). **DITCHFIELD, Patrick** [US/US]; 3454 NO. Natoma Ake, Chicage, IL 60634 (US).
- (21) International Application Number: PCT/US2004/027186
- (22) International Filing Date: 20 August 2004 (20.08.2004)
- (25) Filing Language: English
- (26) Publication Language: English
- (30) Priority Data: 60/496,445 20 August 2003 (20.08.2003) US
- (71) Applicants (for all designated States except US): **MULTIVAC, INC.** [US/US]; 11021 N.W. Pomona Avenue, Kansas City, MO 64153 (US). **RDI-IBA TECHNOLOGY GROUP** [US/US]; 151 Heartland Blvd., Edgewood, NY 11747-8374 (US).
- (72) Inventors; and
- (75) Inventors/Applicants (for US only): **SLOMSKI, Douglas, B.** [US/US]; 2107 Grand Blvd., Suite 504, Kansas City, MO 64108 (US). **GALLOWAY, Richard** [US/US]; 151 Heatland Blvd., Edgewood, NY 11747-8374 (US). **POTH, Steven** [US/US]; 2015 Spring Road, Suite 650,
- (74) Agents: **DONAHUE III, Denis, J.M.** et al.; Husch & Eppenberger, LLC, 190 Carondelet Plaza, Suite 600, St. Louis, MO 63105 (US).
- (81) Designated States (unless otherwise indicated, for every kind of national protection available): AE, AG, AL, AM, AT, AU, AZ, BA, BB, BG, BR, BW, BY, BZ, CA, CH, CN, CO, CR, CU, CZ, DE, DK, DM, DZ, EC, EE, EG, ES, FI, GB, GD, GE, GH, GM, HR, HU, ID, IL, IN, IS, JP, KE, KG, KP, KR, KZ, LC, LK, LR, LS, LT, LU, LV, MA, MD, MG, MK, MN, MW, MX, MZ, NA, NI, NO, NZ, OM, PG, PH, PL, PT, RO, RU, SC, SD, SE, SG, SK, SL, SY, TJ, TM, TN, TR, TT, TZ, UA, UG, US, UZ, VC, VN, YU, ZA, ZM, ZW.
- (84) Designated States (unless otherwise indicated, for every kind of regional protection available): ARIPO (BW, GH, GM, KE, LS, MW, MZ, NA, SD, SL, SZ, TZ, UG, ZM, ZW), Eurasian (AM, AZ, BY, KG, KZ, MD, RU, TJ, TM), European (AT, BE, BG, CH, CY, CZ, DE, DK, EE, ES, FI, FR, GB, GR, HU, IE, IT, LU, MC, NL, PL, PT, RO, SE, SI,

[Continued on next page]

(54) Title: **INLINE PROCESSING AND IRRADIATION SYSTEM**

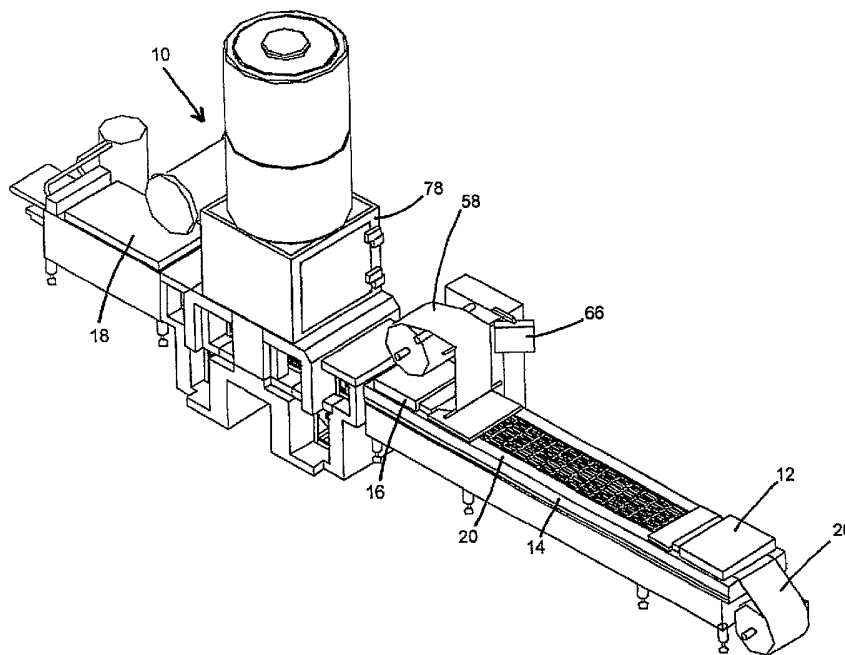

(57) Abstract: A stream of products is packaged and biologically treated by the system. The system has an index conveyor with a filling station and a packaging station. Discrete packages are filled with the stream of products, sealed and moved on an index conveyor. The system moves the discrete packages an irradiation chamber at a steady rate on a continuous speed conveyor. A controller matches the cyclical rate of the index conveyor with the steady rate of the continuous speed conveyor and uses a buffer to transition from the cyclical rate to the steady rate.

WO 2005/019033 A2



SK, TR), OAPI (BF, BJ, CF, CG, CI, CM, GA, GN, GQ,
GW, ML, MR, NE, SN, TD, TG).

For two-letter codes and other abbreviations, refer to the "Guidance Notes on Codes and Abbreviations" appearing at the beginning of each regular issue of the PCT Gazette.

Published:

— *without international search report and to be republished upon receipt of that report*

SYSTEM FOR INLINE PACKAGING AND IRRADIATION OF ARTICLES**Cross-Reference to Related Applications**

This application claims priority to United States Provisional Patent Application No. 60/496,445 filed on August 20, 2003.

Statement Regarding Federally Sponsored Research or Development.

Not Applicable.

Background of the Invention***1. Field of the Invention***

This invention relates generally to the process of packaging products in a conveyor system and, more particularly, to a process for simultaneously sterilizing a discrete amount of the product being packaged.

2. Related Art

Irradiation processing of materials for the purpose of material modification, reducing bioburden and product sterilization has been practiced for many years. This process involves passing the material or products through a stream or curtain of electrons or photons provided by an electron beam or X-ray accelerator. The delivered ionizing irradiation energy can, for example, then effectively cause free radical crosslinking as is done in polymeric materials, killing of organic pathogens as is done to reduce e-coli and other food borne pathogens or the elimination of harmful bacteria and microorganisms that contaminate medical devices and cause illness and infection in patients. This electron or X-ray energy penetrates deeply and sufficiently through the material being processed to effectively treat the entire volume of the product including the packaging material. Variations in energy of the electron beam and power of the accelerator system dictate depth of penetration and processing throughput for various products

Irradiation processing practices to date have been effectively implemented by treating finished goods after they leave the manufacturing/assembly process line. This process typically occurs at the end of the process where individual products have been collected and packed into the shipping and distribution cartons containing one or in most cases many individually packaged components. These materials are then transferred to a conveyor system which in turn transports the materials to be presented to the irradiator and subsequently processed. One embodiment of this process is described in US Patent No. 5,396,074 (Peck et al.) which consists of irradiation system and a multi-stage power and free overhead conveyor system used to transport carriers on which the product boxes or materials are loaded and subsequently processed. These products which are typically packaged in shipping cartons would require electron beam systems of higher energy to sufficiently penetrate the carton and multiple products in the carton to deliver the proper sterilization dose. The full system including the accelerator, radiation shielding and material handling conveyor system can be rather large, occupying typically thousands of square feet of floor space, and is not conducive to being placed into an inline manufacturing layout. This type of system is designed to irradiation processes for entire manufacturing plant outputs rather than individual or a few individual product manufacturing lines.

Variations in this design concept have been implemented which are physically smaller and sized to treat smaller volumes and fit better into a process line but these are still designed to treat boxes of products rather than individual products. Examples of these designs can be reviewed in systems supplied around the globe by Ion Beam Applications (IBA) of Louvain-la-Neuve Belgium, Radiation Dynamics Inc. (RDI) of Edgewood, New York, Scanditronics (SCX) of Uppsala, Sweden and Titan Scan Technologies of San Diego, California)

The sterilization processing of materials requires very strict control, product tracking

and many levels of quality assurance to properly qualify the end product sterility or properties. An example of the current industry practice implemented can be seen in irradiation processing done today in gamma, x-ray and electron beam sites where a typical product processed are individual boxes containing about one gross of medical syringes in each box. This packing box is typically labeled with a unique identifier such as a bar code label which would allow traceability to when the products inside were manufactured, processed etc. Once this box has been opened and the syringes are removed this "traceability" is lost as the individual syringes do not carry these identifiers. Process qualification will verify that a particular box was processed but not the individual contents. An example of a packaged radiation-sterilized medical device is shown in US Patent No. 4813,210 (Masuda et al.).

To date there have been a number of different approaches to address the sterilization/bio-burden reduction in packaged goods. These range from a post process sterilization as described above to various means for treating the packaging materials and products. An example of prior art described in US Patent No. 4,223,512 (Buchner) uses an alternating high-frequency electromagnetic field (RF or radio frequency waves) to sterilize food products in a form-fill and seal packaging line. The drawback of this method of treatment is the packaged goods are heated by the RF and subsequently partially "cooked" in this process. Another system is described in US Patent No. 4,983,411 (Tanaka et al.) which uses ultraviolet (UV) light as an irradiation means along with heat to sterilize vacuum packed raw meat. This means of irradiation treatment can be used to effectively control surface pathogens that can be exposed to the UV but fails to penetrate deeply into and through the material. Thus pathogens may still be present in the processed product which then requires that heat is employed along with the UV energy to properly treat the product. Other embodiments such as seen in US Patent Nos. 4,566,251 (Spisak et al.), 4,652,763 (Nablo), 4,994,132 (Carlsson et al.), 5,368,828

(Carlson), and 5,549,868 (Carlson II) describe septic sterilization system in which the packaging material is sterilized in-line, such as prior to filling the package with material or goods. Also, these prior art systems do not fully combine the efficiencies of in-line form-fill-seal packaging with the benefits of in-line sterilization of the product within the packaging before leaving the form-fill-seal packaging system. To efficiently combine in-line form-fill-seal packaging with in-line sterilization, the differences between to types of conveyors must be overcome. In prior systems, it is known to use an index feed system for the packaging system and to continuously supply product to an intermittently operating packaging machine, such as respectively described in US Patent Nos. 5,477,660 (Smith) and 5,685,130 (Horsman), which are incorporated herein by reference. However, these systems do not perform any treatment proces using a continuous feed.

Summary of the Invention

It is in view of the above problems that the present invention was developed. The invention is a form-fill-seal packaging system with an in-line biological treatment device. As described in detail below and recited in the claims, the biological treatment device uses irradiation to reduce biological contaminants or sterilize the packaged products. Preferably, a low to medium power, medium to high energy electron beam or x-ray system is integrated with the packaging system for the product packaging and biological treatment thereof. In one embodiment, a medium to high power, medium to high energy electron beam or X-ray system is integrated with an inline form-fill and seal packaging system to provide an integrated processing solution and means of packaging and irradiation sterilization or bio-burden reduction of various materials. Embodiments are shown which have a different types of buffer systems, including those in which allow the irradiation device is used before the packages are cut from their web,

such as with a roller accumulator or a slackening trough, as well as those in which the irradiation device is placed after the packages are cut from the web, such as with a bucket accumulator or a linear accumulator.

In the preferred embodiment, a stream of products is packaged and biologically treated by the system. The system has an index conveyor with a filling station and a packaging station. Discrete packages are filled with the stream of products, sealed and moved on an index conveyor. The system moves the discrete packages an irradiation chamber at a steady rate on a continuous speed conveyor. A controller matches the cyclical rate of the index conveyor with the steady rate of the continuous speed conveyor and uses a buffer to transition from the cyclical rate to the steady rate.

Accordingly, the present invention provides a means for irradiation processing of goods through the integration of an electron beam or X-ray irradiation device with a form-fill and seal type packaging system. This provides a means to allow the delivery of this irradiation energy to individually packaged items or devices in a single layer multiple array formats, while these items are being conveyed by the packing system. The electron beam or X-ray energy has the ability to sufficiently penetrate the packaging material and the product being processed while delivering an irradiation dose sufficient to kill microorganisms and sterilize the material or treat harmful pathogens in the case of food.

In the case of sterilization of a medical disposable product such as a syringe, it is important to deliver a sufficient radiation dose to kill the contaminating bacteria while the dose absorbed in the body of the syringe is minimized. This is important because the sterilizing energy may also degrade the mechanical properties of the plastics used in the body of the syringe, thus providing a minimum dose to these materials preserves the mechanical integrity of the device. Additionally, by minimizing the delivered dose we conserve energy and the power

requirements for the process are reduced.

Further features and advantages of the present invention, as well as the structure and operation of various embodiments of the present invention, are described in detail below with reference to the accompanying drawings.

Brief Description of the Drawings

The accompanying drawings, which are incorporated in and form a part of the specification, illustrate the embodiments of the present invention and together with the description, serve to explain the principles of the invention. In the drawings:

Figure 1 illustrates an isometric view of a first embodiment of the present invention with a roller accumulator buffer;

Figure 2 illustrates a detailed view of the roller accumulator buffer;

Figure 3 illustrates a side view of the first embodiment;

Figure 4 illustrates the path shielding in a side view of the roller accumulator buffer;

Figure 5 illustrates a side view of the a second embodiment of the present invention with a bucket accumulator buffer;

Figure 6 illustrates a detailed view of the bucket accumulator buffer;

Figure 7A illustrates a side view of a third embodiment of the present invention;

Figure 7B illustrates a plan view of a linear accumulator buffer;

Figure 8A illustrates an isometric view of the first embodiment with all shielding;

Figure 8B illustrates a plan view of a roller accumulator buffer;

Figure 9 illustrates a schematic of the controller system; and

Figure 10 illustrates a magazine dispenser for the packaging system.

Detailed Description of the Preferred Embodiments

Referring to the accompanying drawings in which like reference numbers indicate like elements, Figure 1 illustrates the packaging machine 10 of the present invention. Machine 10 comprises a container forming station 12, a product loading station 14, a sealing station 16, a separating station 18 and a conveyor 20. It should be appreciated that while the present invention is described with reference to a packaging machine that can draw a vacuum, it is not necessarily limited to only those in-line form-fill-seal packaging machines with this vacuum capability. The present invention can be used with any type of in-line form-fill-seal packaging machine, including those which use a magazine to load packages onto a conveyor. Additionally, the packaging may be evacuated or be partially filled with an inert gas, air or some other medium or material, possibly even a liquid.

Conveyor 20 moves incrementally at spaced intervals along the length of the machine 10. Preferably, conveyor 20 includes a track having compartments 22 of a size to receive the bottom surface of the containers and an electric motor 24 or other prime mover for moving the compartments 22 along their path of travel. It is understood that other conveying means may prove workable to marshal the containers through the stations and are therefore within the scope of the invention.

The machine 10 includes a lower film web supply roll 26 disposed at one end of machine 10. The lower film web 28 dispensed from roll 26 comprises a thermoformable and heat sealable packaging material of a type well known to those skilled in the art. Roll 26 is preferably rotatably mounted on an axle 30 disposed in a horizontal plane.

The container forming station 12 includes a plurality of molds 32 generally in the shape of the product container. A heating element 34 is positioned above molds 32 and overlies the lower web film 28, which is indexed by conveyor 20 into the forming station 12. Mold 32 is

defined within container forming die 36 which underlies the heating element 34 and the lower film web 28. A duct 38 is disposed within the forming die 36 and connects mold 32 to a vacuum system 40. An optional vacuum system 40 is adapted to create negative pressure, thereby removing air from the mold 32, and positive pressure, thereby filling mold 32 with pressurized air. Station 12 forms a unit 42 comprising a plurality of packages or containers 44. The unit 42 normally comprises two containers 44 but may include more than two. The containers 44 include sidewalls 46, a bottom 48 and a flat outwardly projecting rim 50. It is understood, however, that any configuration of container 44 may be operable with the-present invention.

Product 52 is introduced into the containers 44 at the product loading station 14. Product 52 may be loaded by mechanical means, such as shown in Figure 5, or manually as product 52 characteristics require. It suffices that any loading means suitable to introduce product 52 into containers 44 is contemplated by the present invention.

Containers 44 holding product 52 are vacuum sealed at the sealing station 16. Sealing station 16 is adapted to simultaneously seal at least two units 42 of containers 44. Sealing station 16 includes a sealing die 54 underlying a thermosealing element 56 and an upper film supply roll 58 holding upper film web 59. Die 54 has at least one evacuation duct 60 connected to vacuum system 40 or, in the alternative, to a separate vacuum system (not shown).

The sealed containers 44 of the unit 42 are detached into individual containers at the separating station 18. At the separating station unit 42 is separated into individual containers 44 by a mechanical knife (not shown) or other suitable separating means.

The control circuit of machine 10 is shown in Figure 9 in schematic form and is represented by the numeral 62. In its most simplified form, the control circuit 62 includes start/stop switch 64, a controller 66 and appropriate leads 68 between the controller 66 and the

conveyor motor 24 and start/stop switch 64. Control leads 68 also extend from the controller 66 to container forming station 12, product loading station 14, vacuum system 40, sealing station 16 and separating station 18. It is to be understood that the controller 66 may be a hard-wired logic circuit, a microprocessor or other equivalent means for activating and deactivating the stations described above. Preferably, controller 66 comprises a microprocessor which has been preprogrammed to index conveyor 20 along spaced intervals and to activate and deactivate the various stations at predetermined times.

In operation, conveyor 20 is activated by controller 66 indexing lower film web 28 from right to left when viewing Figure 5. As web 28 passes the container forming station 12, the controller 66 will momentarily stop the conveyor 20. Container forming die 36 is then raised under the heating element 34 thereby creating a seal between the heating element 34, the lower web 28 and the die 36. Pressurized air or other gas is forced into the die 36 through duct 38 by vacuum system 40 causing the lower film web 28 to contact the heating element 34. Once the lower film web 28 has been heated to become sufficiently formable, vacuum is applied to the die 36 through duct 38 causing the web 28 to be drawn into the product container molds 32 wherein web 28 is conformed into the shape of the molds 32. Die 36 then lowers from the heating element 34 and the formed unit 42 of containers 44 is indexed by the conveyor 20 to the product loading station 14.

At the product loading station 14, product is introduced into the individual containers 44 of the unit 42 by mechanical or manual means after every index of conveyor 20. Once loaded, the unit 42 of containers 44 is indexed by the conveyor 20 to the sealing station 16.

After every other index of the conveyor 20, controller 66 activates the sealing station 14. It is to be understood, however, that where sealing die 54 is adapted to vacuum seal more than two units 42 of containers 44, controller 66 would activate sealing station 14 only after the

corresponding number of indices. For example, if die 54 is adapted to vacuum seal four units 42 of containers 44, controller would activate the sealing station 16 after every fourth index of conveyor 20.

Upon activation, die 54 is raised to the thermosealing element 56 thereby creating an airtight seal between the sealing die 54, the upper film web 59 and the thermosealing element 56. In closed position, an evacuation chamber 50 is formed by the sealing die 54. Vacuum system 40 is activated to evacuate air from chamber 50 through evacuation ducts 60, thereby creating negative pressure within the chamber 50. When the desired degree of evacuation is reached, the thermosealing element 56 is lowered onto the upper film web 59 depressing the web 59 onto the rims 50 of containers 44. The thermosealing element 56 hermetically seals the web 59 to the rims 50. When the seal is complete, thermosealing element 56 is raised from the sealed containers 44 and the sealing die 54 is vented through evacuation ducts 60. Sealing die 54 is then lowered. The controller 66 then causes the sealed containers 44 to be advanced by the conveyor 20 to the separating station 18 where units 42 are separated into individual containers 44.

If circumstances require, inert gas may be back-flushed into the chamber 50 during the sealing phase. More particularly, modified atmosphere may be injected into the chamber 50 after it has been evacuated but before the thermosealing element 56 has been applied to the upper web 59. The effect of back-flushing is to fill the containers 44 with a gas that does not present the problems of contamination and spoilage associated in ambient air. Back-flushing is also advantageous to prevent the container 44 from crushing or compressing delicate product once the sealing die 54 is vented.

An alternative embodiment of the present invention is illustrated in FIG. 10 and is designated by the numeral 110. In this embodiment, machine 110 utilizes a different form of

container forming station 112. The containers 144 of machine 110 are preformed and preferably stored in an upright magazine 170 above the conveyor 120. The preformed containers 144 are dispensed, either individually or in multi-container units, onto the conveyor 120 in response to controller 66. Once dispensed onto conveyor 120, containers 144 are filled with product, vacuum sealed and separated in substantially the same manner as described in connection with the preferred embodiment.

US Pat. No. 5,685,130 describes a queuing operation in which a steady flow of incoming packages is buffered for the index conveyor. In the present invention, a controller matches the cyclical rate of the index conveyor for packaging operations with the steady rate of the continuous speed conveyor for biological treatment/irradiation operations and uses a buffer to transition from the cyclical rate to the steady rate. The present system has an index conveyor with a filling station and a packaging station. Discrete packages are filled with the stream of products, sealed and moved on an index conveyor. The system moves the discrete packages an irradiation chamber at a steady rate on a continuous speed conveyor. A controller matches the cyclical rate of the index conveyor with the steady rate of the continuous speed conveyor and uses a buffer to transition from the cyclical rate to the steady rate.

The object of this invention is to provide a means to irradiation treat materials or products while they are still captive in the cycle of the form fill and seal packaging process. In order to accomplish this new configuration design for the integrated accelerator and radiation shielding needed to be realized. Additional to this a very important aspect of the product transport method needed to be realized.

This last requirement specifically refers to the standard material movement in a form fill and seal packaging system which moves or indexes the product in an intermittent motion. This intermittent motion allows for both the "form" of the receptor or tray, the "fill" of the product

into that formed tray and eventually the cutting of the package array into individual item size at the end of the process. Contrary to this the requirements for the uniform delivery of the electron beam or the X-ray energy to such a material requires that the product move or is conveyed in a very smooth and continuous motion, at a speed which is proportional to the electron or photon fluence in order to deliver the appropriate dose to the material. This requirement uniform dose is known and accepted in the industry and referred to in many patents today.

In a form fill and seal packaging system the materials and products are typically conveyed in a linear fashion in one plane. This flat plane makes it very easy to load and package the products since gravity is working with you. This configuration also holds the product horizontal until they are cut into individual packages and exit the system. One aspect of this new invention is in the design of a roller to allow the "bending" of the packaged product line to pass this material into and out of the radiation shielding enclosure. Since this type of packaging system provides a configuration in a linear array with repeatable spacing between product rows the packaged product line could only be "bent" in these spaces. This length of the package that cannot be bent is determined by the product loaded into the package itself. The bending of the packaged product is accomplished on a hollow roller that has essentially only supporting structures to hold the product on the packaging material between where the product is loaded. This bending then allows the product to be conveyed in a circuitous path allowing product entry to the shield and limiting radiation leakage from the shield.

Another aspect of this new invention is a method for the translation of this intermittent motion of the form fill and seal packaging system into a continuous motion required in the electron or x-ray dose delivery. This is accomplished by the design of roller or accumulator devices placed in the line which dampen and effectively remove the intermittent motion of the product web. This accumulator/roller slides freely on a shaft which can be tensioned by

mechanical means or simply provide tension through gravity. This accumulator/roller is positioned between the intermittent control of the packaging system and the continuous speed underbeam system. This accumulator, along with a variable speed drive mechanism which positively controls the speed of the web while it is subjected to the irradiation energy, effectively accomplishes this product speed translation from intermittent to continuous. The packaging system continues to operate with the intermittent motion that is required for its process while the material is then smoothly conveyed for the irradiation process. This accumulator/roller device may also be used after the material has been irradiation processed to translate this smooth motion back to intermittent if this is required subsequently in the process.

Detailed drawing describing this accumulator device and the drive mechanism for the "underbeam" speed control is seen in the drawings included. This section of the product transport system can be installed in the product line before the "cut" of the product into individual packages. This then allows a means for positively moving a single layer of many products through an electron beam or x-ray irradiation system easily, effectively and provides a means to control the speed, thus the irradiation dose that the product receives.

Another method for accumulation of the material may simply be accomplished by providing a series of rollers which allow the material to "hang" in the radiation shielding labyrinth entrance in sufficient length to bend around the shielding material.

The conveyance of the product in this for also allows for easier movement of the product or material into and out of the irradiation shield or chamber. Since one of the primary design issues with these type system is to allow for product entrance and exit from the shield while at the same time effectively trapping or reducing the x-ray energy leaking from the shield. The conveyance of products in this type of low profile format minimizes the x-ray leakage and therefore allows for the shielding to be designed in a more compact and economical manner.

In this process it is important to be able to correlate the dose delivered to a particular product for the purpose of process certification. This provides the user with the means of tracability for processing food stuffs, medical product sterilization and overall process control. The integration of these two processing systems (irradiation and packing) which includes the parameters from the irradiation system and the tracking of individual products in the packaging system permits strict control requirements such as those in product sterility processing. This provides a means for process control and validation of the product coming off the packaging system for individual products that is not done today in irradiation processing. By providing specific signals for beam intensity, beam scanning distribution, energy stability etc, to the packaging system PLC this tracability of sterility can easily be accomplished.

Irradiation processing of materials, specifically electron beam irradiation processing of materials, which are done in the format detailed above are typically described as having been "single sided processed". This term, as it is used in the industry, refers to the fact the electron beam is delivered to the product from one direction only and the product has not been "flipped over" or treated from the opposite side with electrons, i.e., "single sided processing". The limitation in this style of one sided treatment is that the energy of the electron must then be sufficiently high to penetrate the product being treated to effectively treat the "whole" product from this single side delivery of electrons. This requirement for the higher energy accelerator means that more radiation shielding must be used to limit the x-ray leakage which increases the overall system cost. One embodiment of this invention is to utilize a high energy, low power accelerator to treat the irradiated product in the manner described above with sufficient energy to treat the whole product.

When material and product densities are sufficiently low the energy of the accelerator may be reduced to a minimum level to allow for reduced size, radiation shielding and power

requirements.

One might imagine that if there was a means for delivering the electrons from a single side in a manner to more effectively distribute the electron energy in the product and not require the typical increase in the system energy that a more cost effective and smaller system could be produced. One means for accomplishing this is to provide reflector plates in the beam chamber around the exit of the scanner which are positioned to deflect a portion of the electron beam and low energy scatter electrons into the material. These deflected or reflected electrons enter the material from wide angles and provide dose increases around the edges of the product being treated. This effect can improve the dose distribution and irradiation process uniformity.

Radiation dosimetry is the typical method for qualifying whether a particular product has been properly treated. One unique concept for this type of system, where the label for each package is individually printed after the package has been sealed and before it has been irradiated, is to use radiation sensitive inks for a portion of the label. This radiation sensitive ink will change color during the irradiation process and be a clear indicator that the package has been treated. This may or may not be utilized in the quality control process for assurance of product treatment.

An example of one type of accelerator that may be used in this application is the DC, Dynamitron system described here, works on a similar principle as a television tube. Free electrons are generated by heating a filament which is part of the electron gun assembly. A high voltage of the correct polarity draws the electrons away from the gun and accelerates them through the vacuum tube. The electrons gain energy and velocity as they are accelerated in the vacuum tube. As the beam of electrons passes from this acceleration or beam tube, they travel down a vacuum beam line and may pass through the scan magnet or other types of beam distribution devices which are known in the art. This magnet, and its oscillating magnetic field,

sweeps the beam back and forth across the scan window. At the scan window the electrons pass from the vacuum chamber into the air where they are delivered directly to the product or to an x-ray converter to provide photons for x-ray processing

Electron beam system for this type of process range from low voltages in the 100's of kV range up to accelerators that deliver electrons to 10 or more mega volts. Electrons accelerated to an energy of 5 MeV are traveling at approximately 99.6% of the speed of light, or nearly 300,000 km/sec, when they enter the product. The amount of beam current, which partially determines the processing rate is measure in mirco or millamperes.s It is interesting to note that 1 mA of beam current represents about 6 million billion electron particles every second.

Where the objective of the electrons generated in a television is to create a picture, a Dynamitron bundles electrons into a 3 to 5 cm diameter beam to irradiate materials. The enormous number of electrons and the high acceleration voltage produces rapid reactions by operating directly on the molecules within the product. This produces an efficiency that is outstanding when compared with other methods such as heat, light, and chemical reagents.

There are many different type of accelerators available to provide this type of processing capability, to one skilled in the art of electron beam system this would be understood. The Dynamitron described here is but one example, but other types of AC accelerators such as multiple and single cavity Linac's, single cavity multi-pass Rhodotrons or DC ICT's (Insulated Core Transformers) or single gap DC accelerators may be used.

In view of the foregoing, it will be seen that the several advantages of the invention are achieved and attained.

The embodiments were chosen and described in order to best explain the principles of the invention and its practical application to thereby enable others skilled in the art to best

utilize the invention in various embodiments and with various modifications as are suited to the particular use contemplated.

As various modifications could be made in the constructions and methods herein described and illustrated without departing from the scope of the invention, it is intended that all matter contained in the foregoing description or shown in the accompanying drawings shall be interpreted as illustrative rather than limiting. For example, while the present invention discusses the details of an electron beam device for the sterilization process, other forms of electromagnetic sterilization may be used. Also, while an active beam scanner is described, it will also be appreciated that other devices to distribute the beam in the target region can be used, such as a diffuser. Thus, the breadth and scope of the present invention should not be limited by any of the above-described exemplary embodiments, but should be defined only in accordance with the following claims appended hereto and their equivalents.

What is Claimed Is:

1. A packaging and biological treatment system for a stream of products comprising:

means for conveying the stream of products;

means for sequentially enclosing the products into a plurality of discrete packages, wherein said discrete packages are enclosed and connected by a web enclosure; and

means for routing said discrete packages through a irradiation chamber via a circuitous path while said discrete packages remain connected by said web enclosure.

2. The packaging and biological treatment system of claim 1, wherein said conveying means is comprised of a package forming station where a packaging material web is molded into an array of packages, a product filling station where the stream of products is deposited onto said array of packages, and a conveyor operatively connecting said package forming station and said product filling station with said enclosing means.

3. The packaging and biological treatment system of claim 1, wherein said enclosing means is comprised of a sealing station having a web enclosure supply roll, a sealing die, and a thermosealing element in operative communication with said web enclosure and overlying said sealing die.

4. The packaging and biological treatment system of claim 1, wherein said routing means comprises an entry region, a buffer region, and an exit region, wherein said buffer region selected from the group of buffers consisting of an bucket accumulator, a roller accumulator and a slackening trough.

5. The packaging and biological treatment system of claim 4, wherein said irradiation chamber further comprises a beam generator, a beam distributor, a target region, a beam generator shield, a target region shield, and a serpentine shield, wherein said serpentine

shield surrounds said circuitous path from said entry region to said target region and from said target region to said exit region.

6. The packaging and biological treatment system of claim 1, wherein said conveying means further comprises an index conveyor wherein said discrete packages are moved from a first position to a second position in a series of spaced intervals having a cyclical rate and wherein said routing means comprises a continuous speed conveyor wherein said discrete packages move through said irradiation chamber at a steady rate.

7. The packaging and biological treatment system of claim 6, further comprising a controller for matching said cyclical rate of said index conveyor with said steady rate of said continuous speed conveyor.

8. The packaging and biological treatment system of claim 1, further comprising a serpentine shield surrounding said circuitous path, said circuitous path comprising an entry point, an exit point, a substantially straight path within said irradiation chamber, a first arcuate path between said entry point and said substantially straight path and a second arcuate path between said substantially straight path and said exit point.

9. The packaging and biological treatment system of claim 1, further comprising a separating station wherein said web between said connected discrete packages is cut to form a set of disconnected packages.

10. The packaging and biological treatment system of claim 1 wherein said discrete packages traverse said irradiation chamber in a single layer array.

11. A packaging and biological treatment system for a stream of products comprising:

means for conveying the stream of products from a first position to a second position in a series of spaced intervals having a cyclical rate;

means for sequentially enclosing the products into a plurality of discrete packages during said series of spaced intervals, wherein said discrete packages are enclosed and connected by a web enclosure;

means for routing said discrete packages through a irradiation chamber at a steady rate; and

means for matching said cyclical rate of said conveying means with said steady rate of said routing means.

12. The packaging and biological treatment system of claim 11, wherein said web enclosure connects said discrete packages within said irradiation chamber.

13. The packaging and biological treatment system of claim 11, wherein said discrete packages are disconnected from said web enclosure within said irradiation chamber.

14. The packaging and biological treatment system of claim 11, wherein said conveying means is comprised of a package forming station where a packaging material web is molded into an array of packages, a product filling station where the stream of products is deposited onto said array of packages, and an indexed conveyor operatively connecting said package forming station and said product filling station with said enclosing means.

15. The packaging and biological treatment system of claim 11, wherein said enclosing means is comprised of a sealing station having a web enclosure supply roll, a sealing die, and a thermosealing element in operative communication with said web enclosure and overlying said sealing die.

16. The packaging and biological treatment system of claim 11, wherein said routing means comprises an entry, a buffer, and an exit, and wherein said matching means comprises a controller.

17. The packaging and biological treatment system of claim 16, wherein said buffer

is further comprised of a circuitous path between said entry and said exit.

18. The packaging and biological treatment system of claim 17, wherein said irradiation chamber further comprises a beam generator, a beam distributor, a target region, a beam generator shield, a target region shield, and a serpentine shield, wherein said serpentine shield surrounds said circuitous path from said entry to said target region and from said target region to said exit.

19. The packaging and biological treatment system of claim 18, wherein said serpentine shield further comprises a substantially straight path within said irradiation chamber, a first arcuate path between said entry and said substantially straight path and a second arcuate path between said substantially straight path and said exit.

20. The packaging and biological treatment system of claim 16, wherein said buffer further comprises a separating station wherein said web between said connected discrete packages is cut to form a set of packages disconnected from said web enclosure, said buffer receiving said discrete packages at said entry with said cyclical rate of said conveying means and passing said set of disconnected packages at said exit to said irradiation chamber.

21. The packaging and biological treatment system of claim 19, wherein said irradiation chamber further comprises a beam generator, a beam distributor, an entry region, an exit region, a target region between said entry region and said exit region, a beam generator shield, a target region shield, and a pair of shutter shields, wherein said shutter shields open for a first period of time while a treated set of packages exit said irradiation chamber from said exit region and an unsterile set of packages enter said irradiation chamber, and wherein said shutter shields close for a second period of time while said unsterile set of packages are moved from said entry region through said target region to said exit region.

22. The packaging and biological treatment system of claim 11, further comprising a

serpentine shield surrounding said routing means, said serpentine shield comprising an entry point, an exit point, a substantially straight path within said irradiation chamber, a first arcuate path between said entry point and said substantially straight path and a second arcuate path between said substantially straight path and said exit point.

23. A packaging and biological treatment system for a stream of products comprising:

an index conveyor comprising a filling station and a packaging station, wherein a plurality of discrete packages are filled with the stream of products, sealed and moved from a first position to a second position in a series of spaced intervals having a cyclical rate;

a irradiation chamber;

a continuous speed conveyor wherein said discrete packages are moved through said irradiation chamber at a steady rate;

a buffer wherein a set of said discrete packages moving at said cyclical rate are transitioned to said steady rate; and

a controller matching said cyclical rate of said index conveyor with said steady rate of said continuous speed conveyor.

24. The packaging and biological treatment system of claim 23, wherein said web enclosure connects said discrete packages within said irradiation chamber.

25. The packaging and biological treatment system of claim 23, wherein said discrete packages are disconnected from said web enclosure within said irradiation chamber.

26. The packaging and biological treatment system of claim 23, wherein said routing means comprises an entry region, a buffer region, and an exit region, wherein said buffer region selected from the group of buffers consisting of a linear accumulator, a roller accumulator, a bucket accumulator, and a slackening trough.

27. The packaging and biological treatment system of claim 23, wherein said routing means comprises an entry, a buffer, and an exit.

28. The packaging and biological treatment system of claim 27, wherein said buffer is further comprised of a circuitous path between said entry and said exit.

29. The packaging and biological treatment system of claim 28, wherein said irradiation chamber further comprises a beam generator, a beam distributor, a target region, a beam generator shield, a target region shield, and a serpentine shield, wherein said serpentine shield surrounds said circuitous path from said entry to said target region and from said target region to said exit.

30. The packaging and biological treatment system of claim 29, wherein said serpentine shield further comprises a substantially straight path within said irradiation chamber, a first arcuate path between said entry and said substantially straight path and a second arcuate path between said substantially straight path and said exit.

31. The packaging and biological treatment system of claim 27, wherein said buffer further comprises a separating station wherein said web between said connected discrete packages is cut to form a set of packages disconnected from said web enclosure, said buffer receiving said discrete packages at said entry with said cyclical rate of said conveying means and passing said set of disconnected packages at said exit to said irradiation chamber.

32. The packaging and biological treatment system of claim 31, wherein said irradiation chamber further comprises a beam generator, a beam distributor, an entry region, an exit region, a target region between said entry region and said exit region, a beam generator shield, a target region shield, and a pair of shutter shields, wherein said shutter shields open for a first period of time while a treated set of packages exit said irradiation chamber from said exit region and an untreated set of packages enter said irradiation chamber, and wherein said shutter

shields close for a second period of time while said untreated set of packages are moved from said entry region through said target region to said exit region.

33. The packaging and biological treatment system of claim 23, further comprising a radiation sensitive label on each of said discrete packages.

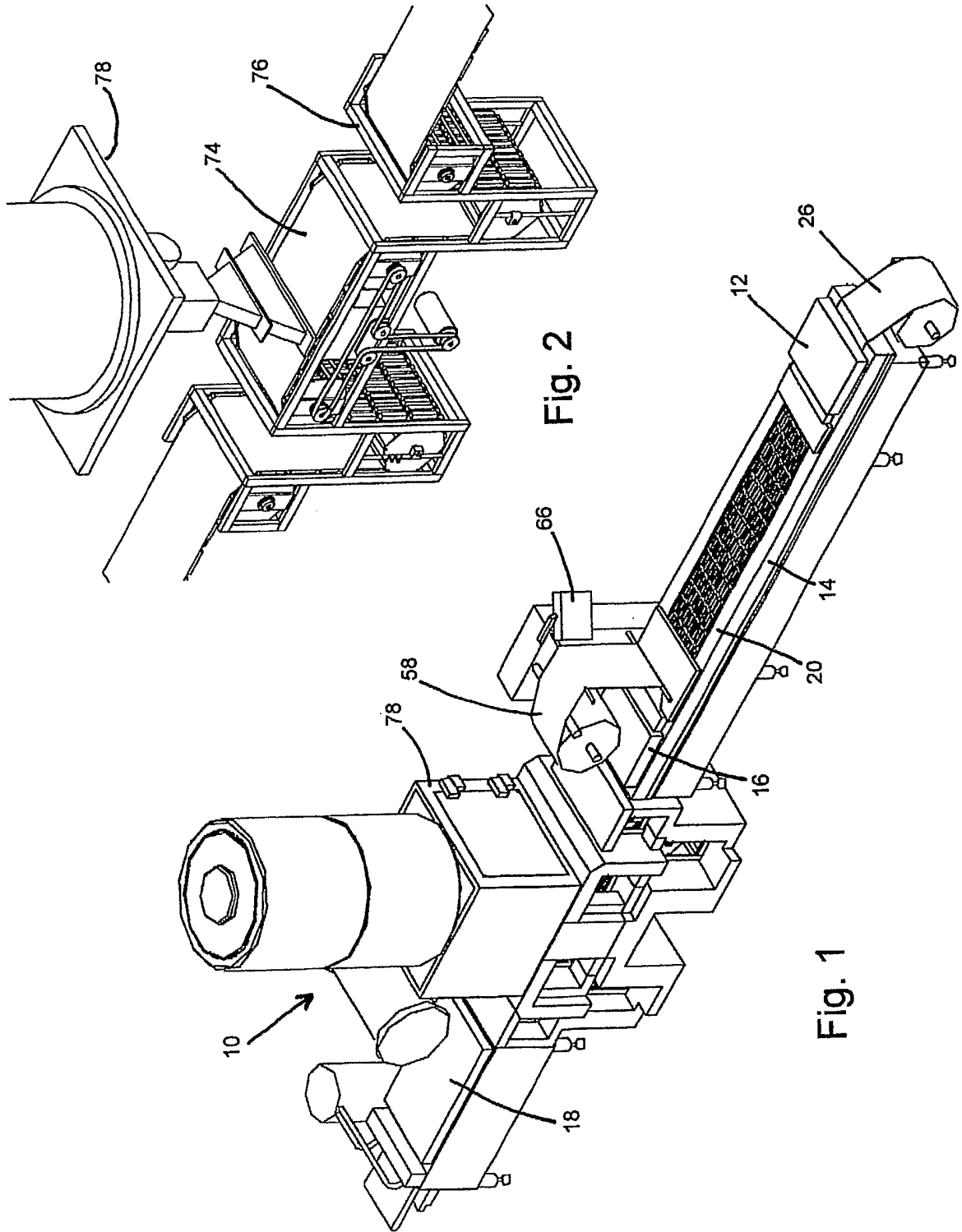
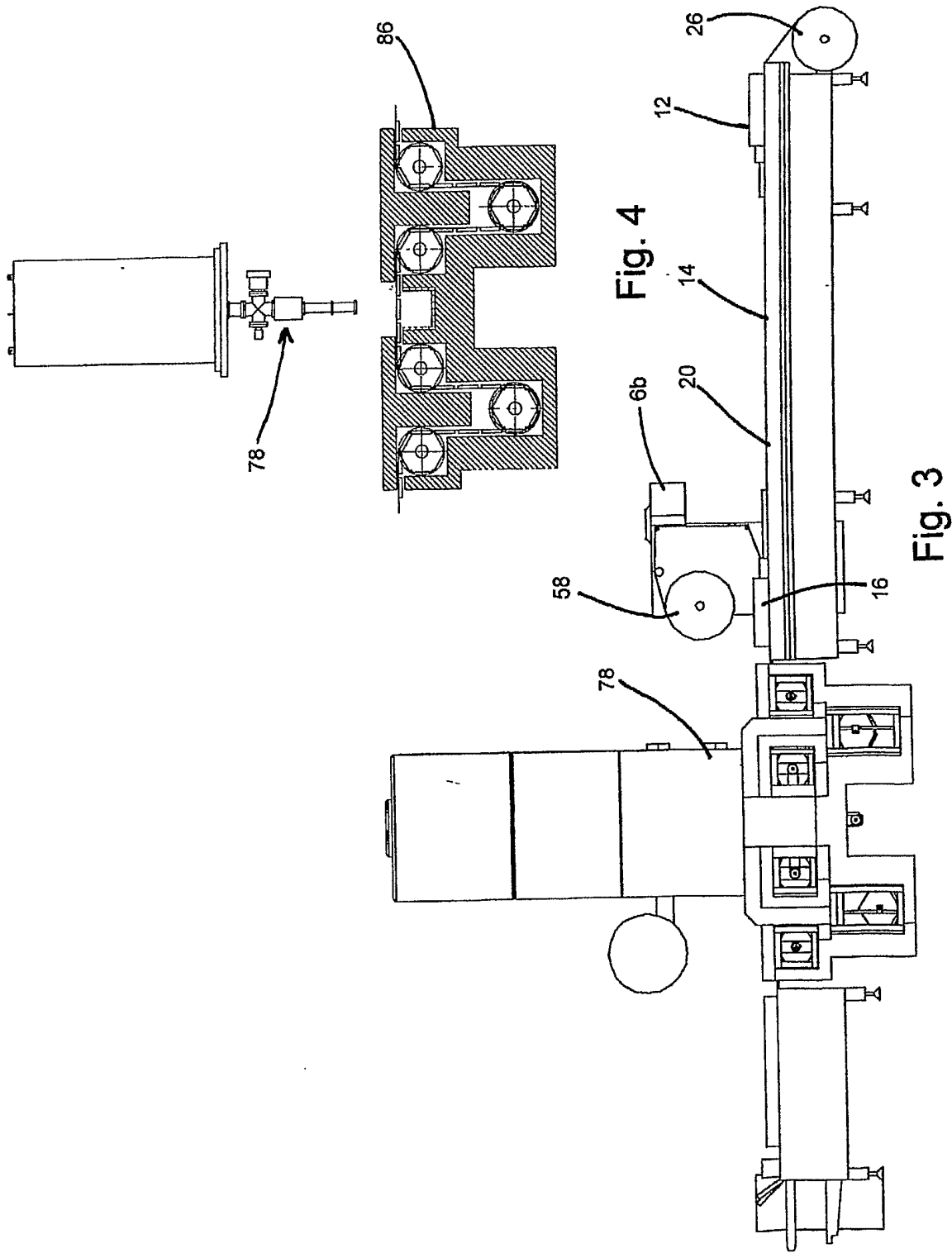

Fig. 2

Fig. 1



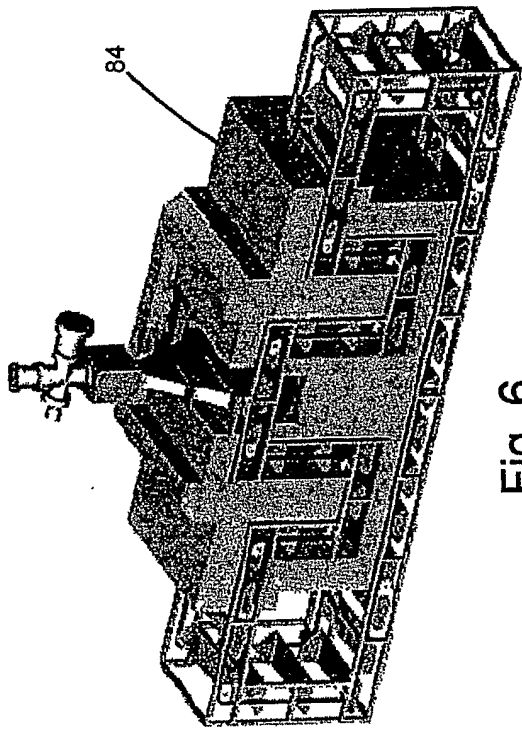

Fig. 6

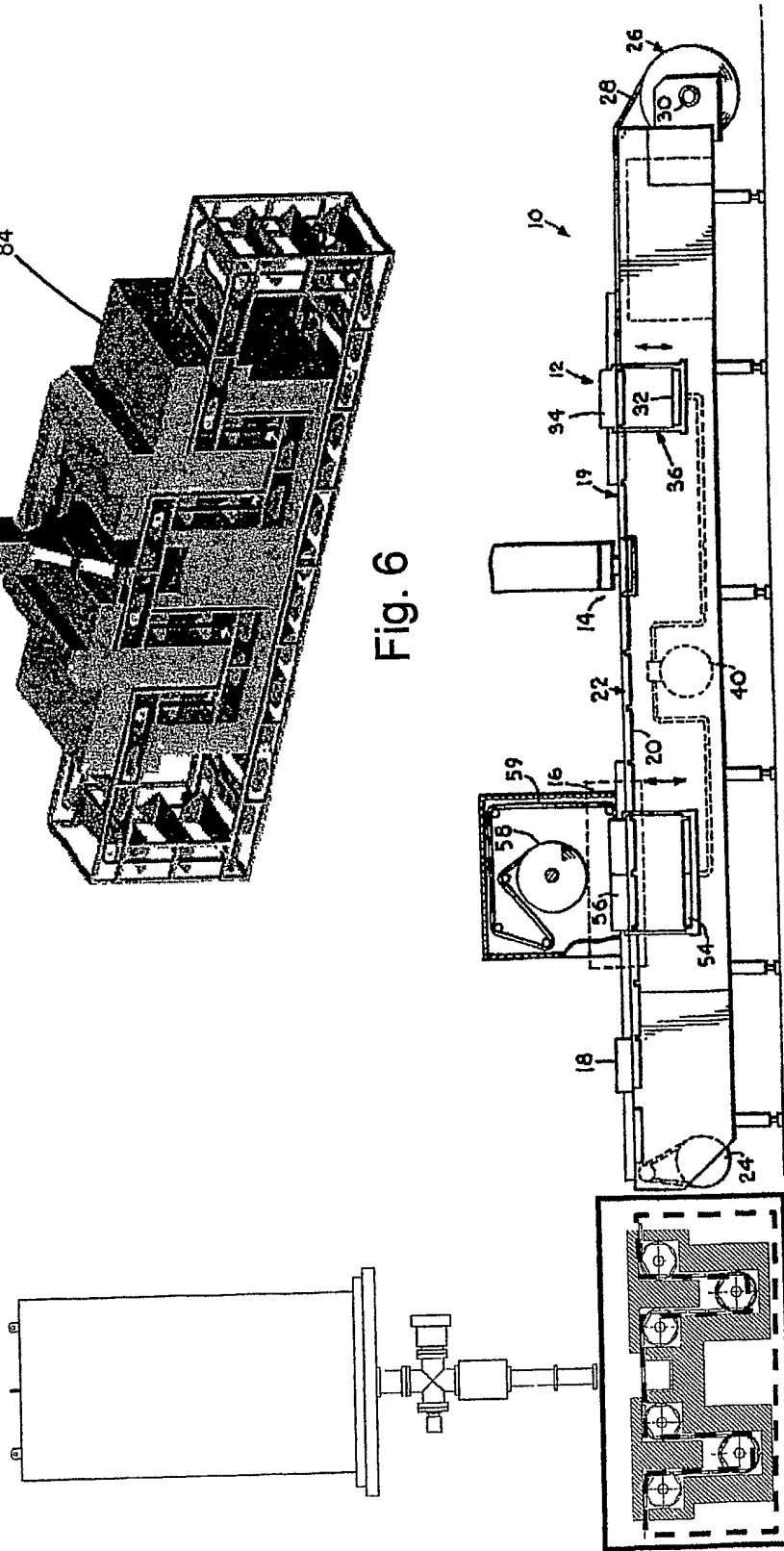

Fig. 5

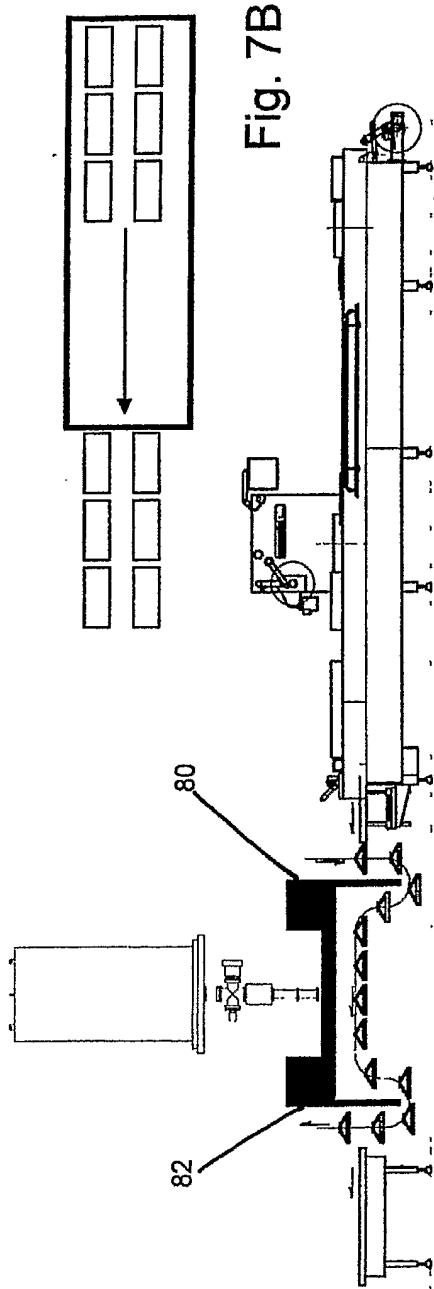

Fig. 7B

Fig. 7A

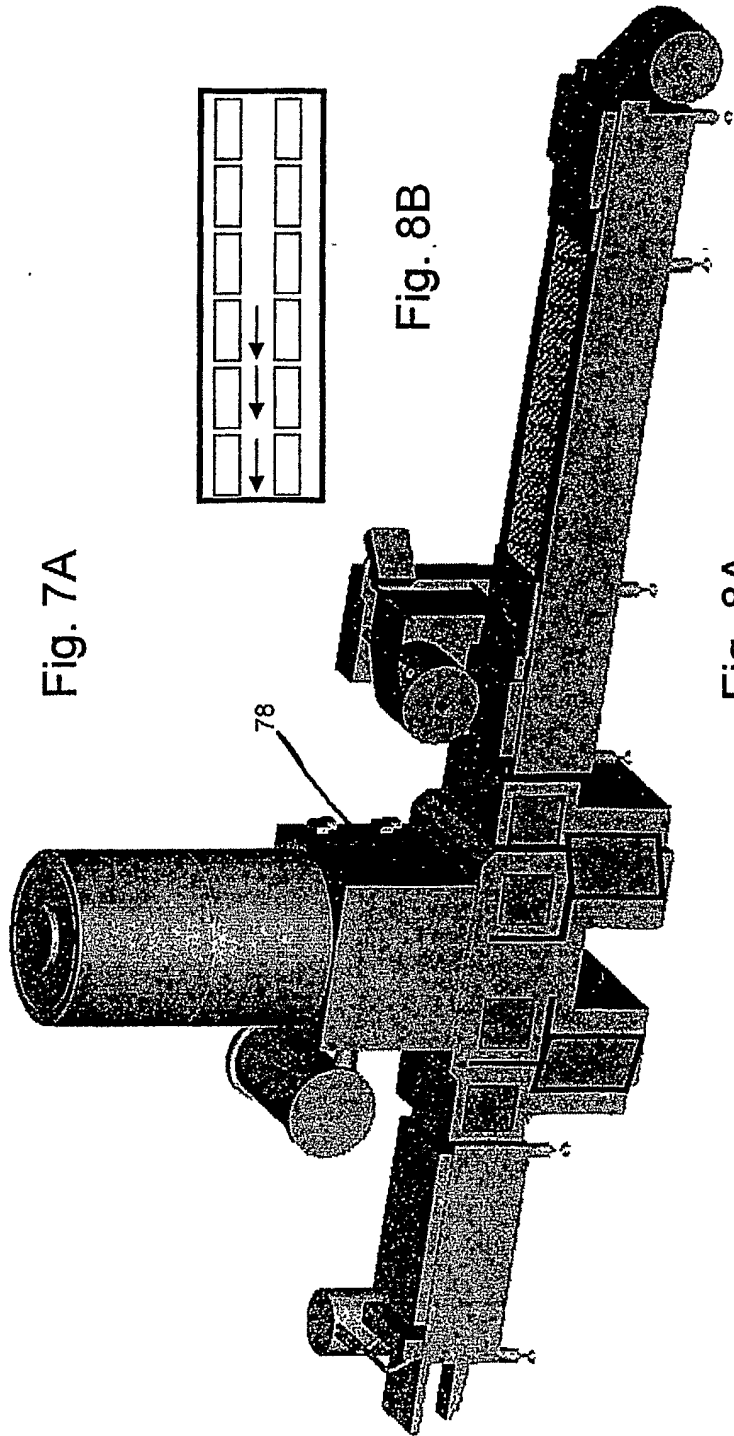

Fig. 8B

Fig. 8A

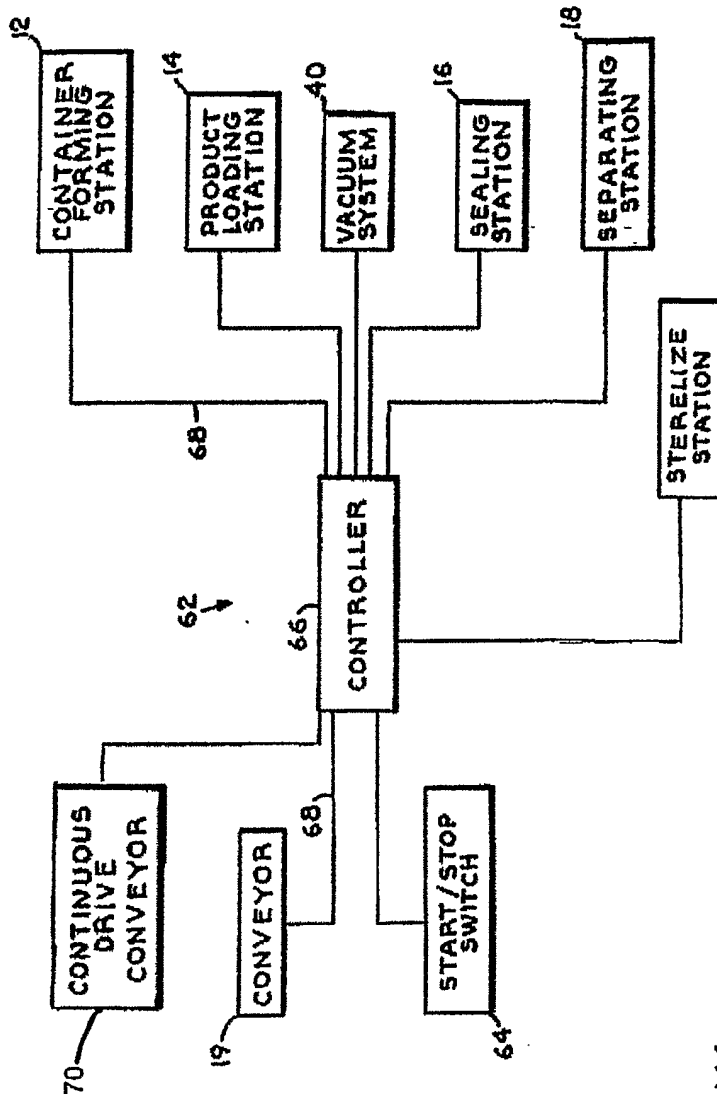

Fig. 9

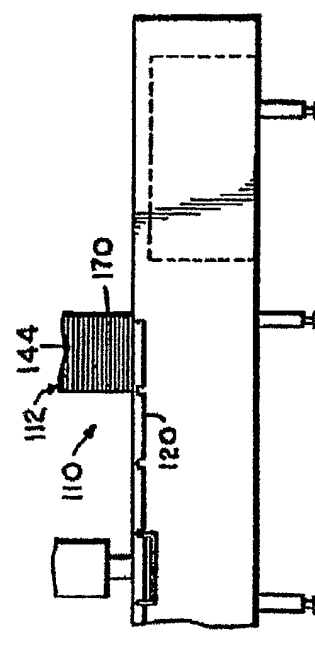

Fig. 10