

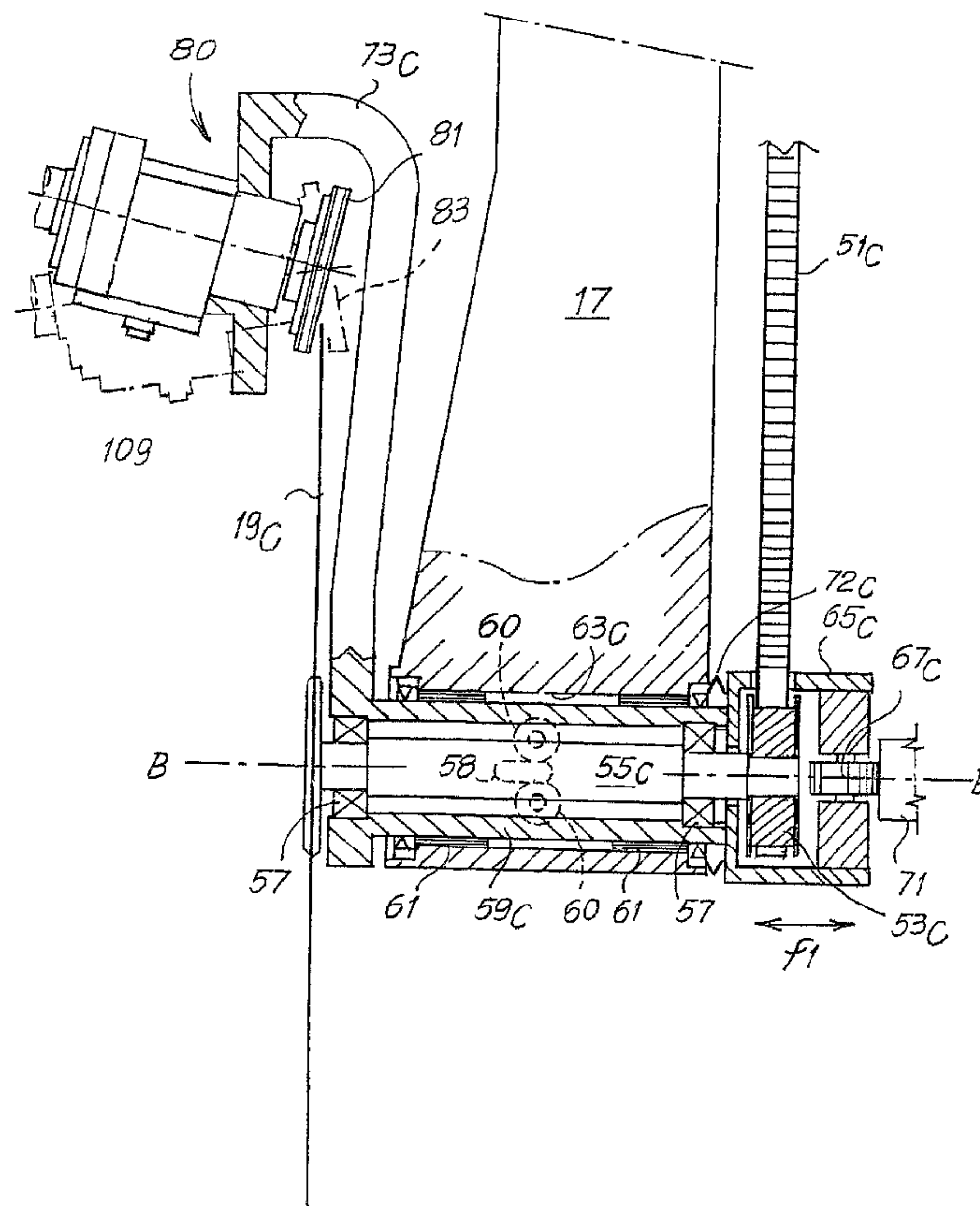

(86) Date de dépôt PCT/PCT Filing Date: 2003/10/15
 (87) Date publication PCT/PCT Publication Date: 2004/04/29
 (45) Date de délivrance/Issue Date: 2011/04/05
 (85) Entrée phase nationale/National Entry: 2005/04/04
 (86) N° demande PCT/PCT Application No.: IT 2003/000631
 (87) N° publication PCT/PCT Publication No.: 2004/035273
 (30) Priorité/Priority: 2002/10/18 (IT FI2002A000197)

(51) Cl.Int./Int.Cl. *B26D 7/12* (2006.01),
B24B 3/36 (2006.01), *B24B 3/46* (2006.01),
B26D 1/00 (2006.01), *B26D 3/16* (2006.01)
 (72) Inventeurs/Inventors:
 CHIOCCHETTI, MARIO GIONI, IT;
 GELLI, MAURO, IT;
 RIDOLFI, QUIRINO FERNANDO, IT
 (73) Propriétaire/Owner:
 FABIO PERINI S.P.A., IT
 (74) Agent: RIDOUT & MAYBEE LLP

(54) Titre : MACHINE DE COUPE EQUIPEE D'UN UNITE D'AFFUTAGE POUR UNE LAME, PROCEDE D'AFFUTAGE
 ET LAME POUR CETTE MACHINE
 (54) Title: CUTTING MACHINE WITH A SHARPENING UNIT FOR A BLADE, SHARPENING METHOD AND BLADE
 FOR SAID MACHINE



(57) Abrégé/Abstract:

The unit comprises a first grinding wheel (81) and a second grinding wheel (83) acting on a first side (207) and on a second side (209) of the bevel (205) of the blade (19). The first grinding wheel (81) has a finer grain than the second grinding wheel (83).



(57) **Abrégé(suite)/Abstract(continued):**

Moreover, the first grinding wheel also has an inclination that is not parallel to the respective first side (207) of the bevel (205) of the blade (19), while the second grinding wheel (83) has an inclination essentially parallel to the second side (209) of said bevel.

(12) INTERNATIONAL APPLICATION PUBLISHED UNDER THE PATENT COOPERATION TREATY (PCT)

(19) World Intellectual Property
Organization
International Bureau



(43) International Publication Date
29 April 2004 (29.04.2004)

PCT

(10) International Publication Number
WO 2004/035273 A1

(51) International Patent Classification⁷: **B26D 7/12**,
3/16, B24B 3/36

(21) International Application Number:
PCT/IT2003/000631

(22) International Filing Date: 15 October 2003 (15.10.2003)

(25) Filing Language: Italian

(26) Publication Language: English

(30) Priority Data:
FI2002A000197 18 October 2002 (18.10.2002) IT

(71) Applicant (for all designated States except US): **FABIO PERINI S.P.A.** [IT/IT]; Zona Ind.le P.I.P. Mugnano Sud, I-55100 Lucca (IT).

(72) Inventors; and

(75) Inventors/Applicants (for US only): **CHIOCCHETTI**,

Mario, Gioni [IT/IT]; Via di Tiglio, 612, Pieve di Compito, I-55065 Capannori, Lucca (IT). **GELLI, Mauro** [IT/IT]; Via del Marginone 24, Fraz. Pieve S. Paolo, I-55066 Capannori, Lucca (IT). **RIDOLFI, Quirino, Fernando** [IT/IT]; Via di Tiglio 290, Fraz. Carraia, I-55061 Capannori, Lucca (IT).

(74) Agents: **MANNUCCI, Michele** et al.; Ufficio tecn. Ing A. Mannucci S.r.l., Via della Scala, 4, I-50123 Firenze (IT).

(81) Designated States (*national*): AE, AG, AL, AM, AT, AU, AZ, BA, BB, BG, BR, BY, BZ, CA, CH, CN, CO, CR, CU, CZ, DE, DK, DM, DZ, EC, EE, EG, ES, FI, GB, GD, GE, GH, GM, HR, HU, ID, IL, IN, IS, JP, KE, KG, KP, KR, KZ, LC, LK, LR, LS, LT, LU, LV, MA, MD, MG, MK, MN, MW, MX, MZ, NI, NO, NZ, OM, PG, PH, PL, PT, RO, RU, SC, SD, SE, SG, SK, SL, SY, TJ, TM, TN, TR, TT, TZ, UA, UG, US, UZ, VC, VN, YU, ZA, ZM, ZW.

(84) Designated States (*regional*): ARIPO patent (GH, GM, KE, LS, MW, MZ, SD, SL, SZ, TZ, UG, ZM, ZW),

[Continued on next page]

(54) Title: CUTTING MACHINE WITH A SHARPENING UNIT FOR A BLADE, SHARPENING METHOD AND BLADE FOR SAID MACHINE

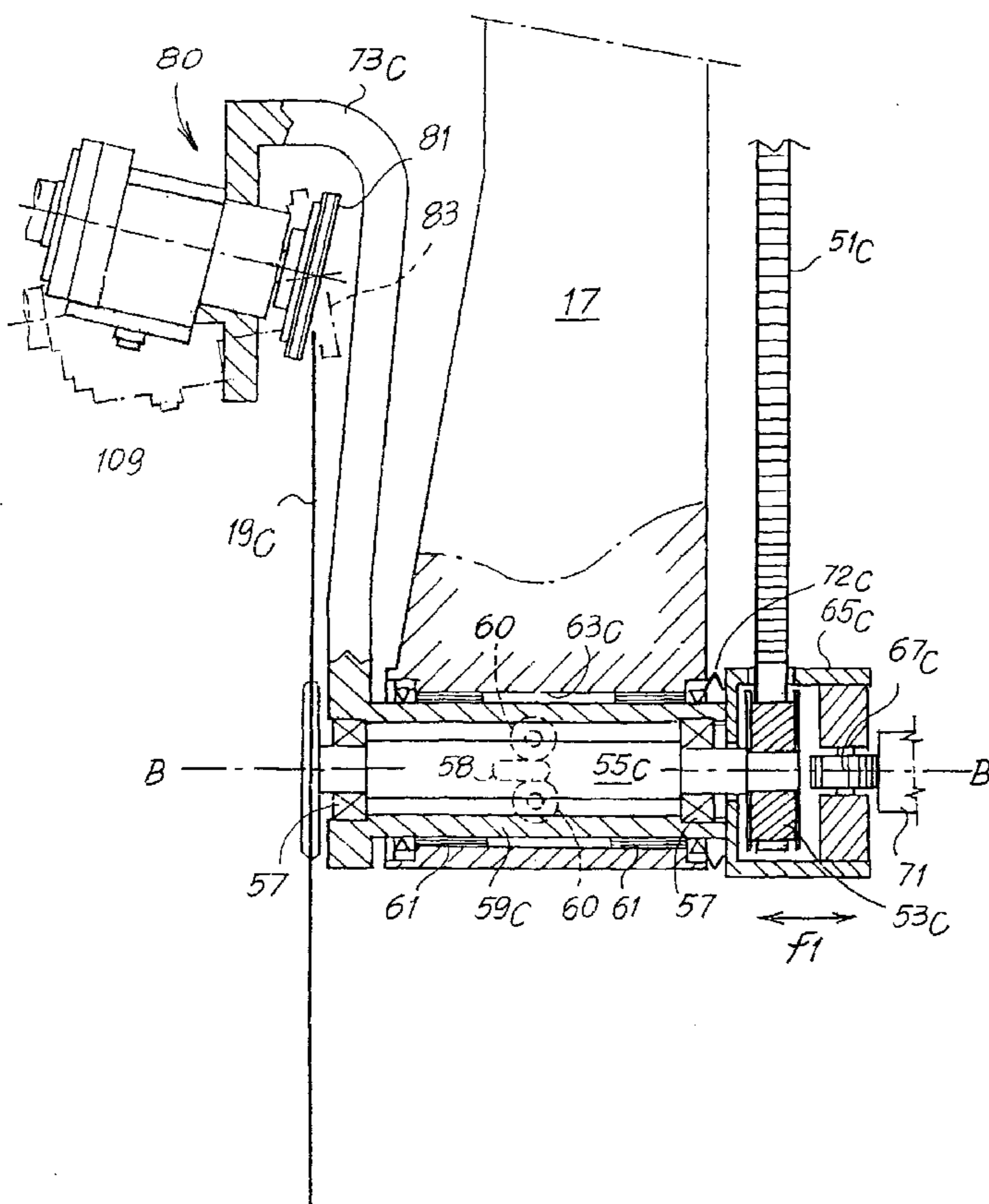

(57) Abstract: The unit comprises a first grinding wheel (81) and a second grinding wheel (83) acting on a first side (207) and on a second side (209) of the bevel (205) of the blade (19). The first grinding wheel (81) has a finer grain than the second grinding wheel (83). Moreover, the first grinding wheel also has an inclination that is not parallel to the respective first side (207) of the bevel (205) of the blade (19), while the second grinding wheel (83) has an inclination essentially parallel to the second side (209) of said bevel.

WO 2004/035273 A1

WO 2004/035273 A1



Eurasian patent (AM, AZ, BY, KG, KZ, MD, RU, TJ, TM),
European patent (AT, BE, BG, CH, CY, CZ, DE, DK, EE,
ES, FI, FR, GB, GR, HU, IE, IT, LU, MC, NL, PT, RO,
SE, SI, SK, TR), OAPI patent (BF, BJ, CF, CG, CI, CM,
GA, GN, GQ, GW, ML, MR, NE, SN, TD, TG).

Published:

— *with international search report*

— *before the expiration of the time limit for amending the claims and to be republished in the event of receipt of amendments*

For two-letter codes and other abbreviations, refer to the "Guidance Notes on Codes and Abbreviations" appearing at the beginning of each regular issue of the PCT Gazette.

Cutting machine with a sharpening unit for a blade, sharpening method and blade for said machine

Description

Technical Field

5 The present invention relates to a method to sharpen disk-shaped cutting blades with a continuous cutting edge, and in particular to sharpen disk-shaped blades destined to cut rolls of web material such as paper, tissue paper, toilet tissue, kitchen towel and the like.

 The present invention also relates to a sharpening unit for disk-shaped blades,
10 in particular for cutting machines destined to cut rolls of web material or the like, and cutting machines comprising said sharpening unit.

 Moreover, the invention relates to a blade particularly suitable to be used with the method of the present invention.

State of the Art

15 Cutting machines are commonly used in the paper converting industry to produce small rolls from logs of wound paper, which have an axial length which is a multiple of the axial length of the finished products, corresponding to the axial dimension of the reels of paper coming from paper mills.

 The cutting machines commonly used to cut logs of paper or other wound
20 web materials are provided with a unit rotating about an axis usually parallel to the direction of feed of the logs to be cut or slightly slanting in respect of it. These logs are fed along one or more channels parallel to one another to be subjected to the action of a rotating disk-shaped cutting blade carried by the rotating unit. The disk-shaped blade rotates about an axis in turn parallel to the direction of feed of the elongated products to be cut. Traditionally, machines of this type have intermittent or
25 continuous feed (with variable or constant speed) of the logs. Examples of cutting machines of this type are described in US-RE-30598, EP-B-0507750, US-A-3213731, EP-B-0609668, US-A-5315907.

 The disk-shaped cutting blades used for this purpose are usually biconical in
30 shape. That is, they are thicker in proximity to the axis and gradually decrease in thickness from the axis towards the edge. The cutting edge is formed of a bevel symmetrical in respect of the median plane orthogonal to the axis of the tool.

 The blade must be sharpened frequently to restore the cutting edge especially as it is produced with steels of limited hardness and toughness, such as high speed

steels. Pairs of grinding wheels, motorized or more frequently drawn by the movement of the tool, are used for sharpening; these act in an approximately symmetrical manner on the two sides of the cutting bevel of the blade. The diameter of the blade is in this way gradually reduced from the original dimension to a minimum dimension of diameter, beyond which the blade must be replaced. The cutting edge becomes blunted and damaged rather quickly and must be sharpened frequently, which causes relatively rapid consumption of the blade, due to the wear caused by each sharpening operation. This makes it necessary to use high initial diameters, in order to reduce the number of replacements required and above all to amortize the cost of each blade against a sufficient quantity of cut product.

The dimension of the product to be cut and of the hub to support the disk-shaped cutting blade make it impossible to go below a minimum dimension of diameter.

The biconical shape of the tool produces a great deal of friction between the tool and the material to be cut. Moreover, to produce a biconically shaped tool, a large amount of initial raw material is required, as the biconical shape is obtained principally through grinding.

To decrease these drawbacks blades have been designed with a cutting edge defined by two asymmetrical sides, one of which is hardened by facing the cutting profile with hard oxides. A blade of this type is described in WO-A-0021722. The purpose of this known blade is to increase the quantity of logs cut during the life of the blade, to reduce the number of sharpenings required during the useful life of the blade and to reduce the variation in blade diameter due to wear caused by sharpening. However, this blade did not attain the expected results in terms of duration, decrease in wear and reduction of sharpening frequency.

Objects and summary of the invention

The object of the present invention is to provide a circular blade with a continuous cutting edge, which overcomes the drawbacks of prior art blades. A further object of the present invention is to produce a sharpening unit that makes it possible to sharpen the blade efficiently decreasing wear and avoiding the need for substantial excursions of the sharpening grinding wheels to compensate for wear of the blade resulting from frequent sharpening operations.

Yet another object of the present invention is to produce a method of sharpening that is simpler and more efficient sharpening than prior art methods, and a cutting

machine that implements said method.

Essentially, according to a first aspect, the present invention relates to a disk-shaped blade to cut logs of wound web materials, comprising an axis of rotation and a cutting bevel, with a continuous cutting edge, defined by a first side and by a second side, the first side having a greater radial extension, and at least said first side having surface hardening treatment. Characteristically, according to the invention, the surface treatment has a penetration depth or a thickness of at least 30 micrometers and preferably more or less equal to or greater than 80 micrometers and even more preferably equal to or greater than 90 micrometers and even more preferably equal to around 100 micrometers or more.

In the context of the present description and of the attached claims, by surface treatment it is understood either a treatment which provides for the penetration of atoms or molecules of a material inside the base structure of the blade (such as a nitriding or carburizing, for example), or also a deposit – on the base material forming the blade – of a layer of harder material, such as a layer of carbides, a layer of ceramic material or of other hardening material, having a suitable thickness.

The penetration depth of the treatment or, generally speaking, the treatment thickness, is such as to ensure that the bevel formed by sharpening has a portion integrally formed in the thickness of the surface hardening, being it provided by penetration or by deposit.

Advantageously and preferably, at least the first side of the bevel has a surface hardness equal to or greater than 70 HRC (Rockwell Hardness C) and preferably equal to or greater than around 72 HRC and even up to 73 HRC.

Advantageously, the blade is produced in alloy steel, such as molybdenum chrome steel, and at least the surface of the first side is treated by controlled nitriding, such as by Nitreg[®] surface treatment.

Nitreg[®] treatment is a special thermochemical nitriding treatment for hardening the surface of steels. For a description of the process see A.M. Staines, <<NITREG-A New Development in Gaseous Nitriding>>, published by Nitriding Services Ltd, Telford, Shropshire, UK. Nitriding treatments of this type are described in US-A-4391654, US-A-5,228,929, US-2002/0104587A1, EP-A-1229143. The treatment in question makes it possible to attain high degrees of hardness maintaining a high level of toughness in the material treated.

When the blade is new, that is before being sharpened for the first time, the

two sides defining the cutting bevel may have symmetrical inclinations, that is they may define the same angle in respect of the lying plane of the cutting edge. However, it is preferable for the first side to have a lesser inclination than the second side in respect of the lying plane of the cutting edge. This makes it possible, as shall become
5 clear hereunder, to position the sharpening grinding wheels in symmetrical positions and to produce, during the life of the blade, a cutting edge symmetrical in respect of the lying plane. For example, the difference in inclination between the first and the second side is at least 1° and preferably between around 1.5° and around 2.5° and even more preferably around 2° . According to an advantageous embodiment, the first
10 side can have a zero inclination with respect to the median plane of the blade, i.e. with respect to the lying plane of the cutting edge of the blade.

When the blade is new, that is before wear determined by successive sharpenings, the cutting edge may lie on a lying plane that does not coincide with the plane of the center line of the blade and, in respect of this, is moved towards the second
15 side.

The disk-shaped blade may be biconical in shape, that is with a body delimited by two opposed conical surfaces, with a wide aperture. Nonetheless, according to a preferred embodiment of the invention, the body of the blade is delimited by two planes essentially parallel to each other and essentially orthogonal to the axis of rotation of the blade.
20

According to a different aspect, the present invention relates to a sharpening unit to sharpen a disk-shaped blade, with a cutting bevel with a continuous circular cutting edge, and comprising a first grinding wheel and a second grinding wheel acting on a first side and on a second side of said bevel. Characteristically, according to
25 the invention, the first grinding wheel has a finer grain than the second grinding wheel. Moreover, the inclination of the first grinding wheel is not parallel to the respective first side of the bevel of the blade, while the inclination of the second grinding wheel is essentially parallel to the second side of said bevel.

The two grinding wheels are advantageously equipped with a movement to
30 move them towards and away from the blade in a direction essentially parallel to their respective rotation axis. The object of this movement is to position the grinding wheels in the operating and non-operating position respectively and also to recover wear of the blade caused by the successive sharpening operations.

The grinding wheel with larger grain is used to perform the actual sharpening

and acts on the side of the bevel that, following initial sharpening, loses the surface hardening treatment. On the contrary, the first grinding wheel, with extremely fine grain, acts on the side of the bevel destined to preserve the surface hardening treatment and acts simply to remove any burrs from the cutting edge, while also supporting the blade to prevent flexure caused by the pressure exerted by the second grinding wheel. The two grinding wheels may start to operate simultaneously. Nonetheless, to obtain optimal operation of the sharpening unit, the finest grinding wheel starts to operate before the grinding wheel with the larger grain and leaves the operating position with a delay. Preferably, the delay with which the first grinding wheel disengages from the blade in respect of the moment at which the second grinding wheel ceases to act on the bevel of the blade is equal to at least one complete turn of the blade. This ensures that any burrs are eliminated from the cutting edge.

The inclination of the first grinding wheel allows it to operate only in proximity to the cutting edge, that is at the tip of the bevel, and not along the entire extension of the side of the bevel. The thickness of surface treatment on the blade, the fact that the grinding wheel is not aggressive and its angular position in respect of the side of the bevel mean that the cutting edge, that is the line of intersection of the two sides and the surface area of the blade immediately adjacent to this line remain within the thickness of the material of the blade that has been subjected to the surface hardening treatment. Independently of whether it is formed by a deposit or by the penetration of particles – e.g. by thermal treatment – in the structure of the base material forming the blade.

The grinding wheels may be idle and hence drawn in rotation by the rotating blade. Nonetheless, they are preferably motorized. The motorized grinding wheels may be pressed against the blade with less pressure, thus making it possible to obtain a smoother ground surface. Mixed solutions may also be used in which one grinding wheel is drawn and the other motorized or in which there are more than two grinding wheels, some motorized and others drawn.

Preferably, according to a particularly advantageous embodiment of the invention, the inclinations of the two grinding wheels are equal and opposite in respect of the lying plane of the cutting edge of the blade.

According to another aspect, the present invention relates to a cutting machine to cut logs of wound web material, comprising: a feed path of the logs to be cut; at least a disk-shaped blade rotating about an axis of rotation and having a cut-

ting bevel, with a continuous cutting edge, said bevel being defined by a first side and by a second side, the first side having a greater radial extension in respect of the second side, and at least said first side having a surface hardening treatment; a sharpening unit for the blade, with at least a first grinding wheel acting on the first side
5 and a second grinding wheel acting on the second side. Characteristically, according to the invention, the first grinding wheel has a finer grain than the second grinding wheel; and the inclination of the first grinding wheel is greater than the inclination of the first side of the bevel in respect of a lying plane of the cutting edge of the blade, while the inclination of the second grinding wheel is essentially parallel to the second
10 side of said bevel. In this way the first grinding wheel acts only on the terminal part of the bevel, that is the part nearest to the cutting edge, while the second blade acts on the entire radial extension of the bevel.

Advantageously, the inclination of the first grinding wheel in respect of the first side of the bevel and the thickness of the hardening treatment may allow the cutting edge of the blade to remain within the volume that has been subjected to the
15 hardening treatment.

Yet another aspect of the present invention relates to a method to sharpen a disk-shaped blade rotating about an axis of rotation, said blade having a cutting bevel, with a continuous cutting edge, said bevel being defined by a first side and by
20 a second side, the first side having a greater radial extension than the second side, and at least said first side having a surface hardening treatment. According to the method a first grinding wheel acts on the first side and a second grinding wheel acts on the second side. Characteristically, according to the invention: the first grinding wheel has a finer grain than the second grinding wheel; the first grinding wheel is
25 moved against the first side of the blade with an inclination slightly greater than the inclination of the first side, in respect of a laying plane of the cutting edge of the blade; and the second grinding wheel is moved against the second side of the bevel with inclination essentially corresponding to the inclination of said second side in respect of said laying plane.

30 Further advantageous characteristics and embodiments of the blade, the sharpening unit, the cutting machine and the sharpening method according to the invention are indicated in the appended dependent claims.

Brief description of the drawings

The invention shall now be better understood by following the description

and appended drawing, which shows a non-limiting practical example of the invention. In the drawing:

Figure 1 shows a summary side view of a cutting machine according to the invention;

5 Figure 2 shows a front view according to II-II in Figure 1;

Figure 2A shows a development in the plane of the control cam in Figure 2;

Figure 3 shows a side view and part section according to III-III in Figure 2;

Figure 4 shows a partly enlarged section of a detail of Figure 3;

Figure 5 shows a front view of a cutting blade;

10 Figures 6A and 6B shows two enlarged local sections according to a radial plane of the cutting bevel of the blade in Figure 5, respectively of the new blade and of the completely worn blade;

Figure 7 shows a greatly enlarged view of the cutting bevel and of the cutting edge of the blade during use and after at least a first sharpening;

15 Figure 8 shows an enlarged view of the arrangement of the sharpening grinding wheels of one of the sharpening units of the cutting machine;

Figure 9 shows a longitudinal section of one of the two grinding wheels with the respective operating mechanism; and

Figure 10 shows a part cross-section according to X-X in Figure 9.

20 Detailed description of the preferred embodiment of the invention

Figure 1 schematically shows (limited to its front part) a cutting machine, as a whole indicated with 1, to which the present invention is applied. The machine has a feed path of the logs to be cut, indicated with L, which are pushed by pushers 3 secured to a flexible chain element or the like 5, driven about a driving wheel supported by a fixed structure 7. Only one driving wheel, indicated with 9, is visible in Figure 1, while the other is at the rear end of the cutting machine, not shown. In actual fact, as known to those skilled in the art, there are more than one flexible elements 5 in parallel to feed several rows of logs L according to parallel paths. In the example shown four channels are provided for simultaneous feed of four logs L positioned side by side.

The flexible elements 5 associated with the various parallel feed channels of the logs may be motorized separately from one another to stagger the movement of logs in each feed channel.

The number 11 generically indicates a cutting head that, by means of a sup-

port 13, carries a rotating unit 17. The unit 17 rotates about a horizontal axis A-A parallel to the direction fL of feed of the logs L. In the example shown, three disk-shaped blades 19A, 19B and 19C are mounted on the rotating unit 17, disposed at 120° from one another about the axis A-A, as can be seen in particular in Figure 2.

5 Each of the rotating disk-shaped blades 19A, 19B and 19C rotates about its own axis of rotation B-B parallel to the axis A-A and to the direction of feed fL of the logs L.

The number 21 indicates a motor that, by means of a belt 23, transmits rotatory motion to the rotating unit 17. A second motor 25 is positioned on the support 13 of the rotating unit 17 and, by means of a belt 27, supplies rotatory motion to a shaft that drives disk-shaped blades 19A, 19B and 19C in rotation by means of a transmission to be described hereunder. By means of a belt 31, a third motor 29 drives the driving wheel 9 of the rotating element 5 in rotation. As mentioned above, as several parallel channels may be provided for feeding the logs L that are cut separately to form the small rolls R, a driving wheel 9 may be associated with each channel, with its own motor unit 29 suitably controlled as a function of the angular position of the rotating unit 17. The number 35 indicates a programmable control unit that synchronizes the angular position of the unit 17 with the feed movement of the flexible element(s) 5 acting on the motor(s) 29.

10
15

Figures 2 and 3 show how the rotating unit 17, drawn in rotation by the hub 17A, internally supports three toothed wheels, positioned at 120° from one another about the axis A-A, indicated with 41A, 41B and 41C. Said wheels mesh with a central toothed wheel 43 keyed onto a shaft 45 that receives its motion from the motor 25 through the belt 27.

20

The toothed wheels 41A, 41B and 41C are keyed onto respective spindles 47A, 47B and 47C onto which toothed pulleys 49A, 49B and 49C are in turn keyed. Each of the toothed pulleys 49A, 49B, 49C transmits the motion supplied by the motor 25, through toothed belts 51A, 51B, 51C, to the rotating disk-shaped cutting blades 19A, 19B e 19C.

25

As can be seen in the detail in Figure 4 for the blade 19C, the toothed belt 51A, 51B, 51C transmits motion to a toothed pulley 53A, 53B, 53C keyed onto an axle 55A, 55B, 55C, on the opposite end of which the respective disk-shaped blade 19A, 19B, 19C is keyed.

30

Each of the shafts is supported by bearings 57 in a respective sleeve 59A, 59B, 59C sliding on sliding bearings 61 mounted in a respective seat 63A, 63B, 63C

provided in the rotating unit 17. The angular movement about the axis B-B of each sleeve 59A, 59B, 59C is prevented by a tab 58 integral with the respective sleeve, cooperating with wheels 60 supported idle in the sliding seat of the sleeve.

At the rear, that is on the opposite side in respect of the disk-shaped blade 19C, each sleeve 59A, 59B, 59C has an enlarged area 65A, 65B, 65C that houses the toothed pulley 53A, 53B, 53C respectively, and mounted idle on which is a wheel 67A, 67B, 67C that constitutes the feeler for a fixed cam 71 extending in an arc of circumference, shown in particular in Figure 2 and in its development in the plane in Figure 2A.

The arc of circumference along which the cam 71 extends has its center on the axis A-A of rotation of the rotating unit 17 and extends in the lower part of the path of each disk-shaped blade 19A, 19B, 19C, i.e. in the zone in which the blade is inserted into the product to be cut.

Through the effect of the cam 71 and of the feeler 67A, 67B, 67C each sleeve 59A, 59B, 59C associated with the respective disk-shaped blade 19A, 19B, 19C travels with alternate motion according to the double arrow f1. Consequently, the respective disk-shaped blade 19A, 19B, 19C are provided with the same motion. The movement according to the arrow f1 is parallel to the direction of feed of the logs L or other elongated products to be cut. Contact of the feeler 67A, 67B, 67C with the annular cam 71 is ensured by an arrangement of Belleville springs 72A, 72B, 72C that act between the rotating unit 17 and the enlarged portion 65A, 65B, 65C of the sleeve 59A, 59B, 59C.

Along the lower arc of the circular trajectory taken by each disk-shaped blade 19A, 19B, 19C, the blade is pushed forwards by the annular cam 71 that overcomes the compression strength of the respective Belleville springs 72A, 72B, 72C. In this way the blade that is operating at that time, i.e. inserted in the material constituting the log(s) L to be cut, moves forward following the forward motion of the logs L along the feed path.

The forward movement is controlled by the ascending ramp 71A of the cam 71 (see Figure 2A). The forward motion starts before the respective blade 19A, 19B, 19C penetrates the material constituting the first of the logs to be cut, so that at the time in which contact with the blade starts it is already moving forward at the same speed as the material to be cut according to the arrow fL.

When the blade emerges from the log(s) L, it is made to reverse by the

springs 72 that maintain the feeler 67 in contact with the descending ramp 71D of the circular cam 71, which may be limited to a portion of the circumference followed by the feeler 67C, as in the upper stretch of travel the blade 19A, 19B or 19C does not require to follow the movement of the roll. Forward motion of the logs L is controlled in the same way described in EP-B-0507750.

The considerable length of the belts 51A, 51B and 51C provides the toothed pulley 53A, 53B or 53C with sufficient freedom of movement in the axial direction, so that the respective disk-shaped blades may advance and reverse without being obstructed by mechanical transmission of motion from the central axis. The axial extension of the toothed pulleys 53A, 53B, 53C and 49A, 49B, 49C may be greater than the height of the respective belts 51A, 51B, 51C to allow any minor sliding of the belts on the driving pulleys.

Integral with each sleeve 59A, 59B, 59C is a support 73A, 73B, 73C, each carrying a sharpening unit 80 comprising a pair of grinding wheels 81, 83 to sharpen the respective rotating disk-shaped blades 19A, 19B, 19C. Each grinding wheel of the pair of grinding wheels 81, 83 associated with each blade acts on one of the two sides of the cutting bevel of the blade, which will be described in detail with reference to Figures 5 to 7.

The grinding wheels 81 and 83 may be motorized grinding wheels, that is drawn in rotation by specific motors such as pneumatic motors, although it is also possible to use grinding wheels mounted idle and drawn in rotation through the effect of contact friction with the disk-shaped blade. Feed of compressed air to the actuators associated with the three pairs of grinding wheels 81, 83 may be supplied by an axial rotating distributor, not shown and of a per se known type.

The two grinding wheels 81, 83 of each sharpening unit 80 are also provided with a movement parallel to their axis of rotation to be brought alternately into contact with and moved away from the respective rotating disk-shaped blade, as sharpening is not continuous but performed only at regular intervals as the blade becomes blunt and thus requires sharpened. The structure of the mechanisms that make the grinding wheels rotate and cause them to move towards and away from the respective blade will be described with reference to Figures 9 and 10. The arrangement of the two grinding wheels 81, 83 of each sharpening unit 80 is shown in particular in the enlarged detail in Figure 8.

Each of the blades 19A, 19B, 19C is designed as shown in Figures 5 to 7,

which show any one of the three blades 19A, 19B, 19C, indicated simply with the reference 19.

The blade 19 has a disk-shaped body delimited by two flat faces 201A, 201B parallel to each other, and a circular cutting edge 203. Therefore, essentially it has a
5 continuous thickness in the range of 1.5-4 mm and preferably between 2 and 3 mm, in particular for example 2.5 mm.

The cutting edge 203 represents the final edge of a cutting bevel, indicated as a whole with 205. This cutting bevel is delimited by two sides 207 and 209. The first side 207 extends radially (i.e. in the direction of the radius of the disk-shaped blade)
10 to a greater extent than the radial extension of the second side 209, in any condition of wear of the blade.

At least the side 207 has been subjected to surface hardening treatment. In a practical embodiment described here by way of example, said treatment is a controlled nitriding thermal treatment, such as in particular Nitreg® treatment. In actual
15 fact, the entire surface of the blade may be subjected to this treatment, as it is simpler and less expensive to perform complete treatment than to mask the parts of the blade that do not require to be treated. Alternatively, the entire surface of the blade may be subjected to treatment, with the exception of the side of the cutting bevel on which the grinding wheel with the largest grain, destined to perform actual sharpening, acts.
20 In this way the duration of the grinding wheel may be extended. The controlled thermochemical nitriding treatment penetrates the base material of the blade for a depth T (Figure 7), for example of around 100 micrometers. Alternatively, as set forth herein before, the surface hardening treatment can be provided in the form of a deposit of a harder material on the surface of the blade, or even in a depressed area of
25 the blade body provided for the purpose of being filled up with said deposit.

Figure 6A shows the bevel of the blade before the first sharpening operation with continuous surface treatment along its entire surface. In this initial condition, the cutting edge 203 lies on a lying plane PG parallel to the median plane PM of the blade, which is represented by the plane orthogonal to the axis B-B of rotation and
30 equidistant from the faces 201A, 201B of the body of the blade. The lying plane PG of the cutting edge 203 is shifted, in respect of the median plane PM of the blade, towards the second side 209 of the bevel 205.

Still in the condition of a new blade, represented in Figure 6A, the side 207 is defined by a conical surface with axis coinciding with the axis B-B of rotation of the

blade and with an inclination α in respect of the lying plane PG of the cutting edge 203. The angle α may for example be around 8° . The side 209 also has a conical form coaxial to the axis B-B and an inclination β in respect of the plane PG. The angle β is slightly greater than the angle α and may be for example equal to 10° . The possibility is not excluded, however, that the angle α is 0° .

In Figure 6B the blade is shown in its condition of maximum wear. The sides 207, 209 still have the same inclination, although the side 207 now extends in a radial direction for less than the side 209. Moreover, the lying plane PG of the cutting edge 203 is moved in respect of the median plane PM towards the first side 207 and not towards the second side 209. As the relative dimensions of the two sides vary as the blade becomes worn, unless otherwise specified in the present text and in the appended claims, reference is generally made to the dimensions of the new blade, that is before wear caused by initial sharpening.

The blade is produced in molybdenum chrome steel, such as X150CrMo12 steel, which with Nitreg[®] treatment even reaches a hardness equal to 72-73 HRC for the penetration depth of the controlled nitriding treatment.

As shown in particular in the enlarged detail in Figure 8, the two grinding wheels 81 and 83 are disposed with equal inclination and contrary in respect of the lying plane PG of the cutting edge 203 of the blade 19, that is in respect of a plane orthogonal to the axis B-B of rotation of the blade 19. More specifically, the two grinding wheels are inclined by an angle β in respect of the lying plane of the cutting edge of the blade. This means that the grinding wheel 83, which acts on the side 209 inclined by an angle β in respect of the plane PG, operates parallel to the side and performs the actual sharpening of the blade. Removal of material from the side of the blade by the second grinding wheel 83 does not alter the conical shape of the side 209 of the bevel and its inclination in respect of the original inclination.

On the contrary, the first grinding wheel 81, which acts on the side 207 of the bevel 205, only touches the side in the area nearest the cutting edge, due to the difference in inclination between the side 207 (inclined by an angle α in respect of the plane PG) and the grinding wheel (inclined by an angle β in respect of this plane). The contact conditions between the sides of the bevel 205 and the two grinding wheels are shown in the enlargement in Figure 7, where the two grinding wheels 81, 83 are indicated with a dashed line. As can be seen in Figure 7, due to the slight dif-

ference between the inclination of the side 207 and of the grinding wheel 81, and due to the considerable depth T of the surface hardening treatment, the cutting edge 203 is produced wholly in a thickness of the material of the blade 19 subjected to this treatment. The cutting edge 203 and the portions of the sides of the bevel immediately adjacent to this cutting edge always remain within the thickness that has been subjected to hardening notwithstanding the amount of wear on the blade. Therefore, the cutting edge is hardened on both sides. Moreover, thanks to the symmetrical layout of the grinding wheels 81, 83, it has a symmetrical section in respect of its lying plane PG, with consequent advantages in terms of dynamic stresses on the blade.

10 The two grinding wheels 81 and 83 have markedly distinct abrasive characteristics. In fact, as mentioned hereinbefore, the second grinding wheel 83 is utilized for the actual sharpening operation and consequently has a grain size suitable for this purpose. On the contrary, the function of the grinding wheel 81 is to support the blade against the stresses exerted by the grinding wheel 83 and to eliminate any burrs produced along the cutting edge 203 by said grinding wheel 83, although it does not actually perform any sharpening operations, but merely polishes the bevel. Therefore, it will have a much finer grain size than the grinding wheel 83 and will not abrade the surface layer of the side 207 that has been subjected to the hardening treatment, except to a negligible extent and only in proximity of the cutting edge, that is at the tip of the bevel 205.

Typically, with reference to DIN standards and ISO 6106-1979 standards, the grinding wheel 81 may have diamond grains or equivalent and have an <<extremely fine>> grain, that is from 7 to 46 (ISO standards), and preferably in proximity or equal to the minimum value 7, corresponding to a dimension of the sieve from 37 to 44 micrometers. The grinding wheel 83 may, on the contrary, be produced with the same type of abrasive and <<fine>> grain according to DIN and ISO 6106-1979 classification, that is between 45 and 91 (ISO standards), corresponding to screen meshes with dimensions between 53 and 74 micrometers. Preferably the grain size of this grinding wheel is around 70-80 (ISO).

30 With this arrangement wear of the blade caused by sharpening is very limited and a considerably long useful life of the blade is obtained, greater than the useful life of traditional grinding wheels (in terms of number of cuts made), with a limited variation in the total diameter of the blade, for example of about 15-20 mm for blades with initial diameters usually between around 500 and 600 mm.

In addition to a lower cost for expendable materials, this also has the advantage of eliminating the need to provide the grinding wheels with a movement to move them gradually towards the axis of the blades in order to recover wear, and to adjust the position of the blade in respect of the axis of rotation of the unit carrying it, as the variation in diameter resulting from wear can be recovered by the simple movement towards the blade and away there from, with which the grinding wheels are periodically brought in the operating and non-operating position respectively.

Figure 9 shows a longitudinal section of one of the grinding wheels 81 and of the relative axial supporting and traversing and rotation system. The grinding wheel 83 is mounted and rotation and traverse movement are controlled in the same manner.

The grinding wheel 81 is keyed onto a shaft 85 supported by bearings 87 in a bushing 89. The bushing slides on the sliding bearings 91 inside a supporting sleeve 93 connected integral with the support 73C. At the opposite end in relation to the position of the grinding wheel 81 the shaft 85 is connected to a hollow shaft 95 coupled by a spline coupling 97 to the motor shaft 99 of a pneumatic or equivalent motor 101.

The bushing 89 has a helical groove 103 that extends through an arc of helix extremely reduced and inclined greatly in respect of the axis C-C of the shaft 85 of the grinding wheel 81. A wheel 105 mounted idle on a spindle 106 supported by the support 93 engages in the helical groove 103. The arrangement of the groove 103 and of the wheel 105 may be inverted, with the groove integral with the supporting sleeve 93 and the wheel integral with the bushing 89.

With this arrangement angular oscillation about the axis C-C of the bushing 89 causes it to slide axially along the axis C-C through the effect of the wheel 105 that acts as a tappet inside the helical channel 103 that acts as a desmodromic cam.

Angular movement about the axis C-C of the bushing 89 is imparted by a pair of piston-cylinder actuators 108A, 108B parallel to each other, visible in particular in the section in Figure 10. The cylinders of these actuators are integral with the supporting sleeve 93, while the rods extend inside the sleeve and their ends rest on a leveled surface 110 produced on the bushing 89. By extending one of the two actuators 108A, 108B and retracting the other this causes oscillation of the bushing 89 about the axis C-C and consequently axial movement of the bushing and of the grinding wheel supported by it.

With an arrangement of this type it is possible to control, with great precision,

the pressure that each of the two grinding wheels 81, 83 exerts on the respective side of the corresponding disk-shaped blade 19A, 19B, 19C. This is obtained by controlling the pressurized fluid inside the actuators 108A, 108B. In this way sharpening of the blades can be controlled accurately, limiting wear and at the same time maintaining optimal sharpening.

It is understood that the drawing merely shows a non-limiting example of the invention, which may vary in shapes and arrangements without however departing from the scope of the concept on which the invention is based. Any reference numbers in the appended claims are provided to facilitate their reading with reference to the description hereinbefore and the appended drawings, and do not limit the scope of protection.

Claims

1. A sharpening unit to sharpen a disk-shaped cutting blade with a bevel with a continuous circular cutting edge, comprising a first grinding wheel and a second grinding wheel acting on a first side and on a second side of said bevel, wherein said first grinding wheel has a finer grain than said second grinding wheel; the inclination of said first grinding wheel is such that when the unit is in operation, said first grinding wheel is placed against the first side of the blade with a slightly greater inclination than the inclination of the first side, in respect of a lying plane (PG) of the cutting edge of the blade, while the inclination of said second grinding wheel is substantially parallel to the second side of said bevel, and said second grinding wheel is arranged and designed to sharpen the cutting bevel of the blade, while said first grinding wheel is arranged and designed to apply a reaction force to said blade to prevent or reduce flexure of the blade in the sharpening area and eliminating any burrs produced by the second grinding wheel from the cutting edge.

2. Sharpening unit as claimed in claim 1, wherein said first and said second grinding wheel are provided with a movement to move towards and away from the blade according to a direction essentially parallel to their axes of rotation.

3. Sharpening unit as claimed in claim 2, wherein the movement to move said first and said second grinding wheel towards the blade is controlled so that the first grinding wheel comes into contact with the first side of the blade before the second grinding wheel comes into contact with the second side of the blade, and moves out of contact with said first side of the blade after the second grinding wheel has moved out of contact with the second side of the blade.

4. Sharpening unit as claimed in claim 3, wherein the movement to move the grinding wheels towards and away from the blade is controlled so that the first grinding wheel moves out of contact with the first side of the blade after said blade has made at least one turn around its axis subsequent to the second grinding wheel moving away from the second side.

5. Sharpening unit as claimed in any one of claims 1 to 4, wherein said first and said second grinding wheel are motorized.

6. Sharpening unit as claimed in any one of claims 1 to 5, wherein the inclinations of said first and said second grinding wheel are equal and opposite in respect of a lying plane of the cutting edge of the blade, said lying plain being essentially orthogonal to the axis of rotation of the blade.

5 7. Sharpening unit as claimed in any one of claims 1 to 6, wherein said first grinding wheel has an extremely fine grain, from 7 to 46 according to ISO standards, and preferably around 7.

8. Sharpening unit as claimed in any one of claims 1 to 7, wherein said second grinding wheel has a fine grain, between 45 and 91 according to ISO standards and preferably
10 between 70 and 80.

9. A cutting machine to cut rolls of wound web material, comprising:

- at least a disk-shaped blade rotating around an axis of rotation (B-B) and having a cutting bevel, with a continuous cutting edge, defined by a first side and by a second side, the first side having a greater radial extension than the second side, and at least said
15 first side having a surface hardening treatment;
- at least a sharpening unit for said blade, with at least a first grinding wheel acting on said first side and a second grinding wheel acting on the second side;

wherein said sharpening unit is produced according to any one of claims 1 to 8.

10. Cutting machine as claimed in claim 9, wherein the inclination of the first
20 grinding wheel in respect of the first side of the bevel and the thickness (T) of said hardening treatment allow the cutting edge of the blade to remain within the thickness that has been subjected to hardening treatment.

11. Cutting machine as claimed in claim 9 or 10, wherein said first and said second grinding wheel are equipped with a movement to move them towards and away from
25 the blade according to a direction essentially parallel to their respective axis of rotation, said movement also recovering wear on the blade caused by successive sharpenings.

12. Cutting machine as claimed in any one of claims 9 to 11, wherein the inclinations of said first and said second grinding wheel are equal and opposed in respect of a lying plane (PG) of the cutting edge of the blade, said plane being essentially orthogonal to the axis
30 of rotation (B-B) of the blade, and in that the inclinations of said two sides of the bevel of the

blade are different in respect of the lying plane (PG) of the cutting edge of the blade, the first side having, in respect of said lying plane, a lesser inclination than the second side.

13. Cutting machine as claimed in any one of claims 9 to 12, wherein said first side is substantially parallel to the lying plane (PG) of the cutting edge of the blade.

5 14. Cutting machine as claimed in claim 12, wherein the difference in inclination between said first and said second side is at least 1° and preferably between around 1.5° and around 2.5° .

15. Cutting machine as claimed in any one of claims 10 to 14, wherein the thickness of said hardening treatment of said first side is equal to or greater than 30 micrometers and preferably equal to or greater than 80 micrometers and even more preferably equal to or greater than 90 micrometers, and even more preferably equal to or greater than 100 micrometers.

16. Cutting machine as claimed in any one of claims 9 to 15, wherein at least said first side of the blade has a surface hardness greater than 70 HRC and preferably equal to or greater than around 72 HRC.

17. Cutting machine as claimed in any one of claims 9 to 15, wherein said blade is made of alloy steel.

18. Cutting machine as claimed in any one of claims 9 to 17, wherein at least said first side has a surface treatment obtained by penetration of molecules or atoms within the structure of the base material forming the blade.

19. Cutting machine as claimed in claim 18, wherein said surface treatment is a controlled nitriding treatment.

20. Cutting machine as claimed in any one of claims 9 to 17, wherein at least said first side has a surface treatment consisting in a deposit of a material which is harder than the base material forming the blade.

21. Cutting machine as claimed in claim 17, wherein said blade is made of chrome steel containing molybdenum.

22. Cutting machine as claimed in any one of claims 9 to 21, wherein the inclination of said first side is equal to or less than 9° and preferably equal to around 8° in respect of said lying plane (PG).

23. Cutting machine as claimed in any one of claims 9 to 22, wherein said blade has a body delimited by two planes essentially parallel to each other and essentially orthogonal to the axis of rotation (B-B) of the blade.

24. Method for sharpening a disk-shaped blade, to cut rolls of web material, rotating around an axis of rotation (B-B), said blade having a cutting bevel, with a continuous cutting edge, defined by a first side and by a second side, the first side having a greater extension in a radial direction than the second side, and at least said first side having a surface hardening treatment; wherein a first grinding wheel acts on said first side and a second grinding wheel acts on said second side,

10 wherein:

- said first grinding wheel has a finer grain than said second grinding wheel;
- said first grinding wheel is placed against the first side of the blade with a slightly greater inclination than the inclination of the first side, in respect of a lying plane (PG) of the cutting edge of the blade;
- 15 - said second grinding wheel is placed against the second side of the blade with an inclination essentially corresponding to the inclination of said second side in respect of said lying plane;
- wherein said second grinding wheel sharpens the cutting bevel, while said first grinding wheel applies a reaction force to said blade to prevent or reduce flexure of the blade in
20 the sharpening area and eliminates any burrs produced by the second grinding wheel from the cutting edge.

25 25. Method as claimed in claim 24, wherein by using a blade whose surface hardening treatment has a thickness of at least 30 micrometers and preferably equal to or greater than 80 micrometers and even more preferably equal to or greater than 90 micrometers and even more preferably equal to or greater than 100 micrometers.

26. Method as claimed in claim 24 or 25, wherein the inclination of the first grinding wheel in respect of the first side of the bevel and the thickness of said hardening treatment are such that the cutting edge of the blade remains within the thickness interested by the hardening treatment.

30 27. Method as claimed in any one of claims 24 to 26, wherein said first and said

second grinding wheel are motorized.

28. Method as claimed in any one of claims 24 to 27, wherein said first and said second grinding wheel are moved against said blade with a movement essentially parallel to the respective axis of rotation, said movement also recovering wear of the blade caused by successive sharpenings.

29. Method as claimed in claim 28, wherein the first grinding wheel comes into contact with the first side of the blade before the second grinding wheel comes into contact with the second side of the blade; and in that the first grinding wheel moves out of contact with said first side of the blade after the second grinding wheel has moved out of contact with the second side of the blade.

30. Method as claimed in claim 29, wherein the movement to move the grinding wheels towards and away from the blade is controlled so that the first grinding wheel moves out of contact with the first side of the blade after said blade has made at least one turn about its axis subsequent to the second grinding wheel moving away from the second side.

31. Method as claimed in any one of claims 24 to 30, wherein the inclinations of said first and said second grinding wheel are equal and opposed in respect of a lying plane of the cutting edge of the blade, essentially orthogonal to the axis of rotation (B-B) of the blade, and in that the inclinations of said two sides of the bevel of the blade in respect of the lying plane (PG) of the cutting edge of the blade are different, the first side being less inclined in respect of said lying plane than the second side, and in that said grinding wheels produce a symmetrical cutting edge in respect of the lying plane of the said cutting edge.

32. Method as claimed in claim 31, wherein the difference in inclination between said first and said second side is at least 1° and preferably between around 1.5° and around 2.5° .

33. Method as claimed in any one of claims 24 to 32, wherein it uses a first grinding wheel with an extremely fine grain, from 7 to 46 according to ISO standards, and preferably around 7.

34. Method as claimed in any one of claims 24 to 33, wherein it uses a second grinding wheel with a fine grain, from 45 to 91 according to ISO standards and preferably from 70 to 80.

1 / 10

Fig. 1

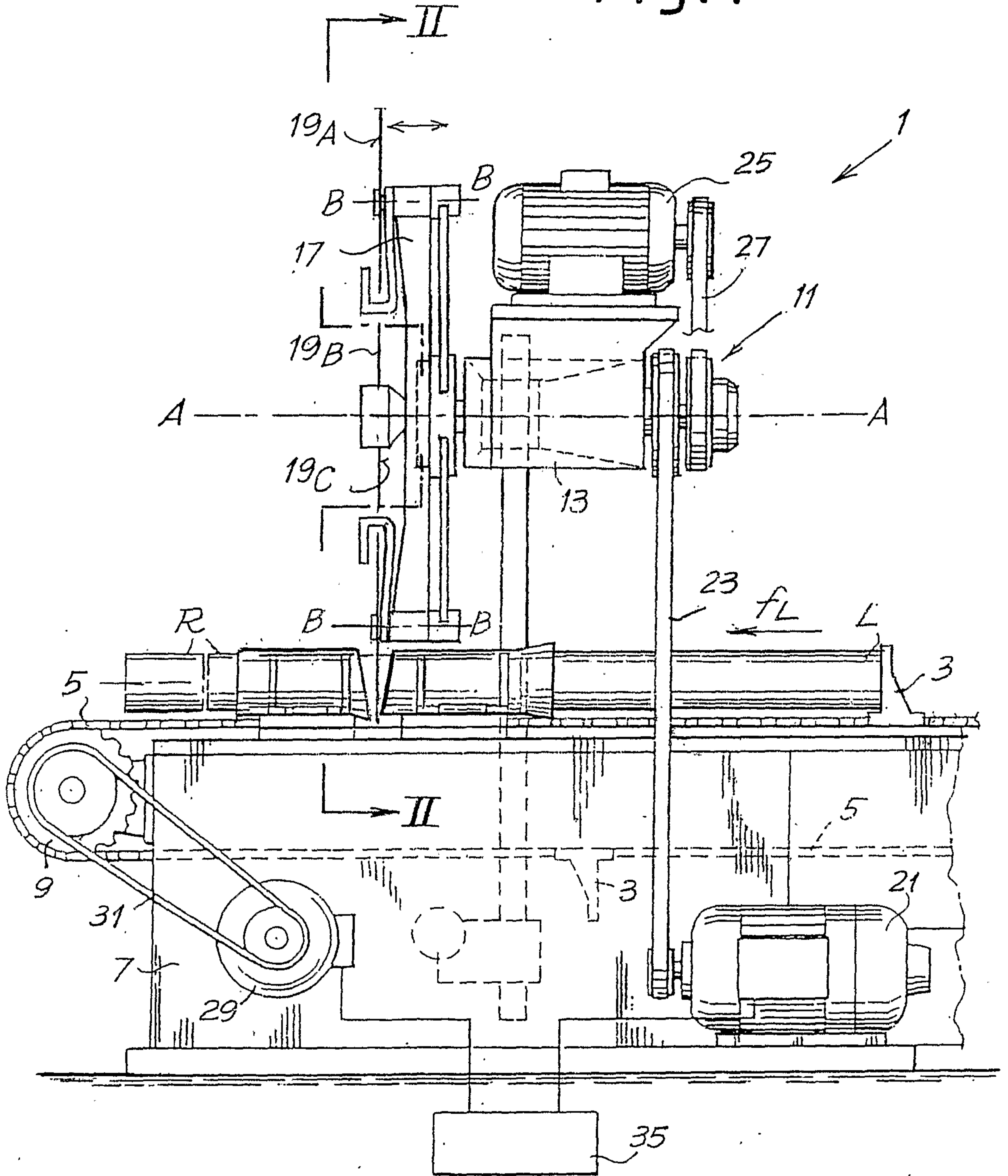

Fig. 2

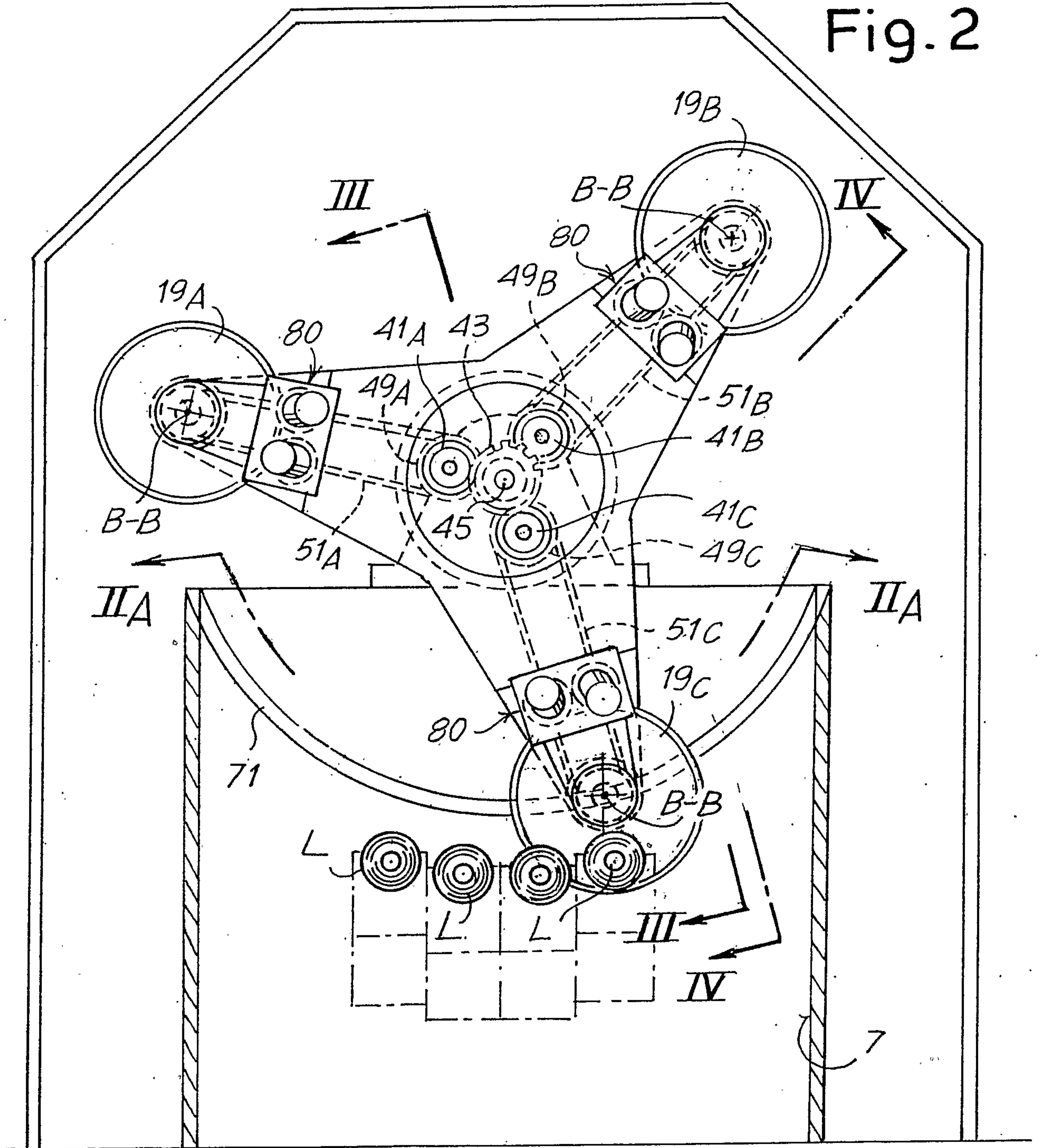
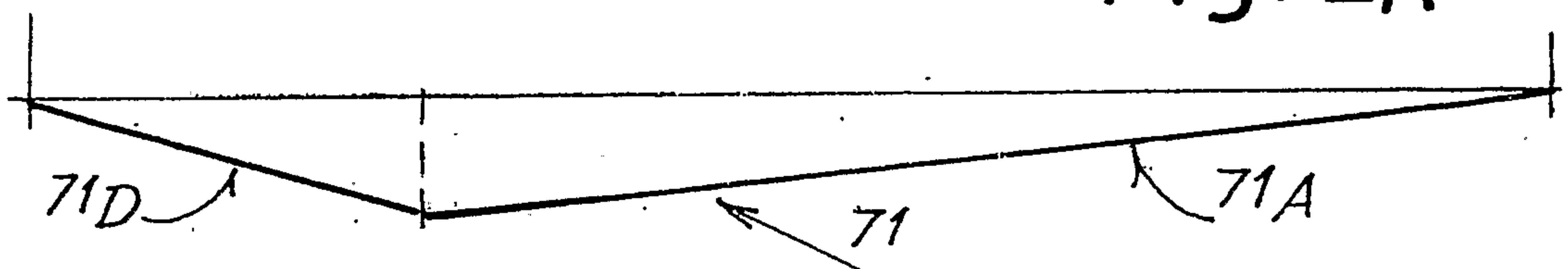
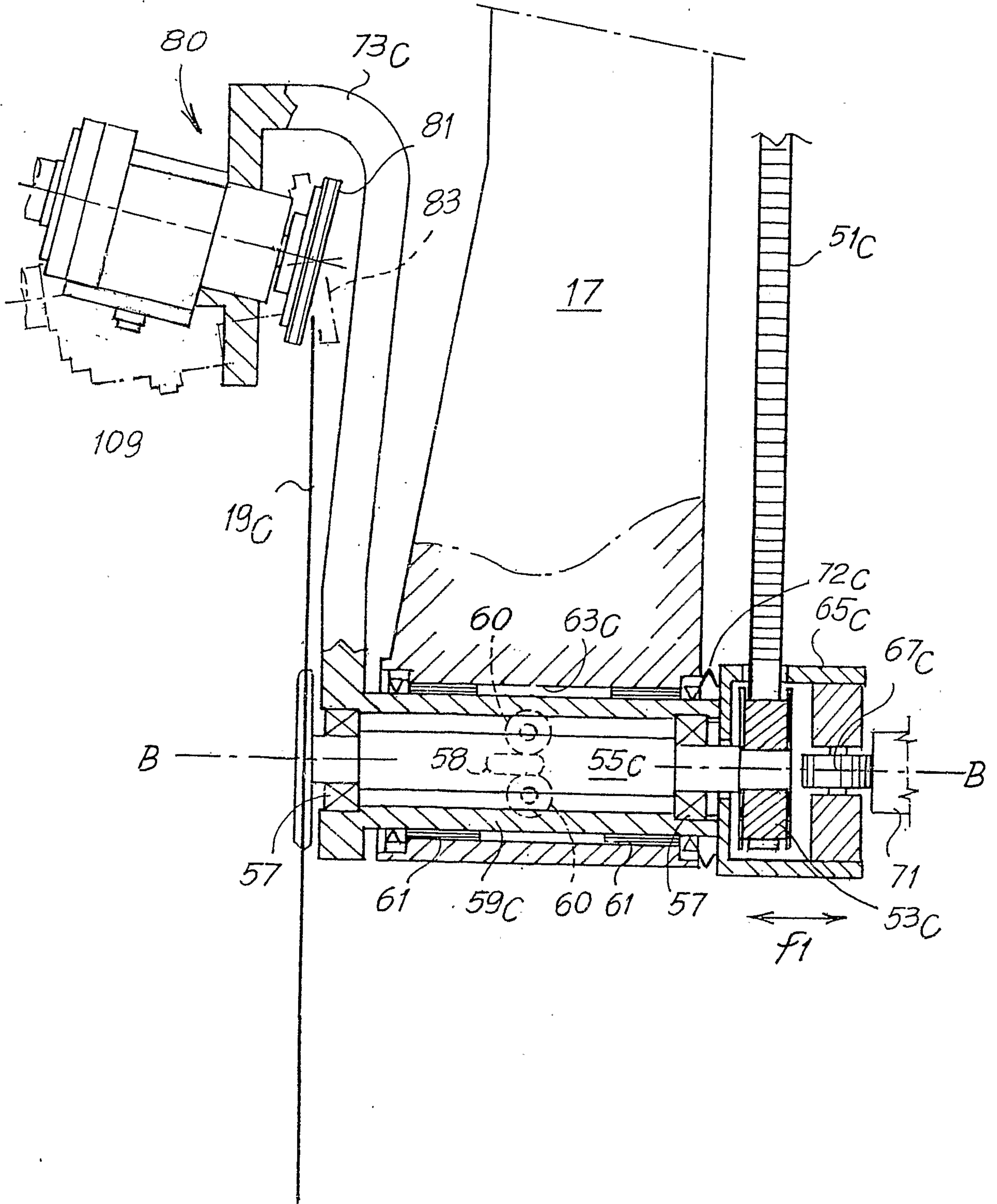

Fig. 2A



4 / 10

Fig. 4



5 / 10

Fig.5

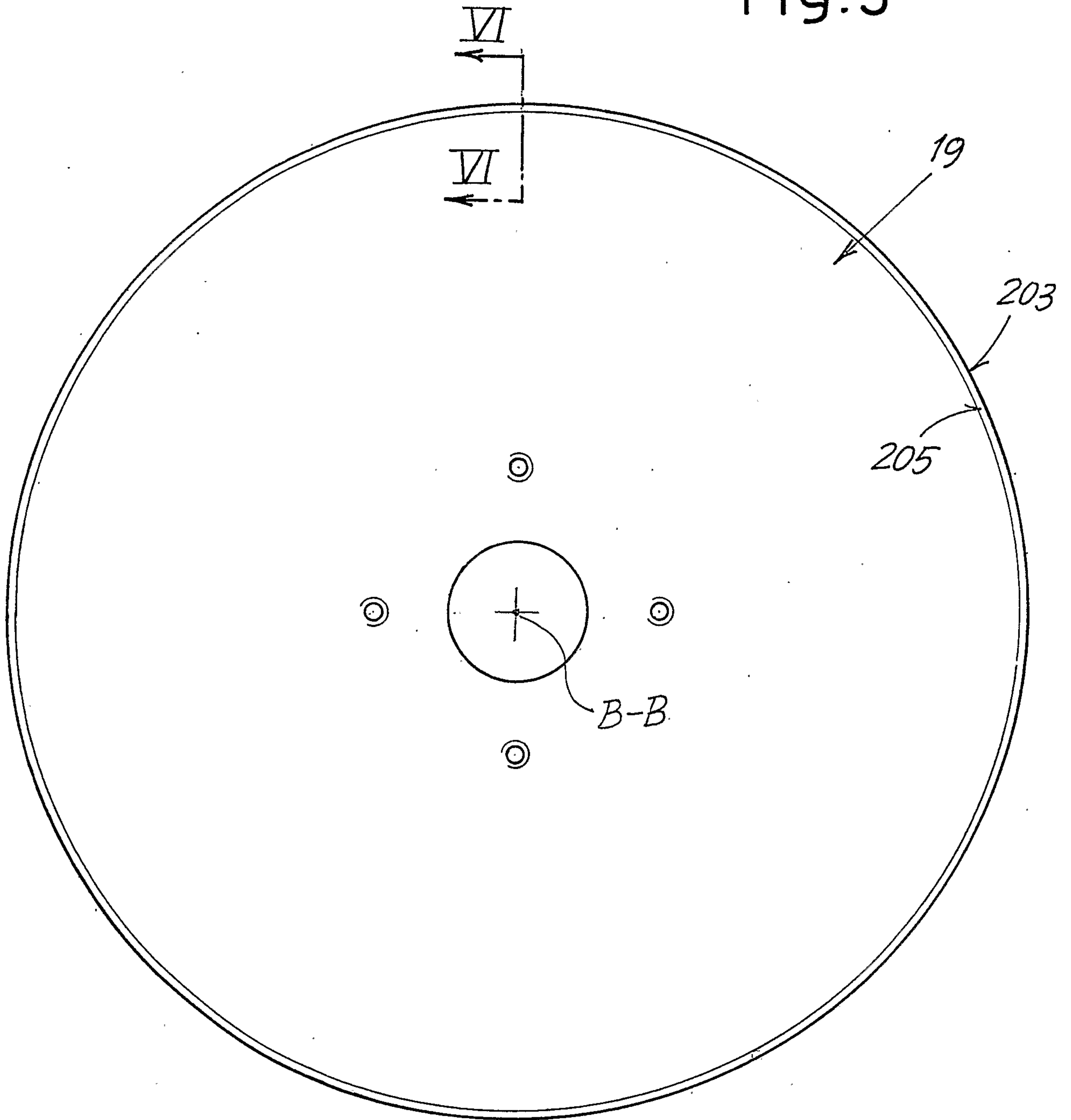

6 / 10

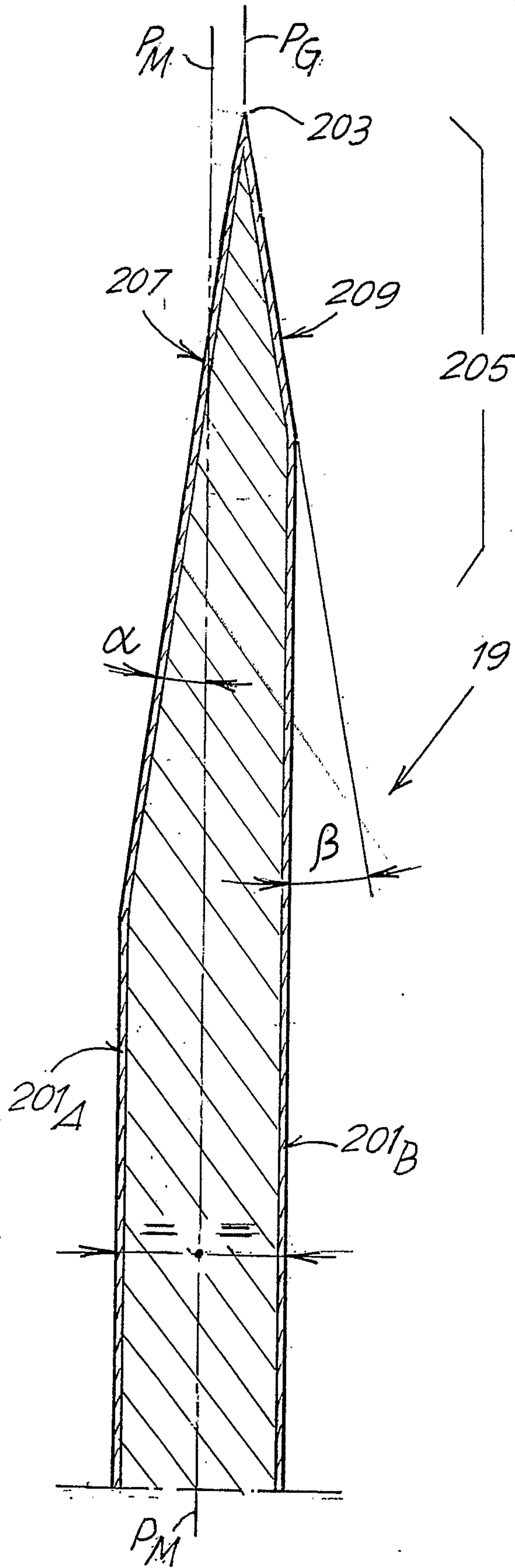

Fig. 6A

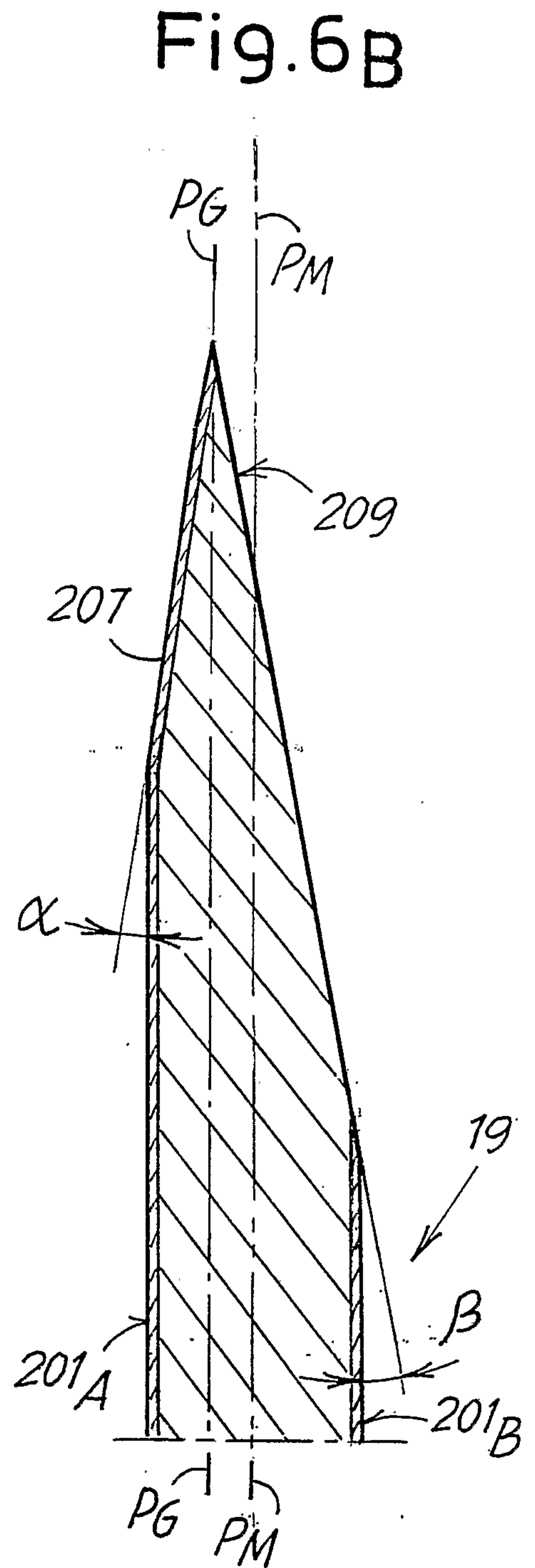

Fig. 6B

7 / 10

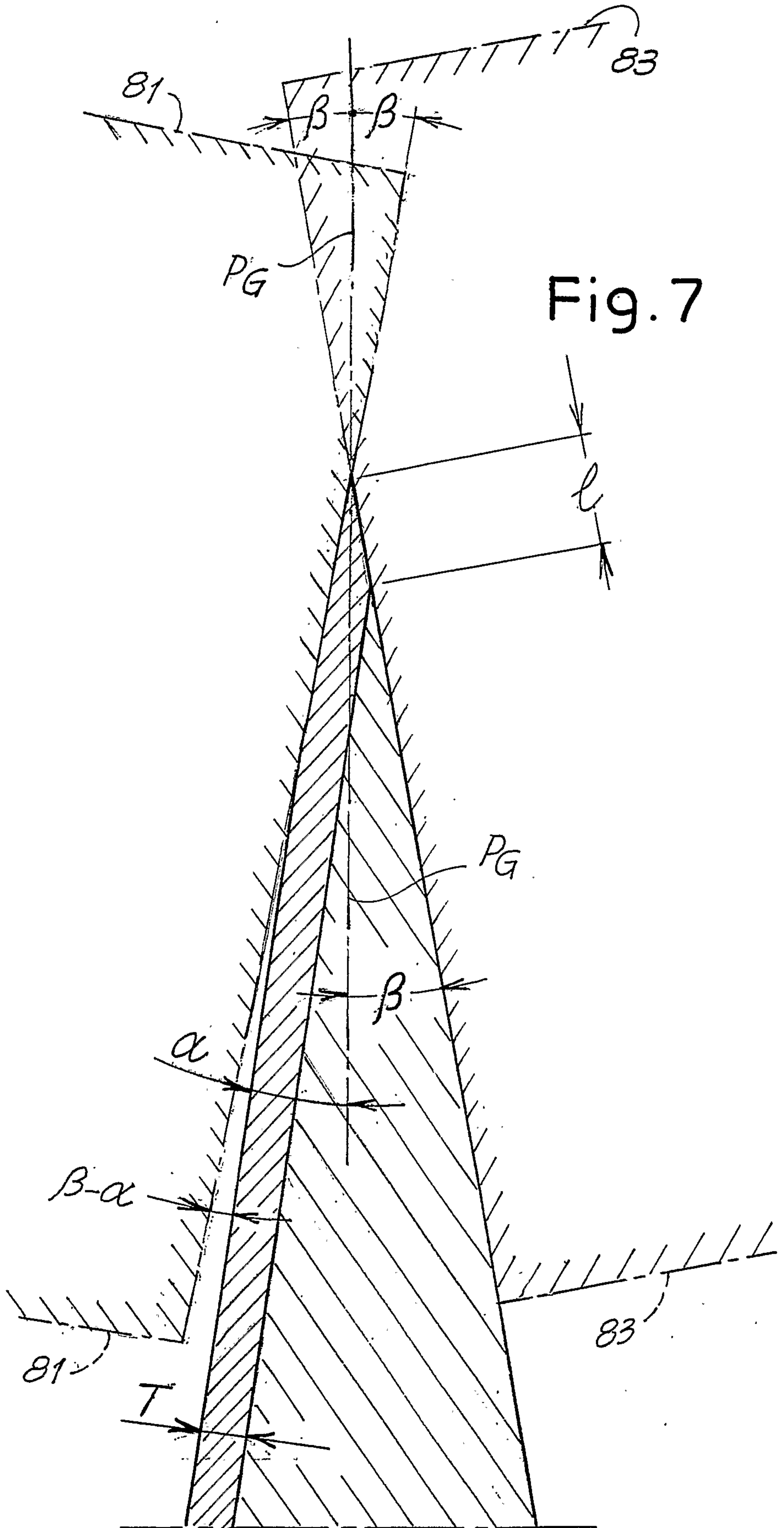
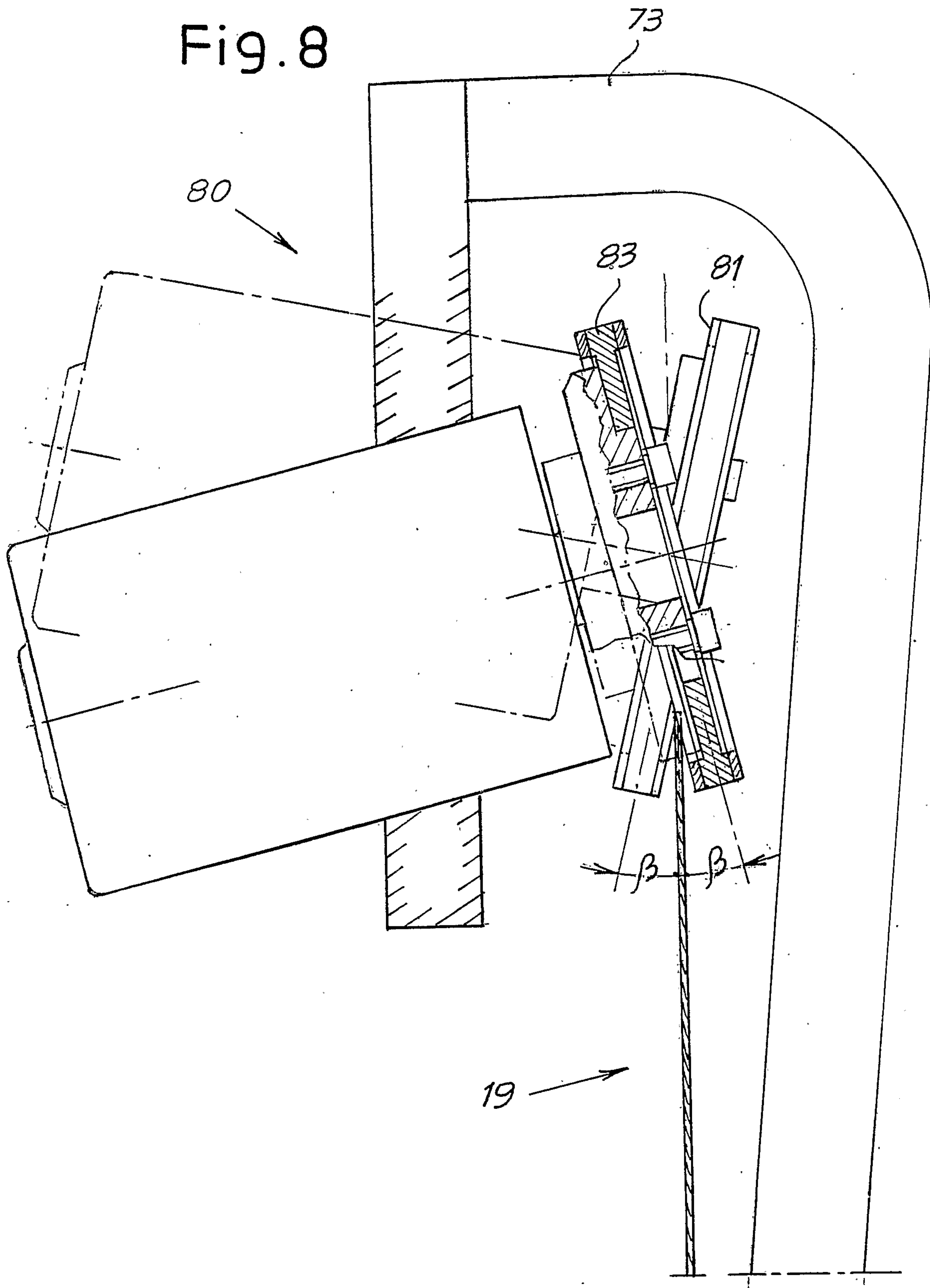

Fig. 7

8 / 10

Fig. 8



9/10

Fig. 9

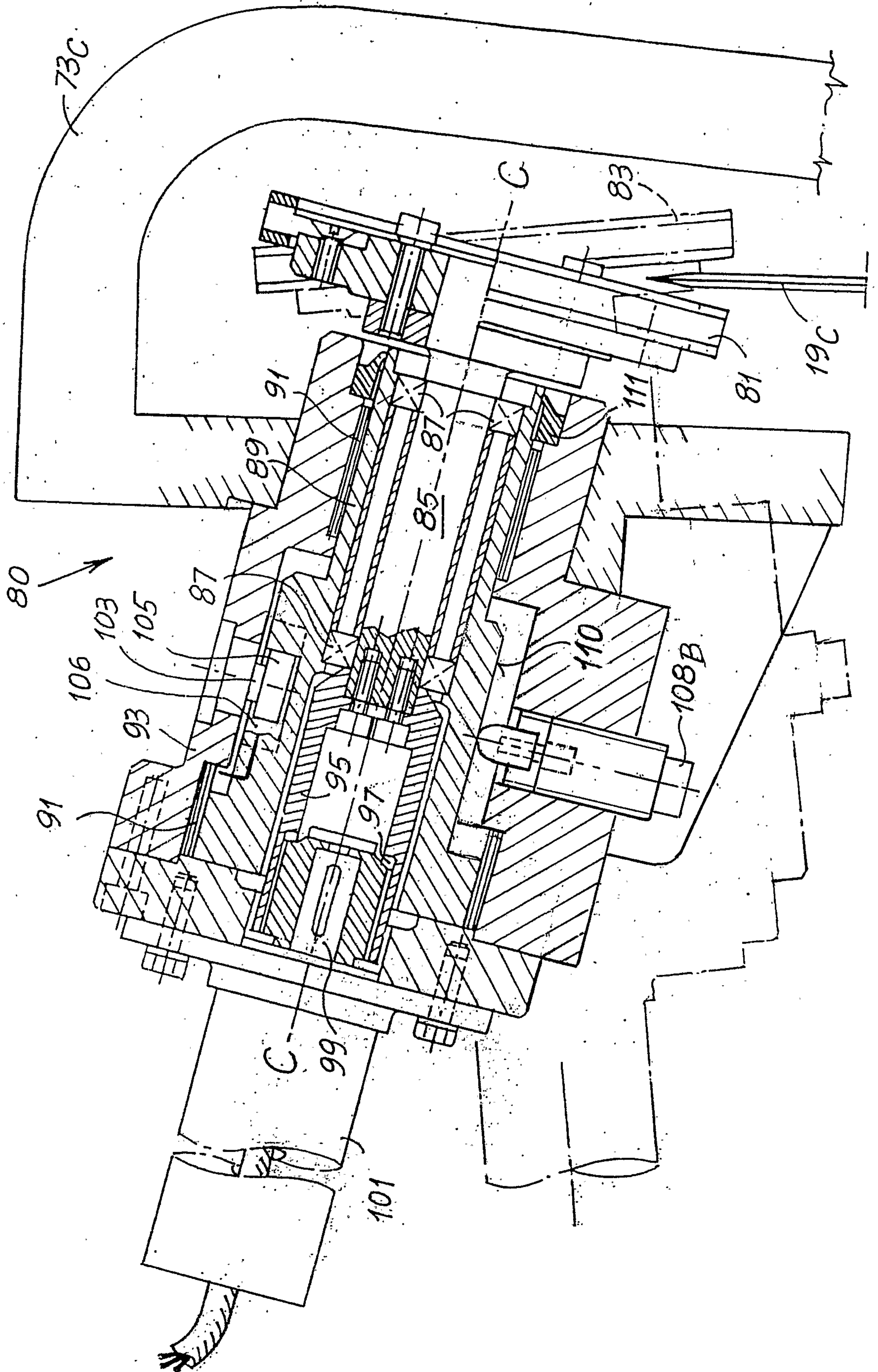

10 / 10

Fig. 10

