

(19)



(11)

EP 3 852 193 A1

(12)

EUROPEAN PATENT APPLICATION

(43) Date of publication:
21.07.2021 Bulletin 2021/29

(51) Int Cl.:
H01Q 1/24 (2006.01) H01Q 5/42 (2015.01)
H01Q 21/26 (2006.01) H01Q 9/04 (2006.01)

(21) Application number: **21152353.5**

(22) Date of filing: **19.01.2021**

(84) Designated Contracting States:
AL AT BE BG CH CY CZ DE DK EE ES FI FR GB GR HR HU IE IS IT LI LT LU LV MC MK MT NL NO PL PT RO RS SE SI SK SM TR
Designated Extension States:
BA ME KH MA MD TN

- **BISIULES, Peter J.**
LaGrange Park, Illinois 60526 (US)
- **CHEN, Changfu**
Suzhou, 215000 (CN)
- **LI, Yuemin**
Suzhou, 215000 (CN)
- **VATANKHAH VARNOOSFADERANI, Mohammad**
Richardson, Texas 75082 (US)
- **ZHANG, Jian**
Suzhou, 215000 (CN)
- **HE, Fan**
Suzhou, 215000 (CN)

(30) Priority: **20.01.2020 CN 202010061865**
12.03.2020 CN 202010168550

(71) Applicant: **CommScope Technologies LLC**
Hickory, NC 28602 (US)

(72) Inventors:
• **WU, Bo**
Suzhou, 215000 (CN)

(74) Representative: **Parker, Andrew James**
Meissner Bolte Patentanwälte
Rechtsanwälte Partnerschaft mbB
Postfach 86 06 24
81633 München (DE)

(54) **COMPACT WIDEBAND DUAL-POLARIZED RADIATING ELEMENTS FOR BASE STATION ANTENNA APPLICATIONS**

(57) Radiating elements include a conductive patch having first and second slots that each extend along a first axis and third and fourth slots that each extend along a second axis that is perpendicular to the first axis, a feed network that includes first through fourth feed lines, each

feed line crossing a respective one of the first through fourth slots, and a conductive ring that at least partially surrounds the periphery of the conductive patch and that encloses each of the first through fourth slots.

EP 3 852 193 A1

Description

CROSS-REFERENCE TO RELATED APPLICATIONS

[0001] The present application claims priority to Chinese Patent Application 202010061865.4, filed January 20, 2020, and to Chinese Patent Application 202010168550.X, filed March 12, 2020, the entire content of both of which are incorporated herein by reference.

BACKGROUND

[0002] The present invention generally relates to radio communications and, more particularly, to radiating elements for base station antennas used in cellular communications systems

[0003] Cellular communications systems are well known in the art. In a cellular communications system, a geographic area is divided into a series of regions that are referred to as "cells" which are served by respective base stations. The base station may include one or more base station antennas that are configured to provide two-way radio frequency ("RF") communications with mobile subscribers that are within the cell served by the base station. The base station antennas are often mounted on a tower, with the radiation patterns (also referred to herein as "antenna beams") that are generated by the base station antennas directed outwardly. Many cells are divided into "sectors." In perhaps the most common configuration, a hexagonally-shaped cell is divided into three 120° sectors, and each sector is served by one or more base station antennas that generate antenna beams that have an azimuth Half Power Beamwidth (HPBW) of approximately 65°. Typically, a base station antenna includes multiple phase-controlled antenna arrays that each include a plurality radiating elements that are arranged in one or more vertical columns when the antenna is mounted for use. Herein, "vertical" refers to a direction that is perpendicular to the horizontal plane that is defined by the horizon. Each antenna array generates a respective antenna beam, or two antenna beams if the antenna array is formed with dual-polarized radiating elements. The phase controlled antenna arrays include columns of radiating elements (as opposed to a single radiating element) in order to narrow the vertical or "elevation" beamwidth of the antenna beam, which may both increase the gain of the array and reduce interference with adjacent cells.

[0004] In order to accommodate the ever-increasing volume of cellular communications, cellular operators have added cellular service in a variety of new frequency bands. Cellular operators have applied a variety of approaches to support service in these new frequency bands, including increasing the number of linear arrays (or planar arrays) of radiating elements per antenna. As more columns of radiating elements are added to a typical antenna, efforts have been made to decrease the sizes of the radiating elements in order to reduce interactions

between adjacent columns of radiating elements. Additionally, as the number of radiating elements included in an antenna increases, the advantage of lowering the unit cost of the radiating elements increases.

SUMMARY

[0005] Pursuant to embodiments of the present invention, radiating elements are provided that include a conductive patch having first and second slots that each extend along a first axis and third and fourth slots that each extend along a second axis that is perpendicular to the first axis, a feed network that includes first through fourth feed lines, each feed line crossing a respective one of the first through fourth slots, and a conductive ring that at least partially surrounds a periphery of the conductive patch and that encloses each of the first through fourth slots.

[0006] In some embodiments, the conductive ring may be a continuous ring that completely surrounds the conductive patch when the radiating element is viewed in plan view.

[0007] In some embodiments, the conductive ring may have a plurality of sections, and each section may enclose a respective one of the first through fourth slots.

[0008] In some embodiments, the feed network may further include a first input, a first power divider that is coupled to the first input, a second input, and a second power divider that is coupled to the second input, and the first and second feed lines may be coupled to respective first and second outputs of the first power divider, and the third and fourth feed lines may be coupled to respective first and second outputs of the second power divider.

[0009] In some embodiments, at least a portion of the conductive patch may be implemented on a first metal layer of a printed circuit board, where the first through fourth feed lines comprise metal traces on a second metal layer of the printed circuit board, and where each of the first through fourth slots extend to the periphery of the conductive patch.

[0010] In some embodiments, the second metal layer of the printed circuit board may further include a plurality of metal pads that are each electrically connected to the conductive patch via one or more plated through holes that extend between the first and second metal layers of the printed circuit board.

[0011] In some embodiments, the conductive patch may include a first portion that is implemented on a first metal layer of a printed circuit board and a second portion that is implemented on a different metal layer of the printed circuit board. In some embodiments, the different metal layer of the printed circuit board may be the second metal layer of the printed circuit board.

[0012] In some embodiments, the conductive ring may be electrically floating. In other embodiments, the conductive ring may be electrically connected to the conductive patch. In some embodiments, the conductive ring

may be coplanar with at least a portion of the conductive patch.

[0013] Pursuant to further embodiments of the present invention, radiating elements for a base station antenna are provided that include a printed circuit board that includes a conductive patch having first and second slots that each extend along a first axis and third and fourth slots that each extend along a second axis that is perpendicular to the first axis, a first coaxial cable and a second coaxial cable that each extend from a reflector of the base station antenna to the printed circuit board, and a conductive stub that physically and electrically connects an outer conductor of the first coaxial cable to an outer conductor of the second coaxial cable.

[0014] In some embodiments, the printed circuit board may be mounted forwardly from the reflector at a distance that is greater than one-quarter of a wavelength corresponding to the center frequency of the operating frequency band of the radiating element.

[0015] In some embodiments, the conductive stub may be located at approximately one quarter of the wavelength corresponding to the center frequency of the operating frequency band of the radiating element from the printed circuit board. In some embodiments, the conductive stub may be located closer to the reflector than it is to the printed circuit board.

[0016] In some embodiments, the outer conductors of the first and second coaxial cables may be soldered to the printed circuit board.

[0017] In some embodiments, the radiating element may further include first and second conductive tubes that are positioned adjacent the first and second coaxial cables.

[0018] In some embodiments, the printed circuit board may further include a feed network that has a first input that is electrically connected to an inner conductor of the first coaxial cable, a first power divider that is coupled to the first input, first and second transmission lines that extend from the first power divider to cross the respective first and second slots, a second input that is electrically connected to an inner conductor of the second coaxial cable, a second power divider that is coupled to the second input, and third and fourth transmission lines that extend from the second power divider to cross the respective third and fourth slots.

[0019] In some embodiments, the conductive patch may be implemented at least partially on a first metal layer of the printed circuit board, where the feed network is implemented on a second metal layer of the printed circuit board, where the second metal layer further includes a plurality of metal pads that are each electrically connected to the conductive patch, and where each of the first through fourth slots extend to a periphery of the conductive patch.

[0020] Pursuant to still further embodiments of the present invention, radiating elements for a base station antenna are provided that include a printed circuit board that includes a conductive patch having first and second

slots that each extend along a first axis and third and fourth slots that each extend along a second axis that is perpendicular to the first axis and a feed stalk that mounts the printed circuit board in front of a reflector of the base station antenna. A first metal layer of the printed circuit board includes a first portion of the conductive patch and a second metal layer of the printed circuit board includes a second portion of the conductive patch.

[0021] In some embodiments, the first portion of the conductive patch may be capacitively coupled to the second portion of the conductive patch. In other embodiments, the first portion of the conductive patch may be galvanically connected to the second portion of the conductive patch.

[0022] In some embodiments, the printed circuit board may further include a feed network that includes a first input, a first power divider that is coupled to the first input, and first and second transmission lines that extend from the first power divider to cross the respective first and second slots, and a second input, a second power divider that is coupled to the second input, and third and fourth transmission lines that extend from the second power divider to cross the respective third and fourth slots.

[0023] In some embodiments, the feed network may be implemented on the second metal layer of the printed circuit board.

[0024] In some embodiments, the first portion of the conductive patch may comprise a central portion of the conductive patch and the second portion of the conductive patch may comprise a first annular-shaped metal layer having an inner portion that overlaps the central portion of the conductive patch and an exterior portion that extends outwardly beyond the central portion of the conductive patch.

[0025] In some embodiments, the conductive patch may further include a third portion that comprises a second annular-shaped metal layer having an inner portion that overlaps the first annular-shaped metal layer of the second portion of the conductive patch and an exterior portion that extends outwardly beyond the first annular-shaped metal layer of the second portion of the conductive patch.

[0026] In some embodiments, the third portion of the conductive patch may be implemented in the first metal layer.

[0027] In some embodiments, each of the first through fourth slots may extend to a periphery of the conductive patch.

[0028] Pursuant to additional embodiments of the present invention, radiating elements for a base station antenna are provided that include a conductive patch having first through fourth slots that each extend along a first axis and fifth through eighth slots that each extend along a second axis that is perpendicular to the first axis, each of the first through fourth slots extending to a periphery of the conductive patch, the first through eighth slots dividing the conductive patch into four conductive arms and a first trace that extends from the first conduc-

tive arm to the second conductive arm to separate the first slot from the second slot.

[0029] In some embodiments, a second trace that extends from the second conductive arm to the third conductive arm to separate the fifth slot from the sixth slot, a third trace that extends from the third conductive arm to the fourth conductive arm to separate the third slot from the fourth slot, and a fourth trace that extends from the fourth conductive arm to the first conductive arm to separate the seventh slot from the eighth slot.

[0030] In some embodiments, the radiating element may further include a feed stalk that mounts a printed circuit board in front of a reflector of the base station antenna.

[0031] Pursuant to further embodiments of the present invention, methods of suppressing a common mode resonance in a base station antenna are provided. The base station antenna may include at least a reflector, an array of first radiating elements that are configured to operate in a first operating frequency band and an array of second radiating elements that are configured to operate in a second operating frequency band. Each second radiating element includes a radiator unit that is positioned forwardly of the reflector and at least one coaxial feed cable that connects to the radiator unit. Pursuant to these methods, an outer conductor of a first of the coaxial feed cables that feeds a first of the second radiating elements is electrically connected to the reflector at a grounding position that is selected so that the physical distance of the RF transmission path that extends between the grounding position and the radiator unit of the first of the second radiating elements is a distance that is not resonant at any frequency in the first operating frequency band

[0032] In some embodiments, the grounding position may be a position where an outer conductor of the first of the coaxial feed cables is galvanically connected to a rear surface of the reflector. For example, the first of the coaxial feed cables may be galvanically connected to a rear surface of the reflector by exposing a portion of the outer conductor and soldering the exposed portion of the outer conductor to the reflector. The first of the coaxial feed cables may extend between the radiator unit and a printed circuit board, and the printed circuit board may include a grounding tab where a ground conductor of the printed circuit board is coupled to the reflector.

[0033] In some embodiments, the physical distance of the RF transmission path that extends between the grounding position and the radiator unit of the first of the second radiating elements may be the sum of the length of the first of the coaxial feed cables and a distance between the location where the first of the coaxially feed cables connects to the printed circuit board and the grounding tab.

[0034] The physical distance of the RF transmission path that extends between the grounding position and the radiator unit of the first of the second radiating elements may, for example, not be a multiple of a quarter wavelength of any frequency in the first operating fre-

quency band.

[0035] In some embodiments, a second of the coaxial feed cable may also feed the first of the second radiating elements, and a conductive stub may physically and electrically connect an outer conductor of the first of the coaxial feed cables to an outer conductor of the second of the coaxial feed cables. In such embodiments, the radiator unit of first of the second radiating elements may be mounted forwardly from the reflector at a distance that is greater than one-quarter of a wavelength corresponding to the center frequency of the second operating frequency band, and the conductive stub may be located at approximately one quarter of the wavelength corresponding to the center frequency of the second operating frequency band of the radiating element from the radiator unit. In some embodiments, the conductive stub may be located closer to the reflector than it is to the radiator unit.

BRIEF DESCRIPTION OF THE DRAWINGS

[0036]

FIG. 1A is a side perspective view of a base station antenna according to embodiments of the present invention.

FIG. 1B is a schematic front view of the base station antenna of **FIG. 1A** with the radome removed.

FIGS. 2A and **2B** are a side perspective view and an exploded side perspective view, respectively, of a dual-polarized radiating element according to embodiments of the present invention.

FIG. 3A is a front view of a radiator unit of the dual-polarized radiating element of **FIGS. 2A-2B**.

FIGS. 3B and **3C** are graphs of the cross-polarization discrimination performance of the radiating element of **FIG. 3A** when implemented both without and with a conductive ring.

FIGS. 4A and **4B** are front views of radiator units according to further embodiments of the present invention that may be used in place of the radiator unit of **FIG. 3A**.

FIG. 5A is a perspective rear view of a radiating element according to further embodiments of the present invention in which the outer conductors of the feed coaxial cables are soldered together.

FIGS. 5B and **5C** are simulated azimuth patterns for the radiating element of **FIG. 5A** without and with the conductive stubs, respectively.

FIGS. 5D and **5E** are graphs showing the simulated return loss for the radiating element of **FIG. 5A** without and with the conductive stubs, respectively.

FIGS. 5F and **5G** are graphs showing the simulated port-to-port isolation for the radiating element of **FIG. 5A** without and with the conductive stubs, respectively.

FIG. 6 is a perspective rear view of a radiating element according to still further embodiments of the present invention that includes a pair of metal rods

that are soldered to the feed cables.

FIG. 7 is a front view of a radiator unit according to further embodiments of the present invention.

FIG. 8 is a front view of a radiator unit according to still further embodiments of the present invention.

FIGS. 9A and **9B** are a front view and a back view, respectively, of a radiator unit printed circuit board according to further embodiments of the present invention with the feed network of the radiator unit omitted.

FIGS. 10A and **10B** are a front view and a back view, respectively, of a radiator unit printed circuit board according to still further embodiments of the present invention with the feed network omitted.

FIGS. 11A and **11B** are a front view and a back view, respectively, of a radiator unit printed circuit board according to yet additional embodiments of the present invention with the feed network of the radiator unit omitted.

FIGS. 12A and **12B** are a front view and a back view, respectively, of a radiator unit printed circuit board according to yet additional embodiments of the present invention.

FIGS. 13A and **13B** are shadow front and back views, respectively, of the radiator unit printed circuit board of **FIGS. 12A** and **12B**.

FIG. 14A is a side view of a portion of a base station antenna that includes a pair of radiating elements mounted on a reflector that are fed by a power divider printed circuit board that is mounted behind the reflector.

FIG. 14B is a rear view of the power divider printed circuit board of **FIG. 14A**.

FIG. 15A is a side view of a sheet metal based radiating element according to still further embodiments of the present invention.

FIG. 15B is a schematic view of a lower portion of one of the metal plates of the feed stalk of the radiating element of **FIG. 15A** illustrating how a feed line may be mounted thereon to form a microstrip feed line.

FIG. 15C is a front perspective shadow view of a radiator unit of the radiating element of **FIG. 15A**.

FIG. 15D is a front shadow view of the radiator unit of **FIG. 15C**.

FIG. 15E is a front shadow view of a modified version of the radiator unit of **FIGS. 15C-15D**.

FIGS. 15F and **15G** are a front perspective shadow view and a front shadow view, respectively, of another modified version of the of the radiator unit of **FIGS. 15C-15D**.

DETAILED DESCRIPTION

[0037] Pursuant to embodiments of the present invention, small, low-cost dual-polarization radiating elements are provided that are suitable for use in base station antennas. In some embodiments, the radiating elements

may be configured to operate in the 1427-2690 MHz frequency band or a portion thereof. For example, in some embodiments the radiating elements may be designed to operate in the 1695-2690 MHz frequency band. It will be appreciated, however, that the radiating elements according to embodiments of the present invention may be scaled to operate in other frequency bands. The radiating elements may exhibit high levels of port-to-port isolation, good cross-polarization discrimination, low insertion loss and suitable azimuth beamwidth performance across a wide operating frequency band.

[0038] In some embodiments, the radiating elements may include a radiator unit and a feed stalk. The feed stalk may be used to mount the radiator unit a suitable distance forwardly of a reflector of a base station antenna. The radiating element may optionally include a director and a director support. The radiator unit may comprise a conductive patch that has first and second slots that extend along a first axis and third and fourth slots that extend along a second axis that is perpendicular to the first axis. Each of the first through fourth slots may extend from a periphery of the conductive patch towards the middle or "central region" of the conductive patch, and the four slots may divide the conductive patch into four arms. Each arm may be a generally pie-shaped wedge in some embodiments, and the four arms may be electrically connected to each other in a central region of the conductive patch.

[0039] In some embodiments, the radiator unit may be implemented using a printed circuit board. In such embodiments, the printed circuit board may include a first metallization layer that includes at least a portion of a conductive patch and a second metallization layer that includes a feed network, where the two metal layers are separated by a dielectric layer. In some embodiments, the conductive patch may be implemented in its entirety on the first metallization layer of the printed circuit board, while in other embodiments, a second portion of the conductive patch may be implemented on a different metallization layer which may be the second metallization layer and/or a third metallization layer in various embodiments. In other embodiments, the conductive patch may be a sheet metal patch and any suitable feed network may be used to feed RF signals to the slots in the sheet metal patch. The conductive patch may have any appropriate shape including a circular shape, a square shape, an octagonal shape, etc. As shown in the drawings, the conductive patch may also be a variation and/or an approximation of such shapes.

[0040] The feed network may include first through fourth feed lines, where each feed line crosses a respective one of the first through fourth slots. The feed lines may be implemented as microstrip transmission lines or coplanar waveguide transmission lines in example, non-limiting embodiments. The feed network may also include a first input, a first power divider that is coupled to the first input, a second input, and a second power divider that is coupled to the second input. The first and second

feed lines may be coupled to respective first and second outputs of the first power divider, and the third and fourth feed lines may be coupled to respective first and second outputs of the second power divider.

[0041] In some embodiments, the radiator unit may further include a conductive ring that at least partially surrounds the periphery of the conductive patch and encloses each of the first through fourth slots. In some embodiments, the conductive ring may be a continuous metal ring that completely surrounds the conductive patch, while in other embodiments, the conductive ring may comprise a plurality of sections, wherein each section encloses a respective one of the first through fourth slots. The conductive ring may be electrically connected to ground or may be electrically floating. The conductive ring may capacitively load the conductive patch, which may improve the cross-polarization discrimination performance of the radiating element, particularly at lower frequencies.

[0042] In some embodiments, the feed stalk may comprise a pair of coaxial feed cables that couple respective first and second RF ports of an antenna to the radiator unit. The feed stalk may further include a structural support such as, for example, a plastic support stalk. The structural support may be used to mount the radiator unit in front of the reflector and/or to maintain the coaxial feed cables in proper position for connecting to the radiator units. In order to increase the bandwidth of the radiating element, the feed stalk may mount the radiator unit more than a quarter wavelength in front of the reflector of the base station antenna in which the radiating element is used, where the wavelength refers to the wavelength corresponding to the center frequency of the operating frequency band of the radiating element. In some embodiments, the outer conductors of the two coaxial feed cables may be soldered or otherwise electrically connected together. For example, the two outer conductors may be soldered together at a distance of approximately one quarter wavelength from the radiator unit. This may improve the port-to-port isolation performance of the radiating element. A pair of metal rods may be provided on either side of the coaxial feed cables. The rods may provide a more symmetric structure behind the radiator unit, which may help improve the port-to-port isolation performance of the radiating element.

[0043] In still other embodiments, the conductive patch may be elongated in the vertical direction, which may narrow the elevation beamwidth and/or reduce the magnitude of the grating lobes in the antenna beam formed by the radiating element. In still other embodiments, the slots in the conductive patch may extend from a center of the conductive patch outwardly, and may be closed off at the periphery of the metal patch. In yet other embodiments, four meandered traces may be used to electrically connect adjacent arms of the conductive patch near the periphery of the conductive patch.

[0044] Pursuant to still further embodiments of the present invention, techniques are provided for suppress-

ing common mode resonances that the coaxial feed cables used to feed RF signals to the above-described radiator units may generate in the responses of other nearby radiating elements that operate in different operating frequency bands. Pursuant to these techniques, the outer conductor of each coaxial feed cable may be electrically connected to a common ground reference such as the reflector of the base station antenna at a location where the length of the RF transmission path that extends between the grounding location and the radiator unit may not be a length that is resonant in the operating frequency band of other nearby radiating elements that operate in different frequency bands. The length of each RF transmission path may be the length of the coaxial feed cable plus the length of any additional path between the end of the coaxial feed cable and the grounding location. Ideally, the length of the RF transmission path that extends between the grounding location and the radiator unit may be kept as short as possible in order to reduce insertion losses, but is also selected so that the electrical length of the monopole formed by the coaxial feed cable (and other RF transmission path to the grounding location) is not resonate in the operating frequency band of the other nearby radiating elements.

[0045] Pursuant to still further embodiments of the present invention, radiating elements are provided that include a conductive patch having first and second slots that each extend along a first axis and third and fourth slots that each extend along a second axis that is perpendicular to the first axis. These radiating elements also include a feed network that includes first through fourth feed lines, each feed line crossing a respective one of the first through fourth slots. The first and second feed lines are forward of a first major surface of the conductive patch and the third and fourth feed lines are rearward of a second major surface of the conductive patch.

[0046] In some embodiment, the conductive patch may be formed of sheet metal. The radiating element may also include a metal stalk that includes first and second air microstrip transmission lines. A signal trace of the first air microstrip transmission line and the first and second feed lines may be formed as a first monolithic feed structure, and a signal trace of the second air microstrip transmission line and the third and fourth feed lines may be formed as a second monolithic feed structure. The first monolithic feed structure may extend through an opening in the conductive patch, while the second monolithic feed structure does not extend through any opening in the conductive patch. In some embodiments, outer edges of the conductive patch are bent (e.g., upwardly and/or downwardly) at an angle of at least 30° with respect to an inner portion of the conductive patch.

[0047] The radiating elements according to embodiments of the present invention may have a number of advantages. First, the radiating elements may have small physical footprints, and hence may exhibit improved column-to-column isolation. Second, the radiating elements may be inexpensive to manufacture, and may require

fewer soldered connections than many conventional radiating elements. The reduced number of solder joints may simplify assembly while also reducing the number of potential sources for passive intermodulation distortion. Additionally, the radiating elements may have very large operating frequency bands while meeting all necessary performance metrics.

[0048] Embodiments of the present invention will now be discussed in greater detail with reference to the accompanying figures.

[0049] **FIGS. 1A** and **1B** illustrate a base station antenna **10** according to certain embodiments of the present invention. In particular, **FIG. 1A** is a front perspective view of the base station antenna **10**, and **FIG. 1B** is a front view of the antenna **10** with the radome thereof removed to illustrate the inner components of the antenna. Any of the radiating elements according to embodiments of the present invention that are described herein may be used to implement the radiating elements (described below) in base station antenna **10**.

[0050] As shown in **FIG. 1A**, the base station antenna **10** is an elongated structure that extends along a longitudinal axis **L**. The base station antenna **10** may have a tubular shape with a generally rectangular cross-section. The antenna **10** includes a radome **12** and a top end cap **14**, which may or may not be integral with the radome **12**. The antenna **10** also includes a bottom end cap **16** which includes a plurality of connectors **18** mounted therein. The antenna **10** is typically mounted in a vertical configuration (i.e., the longitudinal axis **L** may be generally perpendicular to a plane defined by the horizon when the antenna **10** is mounted for normal operation).

[0051] As shown in **FIG. 1B**, the base station antenna **10** includes an antenna assembly **20** that may be slidably inserted into the radome **12**. The antenna assembly **20** includes a ground plane structure **22** that has a reflector **24**. Various mechanical and electronic components of the antenna **10** may be mounted behind the reflector **24** such as, for example, phase shifters, remote electronic tilt ("RET") units, mechanical linkages, a controller, diplexers, and the like. The reflector **24** may comprise or include a metallic surface that serves as both a reflector and as a ground plane for the radiating elements of the antenna **10**.

[0052] A plurality of dual-polarized low-band radiating elements **32** and a plurality of dual-polarized high-band radiating elements **42** are mounted to extend forwardly from the reflector **24**. The low-band radiating elements **32** are mounted in a vertical column to form a linear array **30** of low-band radiating elements **32**, and the high-band radiating elements **42** are mounted in two vertical columns to form two linear arrays **40-1**, **40-2** of high-band radiating elements **42**. The linear array **30** of low-band radiating elements **32** may be positioned between the two linear arrays **40-1**, **40-2** of high-band radiating elements **42**. Each linear array **30**, **40-1**, **40-2** may be used to form a pair of antenna beams, namely a first antenna beam having a +45° polarization and a second antenna

beam having a -45° polarization. Note that herein when multiple like elements are provided, the elements may be identified by two-part reference numerals. The full reference numeral (e.g., linear array **40-2**) may be used to refer to an individual element, while the first portion of the reference numeral (e.g., the linear arrays **40**) may be used to refer to the elements collectively.

[0053] The low-band radiating elements **32** may be configured to transmit and receive signals in a first frequency band. In some embodiments, the first frequency band may comprise the 694-960 MHz frequency range or a portion thereof. The high-band radiating elements **42** may be configured to transmit and receive signals in a second frequency band. In some embodiments, the second frequency band may comprise the 1427-2690 MHz frequency range or a portion thereof. It will be appreciated that the number of linear arrays of radiating elements may be varied from what is shown in **FIG. 1B**, as may the number of radiating elements per linear array and/or the positions of the linear arrays. It will also be appreciated that multi-column arrays may be used instead of and/or in addition to the linear arrays of radiating elements.

[0054] As noted above, embodiments of the present invention provide low cost, high performance dual-polarized radiating elements that may be used, for example, to implement each of the high-band radiating elements **42** shown in **FIG. 1B**. A first embodiment of such a dual-polarized radiating element **100** will now be described with reference to **FIGS. 2A-3C**. The radiating element **100** may be used, for example, as each of the high-band radiating elements **42** in base station antenna **10** of **FIGS. 1A-1B**.

[0055] **FIGS. 2A** and **2B** are a side perspective view and an exploded side perspective view, respectively, of a dual-polarized radiating element **100** according to embodiments of the present invention. As shown in **FIGS. 2A-2B**, the radiating element **100** includes a feed stalk **110**, a radiator unit **140**, and a director unit **190**.

[0056] The feed stalk **110** may be used to mount the radiating element **100** to extend forwardly from the reflector **24** of base station antenna **10**. The feed stalk **110** in the illustrated embodiment includes a support stalk **120** which may be made, for example, of plastic, and a pair of coaxial feed cables **130-1**, **130-2**. The radiator unit **140** may be mounted on the plastic support stalk **120** in some embodiments. The plastic support stalk **120** may include internal guide features **122** that are used to maintain the coaxial feed cables **130-1**, **130-2** in their proper positions, as well as a mounting base **124** that is used to mount the plastic support stalk **120** in openings in the reflector **24** (**FIG. 1B**) so that the plastic support stalk **120** extends forwardly from the reflector **24**. The coaxial feed cables **130-1**, **130-2** may be routed from other components of the base station antenna **10** (e.g., from electro-mechanical phase shifter assemblies) that are mounted rearwardly of the reflector **24** to the opening in the reflector **24** in which the plastic support stalk **120** is mounted.

The coaxial feed cables **130-1**, **130-2** may extend through the opening and may be routed by the guide features **122** in the support stalk **120** to the radiator unit **140**. The coaxial feed cables **130-1**, **130-2** may be physically and/or electrically connected to the radiator unit **140**. In particular, the outer conductors of the coaxial feed cables **130** may be electrically connected to a conductive patch (see **FIG. 3A**) of the radiator unit **140**, while the center conductors of coaxial feed cables **130** may be coupled to a feed network (see **FIG. 3A**) of the radiator unit **140**.

[0057] In order to increase the bandwidth of radiating element **100**, the feed stalk **110** may be designed to mount the radiator unit **140** more than a quarter wavelength in front of the reflector **24** of base station antenna **100**, where the wavelength refers to the wavelength corresponding to the center frequency of the operating frequency band of the radiating element **100**.

[0058] While the support stalk **110** of **FIGS. 2A-2B** includes a plastic support **120** and a pair of coaxial feed cables **130-1**, **130-2**, it will be appreciated that the plastic support **120** may be omitted in other embodiments, and that the coaxial feed cables **130-1**, **130-2** can be replaced with other feed structures (e.g., printed circuit board feeds, metal transmission line feeds, etc.) in still other embodiments.

[0059] The director unit **190** may comprise a director support **192** and a director **194**. The director **194** may comprise, for example, a flat piece of metal that is somewhat smaller than a conductive patch that is included in the radiator unit **140**. The director support **192** is used to mount the director **194** at a suitable height above the radiator unit **140**. The director **194** may help narrow the radiation pattern of the radiating element **100** in both the azimuth and elevation planes.

[0060] The radiator unit **140** included in radiating element **100** will now be described with reference to **FIGS. 3A-3C**. It will be appreciated, however, that a wide variety of different radiator unit designs may be used. Examples of other radiator units that may be used in place of radiator unit **140** will be discussed below with reference to **FIGS. 4A-4B** and **6-11B**.

[0061] **FIG. 3A** is a front view of the radiator unit **140** of the dual-polarized radiating element **100** of **FIGS. 2A-2B**. The radiator unit **140** may be implemented using a printed circuit board **142** that has a first metallization layer **144** and a second metallization layer **146** that are separated by a dielectric layer **148**. To simplify the drawing, the dielectric layer **148** is not shown in **FIG. 3A** (although suitable dielectric layers that could be used to implement dielectric layer **148** are shown, for example, in **FIGS. 9A-10B**), and the first and second metallization layers **144**, **146** are depicted using different colors. In some embodiments, the first metallization layer **144** may be a rear metallization layer and the second metallization layer **146** may be a front metallization layer when the radiator unit **140** is implemented in a radiating element that is mounted in a base station antenna.

[0062] As shown in **FIG. 3A**, a conductive patch **150** may be formed in the first metallization layer **144**. The conductive patch **150** may comprise a copper pattern that is formed on the rear of the dielectric layer **148** of the printed circuit board **142**. Four slots **152-1** through **152-4** are formed in the conductive patch **150** where the metallization is omitted to expose the dielectric layer **148**. Each slot **152** may extend radially from a respective point near the center of the conductive patch **150** to the periphery of the conductive patch **150**. The slots **152** may divide the conductive patch **150** into four arms **154-1** through **154-4**. Each slot **152** may be rotationally offset from adjacent slots by -90° and 90° , respectively. Thus, the first and second slots **152-1**, **152-2** may extend along a first axis **L1** and the third and fourth slots **152-3**, **152-4** may extend along a second axis **L2** that is perpendicular to the first axis **L1**. The first slot **152-1** may extend at an angle of -45° , the second slot **152-2** may extend at an angle of $+135^\circ$, the third slot **152-3** may extend at an angle of $+45^\circ$, and the fourth slot **152-4** may extend at an angle of -135° . Each of the first through fourth slots **152-1** through **152-4** may extend from a periphery of the conductive patch **150** towards the middle or "central region" of the conductive patch **150**, and the four slots **152** may divide the conductive patch **150** into the four arms **154-1** through **154-4**. Each arm **154** may be a generally pie-shaped wedge, and the four arms **154** may be electrically connected to each other in a central region of the conductive patch **150**.

[0063] As shown in **FIG. 3A**, the width of each slot **152** may be expanded at one or both ends thereof to provide enlarged slot ends **156** in some embodiments. Additionally, some of the metallization (along with the underlying dielectric material of the printed circuit board **142**) may be removed/omitted in, for example, central regions of some of the patch arms **154** to create openings **158**. Legs of the director support **192** may be mounted in these openings **158**.

[0064] The second metallization layer **146** of printed circuit board **142** may face forwardly, and may include a feed network **160** that is used to couple RF signals to and from the conductive patch **150**. The feed network **160** may include first through fourth feed lines **166-1** through **166-4**, where each feed line **166-1** through **166-4** crosses a respective one of the first through fourth slots **152-1** through **152-4**. The feed lines **166** may be implemented as microstrip transmission lines in some embodiments. As shown in **FIG. 3A**, in other embodiments, metal pads **167** may be provided on one or both sides of some or all of the feed lines **166**, and these metal pads **167** may be electrically connected to the underlying conductive patch **150** via plated through holes (not shown) that extend through the dielectric layer **148** of the printed circuit board **142**. As the conductive patch **150** is connected to ground potential, the metal pads **167** may convert the feed lines **166** from microstrip transmission lines into coplanar waveguide transmission lines. It will also be appreciated that any other suitable type of feed line

may be used including, for example, cables or strip lines or combinations of any of the above.

[0065] The feed network 160 may further include first and second inputs 162-1, 162-2 and first and second power dividers 164-1, 164-2. The inputs 162 may each comprise a metal pad. A hole 163 may extend through a center of each metal pad 162 and through the dielectric layer 148 of the printed circuit board 142 so that center conductors of the respective coaxial feed cables 130-1, 130-2 may be inserted through the printed circuit board 142 and through the respective metal pads 162-1, 162-2. The center conductors of coaxial feed cables 130-1, 130-2 may be soldered (or otherwise electrically connected) to the respective metal pads 162-1, 162-2. The outer conductors of coaxial feed cables 130-1, 130-2 may be soldered (or otherwise electrically connected) to the conductive patch 150. Each input pad 162-1, 162-2 may act as a respective power divider 164-1, 164-2 that splits an RF signal that is input to the respective input pads 162. Feed lines 166-1 and 166-2 extend from the two outputs of the first power divider 164-1 and cross the respective first and second slots 152-1, 152-2, and feed lines 166-3 and 166-4 extend from the two outputs of the second power divider 164-2 and cross the respective third and fourth slots 152-3, 152-4. In the depicted embodiment, each feed line 166-1 through 166-4 terminates into a respective one of four quarter wavelength stubs 168-1 through 168-4. As a result, RF signals that are input on feed lines 166-1 through 166-4 feed the respective slots 152-1 through 152-4. In particular, when feed lines 166-1 and 166-2 are excited, slots 152-1 and 152-2 are fed, causing the conductive patch 150 to radiate RF energy having a -45° polarization. Likewise, when feed lines 166-3 and 166-4 are excited, slots 152-3 and 152-4 are fed, causing the conductive patch 150 to radiate RF energy having a $+45^\circ$ polarization.

[0066] As is further shown in FIG. 3A, the radiator unit 140 may further include a conductive ring 170 that at least partially surrounds the periphery of the conductive patch 150 and that encloses each of the first through fourth slots 152-1 through 152-4. In the depicted embodiment, the conductive ring 170 is a thin, continuous metal ring that is implemented on the rear metallization layer 144 that completely surrounds the conductive patch 150. The conductive ring 170 may capacitively load the conductive patch 150. It has been found that this may improve the cross polarization discrimination performance of the radiating element 100. FIGS. 3B and 3C are graphs of the cross-polarization discrimination performance of radiating element 100 both with and without the conductive ring 170. As shown, without the ring (FIG. 3B), the cross-polarization discrimination is as low as 6.4 dB, whereas with the ring the cross-polarization discrimination is greater than 7.75 dB across the entire 1.695-2.690 GHz operating frequency band of the radiating element 100.

[0067] FIGS. 4A and 4B are front views of radiator units 140A, 140B, respectively, according to further embodi-

ments of the present invention that may be used in place of the radiator unit 140 of FIG. 3A. FIGS. 4A and 4B only illustrate the conductive patch 150 and the conductive rings 170A, 170B and do not illustrate the feed network to simplify the drawings. It will be appreciated that the feed network 160 of FIG. 3A may be used as the feed networks for radiator unit 140A of FIG. 4A or for radiator unit 140B of FIG. 4B. The slots 152A, 152B in conductive patches 150A, 150B have slightly different designs from the slots 152 in conductive patch 150, and the mounting holes 158 are omitted in conductive patches 150A, 150B, but otherwise the conductive patches 150, 150A and 150B are identical.

[0068] As shown in FIG. 4A, the conductive ring 170A of radiator unit 140A is identical to conductive ring 170, except that four tabs 172 are provided that electrically short the conductive ring 170A to the conductive patch 150A. As a result, the conductive ring 170A is maintained at ground potential and is not electrically floating as is the conductive ring 170 of FIG. 3A. As shown in FIG. 4B, the conductive ring 170B is similar to the conductive ring 170A, but is a discontinuous ring that includes four segments 174 that are separated by gaps 176. Each segment 174 is electrically connected to the conductive patch 150B by a pair of tabs 172.

[0069] FIG. 5A is a perspective rear view of a radiating element 200 according to further embodiments of the present invention in which the outer conductors of the feed coaxial cables are electrically connected to each other by a conductive stub.

[0070] The radiating element 200 may be identical to the radiating element 100 discussed above with one exception, which is that the outer conductors of coaxial feed cables 130-1, 130-2 are electrically connected together by a conductive stub 232 in radiating element 200. Note that various features of radiating element 200 are not shown in FIG. 5A, such as the stalk support 120 of the director unit 190.

[0071] The outer conductors of each coaxial feeder cable 130-1, 130-2 are nominally at ground potential. However, the coaxial feed cables 130-1, 130-2 may not connect to a common ground in the vicinity of radiating element 200 and, as a result, the two outer conductors may not actually be at a common potential. This difference in potential may result in unbalanced currents flowing on the coaxial feed cables 130-1, 130-2, which may degrade both the port-to-port isolation and the cross-polarization antenna pattern performance of the radiating element. As discussed above, the radiator unit 140 may be mounted more than a quarter wavelength in front of the reflector 24. This may result in unbalanced currents flowing in the coaxial feed cables 130-1, 130-2. In order to balance the currents, a conductive stub 232 is used to physically and electrically connect the outer conductors of the coaxial feed cables 130-1, 130-2. In some embodiments, the conductive stub 232 may comprise a solder joint. In other embodiments, the conductive stub 232 may comprise a conductive element that is soldered or otherwise con-

nected to the outer conductors of the coaxial feed cables **130-1**, **130-2**. In some embodiments, the conductive stub **232** may be positioned about one quarter wavelength from the radiating unit **140**.

[0072] **FIGS. 5B** and **5C** illustrate the impact of the conductive stub **232** on the antenna patterns of radiating element **200**. The "co-polarization" and "cross-polarization" antenna patterns are shown in each graph, with the different curves representing the performance at different frequencies across the operating frequency band of radiating element **200**. The co-polarization curves show the power as a function of azimuth angle that is emitted by the radiating element at the intended polarization. The cross-polarization curves show the power as a function of azimuth angle that is emitted by the radiating element at the other polarization.

[0073] As shown in **FIG. 5B**, which depicts the simulated co-polarization and cross-polarization azimuth patterns for the radiating element **200** if the conductive stub is not included, very high levels of cross-polarized signal are present in the pattern at the two lowest frequencies measured (both of which were near 1700 MHz). This level of cross-polarized signal in the pattern is not acceptable. As shown in **FIG. 5C**, which is a corresponding graph for radiating element **200** when conductive stub **232** is included, the cross-polarization levels are significantly reduced and acceptable azimuth patterns are achieved.

[0074] **FIGS. 5D** and **5E** illustrate the return loss as a function of frequency for radiating element **200** without (**FIG. 5D**) and with (**FIG. 5E**) the conductive stub **232** across the 1.695-2.690 GHz operating frequency band of the radiating element. As shown in **FIG. 5D**, without conductive stub **232**, unacceptably high levels of return loss (more than -10 dB) are seen at the lower edge of the operating frequency band. In contrast, **FIG. 5E** shows that when the conductive stub **232** is added the return loss is below -13 dB across the entire operating frequency band. **FIG. 5F** (without stub **232**) and **FIG. 5G** (with sub **232**) show that adding the conductive stub **232** also provides significant improvement in port-to-port isolation.

[0075] **FIG. 6** is a rear perspective view of a radiating element **300** according to still further embodiments of the present invention that includes a pair of metal tubes **336** that are mounted beside the pair of coaxial feed cables **130-1**, **130-2**. The radiating element **300** may be identical to the radiating element **100** discussed above with one exception, which is that two conductive tubes **336** are mounted adjacent the outer conductors of the coaxial feed cables **130-1**, **130-2**. Note that various features of radiating element **300** are not shown in **FIG. 6**, such as the stalk support **120** of the director unit **190**. The tubes **336** may increase the port-to-port isolation of the radiating element **300**. The tubes **336** may be hollow metal tubes, solid metal tubes or coaxial cables in example embodiments. The addition of the tubes **336** balances the current on all four arms of the radiating element **300**.

[0076] **FIG. 7** is a front view of a radiator unit **440** according to further embodiments of the present invention.

The radiator unit **440** can be used, for example, in the radiating element **100** of **FIGS. 2A-2B**. As shown in **FIG. 7**, the radiator unit **440** has an aspect ratio (defined here as the ratio of width to height when the radiating element including radiator unit **440** is mounted for normal use) that is less than one. This occurs because both the conductive patch **450** and the conductive ring **470** are elongated in the vertical direction.

[0077] By elongating the radiator unit **440** in the vertical direction, the distance between adjacent elements in a column of radiating elements may be reduced. This may help reduce the magnitude of grating lobes, which refer to sidelobes in the elevation pattern (and in particular at high elevation angles) that are in undesired directions. The azimuth pattern for a radiating element that includes radiator unit **440** may generally be the same as the azimuth pattern for a radiating element that includes radiator unit **110**, while the beamwidth of the main lobe in the elevation pattern for the radiating element that includes radiator unit **440** may be reduced. The improvements in elevation beamwidth and grating lobe reduction, however, have to be balanced against an expected degradation in port-to-port isolation.

[0078] **FIG. 8** is a front view of a radiator unit **540** according to still further embodiments of the present invention. The radiator unit **540** is similar to the radiator unit **140** of **FIG. 3A**, but differs in that the slots **552** extend all the way to the center of the conductive patch **550**, and the slots no longer extend to the periphery of the conductive patch **550**. The radiator unit **540** may generate similar antenna patterns as those generated by radiator unit **140**, and may also exhibit similar return loss performance. One potential difficulty with radiator unit **540** is that the center of the conductive patch **550** is not metallized, and hence there is not a convenient place to connect the coaxial feed cables **130-1**, **130-2** to the conductive patch **550**, and the transmission lines of the feed network that are in the center of the printed circuit board do not have a ground plane on the opposite side of the dielectric. Additionally, if the coaxial feed cables are mounted in the center of the conductive patch **550**, the outer conductors may negatively impact the operation of the conductive patch **550**. Thus, different feed structures (not shown) such as feed cables may be used to feed the slots **552** of conductive patch **550**.

[0079] **FIGS. 9A** and **9B** are a front view and a back view, respectively, of a radiator unit **640** (which is implemented using a printed circuit board **642**) according to further embodiments of the present invention, with the feed network of the radiator unit **640** omitted. The radiator unit **640** includes a conductive patch **650** that is implemented on two different metallization layers of the printed circuit board **642**. In particular, a first portion **651-1** of the conductive patch **650** is implemented on a rear metallization layer **644** of the printed circuit board **642**, while a second portion **651-2** of the conductive patch **650** is implemented on a front metallization layer **646** of the printed circuit board **642**. The first portion **651-1** comprises the

central portion of the conductive patch **650** and has four slots **652** therein while the second portion **651-2** comprises an outer portion of the conductive patch **650** and has an annular shape with the four slots **652** therein. The outer portion **651-2** overlaps the central portion **651-1**. In the depicted embodiment, plated through holes **659** are used to electrically connect the two portions **651** of conductive patch **650** together. In other embodiments, capacitive coupling may be used through the dielectric layer **648** of printed circuit board **642**.

[0080] A conductive ring **670** surrounds the outer portion **651-2** of the conductive patch **650**. The conductive ring **670** is formed on the front metallization layer **646** of the printed circuit board **642** in the depicted embodiment, although it may be formed on rear metallization layer **644** in other embodiments. The feed network for radiator unit **640**, which is not shown in **FIGS. 9A-9B** to simplify the drawings, may be identical (or at least substantially similar) to the feed network **160** for radiator unit **140**, and may be formed on the front metallization layer **646** of printed circuit board **642** in the interior of the annular second portion **651-2** of the conductive patch **650**.

[0081] **FIGS. 10A** and **10B** are a front view and a back view, respectively, of a radiator unit **740** (which is implemented using a printed circuit board **742**) according to still further embodiments of the present invention, with the feed network omitted. The radiator unit **740** includes a conductive patch **750** that is implemented on two different layers of the printed circuit board **742**, but in this case, the conductive patch **750** has three separate portions. The first and third portions **751-1**, **751-3** of the conductive patch **750** are implemented on a rear metallization layer **744** of the printed circuit board **742**, while the second portion **751-2** is implemented on a front metallization layer **746** of the printed circuit board **742**. The first portion **751-1** comprises the central portion of the conductive patch **750** and has four slots **752** therein, the second portion comprises a middle portion **751-2** and has an annular shape with four slots **752** therein, and the third portion comprises an outer portion **751-3** and also has an annular shape with four slots **752** therein. The middle portion **751-2** overlaps both the central portion **751-1** and the outer portion **751-3**. In the depicted embodiment, plated through holes **759** are used to electrically connect the three portions **751** of conductive patch **750** together. In other embodiments, capacitive coupling may be used through the dielectric layer of the printed circuit board **742**.

[0082] A conductive ring **770** surrounds the middle portion **751-2** of the conductive patch **750**. The conductive ring **770** is formed on the front metallization layer **746** of the printed circuit board **742** in the depicted embodiment, although it may be formed on rear metallization layer **744** in other embodiments. The feed network for radiator unit **740**, which is not shown in **FIGS. 10A-10B** to simplify the drawings, may be identical (or at least substantially similar) to the feed network **160** for radiator unit **140**, and may be formed on the front metallization layer **746** of

printed circuit board **742** in the interior of the annular second portion **751-2** of the conductive patch **750**.

[0083] **FIGS. 11A** and **11B** are a front view and a back view, respectively, of a radiator unit **840** (which is implemented using a printed circuit board) according to still further embodiments of the present invention, with the feed network again omitted. Radiator unit **840** is similar to radiator unit **140** discussed above, except that adjacent arms **854** of radiator unit **840** are electrically connected to each other by meandered traces **855** near the periphery of the conductive patch **850**. As a result, the conductive patch **850** includes a total of eight slots therein, namely four inner slots **852-1** through **852-4** and four outer slots **852-5** through **852-8**. As shown in **FIG. 11B**, on the front metallization layer **846** of the printed circuit board, four metal pads **857** are provided that overlap the meandered traces **855**. As a result, the combination of a meandered trace **855** and its corresponding overlapping metal pad **857** acts like a filtered connection between the two adjacent arms **854**.

[0084] It will be appreciated that the above-described radiating elements according to embodiments of the present invention may be combined in any way to provide many additional embodiments. For example, the conductive stub **232** of radiating element **200** and/or the conductive tubes **336** of radiating element **300** may be included in any of the other radiating elements described herein. Similarly, the conductive ring structures of **FIGS. 4A** or **4B** may be used to replace the conductive rings of any of the other embodiments, or the conductive ring may be omitted in its entirety. Any of the radiator units described herein may be elongated vertically like the radiator unit **440** of **FIG. 7**, and/or the slot design for any of the conductive patches may be modified to have the slot design of the conductive patch **550** of **FIG. 8**. Additionally, any of the conductive patches may be implemented as multi-layer conductive patches as shown in **FIGS. 9A-10B**, or may include the filters that are provided in the conductive patch **850** of **FIGS. 11A-11B**. All such embodiments are considered to be within the scope of the present invention. It will also be appreciated that this specification only describes a few example embodiments, and that many changes may be made thereto without departing from the scope of the present invention.

[0085] **FIGS. 12A** and **12B** are front and rear views, respectively, of another alternative radiator unit **940** that may be used in place of the radiator unit **140** of the dual-polarized radiating element **100** of **FIGS. 2A-2B**. The radiator unit **940** may comprise a printed circuit board **942** that has a first metallization layer **944** and a second metallization layer **946** that are separated by a dielectric layer **948**. In the depicted embodiment, the first metallization layer **944** is the rear metallization layer (**FIG. 12B**) and the second metallization layer **946** is the front metallization layer (**FIG. 12A**).

[0086] Similar to the radiator unit **140** discussed above with reference to **FIG. 3A**, the radiator unit **940** includes a conductive patch **950** that is implemented in the rear

metallization layer **944** of printed circuit board **942**. Four radial slots **952-1** through **952-4** are formed in conductive patch **950**, with each slot **952** extending outwardly from near the center of the conductive patch **950**. Each slot **952** comprises a region where the rear layer metallization is omitted (or removed) to expose the dielectric layer **948** of printed circuit board **942**. Each slot **952** may be rotationally offset from adjacent slots **952** by -90° and 90° , respectively. As shown in **FIG. 12B**, the four slots **952** divide the conductive patch **950** into four arms **954-1** through **954-4**. Each arm **954** of the conductive patch **950** has a generally T-shaped region where the metallization is omitted to form respective openings **958**, which extend inwardly from the outer edge of the respective arms **954**. The four arms **954** connect to each other in the central region of the conductive patch **950**. A conductive ring **970** surrounds the conductive patch **950**. The conductive ring **970** is formed on the rear metallization layer **944** in the depicted embodiment, although it may be formed on front metallization layer **944** in other embodiments. The conductive ring **970** may be identical to the conductive ring **170** of radiator unit **140**. In other embodiments, part of the conductive ring **970** may be formed in the front metallization layer **946** and the remainder may be formed in the rear metallization layer **944**.

[0087] The outer conductors of the two feed cables **130-1**, **130-2** (**FIGS. 2A-2B**) may be soldered to the conductive patch **950** in the central region of conductive patch **950**. A ringshaped (annular) solder mask **951** may be formed on the conductive patch **950** as shown in **FIG. 12B**. The conductive patch **950** includes a pair of central openings **963** that receive the center conductors of the feed cables **130-1**, **130-2** so that the center conductors may pass through the dielectric substrate **948** to be electrically connected to a feed network **960** that is formed in the front metallization layer **946**. The center conductors of the two feed cables **130-1**, **130-2** are electrically isolated from the conductive patch **950**.

[0088] Referring to **FIG. 12A**, the front metallization layer **946** of printed circuit board **942** includes the feed network **960**, which is used to couple RF signals to and from the conductive patch **950**. The feed network **960** may be similar to or identical to the feed network **160** discussed above with reference to **FIG. 3A**, and hence further description thereof will be omitted here. A solder mask **962** may be formed on the central region of the feed network **960** to facilitate soldering the center conductors of the feed cables **130-1**, **130-2** to the inputs of the feed network **960**. As is shown in **FIG. 12A**, the front metallization layer **946** may further include four conductive plates **959** that together form a broken annular ring. The broken annular ring may generally surround the feed network **960**. Each conductive plate **959** may overlap a respective one of the T-shaped openings **958** in the arms **954** of the conductive patch **950**. The conductive plates **959** may capacitively couple with the underlying conductive patch **950**.

[0089] **FIGS. 13A** and **13B** are shadow front and back

views, respectively, of the radiator unit printed circuit board **942** of **FIGS. 12A** and **12B**. The solder masks **951**, **962** that are shown in the middle of **FIGS. 12A-12B** are omitted in **FIGS. 13A-13B** to better illustrate the rear and front metallization layers **944**, **946**.

[0090] The radiator unit **940** of **FIGS. 12A-13B** may have the general design of the radiator unit disclosed in **FIGS. 7-8** of U.S. Patent No. 7,688,271. In particular, referring to **FIGS. 13A-13B**, it can be seen that each arm **954** of conductive patch **950** includes a first half **954A** and a second half **954B** that comprise respective first and second legs **954A**, **954B** that extend radially outwardly from the central region of the printed circuit board **942**. Each pair of a first leg **954A** of a first arm **954** and an adjacent second leg **954B** of an adjacent second arm **954** together form a generally T-shaped dipole radiator **953**, as can be seen in the dashed box in **FIG. 13B**. Each slot **952** separates the first and second legs **954A**, **954B** of a respective one of the dipole radiators **953**. The four dipole radiators **953** form a dipole square that has a generally octagonal profile. As with the radiator unit disclosed in **FIGS. 7-8** of U.S. Patent No. 7,688,271, each dipole radiator **953** is fed by a respective hook shaped feed line **966** that crosses the respective slot **952** of the dipole radiator **953** on the opposite side of the printed circuit board **942**.

[0091] There are several differences between the radiator unit disclosed in **FIGS. 7-8** of U.S. Patent No. 7,688,271 and the radiator unit **940** of **FIGS. 12A-13B**. For example, in radiator unit **940**, the feed network **960** is implemented on the front metallization layer **946** and the dipole radiators **953** are implemented on the rear metallization layer **944**, which is the reverse of what is shown in U.S. Patent No. 7,688,271. As another example, in U.S. Patent No. 7,688,271 the openings in each arm of the conductive patch where the metallization is removed are generally diamond-shaped as compared to the generally T-shaped openings **958** included in the arms **954** of radiator unit **940**. As another example, the radiator unit **940** includes the conductive plates **959** that are formed on the front metallization layer **944**, which are not provided in the radiator unit of U.S. Patent No. 7,688,271. Additionally, U.S. Patent No. 7,688,271 uses a printed circuit board-based feed stalk to feed the RF signals to and from the radiator unit thereof, while the radiator unit **940** is designed to be fed directly by a pair of coaxial cables **130-1**, **130-2**.

[0092] Pursuant to further embodiments of the present invention, techniques for grounding radiating elements are provided that may be used to suppress a common mode resonance that may distort the radiation pattern of nearby radiating elements that operate in a different frequency band. These techniques may be used, for example, with any of the radiating elements according to embodiments of the present invention that are disclosed herein. As described above, coaxial feed cables may be used as the feed elements for the radiating elements according to embodiments of the present invention. As is

also described above, in some embodiments, the outer conductors of the coaxial feed cables **130** may not be coupled to the reflector **24** underneath the radiating elements, but instead may be coupled to the reflector **24** elsewhere within the antenna. As a result, the outer conductors of the coaxial feed cables **130** may appear as a monopole element that has a length equal to the distance from where the outer conductor of each coaxial feed cable **130** is grounded to the reflector **24** at the point where the coaxial feed cable **130** connects to one of the radiator units (e.g., radiator unit **140**) according to embodiments of the present invention. If the monopole element formed by the outer conductor of a coaxial feed cable **130** has a length that is resonant within an operating frequency band of other radiating elements that may be included in the base station antenna, then the coaxial feed cables **130** may generate common mode resonances in the response of these other radiating elements, degrading the performance thereof.

[0093] Pursuant to embodiments of the present invention, the points where the outer conductors of the coaxial feed cables **130** for a radiating element are coupled to a common ground reference such as the reflector of an antenna may be selected so that common mode resonances will not be generated in the response of other radiating elements included in the antenna. In particular, the length of the "monopole" segment of each coaxial feed cable that extends from the radiator unit that the coaxial feed cable **130** feeds to the point where the coaxial feed cable **130** is connected to a common ground reference (e.g., the reflector **24**) may be set to be a length that will not resonate in the operating frequency band of any other nearby radiating elements. Thus, for example, if the coaxial feed cables are used to feed so-called high band radiating elements that operate in the 1,695-2,690 MHz frequency band that are mounted adjacent other so-called low-band radiating elements that operate in the 696-960 MHz frequency band, then the lengths of the above-described "monopole" segments of the coaxial feed cables **130** will be selected so that they are not resonant in the 696-960 MHz frequency band (e.g., the lengths of the monopole segments will not be equal to a quarter wavelength, a half, wavelength, three quarters of a wavelength, one wavelength, etc. for any frequency within the 696-960 MHz frequency band). This technique may be used to suppress a common mode resonance that otherwise could degrade the performance of the low band radiating elements.

[0094] FIG. **14A** is a side view of a portion of a base station antenna that includes a pair of radiating elements mounted on a reflector that are fed by a power divider printed circuit board that is mounted behind the reflector. FIG. **14B** is a rear view of the power divider printed circuit board of FIG. **14A**. FIGS. **14A** and **14B** will be used to explain how the above-described common mode resonances can be suppressed in nearby radiating elements that operate in different frequency bands.

[0095] As shown in FIG. **14A**, the base station antenna

includes a reflector **1000** and first and second radiating elements **1010-1**, **1010-2** that are mounted to extend forwardly from the reflector **1000**. The first radiating element **1010-1** is fed by a first pair of coaxial feed cables **1030-1**, **1030-2**. The second radiating element **1010-2** is fed by a second pair of coaxial feed cables **1030-3**, **1030-4**. A power divider printed circuit board **1050** is mounted on the rear side of the reflector **1000**.

[0096] As shown in FIG. **14B**, the power divider printed circuit board **1050** includes first and second input ports **1052-1**, **1052-2**, and first through fourth output ports **1054-1** through **1054-4**. First and second input coaxial cables **1060-1**, **1060-2** are coupled to the respective first and second input ports **1052-1**, **1052-2**. The coaxial feed cables **1030-1**, **1030-2** for the first radiating element **1010-1** are coupled to the respective first and second output ports **1054-1**, **1054-2**. The coaxial feed cables **1030-3**, **1030-4** for the second radiating element **1010-2** are coupled to the respective third and fourth output ports **1054-3**, **1054-4**. The power divider printed circuit board **1050** may include transmission lines **1056** such as, for example, microstrip transmission lines and a pair of power divider circuits such as, for example, Wilkinson power dividers **1058**. A first transmission line **1056-1** may connect the first input port **1052-1** to an input of the first power divider circuit **1058-1** and third and fourth transmission lines **1056-3**, **1056-4** may connect the first and second outputs of the first power divider circuit **1058-1** to the respective first and second output ports **1054-1**, **1054-2**. Similarly, a second transmission line **1056-2** may connect the second input port **1052-2** to an input of the second power divider circuit **1058-2** and fifth and sixth transmission lines **1056-5**, **1056-6** may connect the first and second outputs of the second power divider circuit **1058-2** to the respective third and fourth output ports **1054-3**, **1054-4**.

[0097] As is further shown in FIG. **14B**, the power divider printed circuit board **1050** may include one or more grounding tabs **1059** where a ground reference for the transmission lines **1056** is coupled to the reflector **1000**. The grounding tabs **1059** may comprise an electrical connection (which may be a galvanic connection or a capacitive connection, for example) between the ground reference for the transmission lines **1056** and the reflector **1000**.

[0098] As shown in FIG. **14A**, a first segment **1032** of each coaxial feed cable **1030** extends forwardly from the reflector **1000** to the radiator unit **1040** of its associated radiating element **1010**. The length of each first segment **1032** may be **L1**, which is typically between a quarter wavelength and three-eighths of a wavelength of the center frequency of the operating frequency band of the radiating element **1010**. These segments **1032** may appear as monopoles that extend forwardly from the reflector/ground plane **1000**. Each coaxial feed cable **1030** includes a second segment **1034** that extends along the back side the reflector **1000** from the distal end of the first segment **1032** to the power divider printed circuit

board **1050**. The length of each second segment **1034** may be **L2**, and the length **L2** may be selected by an antenna designed based on the location of the power divider printed circuit board **1050**. As shown in **FIG. 14B**, each output port **1054** on power divider printed circuit board **1050** may be located a distance **L3** from the closest ground tab **1059** (note that the distance **L3** may be different for each output port **1054**).

[0099] RF energy emitted by another radiating element **1070** that operates in a different frequency band may be present in the vicinity of the first segments **1032** of the coaxial feed cables **1030**. As noted above, the first segments **1032** of the coaxial feed cables **1030** may appear as monopole elements that extend forwardly from the reflector **1000**. Moreover, since each coaxial feed cable **1030** has a ground connection to the reflector **1000** at one of the grounding tabs **1059**, the effective length of these monopole elements is not the length **L1** of the first segments **1032** that extend forwardly from the reflector **1000**, but instead is the sum of **L1 + L2 + L3** for each coaxial feed cable **1030**. If this effective length is a length that is resonant within the operating frequency band of the radiating element **1070**, then the RF energy emitted by radiating element **1070** may induce currents on the coaxial feed cables **1030**, generating the common mode resonance in the frequency response of the radiating element **1070**. This common mode resonance will occur in a relatively tight range of frequencies for which the effective length of the monopole element is resonant within the operating frequency band of radiating element **1070**. Unfortunately, this common mode resonance can degrade the performance of radiating element **1070**.

[0100] An antenna designer may select the distance **L2** based on the location of the power divider printed circuit board **1050** with respect to the radiating elements **1010**, and may select the distance **L3** based on the size of the power divider printed circuit board and the locations of the grounding tabs **1059** and the output ports **1054**. As such, the antenna designer can select the effective length of the monopole element formed by each coaxial feed cable **1030**. By selecting these effective lengths to not be lengths where the monopole elements will be resonant in the operating frequency band(s) of other nearby radiating elements, the generation of a common mode resonance in the response of the nearby radiating elements may be suppressed.

[0101] While **FIGS. 14A** and **14B** illustrate an example where the radiating elements **1010-1**, **1010-2** are fed through a power divider printed circuit board **1050**, it will be appreciated that embodiments of the present invention are not limited thereto. For example, in other embodiments, the coaxial feed cables **1030** may connect to a phase shifter or other circuit element that may or may not include a grounding tab. Moreover, if a grounding tab is not provided, the coaxial feed cables may be grounded to the reflector in other ways. For example, a small portion of the cable jacket of each coaxial feed cable **1030** may be removed and the outer conductor of each coaxial feed

cable **1030** that is exposed through the opening in the cable jacket may be soldered to the reflector **1000** to provide the ground reference. When this approach is taken, the effective length of each monopole element may be **L1 + L2**, where **L2** is the length of the second cable segment **1034** that extends between cable segment **1032** and the point where the coaxial feed cable **1030** is soldered to the reflector **1000**.

[0102] The radiating elements discussed above have primarily been implemented using radiator unit printed circuit boards having two metal layers, with a conductive patch of the radiating element implemented at least primarily on one metal layer and the feed network implemented primarily on the other layer of the printed circuit board. Embodiments of the present invention, however, are not limited thereto. For example, **FIGS. 15A-15D** illustrate a radiating element **1100** according to further embodiments of the present invention that is implemented primarily from sheet metal. Sheet metal radiating elements may be cheaper than corresponding printed circuit board based radiating elements, and allow for three-dimensional radiator units that may have a smaller size or "footprint" on the reflector of the antenna. This smaller footprint may allow an array formed of the radiating elements to be positioned closer to other arrays of radiating elements, allowing for a reduction in the size of an antenna including these radiating elements and/or the inclusion of more arrays in the antenna.

[0103] Referring first to **FIGS. 15A-15B**, **FIG. 15A** is a side view of the sheet metal based radiating element **1100**, while **FIG. 15B** is a schematic view of a lower portion of one of the metal plates of the feed stalk of the radiating element of **FIG. 15A** illustrating how a feed line may be mounted thereon to form a microstrip feed line.

[0104] As shown in **FIGS. 15A-15B**, the radiating element **1100** includes a feed stalk **1110** and a radiator unit **1140**. The feed stalk **1110** is used to mount the radiator unit **1140** forwardly of the reflector (not shown) of a base station antenna. The feed stalk **1110** includes an L-shaped metal stalk **1120** and a pair of traces **1132-1**, **1132-2**. It will be appreciated that the metal feed stalk **1120** may have other shapes (cross-sections) such as, for example, square shape, triangular shape, cruciform shape, etc. Each trace **1132** is part of a larger feed structure **1130**, as will be discussed below. The L-shaped metal stalk **1120** includes first and second metal plates **1122-1**, **1122-2**, which may comprise a single piece of metal that is bent at a 90° angle to define the two plates **1122-1**, **1122-2**. The first trace **1132-1** is mounted on the first metal plate **1122-1** and the second trace **1132-2** is mounted on the second metal plate **1122-2** so as to form first and second microstrip transmission lines **1124-1**, **1124-2**, with the metal plates **1122** serving as the ground conductors of the microstrip transmission lines **1124** and the traces **1132** serving as the signal traces of the respective microstrip transmission lines **1124**.

[0105] As shown in **FIG. 15B**, the traces **1132** may be mounted on the respective metal plates **1122** using, for

example, dielectric stand-off rivets **1126** that mount each trace **1132** at a predetermined distance from its associated metal plate **1122**, where the predetermined distance may be selected so that the microstrip transmission lines **1124** may have a desired impedance. The traces **1132** may have features **1134** such as widened areas and or openings that mate with the dielectric stand-off rivets **1126** that facilitate mounting the traces **1132** to the metal plates **1122** and maintaining the desired impedance. As shown in **FIG. 15B**, a rear portion of each metal plate **1122** may be bent at a 90° angle (other angles may be used; preferably an angle of at least 30° is used to obtain a significant reduction in the size of the radiating element) to form a tab **1128** that facilitates mounting the metal stalk **1120** to extend forwardly from a reflector **24** using dielectric rivets **1127**. A dielectric pad **25** may be interposed between the reflector **24** and the tab **1128**. Alternatively, metal rivets may be used and the dielectric pad **25** may be omitted to provide a galvanic connection instead of a capacitive connection between the metal stalk **1120** and the reflector **24**. First and second coaxial feed cables (not shown) may be electrically coupled to the microstrip transmission lines **1124**. For example, the outer (ground) conductor of each coaxial feed cable may be soldered to the reflector **24** and capacitively coupled to the metal stalk **1120** through the dielectric pads **25**, and the traces **1132** may extend rearwardly through openings **26** in the reflector **24** so that the inner conductors of the respective first and second coaxial feed cables may be soldered to the rear end of each trace **1132** behind the reflector **24**. The first and second coaxial feed cables may connect the radiating element **1100** to another component of a base station antenna such as an electromechanical phase shifter assembly or a power divider.

[0106] While the feed stalk **1110** of **FIGS. 15A-15B** comprises a metal stalk **1120** and a pair of traces **1132-1**, **1132-2**, it will be appreciated that in other embodiments other types of feed stalks may be used such as, for example, coaxial feed cables, printed circuit board feeds, etc.).

[0107] **FIGS. 15C** and **15D** are a front perspective shadow and a front shadow view, respectively, of a radiator unit **1140** of the radiating element **1100** of **FIG. 15A**. Referring to **FIGS. 15C-15D**, the radiator unit **1140** may be mounted on a forward end of metal stalk **1120** via, for example, soldering. The radiator unit **1140** may be implemented using pieces of stamped sheet metal and four small printed circuit boards. A first piece of sheet metal **1142** may form a conductive patch **1150**. The first piece of sheet metal **1142** may have a square shape and may be formed by stamping the square piece of sheet metal **1142** to form a plurality of slots **1152**, **1154** therein, and then bending the four outer edges **1156** of the piece of sheet metal **1142** upward at an angle of about 90° (**FIGS. 15A** and **15C**). The four outer edges **1156** may be bent downwardly in other embodiments, or some of the outer edges **1156** may be bent upwardly and others downwardly. The outer edges **1156** may each be bent at

an angle of at least 30°, or at an angle of at least 45°, or at an angle of at least 60°. In some embodiments, the outer edges **1156** may each be bent at an angle of approximately 90° with respect to the inner portions of the arms **1154**. Slots **1152-1** through **1152-4** extend radially from a respective point near the center of the first piece of sheet metal **1142** to the periphery of the conductive patch **1150**. Each of the first through fourth slots **1152-1** through **1152-4** includes a first portion that extends in a plane defined by an inner portion (the central region) of the conductive patch **1150**, and a second portion that extends at an oblique angle with respect to the first portion. Each slot **1152** may be rotationally offset from adjacent slots by -90° and 90°, respectively. The slots **1152** extend through the upwardly bent outer edges **1156** of the square piece of sheet metal **1142**, and hence each slot **1152** extends to the periphery of the conductive patch **1150**.

[0108] The first and second slots **1152-1**, **1152-2** may extend along a first common plane and the third and fourth slots **1152-3**, **1152-4** may extend along a second common plane that is perpendicular to the first common plane. Each of the slots **1152** may extend from a periphery of the conductive patch **1150** towards the middle or "central region" of the conductive patch **1150**, and the four slots **1152** may divide the conductive patch **1150** into the four arms **1154-1** through **1154-4**. The four arms **1154** are electrically connected to each other in a central region of the conductive patch **1150** and extend outwardly from the central region of the conductive patch **1150**.

[0109] Openings in the form of slots **1158-1** through **1158-4** are formed in the respective upwardly bent outer edges **1156** of the square piece of sheet metal **1142**. Thus, a slot **1158** is formed in each arm **1154**. The slots **1158** may be generally T-shaped slots in some embodiments, as shown. Each slot **1158** may extend to a distal portion of a respective arm **1154**. Four small printed circuit boards **1144** are provided. Each printed circuit board **1144** includes a dielectric substrate (not shown) that directly contacts a respective one of the upwardly bent outer edges **1156** of the square piece of sheet metal **1142**, and a metal layer formed on the outer side of dielectric substrate. Each printed circuit board **1144** overlaps a respective one of the upwardly bent outer edges of the square piece of sheet metal **1142**. The printed circuit boards **1144** may be attached to the upwardly bent outer edges **1156** of the square piece of sheet metal **1142** be any appropriate fashion including, for example, adhesives, double-sided tapes, rivets, screws or other fasteners. Each printed circuit board **1144** may cover a respective one of the slots **1158**. In other embodiments, the printed circuit boards **1144** may be replaced with metal sheets that may be attached to the upwardly bent outer edges **1156** of the square piece of sheet metal **1142** via adhesive tape or other means that allow the metal sheets to capacitively couple to the upwardly bent outer edges **1156** of the square piece of sheet metal **1142**. Each metal layer (whether in the form of a metal layer on a printed

circuit board **1144** or a metal sheet) may capacitively couple with the outer edge **1156** of a respective one of the arms **1154**.

[0110] As noted above, the traces **1132-1**, **1132-2** are each part of a respective feed structure **1130-1**, **1130-2**. Each feed structure **1130-1**, **1130-2** may comprise a monolithic piece of stamped and bent sheet metal. Feed structure **1130-1** includes first and second feed lines **1166-1**, **1166-2**, while feed structure **1130-2** includes third and fourth feed lines **1166-3**, **1166-4**. Thus, the first and second feed lines **1166-1**, **1166-2** are physically and electrically connected to the first trace **1132-1**, and the third and fourth feed lines **1166-3**, **1166-4** are electrically connected to the second trace **1132-2**.

[0111] Feed line **1166-1** crosses the first slot **1152-1** and feed line **1166-2** crosses the second slot **1152-2**. Accordingly, RF signals that are incident on the first trace **1132-1** split so that a portion of the RF energy passes to each of the first and second feed lines **1166-1**, **1166-2**. Feed line **1166-3** crosses the third slot **1152-3** and feed line **1166-4** crosses the fourth slot **1152-4**. Thus, RF signals that are incident on the second trace **1132-2** split so that a portion of the RF energy passes to each of the third and fourth feed lines **1166-3**, **1166-4**. The RF energy passes along each feed line **1166** to cross a respective one of the slots **1152**. Each feed line **1166** terminates into a respective one of four quarter wavelength stubs **1168**. As a result, RF signals that are input on feed lines **1166-1** through **1166-4** feed the respective slots **1152-1** through **1152-4**, causing the conductive patch **1150** to radiate RF energy.

[0112] The first and second feed lines **1166-1**, **1166-2** are positioned forwardly of the conductive patch **1150**, as can best be seen in **FIG. 15A**. The third and fourth feed lines **1166-3**, **1166-4** are positioned rearward of the conductive patch **1150**. A pair of dielectric spacers (not shown) are provided, the first of which is interposed between the first and second feed lines **1166-1**, **1166-2** and the conductive patch **1150**, and the second of which is interposed between the third and fourth feed lines **1166-3**, **1166-4** and the conductive patch **1150**. The dielectric spacers may physically and electrically separate the first and second feed structures **1130-1**, **1130-2** from the first piece of metal **1142**. Each feed line **1166** may comprise an air microstrip transmission line. In other embodiments, the feed lines **1166** may comprise conventional microstrip transmission lines.

[0113] It will be appreciated that many modifications may be made to the radiating element **1100** of **FIGS. 15A-15D**. For example, **FIG. 15E** is a front shadow view of a modified version of a radiator unit **1140'** that may be used in place of the radiator unit **1140** in the radiating element **1100**. The radiator unit **1140'** may be identical to the radiator unit **1140** of **FIGS. 15C-15D** except that the outer edges **1156** of radiator unit **1140'** are not bent upwardly or downwardly so that the conductive patch **1150** is a planar element.

[0114] **FIGS. 15F** and **15G** are a front perspective

shadow view and a front shadow view, respectively, of another modified version **1140''** of the radiator unit of **FIGS. 15C-15D**. As shown in **FIGS. 15F** and **15G**, the radiator unit **1140''** is identical to the radiator unit **1140** except that the base of the T-shaped slots **1158** is extended so that the slots **1158** extend farther into the interior of the conductive patch **1150**.

[0115] Notably, positioning the first and second feed lines **1166-1**, **1166-2** on one side of the conductive patch **1150** while positioning the third and fourth feed lines **1166-3**, **1166-4** on the other side of the conductive patch **1150** eliminates any need to provide special structures to prevent conductive lines **1166-1** and **1166-3** from electrically short-circuiting at the location where they "cross" when viewed from the front. However, it will be understood that all of the feed lines **1166** may be implemented on the same side (either front or back) of the conductive patch **1150** in other embodiments, as shown above with respect to other radiating elements according to embodiments of the present invention.

[0116] While monolithic sheet metal feed structures **1130-1**, **1130-2** are used in the depicted embodiment, it will be appreciated that in other embodiments the first and second feed lines **1166-1**, **1166-2** may be implemented using a first printed circuit board, and that the third and fourth feed lines **1166-3**, **1166-4** may be implemented using a second printed circuit board. The traces **1132-1**, **1132-2** may be electrically coupled to the respective printed circuit boards. If printed circuit boards are used, the feed branches may be implemented as coplanar waveguide or grounded coplanar waveguide transmission lines in the same manner discussed above with other embodiments of the present invention.

[0117] Bending the outer edges of the first piece of stamped metal **1142** may reduce the "footprint" of the radiating element **1100** (i.e., the area of the radiating element **1100** when viewed from the front). This may allow an array of radiating elements **1100** included in an antenna to be positioned closer to other arrays. As the radiating element **1100** may be formed primarily of stamped sheet metal it may be cheaper to fabricate than comparable radiating elements formed using printed circuit boards.

[0118] In one example embodiment of the present invention, a radiating element is provided that includes a conductive patch having first and second slots that each extend along a first axis and third and fourth slots that each extend along a second axis that is perpendicular to the first axis; a feed network that includes first through fourth feed lines, each feed line crossing a respective one of the first through fourth slots; and a conductive ring that at least partially surrounds a periphery of the conductive patch and that encloses each of the first through fourth slots.

[0119] The conductive ring may, for example, be a continuous ring that completely surrounds the conductive patch when the radiating element is viewed in plan view, or may include a plurality of sections, where each section

encloses a respective one of the first through fourth slots.

[0120] The feed network may further include a first input, a first power divider that is coupled to the first input, a second input, and a second power divider that is coupled to the second input. The first and second feed lines may be coupled to respective first and second outputs of the first power divider, and the third and fourth feed lines may be coupled to respective first and second outputs of the second power divider. In some cases at least a portion of the conductive patch may be implemented on a first metal layer of a printed circuit board, the first through fourth feed lines may comprise metal traces on a second metal layer of the printed circuit board, and/or each of the first through fourth slots may extend to the periphery of the conductive patch. The second metal layer of the printed circuit board may further include a plurality of metal pads that are each electrically connected to the conductive patch via one or more plated through holes that extend between the first and second metal layers of the printed circuit board. The conductive patch may include a first portion that is implemented on a first metal layer of a printed circuit board and a second portion that is implemented on a different metal layer of the printed circuit board. In such embodiments, the different metal layer of the printed circuit board may be the second metal layer of the printed circuit board.

[0121] The conductive ring may be electrically floating or electrically connected to the conductive patch, and/or may be coplanar with at least a portion of the conductive patch.

[0122] In another example embodiment of the present invention, a radiating element for a base station antenna is provided that includes a printed circuit board that includes a conductive patch having first and second slots that each extend along a first axis and third and fourth slots that each extend along a second axis that is perpendicular to the first axis; a first coaxial cable and a second coaxial cable that each extend from a reflector of the base station antenna to the printed circuit board; and a conductive stub that physically and electrically connects an outer conductor of the first coaxial cable to an outer conductor of the second coaxial cable.

[0123] The printed circuit board may be mounted forwardly from the reflector at a distance that is greater than one-quarter of a wavelength corresponding to the center frequency of the operating frequency band of the radiating element. The conductive stub may be located at approximately one quarter of the wavelength corresponding to the center frequency of the operating frequency band of the radiating element from the printed circuit board. The conductive stub may be located closer to the reflector than it is to the printed circuit board.

[0124] The outer conductors of the first and second coaxial cables may be soldered to the printed circuit board. The radiating element may also include first and second conductive tubes that are positioned adjacent the first and second coaxial cables.

[0125] The printed circuit board may include a feed net-

work that has a first input that is electrically connected to an inner conductor of the first coaxial cable, a first power divider that is coupled to the first input, first and second transmission lines that extend from the first power divider to cross the respective first and second slots, a second input that is electrically connected to an inner conductor of the second coaxial cable, a second power divider that is coupled to the second input, and third and fourth transmission lines that extend from the second power divider to cross the respective third and fourth slots.

[0126] The conductive patch may be implemented at least partially on a first metal layer of the printed circuit board, the feed network may be implemented on a second metal layer of the printed circuit board, the second metal layer may further include a plurality of metal pads that are each electrically connected to the conductive patch, and each of the first through fourth slots may extend to a periphery of the conductive patch.

[0127] In still another example embodiment of the present invention, a radiating element for a base station antenna is provided that includes a printed circuit board that includes a conductive patch having first and second slots that each extend along a first axis and third and fourth slots that each extend along a second axis that is perpendicular to the first axis and a feed stalk that mounts the printed circuit board in front of a reflector of the base station antenna. A first metal layer of the printed circuit board includes a first portion of the conductive patch and a second metal layer of the printed circuit board includes a second portion of the conductive patch

[0128] The first portion of the conductive patch may be galvanically connected and/or capacitively coupled to the second portion of the conductive patch.

[0129] The printed circuit board may include a feed network that includes a first input, a first power divider that is coupled to the first input, and first and second transmission lines that extend from the first power divider to cross the respective first and second slots, and a second input, a second power divider that is coupled to the second input, and third and fourth transmission lines that extend from the second power divider to cross the respective third and fourth slots. The feed network may be implemented on the second metal layer of the printed circuit board.

[0130] The first portion of the conductive patch may be a central portion of the conductive patch and the second portion of the conductive patch be a first annular-shaped metal layer having an inner portion that overlaps the central portion of the conductive patch and an exterior portion that extends outwardly beyond the central portion of the conductive patch. The conductive patch may also include a third portion that comprises a second annular-shaped metal layer having an inner portion that overlaps the first annular-shaped metal layer of the second portion of the conductive patch and an exterior portion that extends outwardly beyond the first annular-shaped metal layer of the second portion of the conductive patch. The third por-

tion of the conductive patch may be implemented in the first metal layer.

[0131] Each of the first through fourth slots may extend to a periphery of the conductive patch.

[0132] The first portion of the conductive patch may include a plurality of arms extending outwardly from a central region, where each arm includes an opening that is free of metallization that extends inwardly from a distal portion of the respective arm. The openings may be generally T-shaped openings. The second metal layer may overlap each opening.

[0133] The respective openings may divide each arm into first and second legs, and a first leg of a first of the arms and a second leg of an adjacent one of the arms may together form a dipole radiator.

[0134] In still another example embodiment of the present invention, a radiating element for a base station antenna is provided that includes a conductive patch having first through fourth slots that each extend along a first axis and fifth through eighth slots that each extend along a second axis that is perpendicular to the first axis, each of the first through fourth slots extending to a periphery of the conductive patch, the first through eighth slots dividing the conductive patch into four conductive arms and a first trace that extends from the first conductive arm to the second conductive arm to separate the first slot from the second slot.

[0135] The radiating element may further include a second trace that extends from the second conductive arm to the third conductive arm to separate the fifth slot from the sixth slot, a third trace that extends from the third conductive arm to the fourth conductive arm to separate the third slot from the fourth slot, a fourth trace that extends from the fourth conductive arm to the first conductive arm to separate the seventh slot from the eighth slot and/or a feed stalk that mounts a printed circuit board in front of a reflector of the base station antenna.

[0136] In another example embodiment of the present invention, a method of suppressing a common mode resonance in a base station antenna is provided. The base station antenna may have a reflector, an array of first radiating elements that are configured to operate in a first operating frequency band and an array of second radiating elements that are configured to operate in a second operating frequency band, where each second radiating element includes a radiator unit that is positioned forwardly of the reflector and at least one coaxial feed cable that connects to the radiator unit. Pursuant to this method, an outer conductor of a first of the coaxial feed cables that feeds a first of the second radiating elements is electrically connected to the reflector at a grounding position that is selected so that the physical distance of the RF transmission path that extends between the grounding position and the radiator unit of the first of the second radiating elements is a distance that is not resonant at any frequency in the first operating frequency band.

[0137] The grounding position may be a position where an outer conductor of the first of the coaxial feed cables

is galvanically connected to a rear surface of the reflector. The first of the coaxial feed cables may be galvanically connected to a rear surface of the reflector by exposing a portion of the outer conductor and soldering the exposed portion of the outer conductor to the reflector.

[0138] The first of the coaxial feed cables may extend between the radiator unit and a printed circuit board, and the printed circuit board may include a grounding tab where a ground conductor of the printed circuit board is coupled to the reflector. The physical distance of the RF transmission path that extends between the grounding position and the radiator unit of the first of the second radiating elements may be the sum of the length of the first of the coaxial feed cables and a distance between the location where the first of the coaxial feed cables connects to the printed circuit board and the grounding tab, and may not be a multiple of a quarter wavelength of any frequency in the first operating frequency band.

[0139] Embodiments of the present invention have been described above with reference to the accompanying drawings, in which embodiments of the invention are shown. This invention may, however, be embodied in many different forms and should not be construed as limited to the embodiments set forth herein. Rather, these embodiments are provided so that this disclosure will be thorough and complete, and will fully convey the scope of the invention to those skilled in the art. Like numbers refer to like elements throughout.

[0140] It will be understood that, although the terms first, second, etc. may be used herein to describe various elements, these elements should not be limited by these terms. These terms are only used to distinguish one element from another. For example, a first element could be termed a second element, and, similarly, a second element could be termed a first element, without departing from the scope of the present invention. As used herein, the term "and/or" includes any and all combinations of one or more of the associated listed items.

[0141] It will be understood that when an element is referred to as being "on" another element, it can be directly on the other element or intervening elements may also be present. In contrast, when an element is referred to as being "directly on" another element, there are no intervening elements present. It will also be understood that when an element is referred to as being "connected" or "coupled" to another element, it can be directly connected or coupled to the other element or intervening elements may be present. In contrast, when an element is referred to as being "directly connected" or "directly coupled" to another element, there are no intervening elements present. Other words used to describe the relationship between elements should be interpreted in a like fashion (*i.e.*, "between" versus "directly between", "adjacent" versus "directly adjacent", etc.).

[0142] Relative terms such as "below" or "above" or "upper" or "lower" or "horizontal" or "vertical" may be used herein to describe a relationship of one element, layer or region to another element, layer or region as illustrated

in the figures. It will be understood that these terms are intended to encompass different orientations of the device in addition to the orientation depicted in the figures.

[0143] The terminology used herein is for the purpose of describing particular embodiments only and is not intended to be limiting of the invention. As used herein, the singular forms "a", "an" and "the" are intended to include the plural forms as well, unless the context clearly indicates otherwise. It will be further understood that the terms "comprises" "comprising," "includes" and/or "including" when used herein, specify the presence of stated features, operations, elements, and/or components, but do not preclude the presence or addition of one or more other features, operations, elements, components, and/or groups thereof.

[0144] Aspects and elements of all of the embodiments disclosed above can be combined in any way and/or combination with aspects or elements of other embodiments to provide a plurality of additional embodiments.

Claims

1. A radiating element, comprising:
 - a conductive patch having first and second slots that each extend along a first axis and third and fourth slots that each extend along a second axis that is perpendicular to the first axis;
 - a feed network that includes first through fourth feed lines, each feed line crossing a respective one of the first through fourth slots, wherein the first and second feed lines are forward of a first major surface of the conductive patch and the third and fourth feed lines are rearward of a second major surface of the conductive patch.
2. The radiating element of Claim 1, wherein the conductive patch is formed of sheet metal.
3. The radiating element of Claims 1 or 2, further comprising a stalk, wherein the stalk includes first and second air microstrip transmission lines.
4. The radiating element of Claim 3, wherein a signal trace of the first air microstrip transmission line and the first and second feed lines are formed as a first monolithic feed structure, and a signal trace of the second air microstrip transmission line and the third and fourth feed lines are formed as a second monolithic feed structure.
5. The radiating element of Claim 4, wherein the first monolithic feed structure extends through an opening in the conductive patch.
6. The radiating element of Claims 4 or 5, wherein the second monolithic feed structure does not extend through any opening in the conductive patch.
7. The radiating element of any of Claims 1-6, wherein outer edges of the conductive patch are bent at an angle of at least 30° with respect to an inner portion of the conductive patch.
8. The radiating element of any of Claims 1-7, wherein each of the first through fourth slots extend to the periphery of the conductive patch.
9. The radiating element of any of Claims 1-8, wherein the conductive patch includes a plurality of arms extending outwardly from a central region, wherein each arm includes an opening that extends to a distal portion of the respective arm.
10. The radiating element of Claim 9, wherein each opening is a generally T-shaped opening.
11. The radiating element of Claims 9 or 10, wherein an outer portion of each arm is bent at an angle of at least 45° with respect to an inner portion of the arm.
12. The radiating element of Claim 11, wherein metal layers overlap the respective openings in the arms.
13. The radiating element of Claim 12, wherein each metal layer is capacitively coupled with the respective arm.
14. The radiating element of any of Claims 1-13, wherein each of the first through fourth slots includes a first portion that extends in a plane defined by an inner portion of the conductive patch, and a second portion that extends at an oblique angle with respect to the first portion.
15. The radiating element of any of Claims 1-14, wherein the feed network further includes a first input, a first power divider that is coupled to the first input, a second input, and a second power divider that is coupled to the second input, and wherein the first and second feed lines are coupled to respective first and second outputs of the first power divider, and the third and fourth feed lines are coupled to respective first and second outputs of the second power divider.

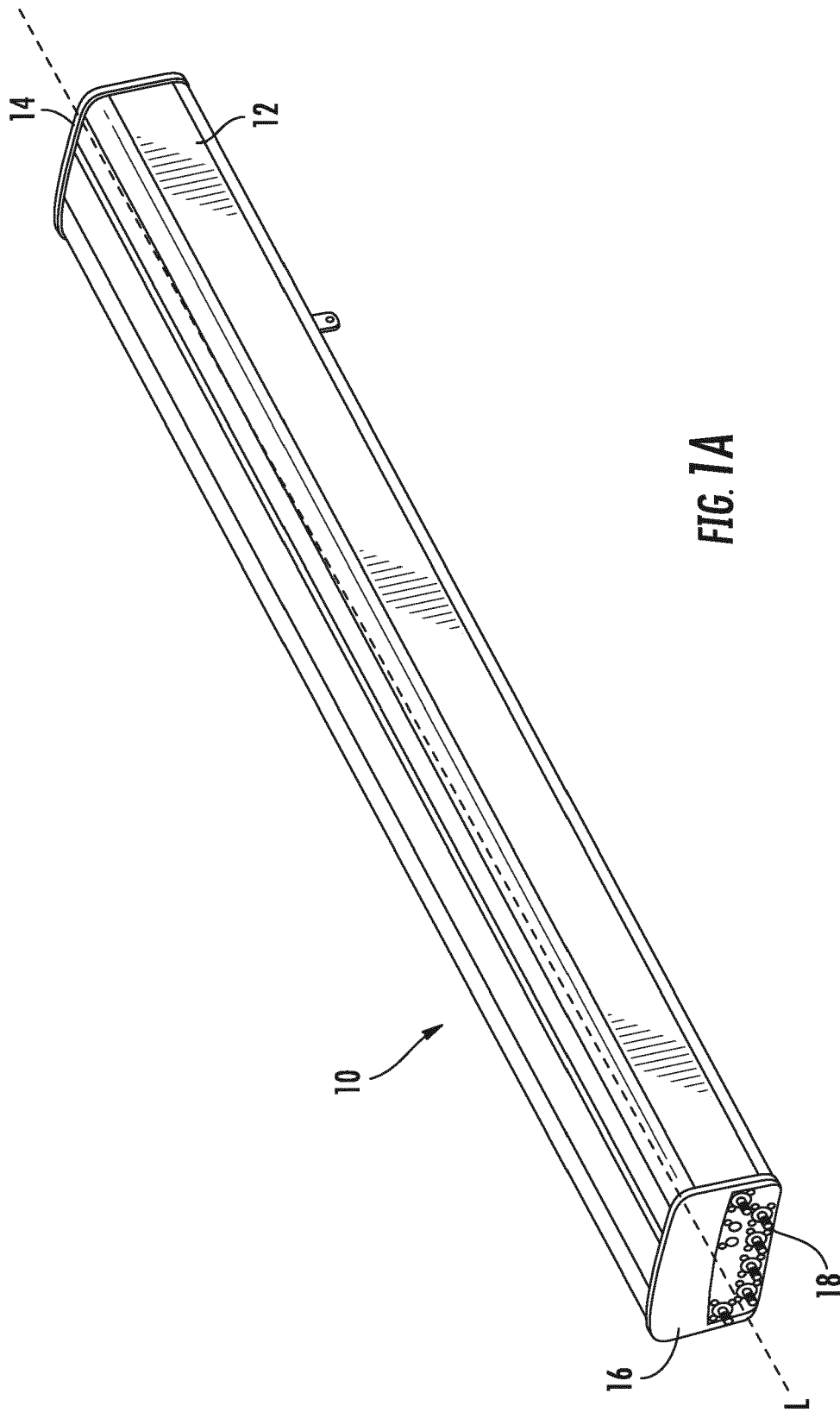

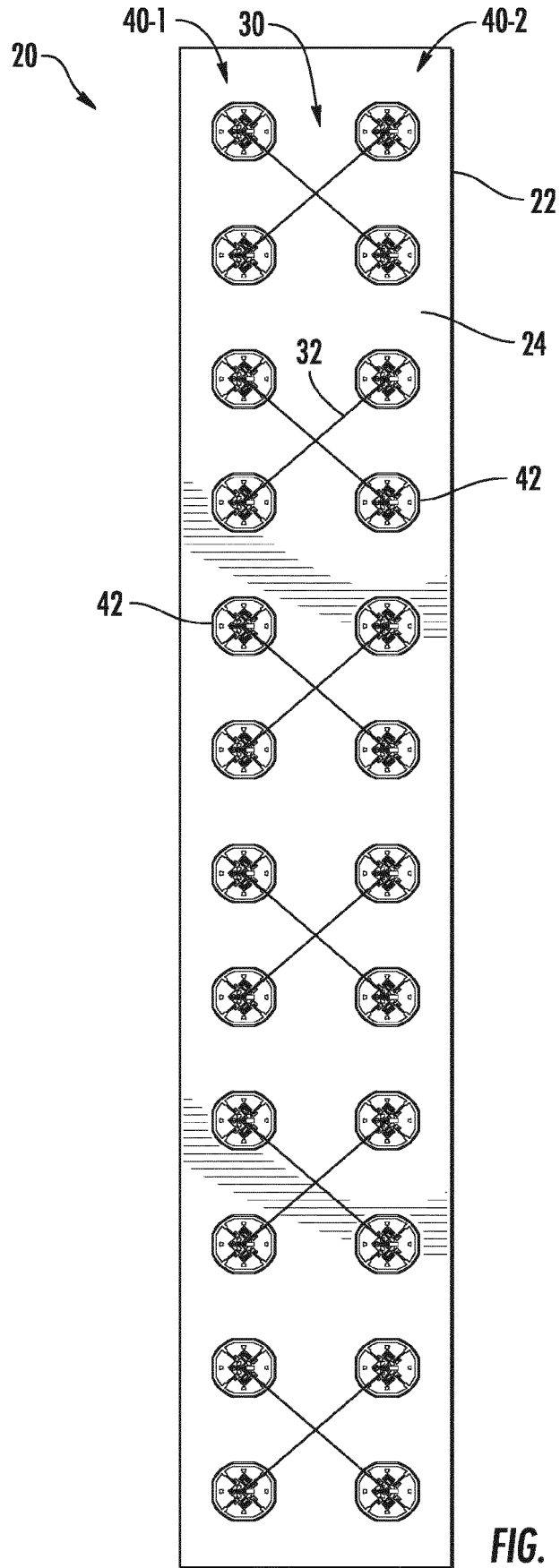

FIG. 1B

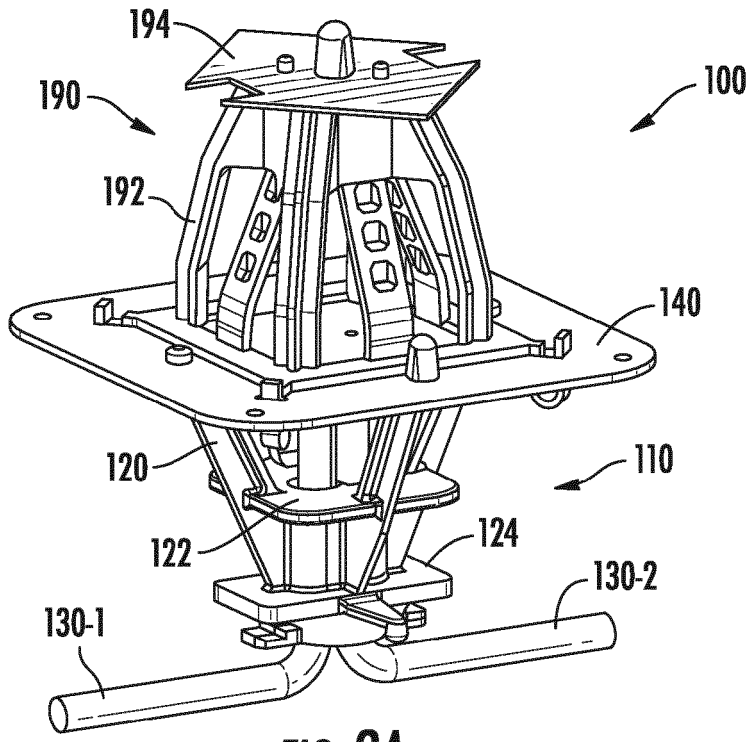

FIG. 2A

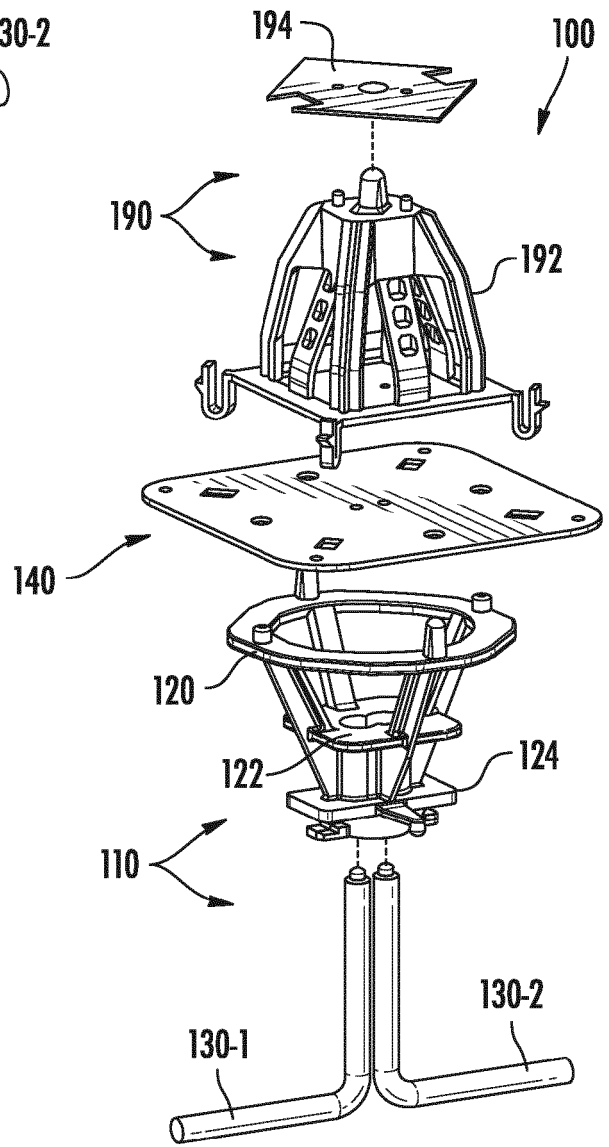

FIG. 2B

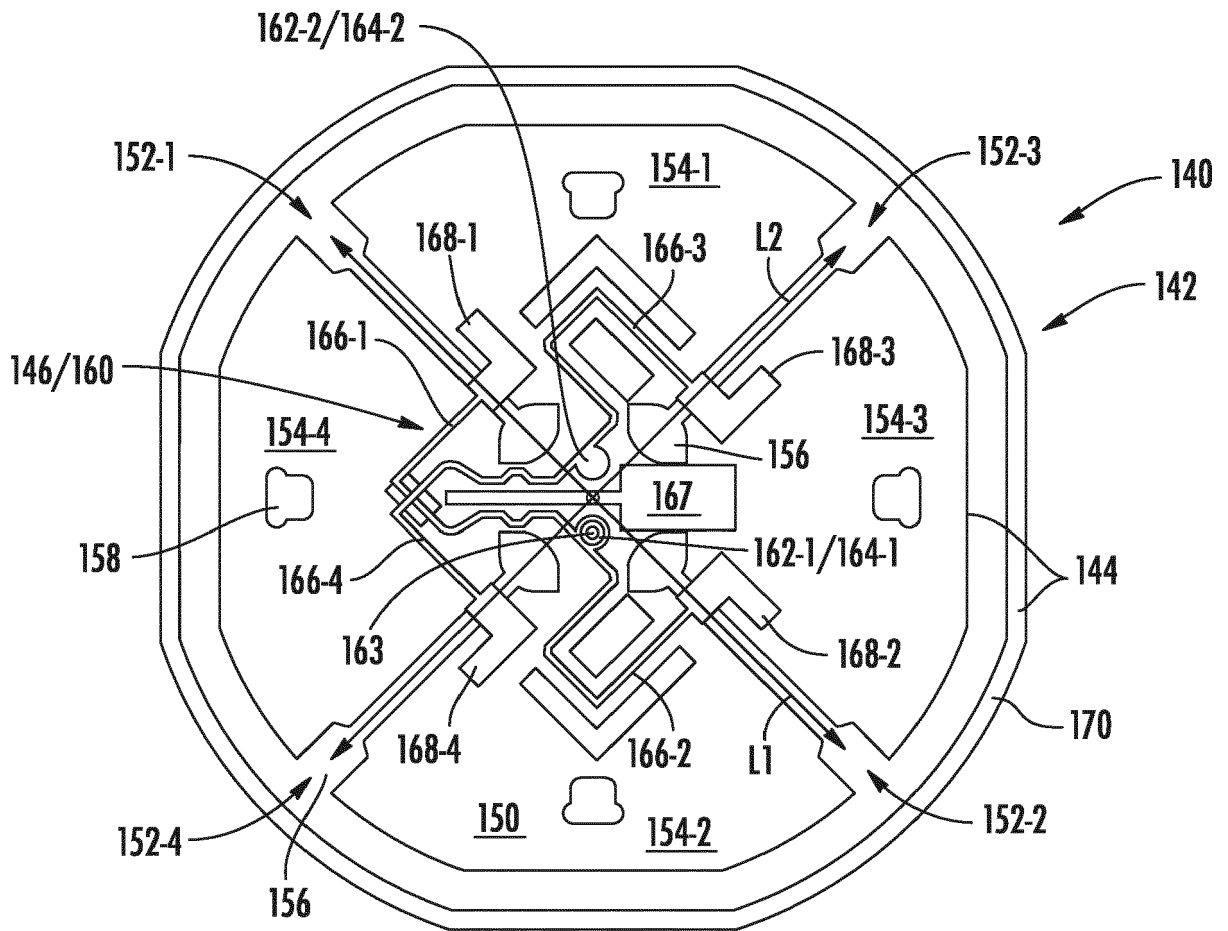

FIG. 3A

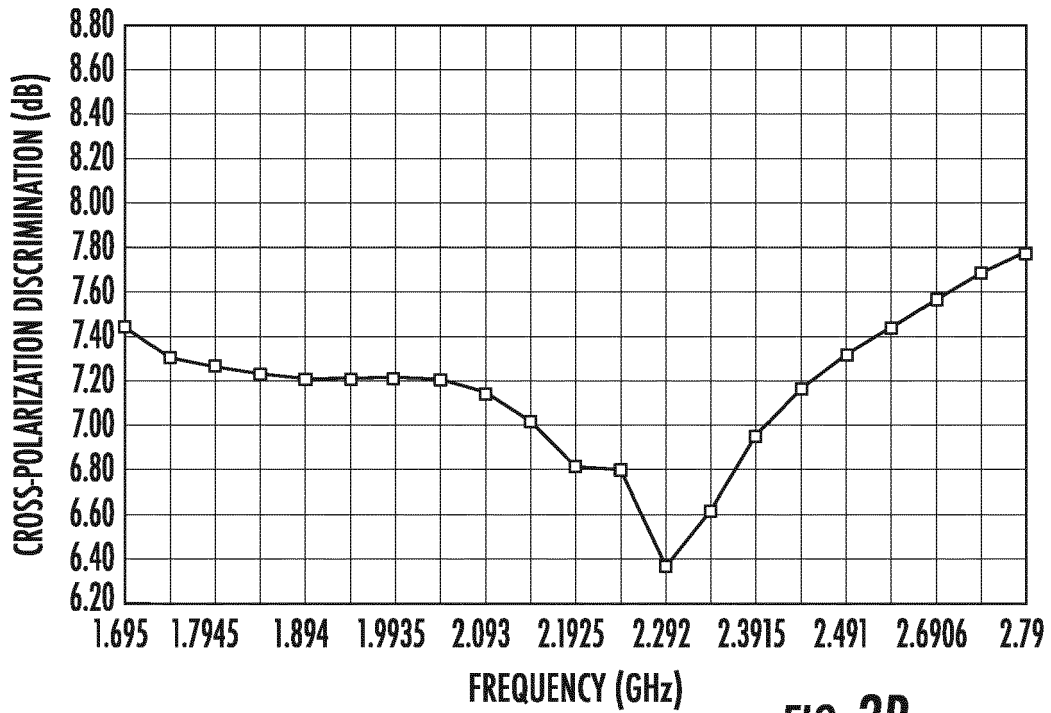

FIG. 3B

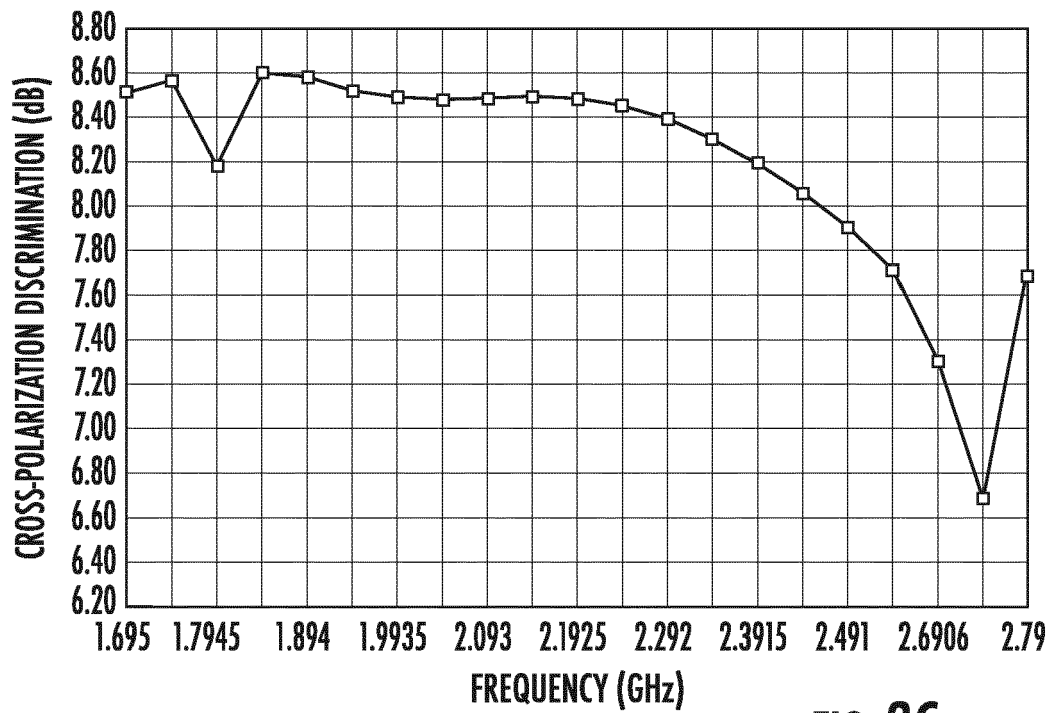

FIG. 3C

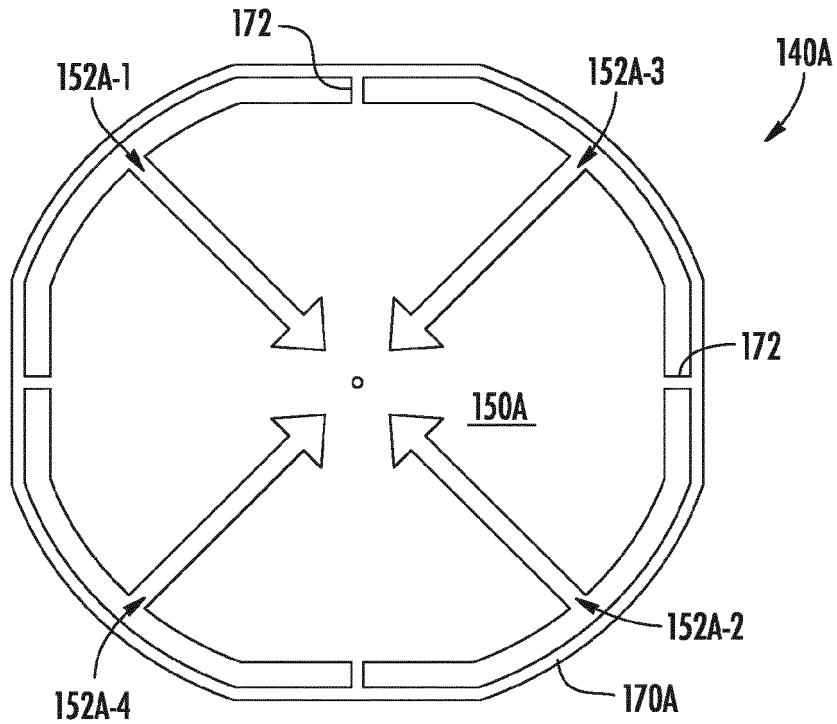

FIG. 4A

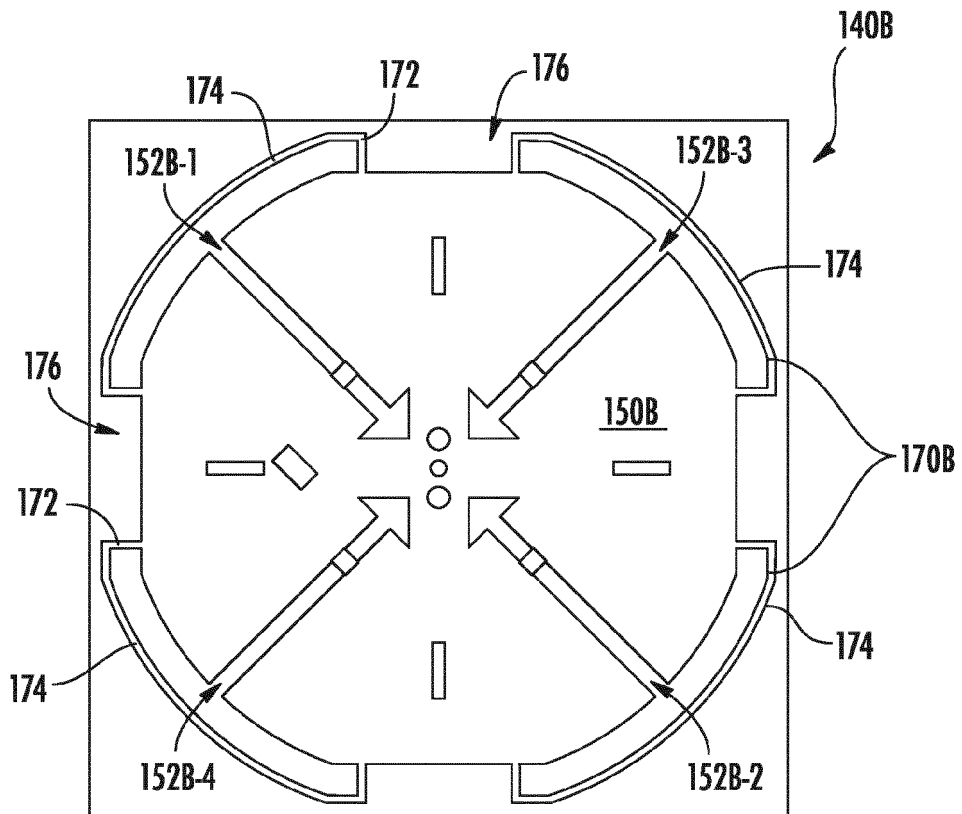

FIG. 4B

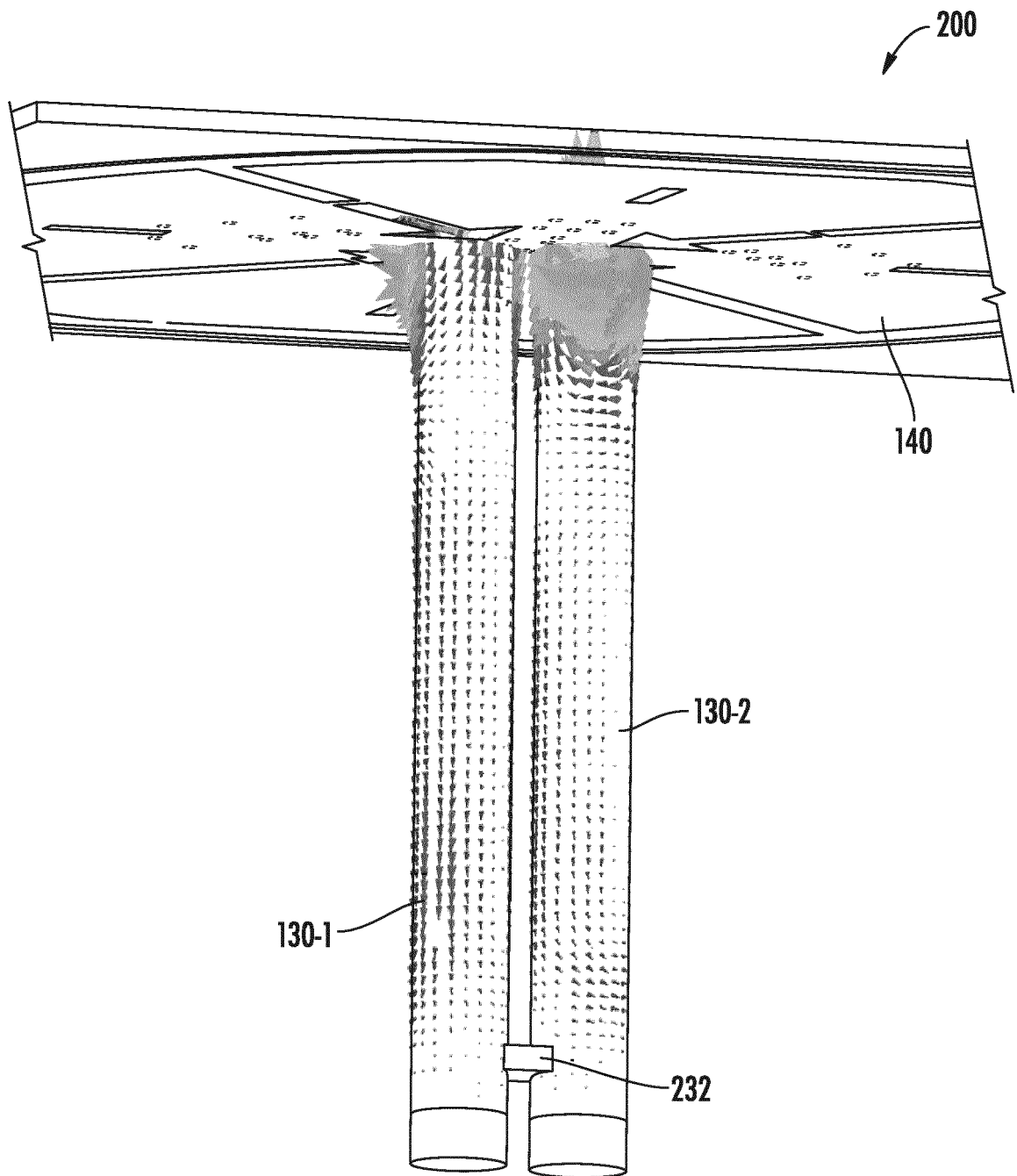

FIG. 5A

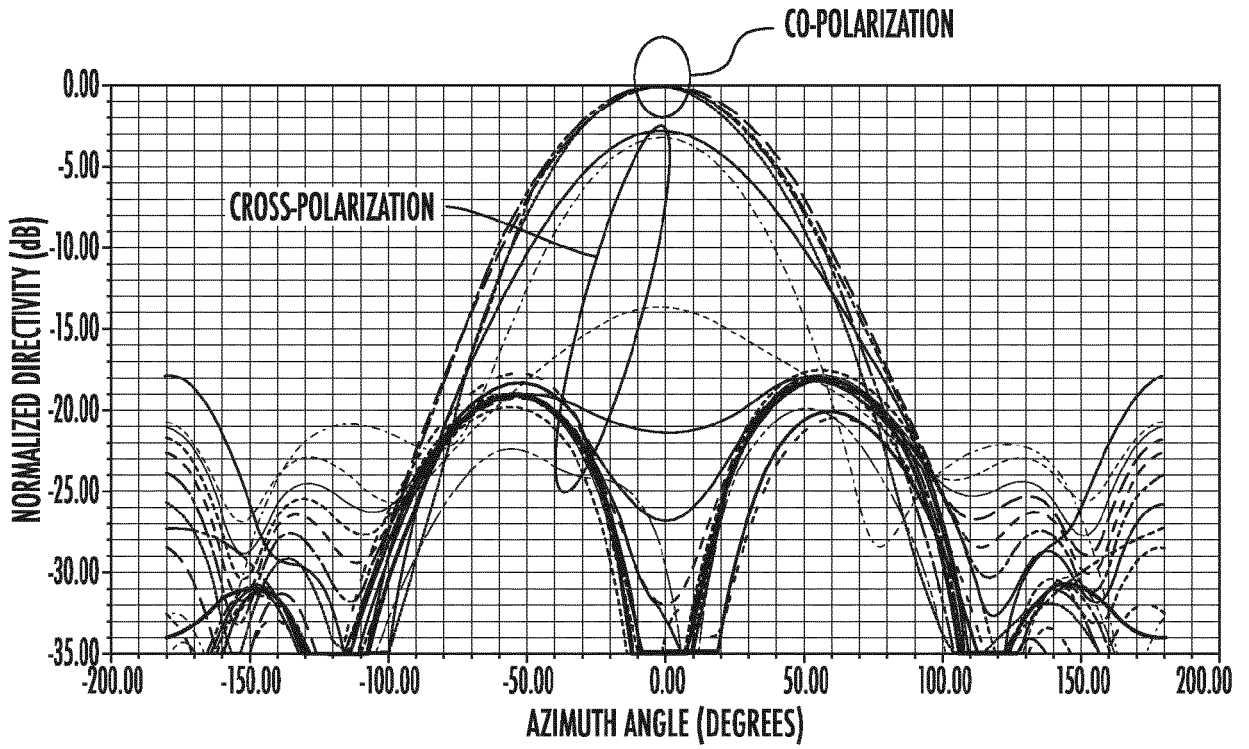

FIG. 5B

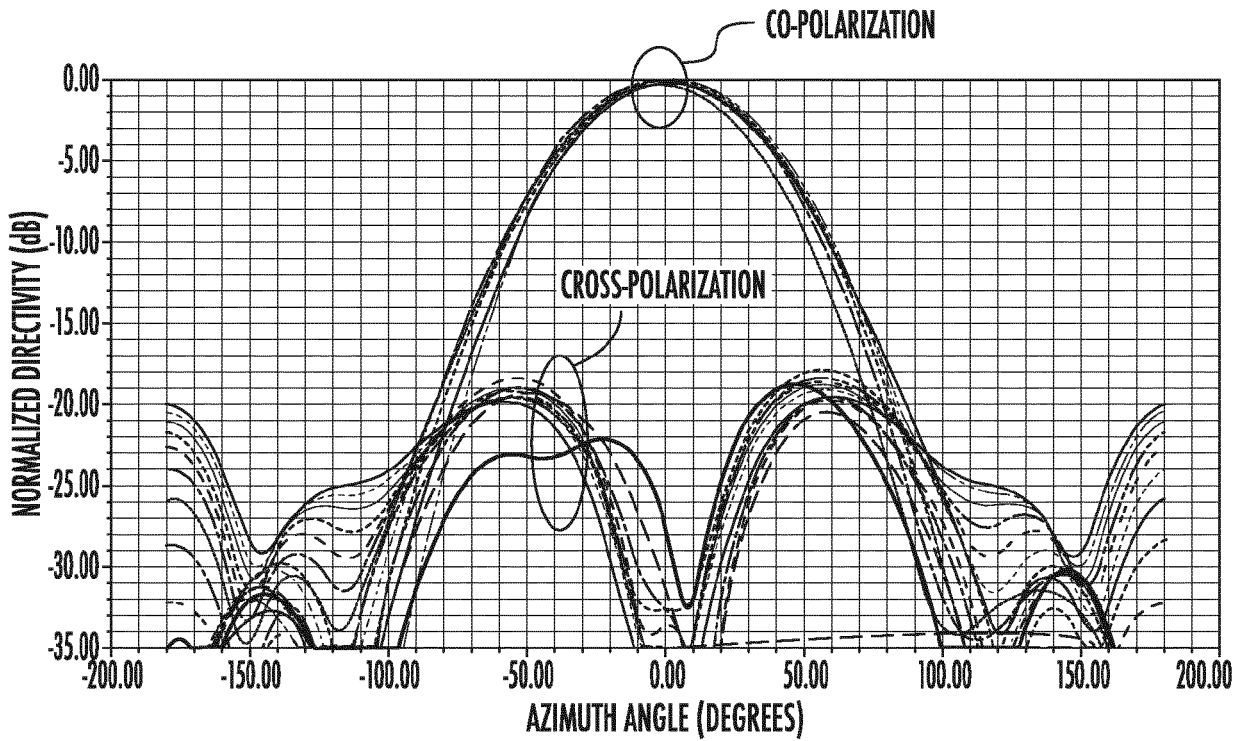

FIG. 5C

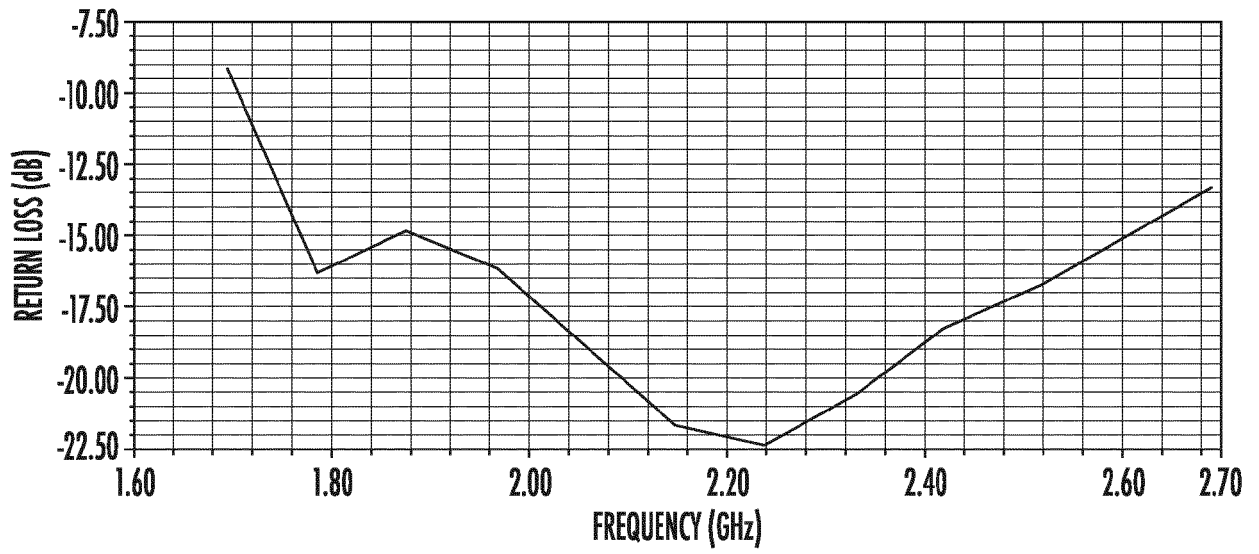

FIG. 5D

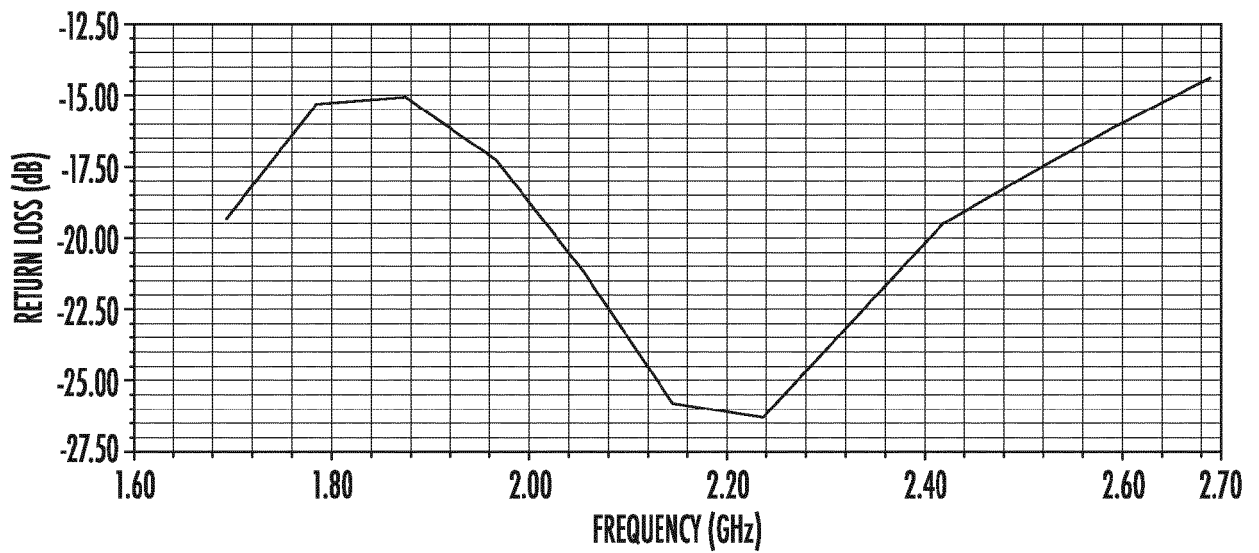

FIG. 5E

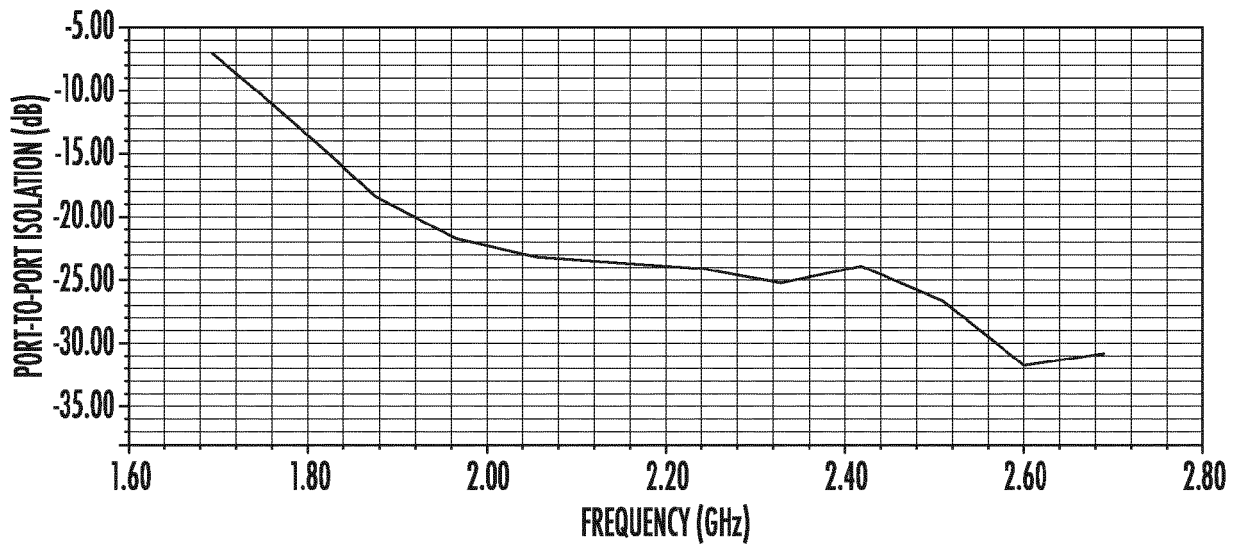

FIG. 5F

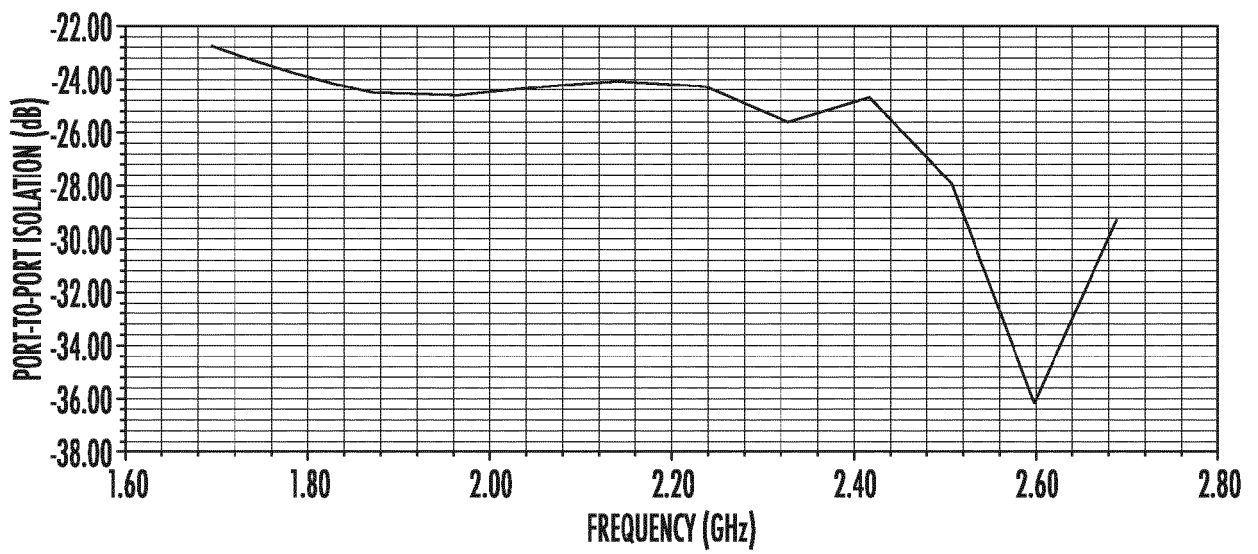
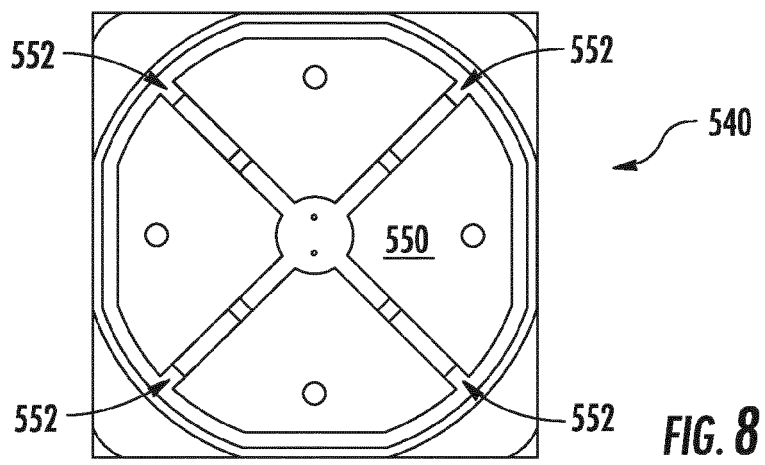
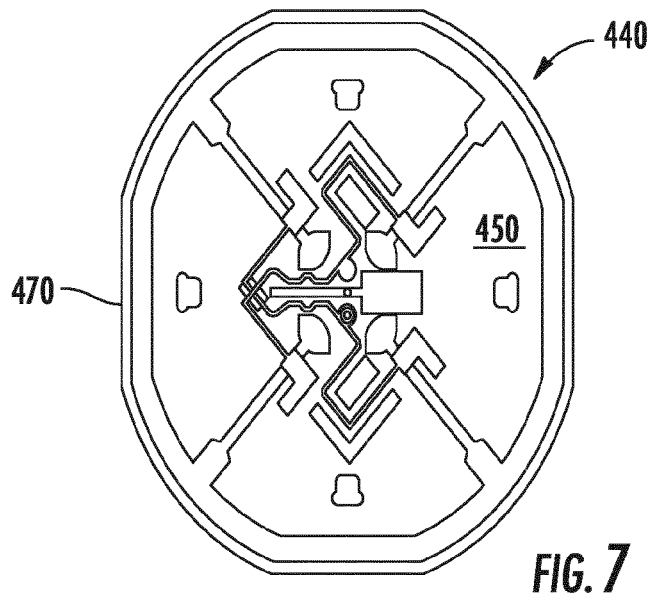
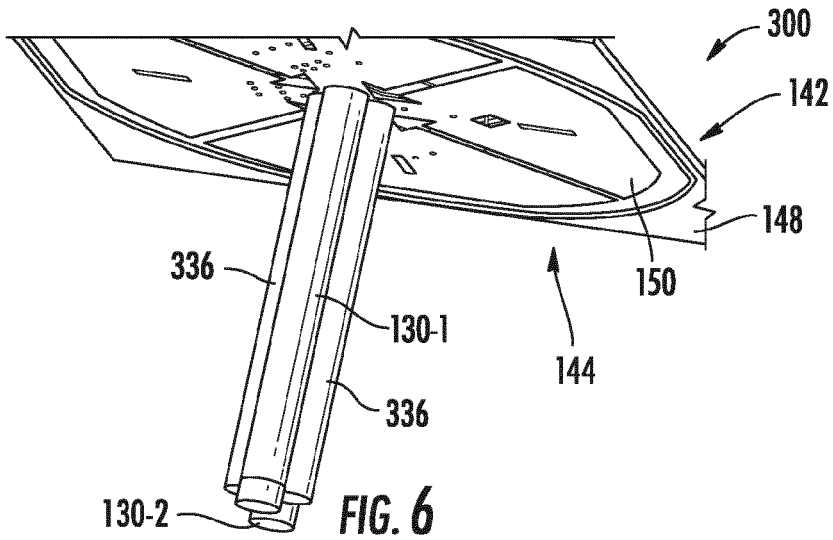

FIG. 5G



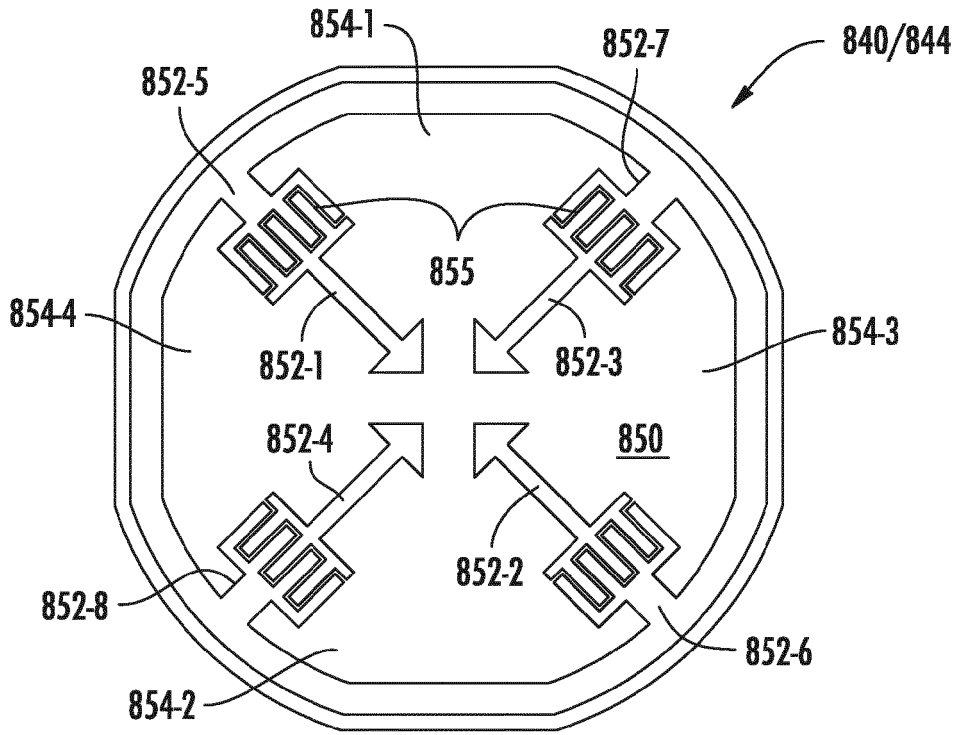

FIG. 11A

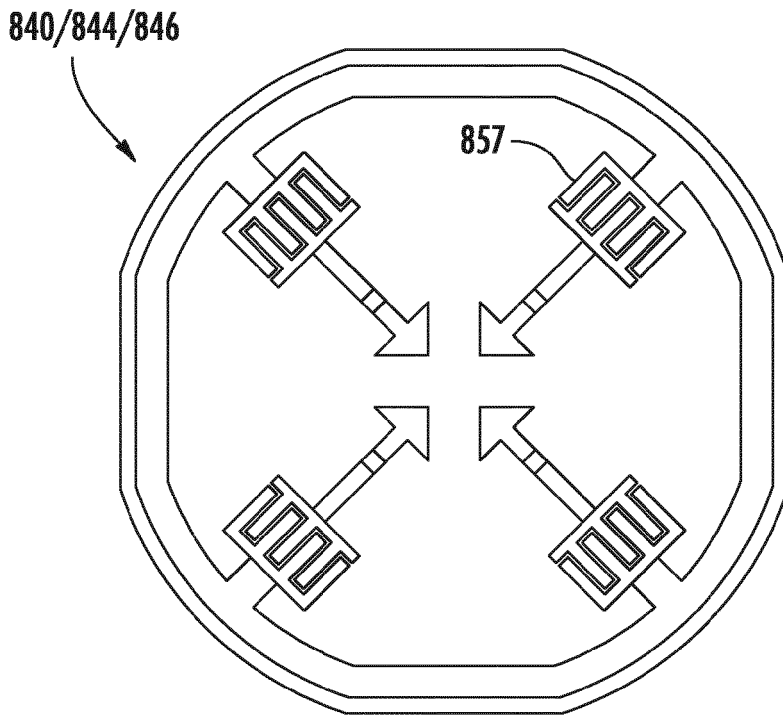

FIG. 11B

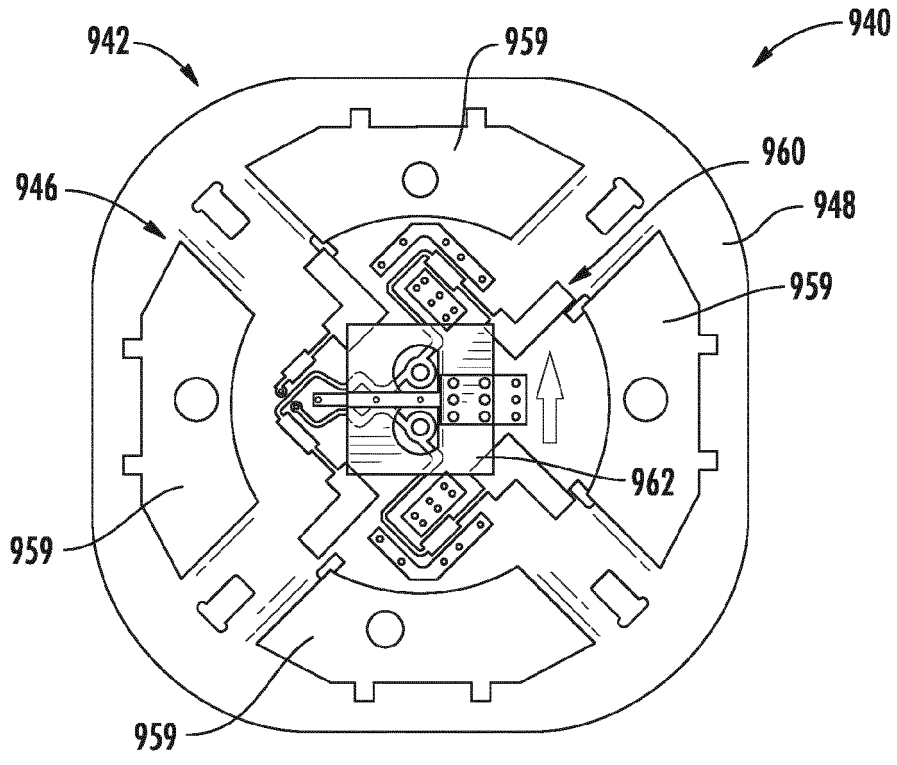

FIG. 12A

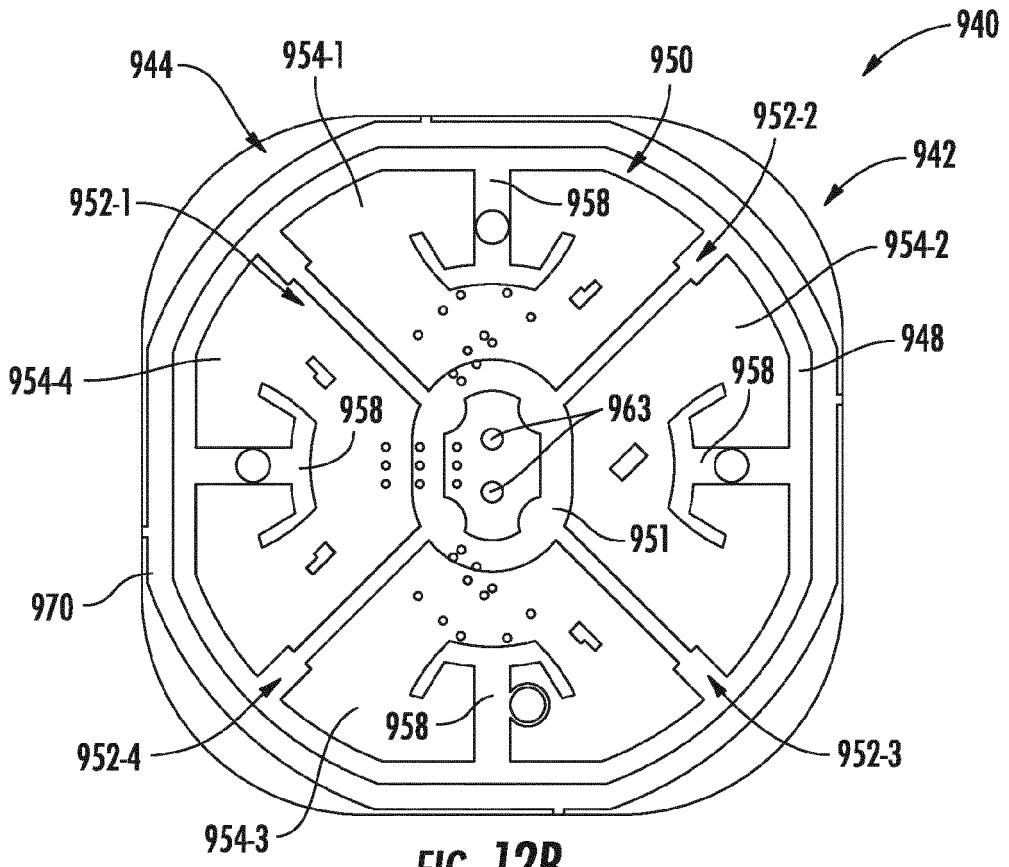

FIG. 12B

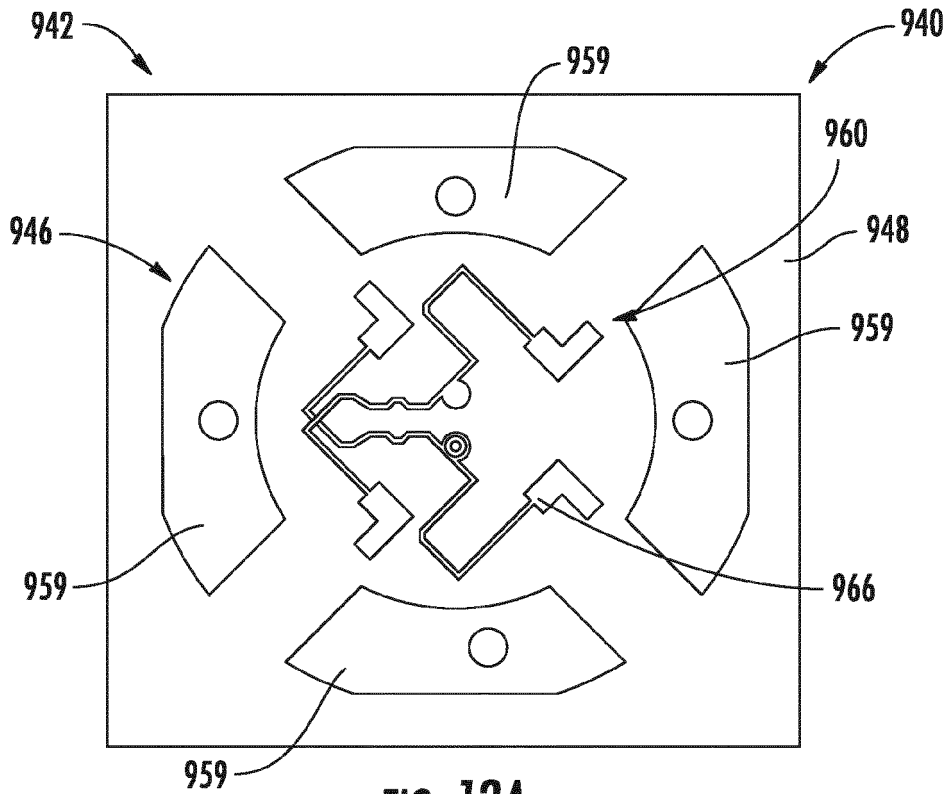

FIG. 13A

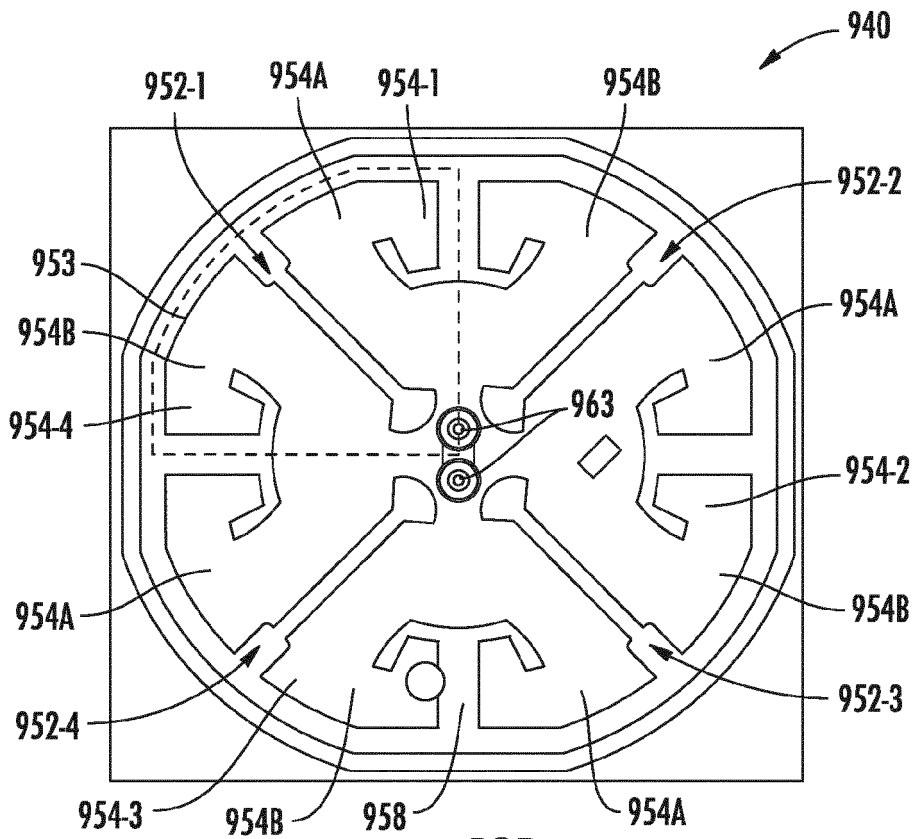

FIG. 13B

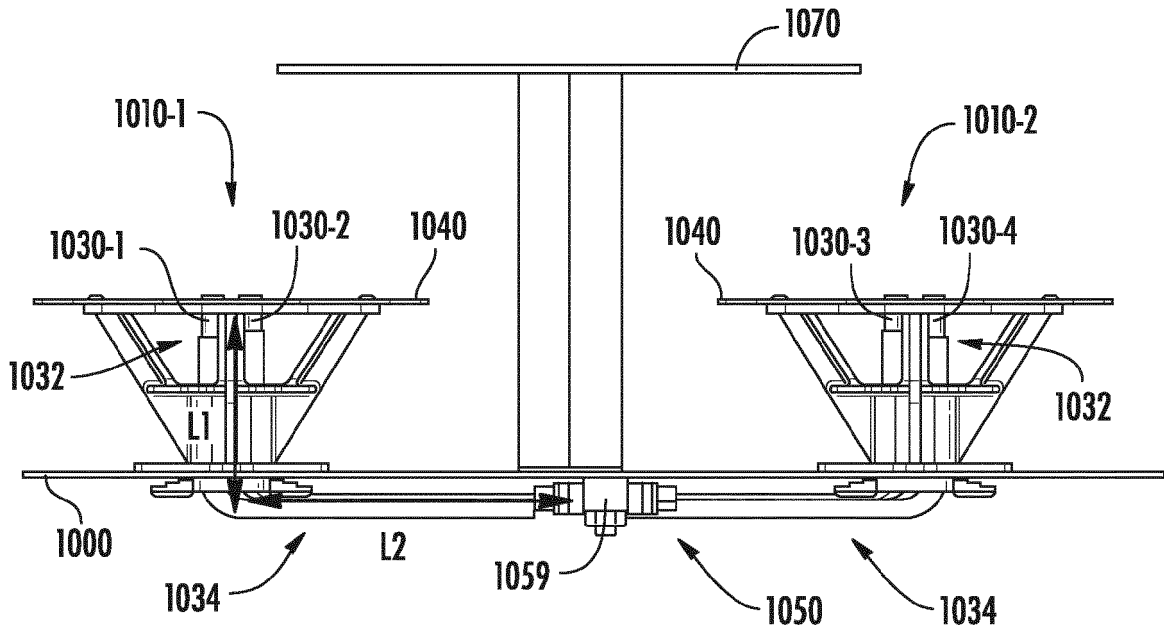

FIG. 14A

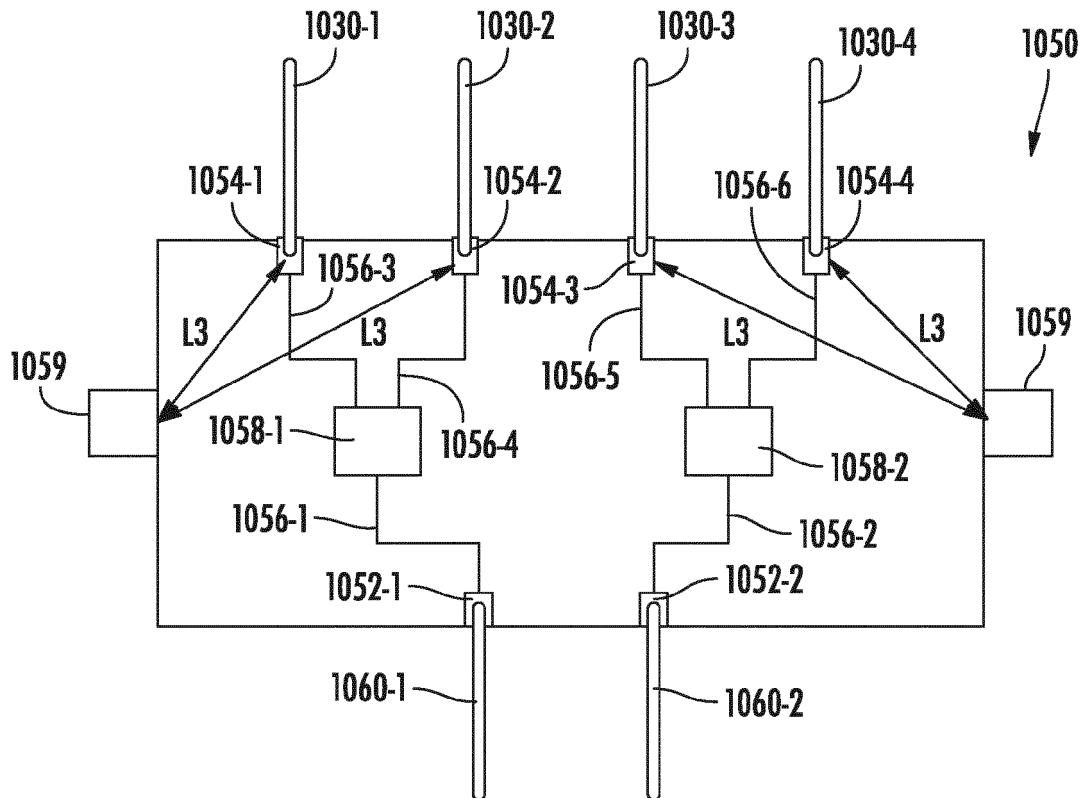

FIG. 14B

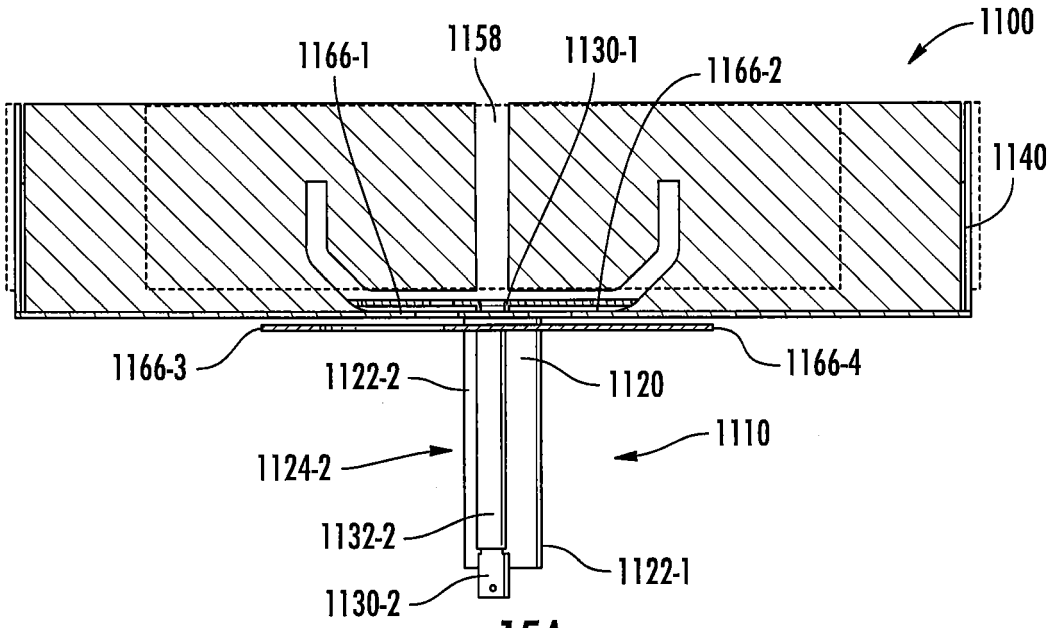

FIG. 15A

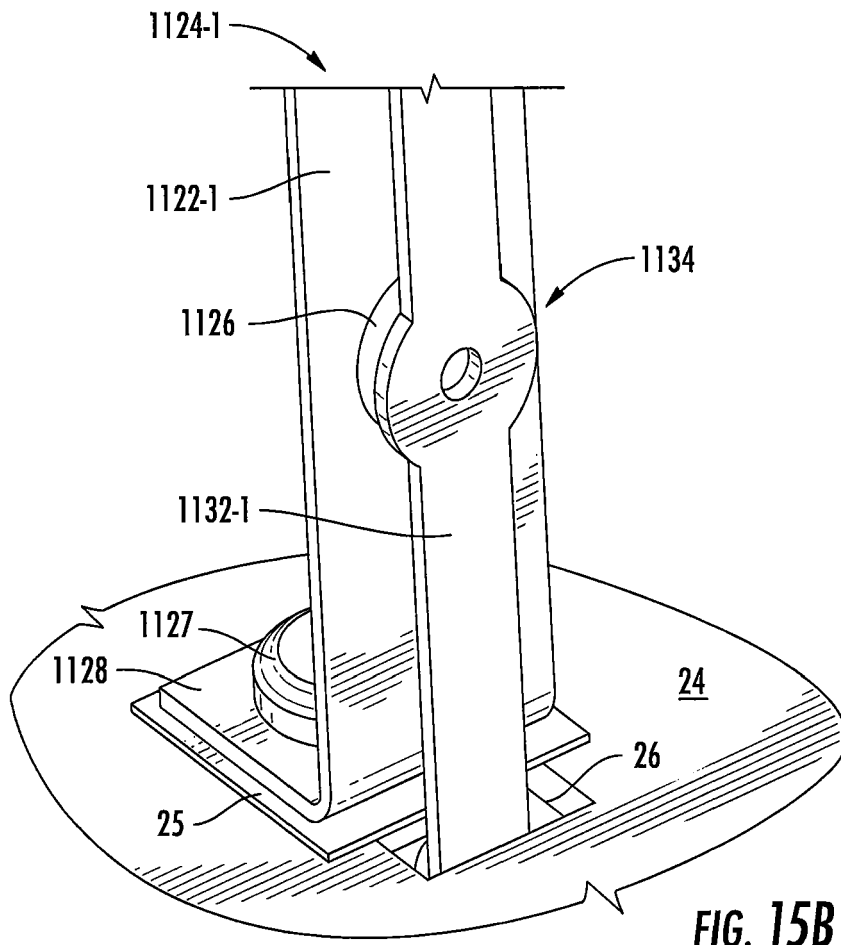
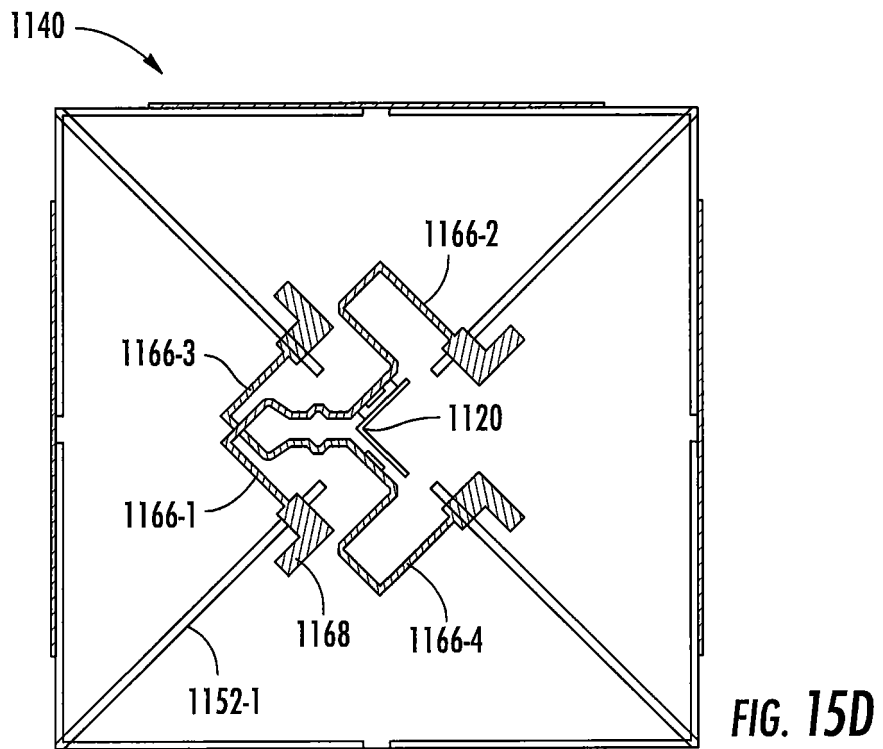
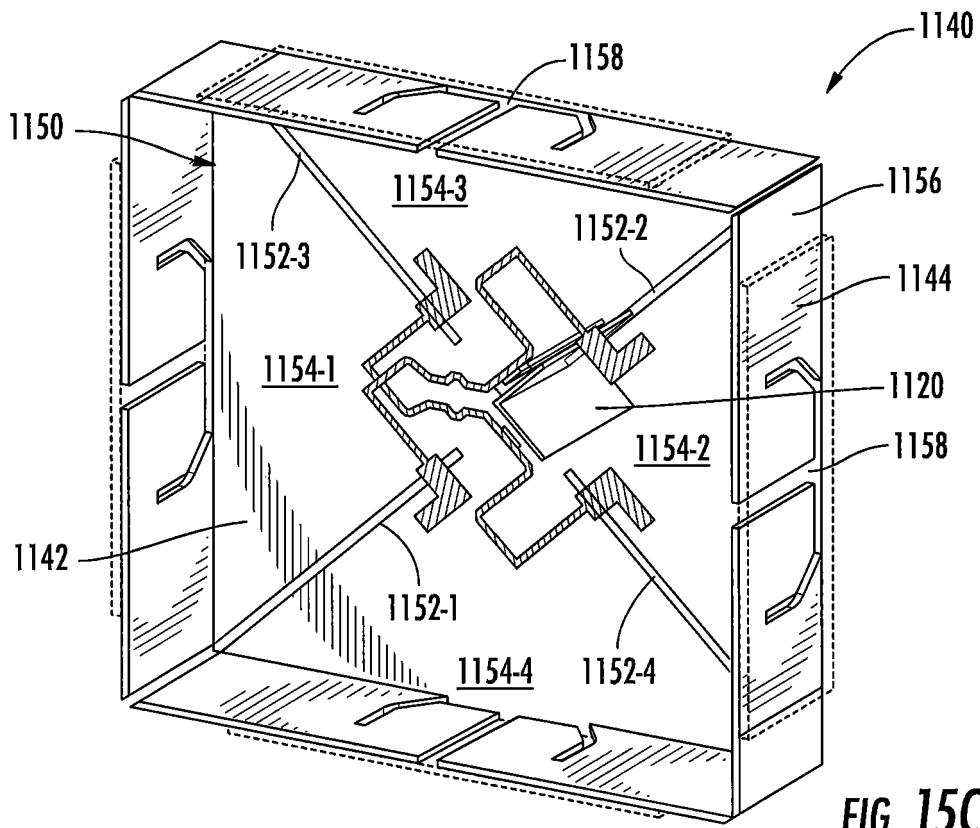

FIG. 15B



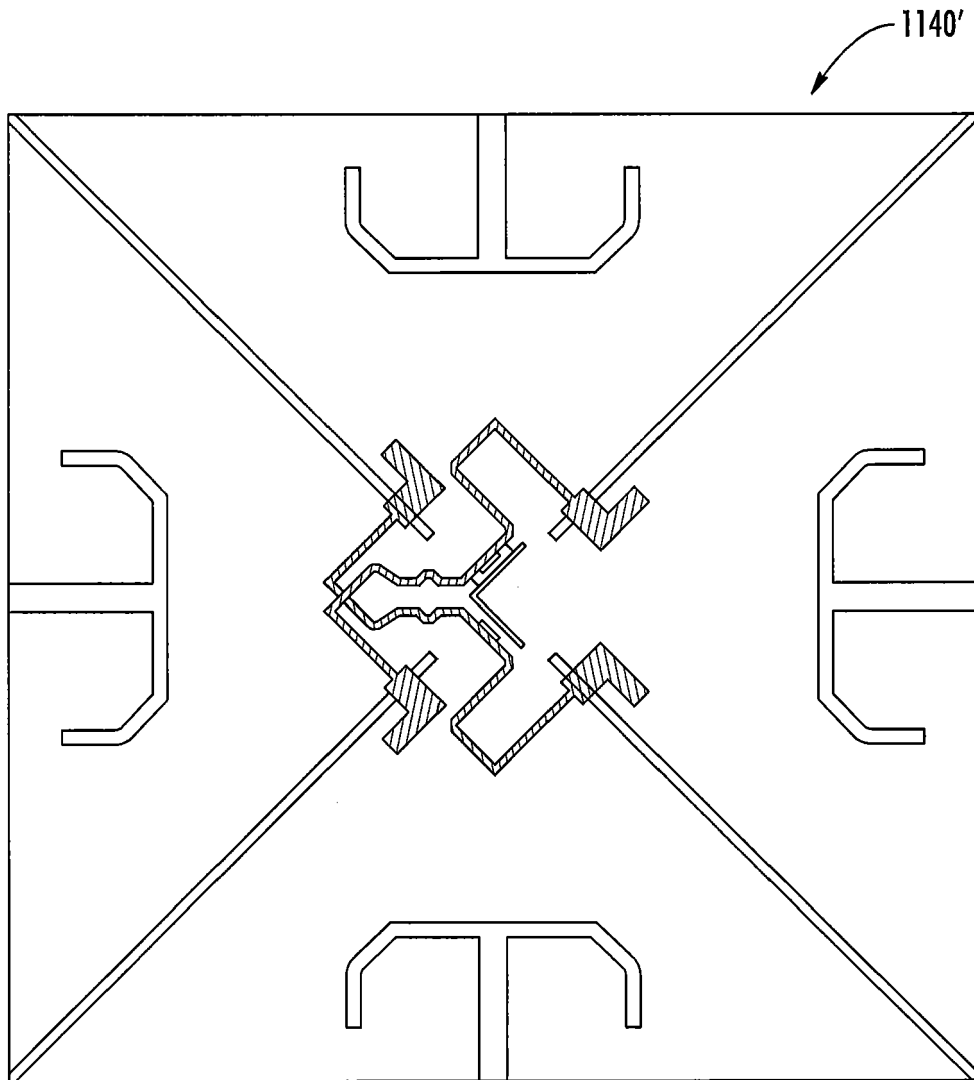

FIG. 15E

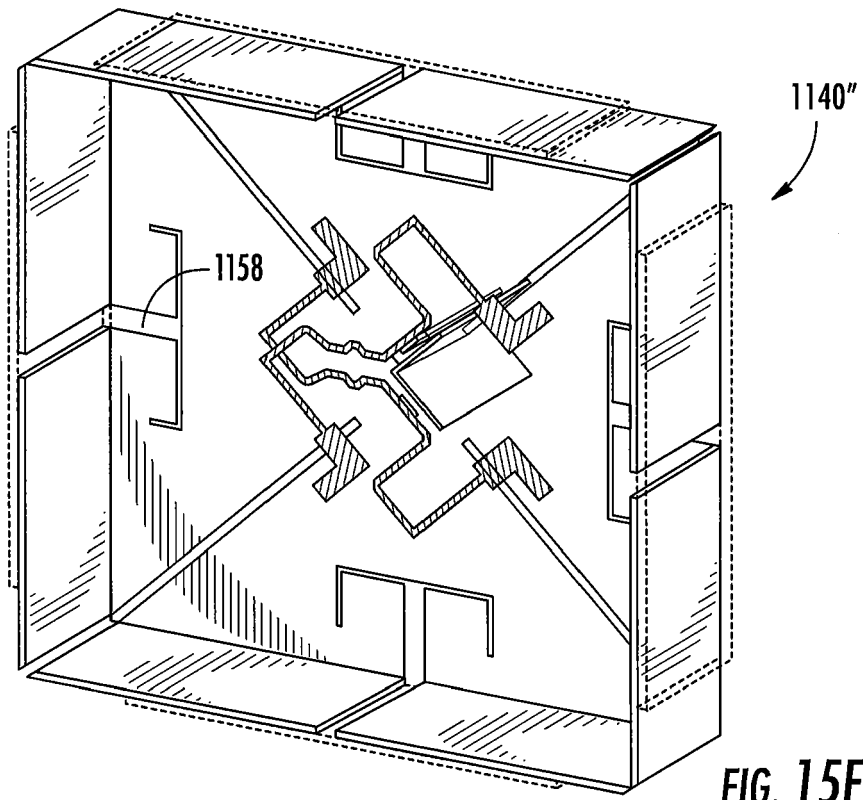

FIG. 15F

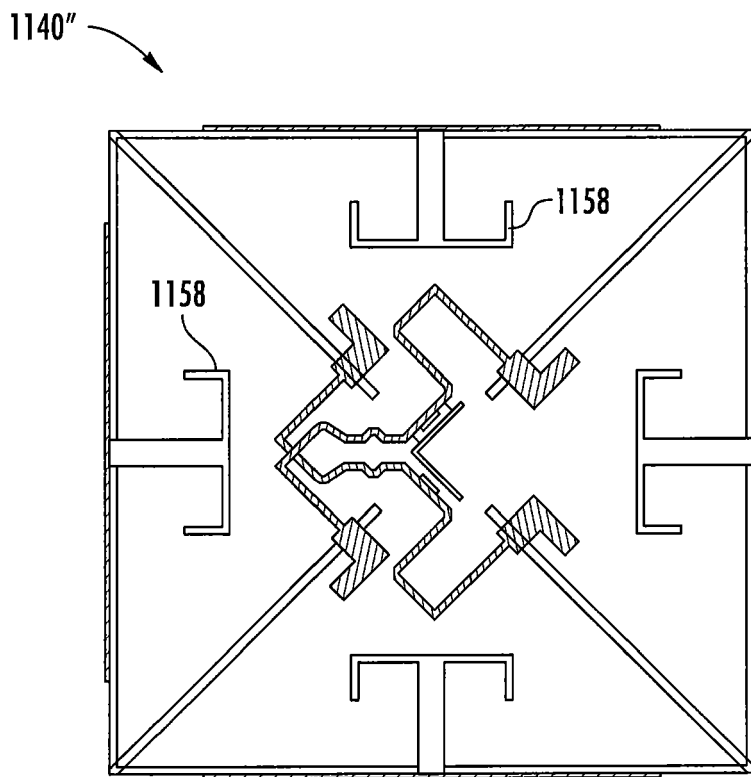

FIG. 15G



EUROPEAN SEARCH REPORT

Application Number
EP 21 15 2353

5

10

15

20

25

30

35

40

45

50

55

DOCUMENTS CONSIDERED TO BE RELEVANT			
Category	Citation of document with indication, where appropriate, of relevant passages	Relevant to claim	CLASSIFICATION OF THE APPLICATION (IPC)
X Y A	US 2002/163477 A1 (ERIKSSON STEFAN G [SE]) 7 November 2002 (2002-11-07) * paragraphs [0029], [0037] - paragraph [0041]; figures 1a, 2a, 4, 5 *	1-6, 8-10,15 11,12 13	INV. H01Q1/24 H01Q5/42 H01Q21/26 H01Q9/04
X,D	US 2007/241983 A1 (CAO HUY T [US] ET AL) 18 October 2007 (2007-10-18) * paragraph [0020] - paragraph [0034]; figures 1, 4 *	1-6, 8-10,15	
X	WO 2018/205277 A1 (TONGYU COMMUNICATION INC [CN]) 15 November 2018 (2018-11-15) * paragraph [0048] - paragraph [0065]; figures 1, 2, 4 *	1,2, 8-10,15	
X A	US 2019/252777 A1 (LINDMARK BJORN [SE]) 15 August 2019 (2019-08-15) * paragraphs [0025] - [0027], [0073] - paragraph [0077]; figures 4-6 *	1,2,7,8, 10,14,15 13	
X Y A	WO 2017/178037 A1 (HUAWEI TECH CO LTD [CN]; SEGADOR ALVAREZ JUAN [DE] ET AL.) 19 October 2017 (2017-10-19) * page 8 - page 11; figures 1, 4-6 *	1-8,14, 15 11,12 13	TECHNICAL FIELDS SEARCHED (IPC) H01Q
The present search report has been drawn up for all claims			
Place of search The Hague		Date of completion of the search 26 May 2021	Examiner Hueso González, J
CATEGORY OF CITED DOCUMENTS X : particularly relevant if taken alone Y : particularly relevant if combined with another document of the same category A : technological background O : non-written disclosure P : intermediate document		T : theory or principle underlying the invention E : earlier patent document, but published on, or after the filing date D : document cited in the application L : document cited for other reasons & : member of the same patent family, corresponding document	

EPO FORM 1503 03.82 (P04C01)

ANNEX TO THE EUROPEAN SEARCH REPORT
ON EUROPEAN PATENT APPLICATION NO.

EP 21 15 2353

5

This annex lists the patent family members relating to the patent documents cited in the above-mentioned European search report. The members are as contained in the European Patent Office EDP file on
The European Patent Office is in no way liable for these particulars which are merely given for the purpose of information.

26-05-2021

10

15

20

25

30

35

40

45

50

55

Patent document cited in search report	Publication date	Patent family member(s)	Publication date
US 2002163477 A1	07-11-2002	NONE	
US 2007241983 A1	18-10-2007	AU 2007238150 A1 CN 101427423 A CN 104821439 A EP 2008341 A2 JP 2009534942 A US 2007241983 A1 WO 2007121204 A2	25-10-2007 06-05-2009 05-08-2015 31-12-2008 24-09-2009 18-10-2007 25-10-2007
WO 2018205277 A1	15-11-2018	CN 108063318 A EP 3622578 A1 US 2020044327 A1 WO 2018205277 A1	22-05-2018 18-03-2020 06-02-2020 15-11-2018
US 2019252777 A1	15-08-2019	CN 109891672 A EP 3533109 A1 US 2019252777 A1 WO 2018077952 A1	14-06-2019 04-09-2019 15-08-2019 03-05-2018
WO 2017178037 A1	19-10-2017	BR 112018067753 A2 CN 109690871 A EP 3387706 A1 WO 2017178037 A1	15-01-2019 26-04-2019 17-10-2018 19-10-2017

REFERENCES CITED IN THE DESCRIPTION

This list of references cited by the applicant is for the reader's convenience only. It does not form part of the European patent document. Even though great care has been taken in compiling the references, errors or omissions cannot be excluded and the EPO disclaims all liability in this regard.

Patent documents cited in the description

- CN 202010061865 [0001]
- CN 202010168550X [0001]
- US 7688271 B [0090] [0091]