



- (51) International Patent Classification:
H04B 10/27 (2013.01) H04B 10/61 (2013.01)
H04B 10/548 (2013.01)
- (21) International Application Number:
PCT/EP2022/056019
- (22) International Filing Date:
09 March 2022 (09.03.2022)
- (25) Filing Language: English
- (26) Publication Language: English
- (30) Priority Data:
2104000.1 23 March 2021 (23.03.2021) GB
- (71) Applicant: **BRITISH TELECOMMUNICATIONS PUBLIC LIMITED COMPANY** [GB/GB]; 1 Braham Street, London E1 8EE (GB).
- (72) Inventor: **MENCHETTI, Marco**; 9th Floor, One Braham, Braham Street, London E1 8EE (GB).
- (74) Agent: **BRITISH TELECOMMUNICATIONS PUBLIC LIMITED COMPANY, INTELLECTUAL PROP-**

ERTY DEPARTMENT; 9th Floor, One Braham, Braham Street, London E1 8EE (GB).

(81) Designated States (unless otherwise indicated, for every kind of national protection available): AE, AG, AL, AM, AO, AT, AU, AZ, BA, BB, BG, BH, BN, BR, BW, BY, BZ, CA, CH, CL, CN, CO, CR, CU, CZ, DE, DJ, DK, DM, DO, DZ, EC, EE, EG, ES, FI, GB, GD, GE, GH, GM, GT, HN, HR, HU, ID, IL, IN, IR, IS, IT, JM, JO, JP, KE, KG, KH, KN, KP, KR, KW, KZ, LA, LC, LK, LR, LS, LU, LY, MA, MD, ME, MG, MK, MN, MW, MX, MY, MZ, NA, NG, NI, NO, NZ, OM, PA, PE, PG, PH, PL, PT, QA, RO, RS, RU, RW, SA, SC, SD, SE, SG, SK, SL, ST, SV, SY, TH, TJ, TM, TN, TR, TT, TZ, UA, UG, US, UZ, VC, VN, WS, ZA, ZM, ZW.

(84) Designated States (unless otherwise indicated, for every kind of regional protection available): ARIPO (BW, GH, GM, KE, LR, LS, MW, MZ, NA, RW, SD, SL, ST, SZ, TZ, UG, ZM, ZW), Eurasian (AM, AZ, BY, KG, KZ, RU, TJ, TM), European (AL, AT, BE, BG, CH, CY, CZ, DE, DK, EE, ES, FI, FR, GB, GR, HR, HU, IE, IS, IT, LT, LU, LV, MC, MK, MT, NL, NO, PL, PT, RO, RS, SE, SI, SK, SM,

(54) Title: IMPROVEMENTS TO NETWORK SYNCHRONISATION

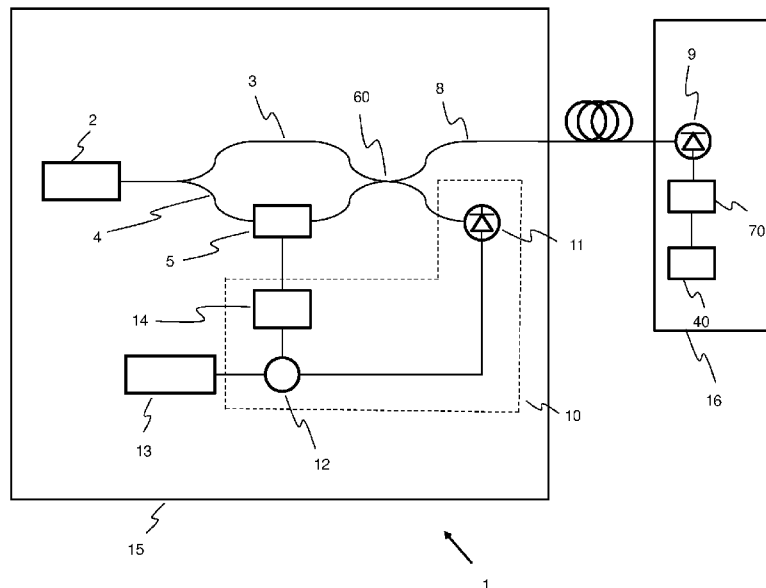

Figure 2

(57) Abstract: There is herein provided a method of controlling the frequency of operation of a component of a telecommunications network, the method comprising combining a first signal and a second signal to form a heterodyne signal, transmitting the heterodyne signal from a first node of the telecommunications network, detecting the transmitted heterodyne signal at a second node of the telecommunications network, controlling a frequency of operation of a component of the telecommunications network using a frequency of the detected heterodyne signal.



TR), OAPI (BF, BJ, CF, CG, CI, CM, GA, GN, GQ, GW,
KM, ML, MR, NE, SN, TD, TG).

Published:

— *with international search report (Art. 21(3))*

Improvements to Network Synchronisation

5 It is desirable to synchronise the various components within a telecommunications network in order to improve the efficiency of the network. For example, it is desirable to synchronise the frequency of operation of the local oscillators present in each of the network's nodes. It is also desirable to synchronise the phase of the local oscillators, such that each oscillator starts from the same value. The present invention concerns synchronisation of frequency of operation.

10 Known methods for synchronising the frequency of operation include intensity modulation. In particular, a continuous wave laser signal is modulated at the desired frequency of operation of the local oscillator of a node. The laser signal is transmitted from the network exchange to the node where it is detected at a photodetector, which converts it to an electrical signal and applies that electrical signal to the local oscillator
15 of the node.

It would be desirable to have alternative frequency synchronisation methods.

20 The present invention addresses some or all of the above-mentioned and/or other disadvantages associated with the prior art.

According to a first aspect of the invention there is provided a method of controlling the frequency of operation of a component of a telecommunications network, the method comprising:

25 Combining a first signal and a second signal to form a heterodyne signal;
Transmitting the heterodyne signal from a first node of the telecommunications network;
Detecting the transmitted heterodyne signal at a second node of the telecommunications network;
Controlling a frequency of operation of a component of the telecommunications network
30 using a frequency of the detected heterodyne signal.

Embodiments of the invention enable network components, such as local oscillators, to be synchronised more accurately than in known methods. In known methods, such as intensity modulation, the synchronisation signal is intensity modulated with the desired
35 operative frequency of the local oscillator. This synchronisation signal is transmitted

from the network exchange to a node in the network. The received signal is often noisy, which reduces accuracy. The present invention enables the operative frequency to be carried as the beat frequency of a heterodyne signal. Heterodyne signals are formed of two signals and both suffer noise. The frequency difference between them, i.e. the beat
5 frequency, is largely unaffected by noise. The resulting technique therefore provides more accurate synchronisation.

The first signal and/or the second signal may be optical signals and may be laser signals and may be transmitted over an optical fibre. The first node may be the network
10 exchange. The first node may be located remotely from the second node. The method may be a method for synchronising the local oscillator to a reference frequency for the network. The frequency of the first signal and/or the second signal may be from 100THz to 400THz. The frequency of the heterodyne signal may be the difference between the frequency of the first signal and the frequency of the second signal and may be from
15 5MHz to 100MHz and may be from 30MHz to 50MHz and may be approximately 40MHz.

The second node may be located at a street cabinet within the network. The step of detecting the heterodyne signal at the second node may be performed by a photodetector. The component of the telecommunications network may be a local
20 oscillator and may be a local oscillator of the node. The step of using a frequency of the detected heterodyne signal to control a frequency of operation of a component of the telecommunications network may comprise reducing the frequency of the detected heterodyne signal. This may be performed using a frequency divider or direct digital synthesis. The reduced frequency may be from 5MHz to 10MHz and is preferably
25 approximately 10MHz.

The method may further comprise controlling the frequency of the heterodyne signal. This may comprise modifying a frequency of the first signal prior to the step of combining
30 the first signal and the second signal. This may be performed by a modulator which may be an acousto-optic modulator and may be a free-space acousto-optic modulator.

The step of modifying a frequency of the heterodyne signal may comprise modifying a frequency of the first signal. This may take into account the frequency of the heterodyne
35 signal and may comprise measuring a frequency of the heterodyne signal. This step may further take into account a predetermined desired frequency of operation of the local

oscillator. The method may further comprise monitoring a frequency of the heterodyne signal.

5 The first signal and the second signal may be produced by splitting the output of a single laser source. In alternative embodiments the first and second signals may be produced by two separate laser sources. In these embodiments the step of modifying a frequency of the first signal or the second signal may comprise modifying the frequency of one of the laser sources.

10 According to a second aspect of the invention there is provided a system for controlling the frequency of operation of a component of a telecommunications network, the system comprising:

A combiner adapted to combine a first signal and a second signal to form a heterodyne signal;

15 A transmitter adapted to transmit the heterodyne signal from a first node of the telecommunications network;

A detector adapted to detect the transmitted heterodyne signal at a second node of the telecommunications network;

20 A controller adapted to control a frequency of operation of a component of the telecommunications network using a frequency of the detected heterodyne signal.

An embodiment of the invention will now be described in detail, for illustration only, and with reference to the accompanying drawings, in which:

25 Fig. 1 is a schematic view of a system in accordance with a first embodiment of the invention;

Fig 2 a schematic view of a system in accordance with a variation of the first embodiment of the invention;

30

Fig 3 a schematic view of a system in accordance with a second embodiment of the invention;

35 Fig 4 is a schematic view of a system in accordance with a third embodiment of the invention.

The arrangement in accordance with the invention is shown generally at 1 of Fig 1. In particular 15 represents a telecomms network exchange. At the exchange is a laser 2. The laser emits a continuous wave signal at 1550nm onto an optical fibre. A 1 x 2 optical splitter 30 splits the signal into two branches 3 and 4. Branch 4 carries the signal to acousto-optic modulator 5 which receives an input signal from frequency reference 13.

The acousto-optic modulator 5 causes the frequency of the continuous wave laser signal from exchange 15 to increase by an amount equal to the frequency of the input signal from the frequency reference 13. The frequency of the input signal is approx 40MHz. The two branches 3 and 4 then combine at a 2 x 1 optical splitter 7 and pass to photodetector 9 located at node 16. In this case the node 16 is a street cabinet. The photodetector 9 detects the laser signal. The act of combining the signals on the two branches 3 and 4 causes two heterodynes to be created. Referring the frequency of the signal on branch 3 as f_3 and the frequency of the signal on branch 4 to be f_4 , the two heterodynes have the frequency $f_3 + f_4$ and $f_3 - f_4$ respectively. The frequency $f_3 + f_4$ is approximately 400THz. This is outside the sensitivity range of photodetector 9. The frequency $f_3 - f_4$ has the frequency of approximately 40MHz which is within the sensitivity range of photodetector 9. It is therefore the $f_3 - f_4$ heterodyne which is detected. The detected signal is converted into an electrical signal by photodetector 9 and the electrical signal is passed through a frequency divider 70 which reduces the frequency of the signal from approx 40MHz to approx 10MHz. The 10MHz signal is then input to the local oscillator 40. The local oscillator 40 uses this frequency as its frequency of operation.

I turn now to Fig 2, in which like elements have the same reference number as in Fig 1. It may be that the frequency detected at photodetector 9 differs from that input to acousto-optic modulator 5. This is exacerbated by noisy environments. To address this, a frequency stabilisation feedback circuit is provided. This generally comprises the components shown within the dotted area 10 in Fig 2. In this embodiment, the 2 x 1 splitter 7 is replaced by a 2 x 2 splitter 60. As well as outputting the heterodynes to the photodetector 9, the splitter 60 also outputs the heterodynes to photodetector 11 within the exchange 15. Photodetector 11 has a similar range of sensitivity to photodetector 9 and so detects the $f_3 - f_4$ heterodyne but not the $f_3 + f_4$ heterodyne. Photodetector 11 converts the optical signal to an electrical signal and provides it to mixer 12, which also receives an input from the frequency reference 13. The mixer 12 outputs a signal to

voltage-controlled oscillator (VCO) 14. VCO 14 modifies the signal it applies to acousto-optic modulator 5 with the aim of bringing the frequency of the signal detected by photodetector 11 as close as possible to the desired frequency for transmission to node 16. Thus a feedback circuit is provided to stabilise the signal output by the exchange 15 to node 16.

Fig 3 shows a further embodiment of the invention in which like elements with Fig 2 have the same reference numeral + 100. In particular a continuous wave laser signal with a frequency of F is output from laser 102 at node 115. The signal passes to a free-space acousto-optic modulator 105 (free-space AOM). The free-space AOM 105 also receives an input signal (with a frequency of f) originating from frequency reference 113. This frequency f is approx 40MHz. The free-space AOM 105 outputs multiple laser signals into free space in different directions. In particular, it outputs a 0th order signal, a 1st order signal, a 2nd order signal and so-on. The 0th order signal has the same frequency as the signal the AOM 105 receives from the laser 102 (i.e. F). The frequency of the 1st order signal is that of the frequency of the laser 102 plus the frequency f of the signal the AOM 105 receives from the frequency reference 113 (i.e. $F+f$). The frequency of the 2nd order signal is that of the frequency of the laser 102 (F) plus twice the frequency ($2f$) of the signal the AOM 105 receives from the frequency reference 113 (i.e. $F+2f$). It is the 0th order and 1st order signals only that are of interest here.

The 0th order signal is directed to 50:50 beam splitter 118, which redirects a portion of it to photodetector 111 and allows a portion to pass through, towards node 116. The 1st order signal is directed to mirror 117 which reflects it to the beam splitter 118. A portion of the 1st order signal passes through the beam splitter 118 to photodetector 111 and a portion is diverted towards node 116.

The portion of the 0th order signal that passes through the beam splitter 118 combines with the portion of the first order signal that has been redirected by beam splitter 118 towards the node 116. These two signals combine to form two heterodynes with frequencies $2F+f$ and f . The two heterodynes are injected into an optical fibre which carries them to the photodetector 109 of node 116. The sensitivity range of the photodetector 109 is such that it is capable of detecting f but not $2F+f$. The detected signal is converted to an electrical signal of frequency f , reduced in frequency by frequency divider 170 to 10MHz and then passed to the local oscillator 140. Thus local

oscillator 140 has been synchronised to frequency f , which is its desired operating frequency. The embodiment of Fig 3 therefore achieves the same purpose as the embodiments of Figs 1 and 2.

5 In addition, the portion of the first order signal that passes through beam splitter 118 combines with the portion of the 0th order signal that is redirected by the beam splitter 118 to form two heterodynes with frequencies $2F+f$ and f . The sensitivity range of the photodetector 111 is such that it is capable of detecting f but not $2F+f$. As f is the desired
10 frequency of the local oscillator 140, the components 111-114 operate as a frequency stabilisation feedback circuit, identical to that described in relation to Fig 2.

Fig 4 shows an alternative embodiment of the invention. This embodiment has two lasers 202 and 250, each of which output a continuous wave signal at approximately 1550nm, which I will refer to as f_1 and f_2 . The signals are provided to the inputs of a 2 x
15 2 optical splitter 230. One of the splitter's output fibres carry the resulting heterodyne to a photodetector 209 connected to the local oscillator 240 of node 216. Similarly to previous embodiments, the photodetector detects the beat frequency f_1-f_2 , and applies that beat frequency to the local oscillator 240.

20 The other of the splitter's output fibres carries the heterodynes to photodetector 211 within the exchange 215. Photodetector 211 detects the beat frequency f_1-f_2 . Photodetector 211 converts the optical signal to an electrical signal and provides it to mixer 212, which also receives an input from the frequency reference 213. The input from frequency reference 213 is at the desired frequency of operation of the local
25 oscillator 240 in node 216. The mixer 212 outputs a signal to a Proportional-Integral-Derivative Controller (PID) 251. PID 251 uses the feedback this contains from the photodetector 211 to drive the laser 202 and keep it at the frequency of the frequency reference 213. This ensures that the beat frequency detected by the photodetector 209 is at the desired frequency of operation of the local oscillator 240.

30

Claims

1. A method of controlling the frequency of operation of a component of a telecommunications network, the method comprising:

- 5 Combining a first signal and a second signal to form a heterodyne signal;
Transmitting the heterodyne signal from a first node of the telecommunications network;
Detecting the transmitted heterodyne signal at a second node of the telecommunications network;
Controlling a frequency of operation of a component of the telecommunications network
10 using a frequency of the detected heterodyne signal.

2. A method as claimed in claim 1, wherein the first signal and the second signal are laser signals.

- 15 3. A method as claimed in claim 1 or claim 2, wherein the first node is located remotely from the second node.

4. A method as claimed in any preceding claim, wherein the component of the telecommunications network is a local oscillator of the second node.

- 20 5. A method as claimed in any preceding claim, the method further comprising controlling a beat frequency of the heterodyne signal.

- 25 6. A method as claimed in claim 5, wherein controlling a beat frequency of the heterodyne signal comprises modifying a frequency of the first signal prior to combining the first signal and the second signal.

7. A method as claimed in claim 6, wherein the step of modifying a frequency of the first signal is performed by a modulator which may be an acousto-optic modulator.

- 30 8. A method as claimed in any of claims 5 to 7, wherein the method further comprises measuring the beat frequency of the heterodyne signal and using the measured beat frequency to control the beat frequency of the heterodyne signal.

9. A system for controlling the frequency of operation of a component of a telecommunications network, the system comprising:

A combiner adapted to combine a first signal and a second signal to form a heterodyne signal;

5 A transmitter adapted to transmit the heterodyne signal from a first node of the telecommunications network;

A detector adapted to detect the transmitted heterodyne signal at a second node of the telecommunications network;

10 A controller adapted to control a frequency of operation of a component of the telecommunications network using a frequency of the detected heterodyne signal.

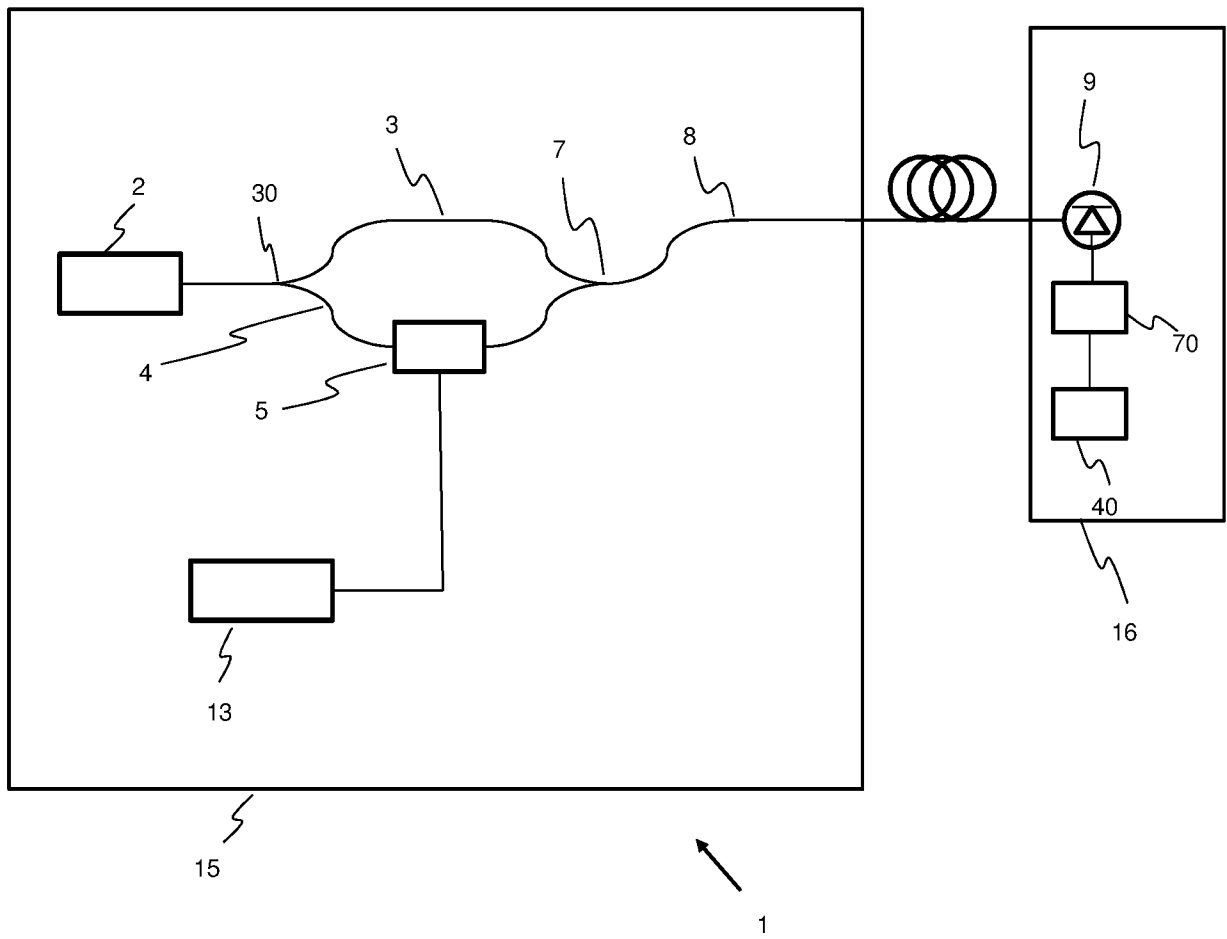

Figure 1

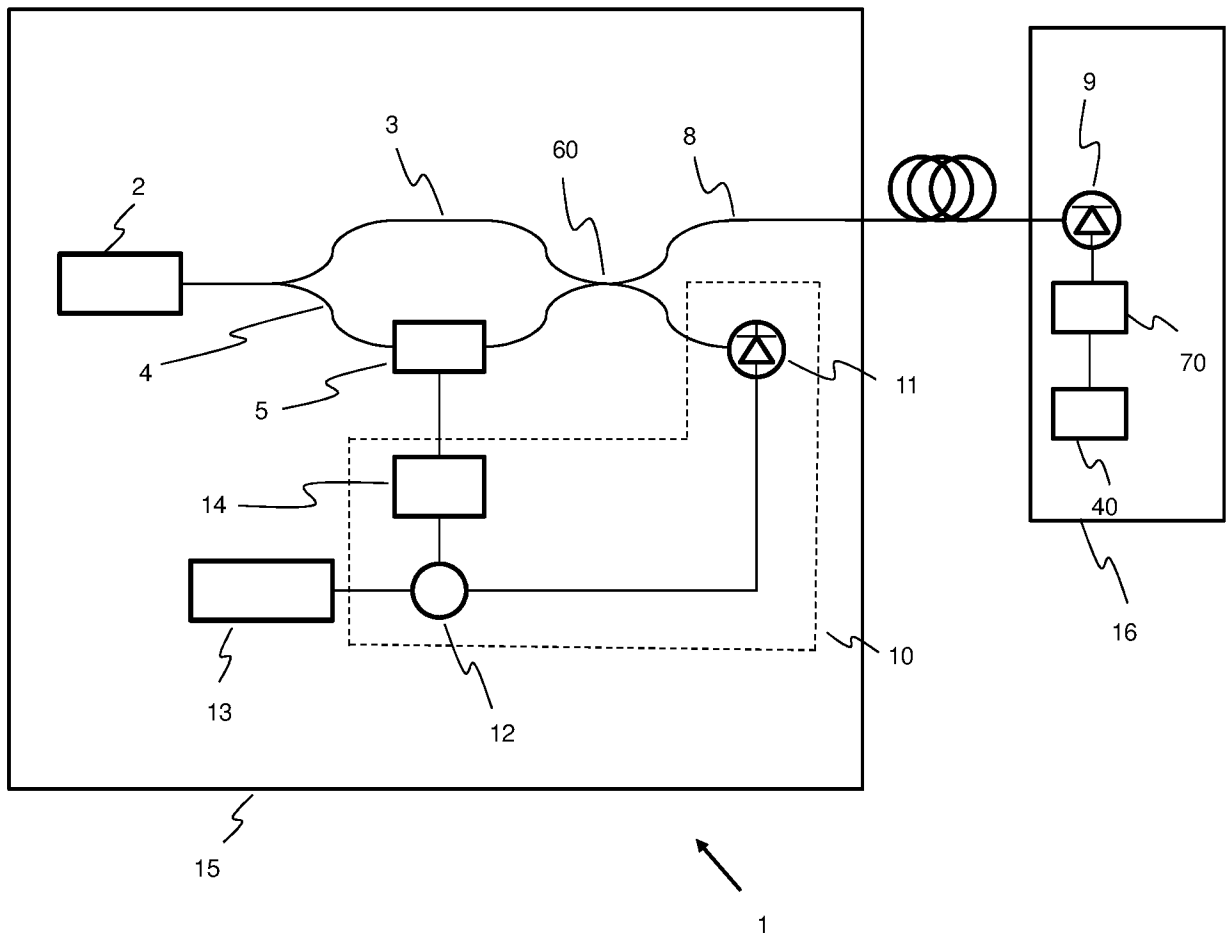

Figure 2

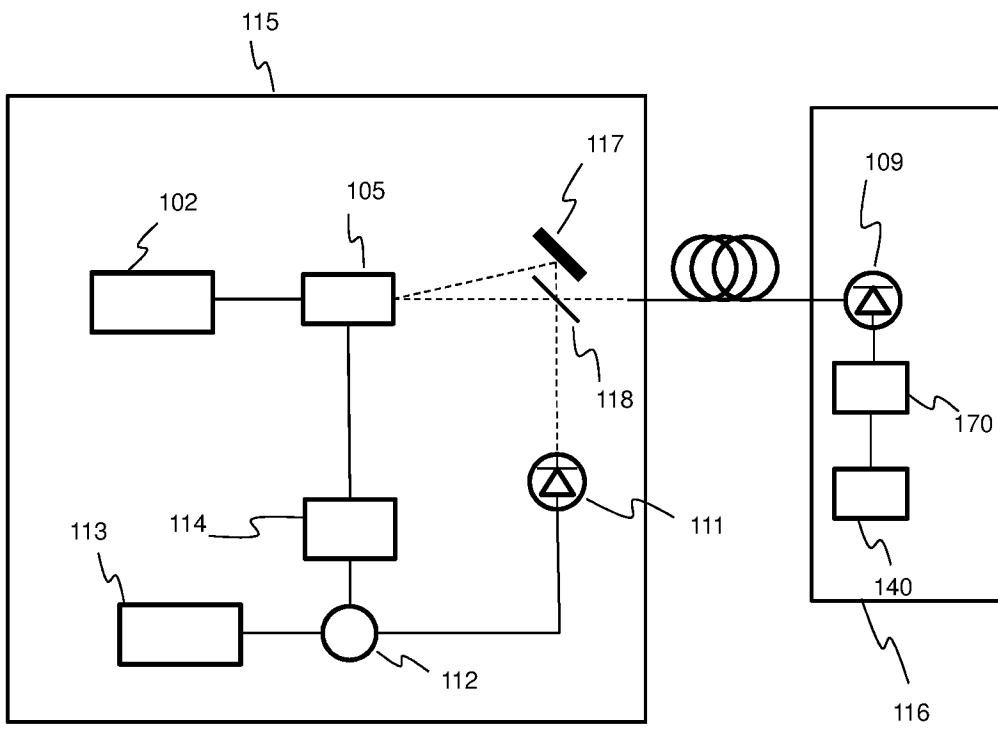

Figure 3

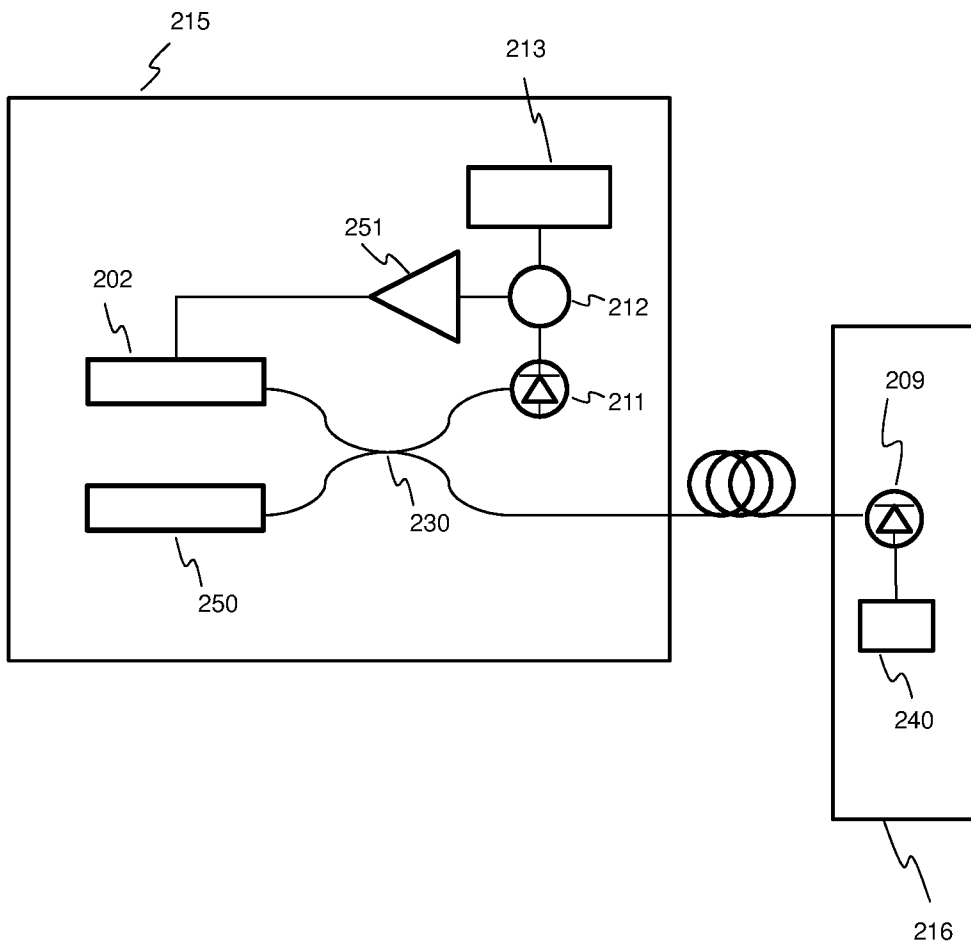

Figure 4

INTERNATIONAL SEARCH REPORT

International application No
PCT/EP2022/056019

A. CLASSIFICATION OF SUBJECT MATTER
INV. H04B10/27 H04B10/548 H04B10/61
ADD.

According to International Patent Classification (IPC) or to both national classification and IPC

B. FIELDS SEARCHED
 Minimum documentation searched (classification system followed by classification symbols)
H04B

Documentation searched other than minimum documentation to the extent that such documents are included in the fields searched

Electronic data base consulted during the international search (name of data base and, where practicable, search terms used)
EPO-Internal

C. DOCUMENTS CONSIDERED TO BE RELEVANT

Category*	Citation of document, with indication, where appropriate, of the relevant passages	Relevant to claim No.
X	US 5 896 211 A (WATANABE SHIGEKI [JP]) 20 April 1999 (1999-04-20) figure 21 column 2, line 6 - line 14 -----	1-9
X	US 2009/047023 A1 (PESCOD CHRISTOPHER RALPH [GB] ET AL) 19 February 2009 (2009-02-19) figures 1, 3 paragraphs [0035], [0055], [0056], [0060], [0061], [0069], [0070] -----	1-9
A	JP H03 24829 A (FRANCE ETAT) 1 February 1991 (1991-02-01) figure 1 column 1 - column 3 -----	7

Further documents are listed in the continuation of Box C.

See patent family annex.

* Special categories of cited documents :

- "A" document defining the general state of the art which is not considered to be of particular relevance
- "E" earlier application or patent but published on or after the international filing date
- "L" document which may throw doubts on priority claim(s) or which is cited to establish the publication date of another citation or other special reason (as specified)
- "O" document referring to an oral disclosure, use, exhibition or other means
- "P" document published prior to the international filing date but later than the priority date claimed

- "T" later document published after the international filing date or priority date and not in conflict with the application but cited to understand the principle or theory underlying the invention
- "X" document of particular relevance; the claimed invention cannot be considered novel or cannot be considered to involve an inventive step when the document is taken alone
- "Y" document of particular relevance; the claimed invention cannot be considered to involve an inventive step when the document is combined with one or more other such documents, such combination being obvious to a person skilled in the art
- "&" document member of the same patent family

Date of the actual completion of the international search
30 May 2022

Date of mailing of the international search report
13/06/2022

Name and mailing address of the ISA/
 European Patent Office, P.B. 5818 Patentlaan 2
 NL - 2280 HV Rijswijk
 Tel. (+31-70) 340-2040,
 Fax: (+31-70) 340-3016

Authorized officer
Ganzmann, Anna

INTERNATIONAL SEARCH REPORT

Information on patent family members

International application No

PCT/EP2022/056019

Patent document cited in search report	Publication date	Patent family member(s)	Publication date	
US 5896211	A	20-04-1999	CA 2051325 A1	15-03-1992
			EP 0477699 A2	01-04-1992
			EP 0772312 A2	07-05-1997
			EP 0772313 A2	07-05-1997
			EP 0772314 A2	07-05-1997
			US 5896211 A	20-04-1999

US 2009047023	A1	19-02-2009	AU 2005303660 A1	18-05-2006
			EP 1815618 A1	08-08-2007
			ES 2395036 T3	07-02-2013
			JP 4723575 B2	13-07-2011
			JP 2008507862 A	13-03-2008
			US 2009047023 A1	19-02-2009
			WO 2006051262 A1	18-05-2006

JP H0324829	A	01-02-1991	CA 2018095 A1	02-12-1990
			DE 69015259 T2	06-07-1995
			EP 0401126 A1	05-12-1990
			FR 2647987 A1	07-12-1990
			JP H0324829 A	01-02-1991
