

(19)
(12)

(KR)
(A)

(51) 。 Int. Cl. ⁷
H02K 27/30

(11)
(43)

2002 - 0037537
2002 05 22

(21) 10 - 2000 - 0067496
(22) 2000 11 14

(71) 209 3 1/4

(72) 209 3 1/4

(74)

:

(54)

가

, ,

- 1 ,
- 2 ,
- 3 ,
- 4 ,
- 5 .

< >

- 100: 101:
- 102: 103:
- 104: 105:
- 110: 120:

,

.

가

가

,

가가

가

.

,

.

가

1

2

3

4

5

1
10)

(120)

(100)

(1

2 3, 4, 5

(100)

(105)

(103),
(102)

(103)

(104)가
(110)

(103)
(104)

(101)

(102),
(102)

2, 3, 4

(103)

(102)

가

(103)

(103)

(102)

5
(103)

(101)

(102)

가

가

(101)

가

(101)

(102)

가

(102)

(120)

가

(101)

(110)

가

가

(57)

1.

가

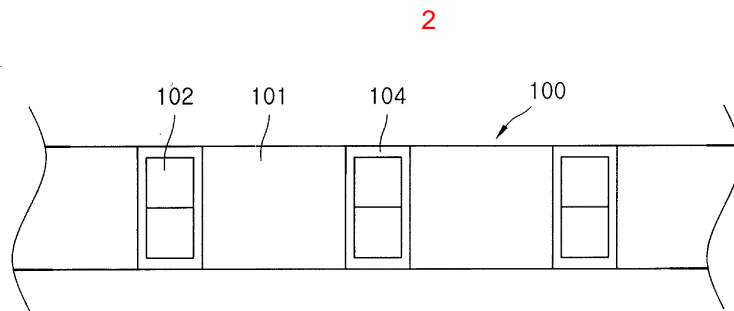
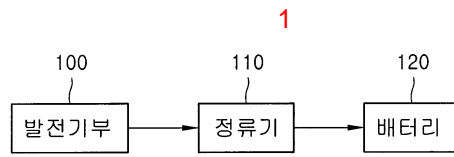

3

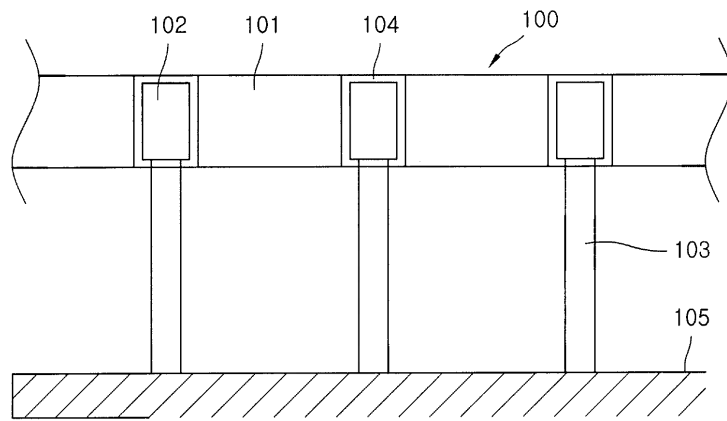

4

