

No. 843,185.

PATENTED FEB. 5, 1907.

P. R. THOM.

PROCESS FOR CLEANSING THE SCREENS OF PULP SCREENING MACHINES.

APPLICATION FILED OCT. 14, 1905.

2 SHEETS—SHEET 1.

Fig. 1.

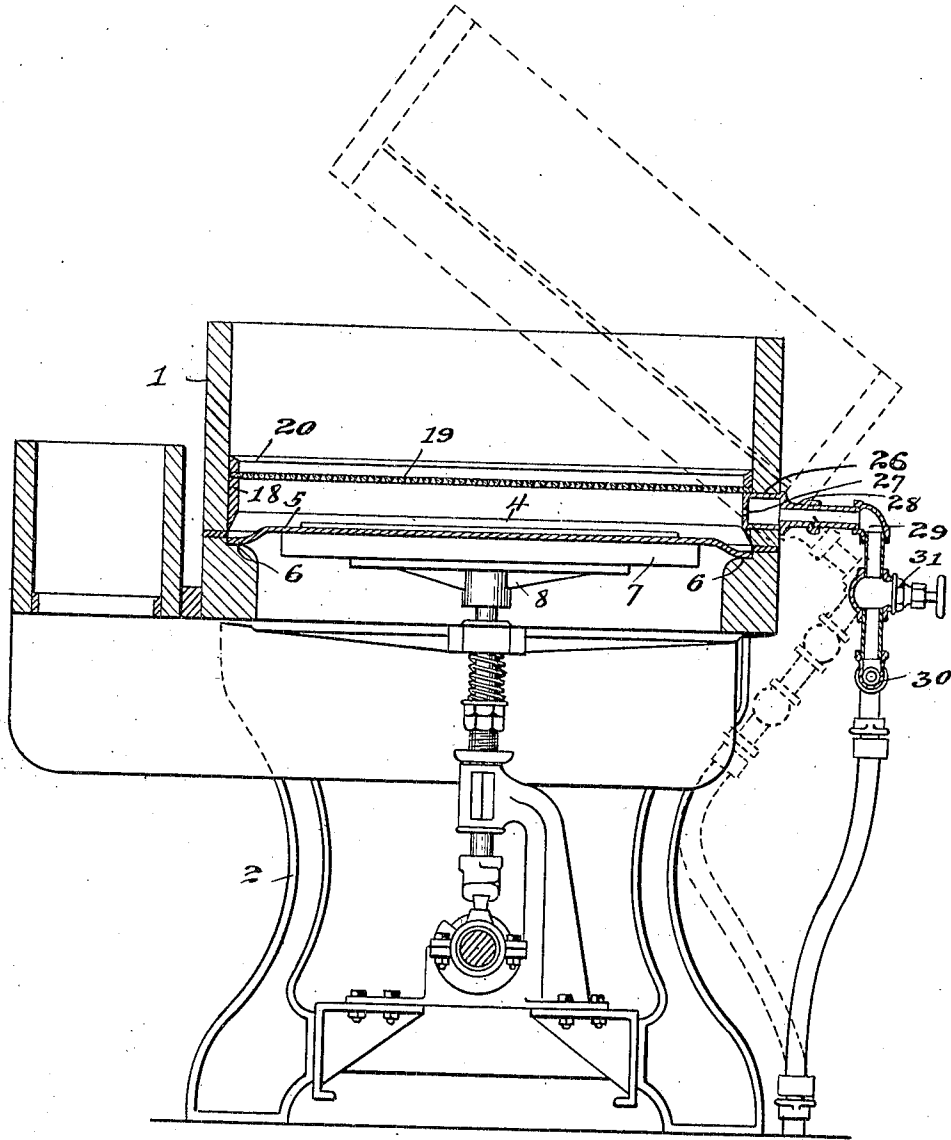

Fig. 2.



Witnesses,
F. Mann,
Water M. Fuller

Inventor,
Peter R. Thom
Bylfield, Towle & Linticum
Attys.

No. 843,185.

PATENTED FEB. 5, 1907.

P. R. THOM.

PROCESS FOR CLEANSING THE SCREENS OF PULP SCREENING MACHINES.

APPLICATION FILED OCT. 14, 1905.

2 SHEETS—SHEET 2.

Fig. 3.

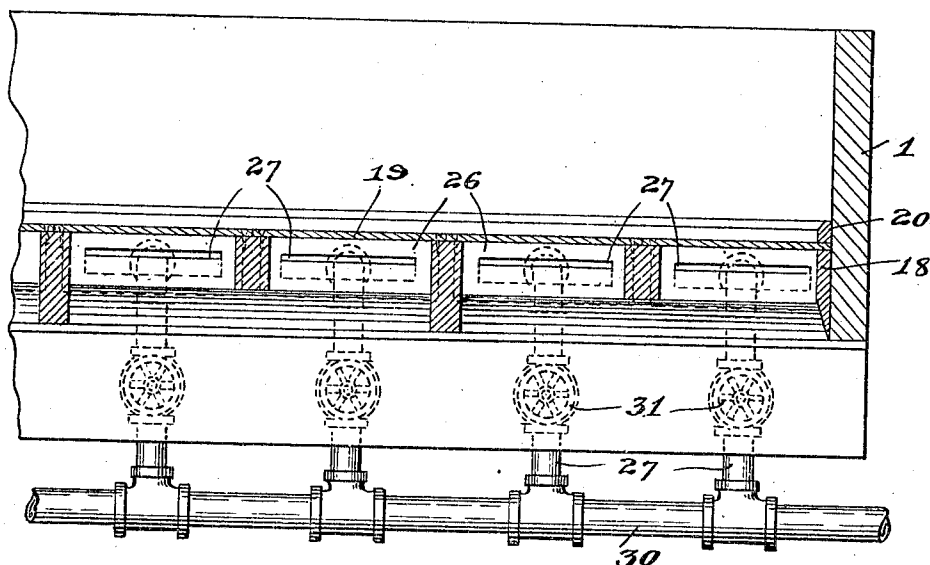

Witnesses,
E. D. Mann,
Walter M. Fuller

Inventor,
Peter R. Thom
By *Offield, Towle & Lenthicum*
Attys.

UNITED STATES PATENT OFFICE.

PETER R. THOM, OF APPLETON, WISCONSIN, ASSIGNOR OF TWO-THIRDS TO
KIMBERLY & CLARK COMPANY, OF NEENAH, WISCONSIN, A CORPORATION
OF WISCONSIN.

PROCESS FOR CLEANSING THE SCREENS OF PULP-SCREENING MACHINES.

No. 843,185.

Specification of Letters Patent.

Patented Feb. 5, 1907.

Application filed October 14, 1905. Serial No. 282,863.

To all whom it may concern:

Be it known that I, PETER R. THOM, a citizen of the United States, residing at Appleton, in the county of Outagamie and State of Wisconsin, have invented a certain new and useful Process of Cleansing the Screens of Pulp-Screening Machines, of which the following is a specification.

This invention relates to an improved process for cleansing the screens of pulp-screening machines; and the salient object of the invention is to provide a method whereby the screen-plates may be cleaned or freed from the accumulation of clots in the screen-openings practically without interrupting the operation of the machine and at the same time without detrimentally affecting the pulp mixture.

Machines of the character to which this invention is applicable comprise one or more vats the lower portion or portions of which contain horizontally-disposed screen-plates, through which the pulp in dilute form is caused to flow during the screening operation. These screen-plates as usually constructed are provided with long narrow slot-like openings or screen-passages which permit the fibrous pulp to pass through more or less readily yet insure against the passage of clots and coarse impurities. In the use of such machines the pulp is forced or drawn through the screen-plates by a pulsating movement of the liquid or dilute pulp, such movement being necessary to prevent the fibrous pulp from immediately lodging in the slots and preventing the flow therethrough. In spite of such pulsating movement it is found in practice that the fiber gradually lodges in the slots of the screen-plates, eventually forming clots or strings which depend through the screen-openings, and from time to time these clots break loose and pass on with the screened pulp. The clots therefore remain more or less intact when they reach the felt of the paper-mill and form blotches in the finished paper.

In order to obviate the formation of such blotches, it is the practice to cleanse the screen-plates from time to time, and this has usually been done by lifting up the upper part of the vat (within the lower edge of which the screen-plates are seated) and then

flushing or rinsing off the clots by directing a stream of water against the under sides of the screen-plates. In performing this operation more or less water usually flows into the pulp in the vat, thus diluting the same and rendering it uneven in consistency, which unevenness of course appears in the paper made therefrom. It has been proposed to effect this flushing off or rinsing out of the screen-plates by arranging a series of jet-pipes in the lower part of the vat just below the under surface of the screen-plates and from time to time forcing in water under pressure through these jet-pipes, thus washing off the clots and clearing the screen-openings. This method obviously involves seriously diluting the pulp besides requiring that the screening operation be temporarily arrested. Moreover, the presence of the jet-pipes in the lower part of the vat causes the pulp to lodge thereon and form accumulations of fiber, which from time to time are dislodged in the form of wads, which in turn produce blotches and unevenness in the paper.

I have discovered that by simply introducing fluid under a relatively high pressure to the substantially closed space in the lower part of the vat or vats beneath the screen-plates the fluid thus introduced in seeking to pass out through the screen-openings will effectually dislodge and drive back the clots depending therethrough and will effectually clear out the screen-openings, the pulp adhering to the screen-slots being chiefly forced upwardly into the upper part of the vat. By introducing a gaseous fluid, such as air, under sufficient pressure I obviously avoid any dilution of the pulp, and by using steam (which is sometimes more readily accessible than air) the amount of dilution caused by water of condensation is so slight as to be negligible in effect. In carrying out my improved method I preferably introduce a blast of steam or air through the side wall of the vat and in such manner that the blast is caused to sweep transversely across the under faces of the screen-plates; but nevertheless the fluid may be otherwise injected—as, for example, through an inlet in the bottom of the tank or through an inlet in the screen-plate, the presence of the screen-openings

being in itself sufficient to direct the flow of the fluid therethrough in such manner as to effectually clear these openings regardless of the direction in which the fluid enters the vat.

5 In any case it is essential that a sufficiently high pressure be employed to create a vigorous flow up through the screen-plates.

My improved process can be carried out in one specific manner in conjunction with the apparatus shown and described in the accom-
10 paning drawings, in which—

Figure 1 is a transverse sectional view of a screening-machine equipped with apparatus suitable for carrying into effect my improved
15 process. Fig. 2 is a sectional detail of a fragmentary portion of one of the screen-plates used in such machine and showing particularly the form of the slot-openings and the manner in which the clots accumulate there-
20 in. Fig. 3 is a sectional detail taken longitudinally through several of the vat-sections and looking toward that side of the vat through which the cleansing fluid is introduced.

25 Referring to said drawings, 1 designates as a whole a suitable vat or screen-box upon a supporting-frame, (designated as a whole 2,) said box being, as usual, of oblong rectangular form and provided with a plurality of
30 movable bottom sections 4, each connected with a vertically-reciprocatory plunger, whereby they are alternately raised and lowered a short distance to impart a pumping action to the liquid contained in the vat.
35 Describing one of such sections in detail, 5 designates a flexible sheet of impervious material secured at its margins to the bottom edges of the vat, as indicated at 6, and supported throughout its principal area by an
40 underlying plate 7, mounted upon the upper end of a plunger-head 8. During the rising movement of the plunger the liquid in the vat below the screens is lifted and tends to flow back through the screen-openings, while during
45 the descent of the plunger the movable bottom section exerts an exhaust action which tends to draw the liquid through the screen-plates, which are supported some distance above the bottom.

50 The screen-plates 19 are arranged horizontally in a plane intermediate the depth of the vat and are in the present instance made removable. To this end a lower box-like supporting-frame 18 is secured within the vat
55 with its lower edge coincident with the bottom thereof. Its upper edge serves to support said screen-plates. In order to hold the screen-plates in position, an overlying frame 20 is provided, which rests at its lower edge
60 directly upon the screen-plates and is detachably secured in this position, so that it may be removed when desired.

Each screen-plate, as best seen in detail, Fig. 2, is provided with a series of narrow parallel slot-like screen-openings 21, which are

downwardly flaring or of diverging walls as viewed in cross-section. These slots 21 are made of the requisite depth to suitably screen
70 the pulp, and inasmuch as such slots are necessarily comparatively narrow they tend to clog and become filled with accumulations of clots, as hereinbefore described.

Describing the injector mechanism, 26 designates a series of header-boxes conveniently mounted in the side wall of the vat laterally
75 opposite the space beneath the screen-plates and between the latter and removable bottom sections. As shown, there are two such header-boxes opposite each vat-section, the number of header-boxes corresponding to the
80 number of individual screen-plates. Each header-box extends through the side of the vat and is provided in its inner face with the slot 27, extending the full length of the box or the full depth of the screen-plate. The outer
85 side of each box is provided with a nipple 28, with which is connected a supply-pipe 29, and these supply-pipes 29 are in turn conveniently connected with a main header-pipe 30. Each supply-pipe is provided with a control-
90 ling-valve 31. The main header-pipe 30 connects through a pipe 32 with any suitable source of fluid under pressure.

In order that the screen-box or upper portion of the vat may be tilted up into the position indicated in dotted lines in Fig. 1 and expose the under side of the screen-plates, a section of the pipe 32 is made flexible.

In carrying out my process with the apparatus thus described fluid under pressure,
100 such as air or steam, is admitted to the several header-boxes 26 and from the latter flows into the lower vat-sections and escapes upwardly through the screen-plates. The fluid is admitted under such pressure as to expel or
105 displace the liquid on the under side of the screen-plates, and the fluid is admitted in such quantities as to cause it to flow through all of the openings of the screen-plates simultaneously. In thus circulating through the
110 space below the screen-plates the fluid sweeps the depending clots upwardly into the downwardly-diverging slot-openings and expels the fiber upwardly through the screen-openings. The cleansing of the screen is accom-
115 plished very promptly and without necessarily interrupting the operation of the machine, although the cleansing of the plates will of course momentarily arrest the flow of pulp therethrough. The provision of the separate
120 header-boxes and branch pipes 29, each controlled by an independent valve 31, enables the cleaning of the screens to be done progressively or one section at a time.

I claim as my invention—

1. The herein-described method of cleansing
125 screening screen-plates of pulp-screening machines in their operative position, which consists in subjecting the under sides of the plates to the action of a current of fluid delivered against
130

the plates at a relatively high pressure, much in excess of the hydrostatic pressure to which the plates are subject in normal use, and so confining said current of fluid that it is compelled to force its way through the screen-openings, thereby driving back the accumulations of pulp fiber and clearing said screen-openings.

2. The herein-described process of cleansing screen-plates of pulp-screening machines, which consists in subjecting the delivery sides of the plates to the action of a current of gaseous fluid delivered against the plates at a relatively high pressure, much in excess of the hydrostatic pressure to which the plates are subject in normal use, and so confining said current of fluid that it is compelled to force its way through the screen-openings and thereby drive back the accumulations of pulp fiber and thus clear said screen-openings.

3. The herein-described process of cleansing screen-plates of pulp-screening machines while in their operative position and while submerged in a bath of dilute pulp, which consists in subjecting the under sides of the plates to the action of a current of gaseous fluid delivered in proximity to the plates at a relatively high pressure, sufficiently in excess of the hydrostatic pressure to which the plates are then subject to expel and drive back the pulp liquid away from the under surface of the plates and so confining said current of fluid that it is compelled to force its way through the screen-openings and thereby effects the clearing of the screen-openings.

PETER R. THOM.

Witnesses:

E. L. CHRISTIAN,
H. G. HARMON.